



THE UNIVERSITY OF  
**WAIKATO**  
*Te Whare Wānanga o Waikato*

Research Commons

<http://researchcommons.waikato.ac.nz/>

## Research Commons at the University of Waikato

### Copyright Statement:

The digital copy of this thesis is protected by the Copyright Act 1994 (New Zealand).

The thesis may be consulted by you, provided you comply with the provisions of the Act and the following conditions of use:

- Any use you make of these documents or images must be for research or private study purposes only, and you may not make them available to any other person.
- Authors control the copyright of their thesis. You will recognise the author's right to be identified as the author of the thesis, and due acknowledgement will be made to the author where appropriate.
- You will obtain the author's permission before publishing any material from the thesis.

Phosphorus Distribution In Relation To Soil  
Landscape Groups In Steep North Island  
Hill-country In New Zealand

A thesis  
submitted in partial fulfilment  
of the requirements for the degree  
of  
**Master of Science in Earth and Ocean Science**  
at  
**The University of Waikato**  
By

**Max Arrowsmith**



THE UNIVERSITY OF  
**WAIKATO**  
*Tē Whare Wānanga o Waiāto*

2013



# *Abstract*

Phosphorus fertiliser is necessary to maintain the production of New Zealand hill country pastures. Technological advances in GIS and GPS have given aerial fertiliser applicators more precision than ever before. The key question is; to what extent do soil chemical properties vary within hill country landscapes, and is a knowledge of the variability able to be used to differentially apply fertiliser, maximise P fertiliser use efficiency, and minimise P loss to waterways? The objective of this thesis was to quantify the phosphorus variability on Blue Duck Station, a summer-moist hill-country farm located in the Central North Island of New Zealand. The soil comprised Allophanic Soil (Andisols) on the flat to low slopes with Brown Soil (Inceptisols) on the steeper hills.

Blue Duck Station was delineated into six soil-landscape groups (north facing medium slopes, north facing steep slopes, south facing steep slopes, south facing medium slopes, flat ridge tops, and flat valley floors, based on slope, aspect, and elevation using GIS. Three replicate units were randomly selected from each of the six soil-landscape groups, which gave 18 study-sites in total. For each study site, one transect sample and five grid samples were collected. Olsen P, Anion Storage Capacity, pH, Sulphate-sulphur and Cations (Mg, Na, K, Ca) were determined.

The Olsen P ranged from a mean of 6.8 in the south facing medium slopes to 21.2 in the north facing medium slopes. North facing medium slopes and valley low floors had higher mean Olsen P values than all other landscape groups ( $P < 0.01$ ) and also had the greatest variability in Olsen P values. The majority of Olsen P values were considered 'low' or 'very low'. Soil pH was consistent, ranging between 5 and 5.4, whilst anion storage capacity (ASC) levels ranged from 35% to 85%. High ASC levels indicated soils of volcanic origin, containing tephra, whereas low ASC levels were associated with soil predominantly derived from tertiary sedimentary rock.

At Blue Duck Station, the application of higher rates of P fertiliser to south facing steep slopes and south facing medium slopes, with medium rates of P fertiliser addition to north facing steep slopes and ridge low slopes would optimise fertiliser use. There is limited benefit in applying fertiliser to north medium slopes and flat valley floors as Olsen P is near optimal for this environment and stock transfer will continue to add nutrients to these areas.

The variability within a sample site (between grid and transect samples) was often greater than the range of variability the means across all the landscape groups. Due to such large sample variability, difficulties arise when attempting to recommend accurate fertiliser regime, or sampling programs. The soil analysis results from a small number of samples should be treated with caution.

The Best Management Practice for soil sampling the Central North Island Hill Country would be to avoid sampling small exceptional areas like flat valley floors and flat ridge tops. Focusing sample regimes on a number of transects across northern and southern slopes would give more representative results.



## Acknowledgements

Without doubt, my thesis wouldn't have been possible if not for the support and encouragement that Dr. Megan Balks and Dr. Doug Edmeades gave me, starting as supervisors, finishing as friends.

Mum, Dad, Charles, Annabel and Max, your combined mathematical talent, grammatical skill and unwavering support were exactly what I needed. Simon, Todd, Joel and Brad, my thanks go without saying.

The financial support provided to me by Whanganui River Enhancement Trust, New Zealand Fielday's scholarship, University of Waikato and Europhins Laboratory has meant that I was able to put everything I had into completing a fantastic thesis.

To the rest of the readers, all that we are is the result of what we have thought. The mind is everything. What we think we become.

*"All men dream: but not equally. Those who dream by night in the dusty recesses of their minds wake in the day to find that it was vanity: but the dreamers of the day are dangerous men, for they may act their dreams with open eyes, to make it possible. This I did".*

- T. E. Lawrence



# Table of Contents

<b>ACKNOWLEDGEMENTS</b>	<b>V</b>
<b>TABLE OF CONTENTS</b>	<b>VII</b>
<b>LIST OF FIGURES</b>	<b>XIII</b>
<b>LIST OF TABLES</b>	<b>XVII</b>

## **CHAPTER 1**

<b>INTRODUCTION</b>	<b>1</b>
<b>1.1 SOIL PHOSPHORUS IN NEW ZEALAND HILL-COUNTRY</b>	<b>1</b>
<b>1.2 POTENTIAL OF GIS AND GPS TO AID IN THE APPLICATION OF FERTILISER</b>	<b>2</b>
<b>1.3 LOCATION OF STUDY</b>	<b>3</b>
	<b>4</b>
<b>1.4 THESIS OBJECTIVE, HYPOTHESIS AND RESEARCH QUESTIONS</b>	<b>5</b>

## **CHAPTER 2**

<b>LITERATURE REVIEW</b>	<b>7</b>
<b>2.1 INTRODUCTION</b>	<b>7</b>
<b>2.2 SOIL PHOSPHORUS</b>	<b>7</b>
2.2.1 INTRODUCTION TO SOIL PHOSPHORUS	7
2.2.2 INORGANIC SOIL PHOSPHORUS	7
2.2.3 ORGANIC PHOSPHORUS	8
<b>2.3 PHOSPHORUS CYCLING</b>	<b>8</b>
2.3.1 BELOW-GROUND CYCLING	10
2.3.2 ABOVE GROUND P LOSSES	10
2.3.3 ANIMAL INTAKE	15
2.3.4 PHOSPHORUS RETURNS IN LITTER	15
2.3.5 PHOSPHORUS RETURNED IN DUNG	15



## *TABLE OF CONTENTS*

2.3.6	PLANT UPTAKE OF PHOSPHORUS	16
2.3.7	FERTILISER ADDITIONS	17
<b>2.4</b>	<b>PASTORAL PROPERTIES OF NEW ZEALAND HILL-COUNTRY FARMS</b>	<b>18</b>
2.4.1	INTRODUCTION TO PASTORAL PROPERTIES	18
2.4.2	VARYING PASTURE PRODUCTION DRIVEN BY SLOPE, ASPECT AND ALTITUDE	18
2.4.3	CLIMATIC INFLUENCES ON PASTURE PRODUCTION	19
2.4.4	MANAGEMENT OPTIONS FOR IMPROVED PASTURE PRODUCTION	20
2.4.5	PHOSPHORUS REQUIREMENTS FOR HILL-COUNTRY PASTURE	22
2.4.6	PASTURE COMPOSITION	22
<b>2.5</b>	<b>DIFFERENTIAL APPLICATION OF FERTILISER IN HILL-COUNTRY</b>	<b>22</b>
2.5.1	OVERSEER	23
2.5.2	FERTILISER MANAGEMENT USING GIS AND GPS	23
2.5.3	SOIL MAPPING AND ITS IMPLICATIONS FOR DIFFERENTIAL FERTILISER APPLICATION	26
<b>2.6</b>	<b>SOIL P MEASUREMENT METHODS</b>	<b>27</b>
2.6.1	INTRODUCTION	27
2.6.2	OLSEN P MEASUREMENT	27
2.6.3	PHOSPHORUS BUFFER CAPACITY	28
2.6.4	ANION STORAGE CAPACITY	29
<b>2.7</b>	<b>OTHER SOIL CHEMICAL PROPERTIES</b>	<b>30</b>
2.7.1	SOIL PH	30
2.7.2	CATION EXCHANGE CAPACITY	32
2.7.3	SULPHATE-SULPHUR	32
2.7.4	ORGANIC SULPHUR	32
2.7.5	CATIONS – MAGNESIUM, SODIUM, POTASSIUM AND CALCIUM	32
<b>2.8</b>	<b>ENVIRONMENTAL ISSUES RELATED TO FERTILISER USE</b>	<b>33</b>
<b>2.9</b>	<b>SUMMARY AND CONCLUSION</b>	<b>35</b>

**CHAPTER 3**

<b>PHYSICAL ENVIRONMENT, EXPERIMENTAL DESIGN, AND FIELD SAMPLING AND LABORATORY METHODS</b>	<b>37</b>
<b>3.1 INTRODUCTION</b>	<b>37</b>
<b>3.2 PHYSICAL ENVIRONMENT</b>	<b>37</b>
3.2.1 LOCATION	37
3.2.2 CLIMATE	37
3.2.3 PARENT MATERIAL	38
3.2.4 SOIL	39
3.2.5 LAND-USE CAPABILITY	39
<b>3.3 EXPERIMENTAL DESIGN</b>	<b>41</b>
3.3.1 EXPERIMENT OVERVIEW	41
<b>b) SLOPE</b>	<b>42</b>
<b>c) ASPECT</b>	<b>43</b>
<b>3.4 EXPERIMENTAL DESIGN</b>	<b>46</b>
3.4.1 SELECTING AND LOCATING STUDY SITES	46
3.4.2 TRANSECT LOCATION AND SAMPLE COLLECTION	47
3.4.3 SAMPLE LABELLING SYSTEM	49
<b>3.5 FIELD SAMPLING – NATIVE BUSH AREAS</b>	<b>50</b>
<b>3.6 LABORATORY METHODS</b>	<b>51</b>
3.6.1 INTRODUCTION	51
3.6.2 SAMPLE PREPARATION	51
<b>3.7 SOIL PH (METHOD UNDERTAKEN AND SUPPLIED BY EUROFINS LABS)</b>	<b>51</b>
3.7.1 REAGENT	51
3.7.2 STANDARDS	52
3.7.3 SAMPLE PREPARATION	52
3.7.4 ANALYSIS	52
<b>3.8 AMMONIUM ACETATE EXTRACTABLE CATIONS (METHOD UNDERTAKEN AND SUPPLIED BY EUROFINS LABS)</b>	<b>53</b>
3.8.1 APPARATUS	53
3.8.2 REAGENTS	53
3.8.3 STANDARDS	53
3.8.4 SAMPLE PREPARATION	55

## TABLE OF CONTENTS

3.8.5	ANALYSIS	55
3.8.6	DILUTIONS	55
3.8.7	CALCULATIONS	55
<b>3.9</b>	<b>OLSEN PHOSPHATE (METHOD UNDERTAKEN AND SUPPLIED BY EUROFINS LABS)</b>	<b>56</b>
3.9.1	APPARATUS	56
3.9.2	EXTRACTANT REAGENTS	56
3.9.3	FLOW INJECTION REAGENT	57
3.9.4	STANDARDS	58
3.9.5	SAMPLE PREPERATION	59
3.9.6	ANALYSIS	59
<b>3.10</b>	<b>POTASSIUM PHOSPHATE EXTRACTABLE SULPHATE SULPHUR (METHOD UNDERTAKEN AND SUPPLIED BY EUROFINS LABS)</b>	<b>60</b>
3.10.1	EXTRACTANT	60
3.10.2	SAMPLE PREPARATION	60
3.10.3	ANALYSIS USING ICS-2100 ION CHROMATOGRAPH	60
3.10.4	STANDARDS	60
3.10.5	INSTRUMENT QC STANDARDS	61
3.10.6	ANALYSIS	61
<b>3.11</b>	<b>POTASSIUM PHOSPHATE EXTRACTABLE ORGANIC SULPHUR (METHOD UNDERTAKEN AND SUPPLIED BY EUROFINS LABS)</b>	<b>62</b>
3.11.1	APPARATUS	62
3.11.2	EXTRACTION	62
3.11.3	STANDARDS	62
3.11.4	INSTRUMENT QC STANDARD	63
3.11.5	SAMPLE PREPARATION	63
3.11.6	ANALYSIS	64
<b>3.12</b>	<b>ANION STORAGE CAPACITY (METHOD UNDERTAKEN AND SUPPLIED BY EUROFINS LABS)</b>	<b>64</b>
3.12.1	APPARATUS	64
3.12.2	REAGENTS	64
3.12.3	STANDARDS	65
3.12.4	SAMPLE PREPARATION	65
3.12.5	ANALYSIS	66
<b>3.13</b>	<b>SOIL PH ANALYSIS AT WAIKATO UNIVERSITY</b>	<b>66</b>

**CHAPTER 4**

<b>RESULTS</b>	<b>67</b>
<b>4.1 SAMPLE SITE DESCRIPTION</b>	<b>67</b>
4.1.1 VALLEY LOW STUDY UNIT ONE	68
	<b>68</b>
4.1.2 VALLEY LOW STUDY UNIT TWO	69
4.1.3 VALLEY LOW STUDY UNIT THREE	70
4.1.4 RIDGE LOW STUDY UNIT ONE	71
4.1.5 RIDGE LOW STUDY UNIT TWO	72
4.1.6 RIDGE LOW STUDY UNIT THREE	73
4.1.7 NORTH FACING STEEP SLOPE STUDY UNIT ONE	74
4.1.8 NORTH FACING STEEP SLOPE STUDY UNIT TWO	75
4.1.9 NORTH FACING STEEP SLOPE STUDY UNIT THREE	76
4.1.10 NORTH MEDIUM STUDY UNIT ONE	77
4.1.11 NORTH MEDIUM STUDY UNIT TWO	78
4.1.12 NORTH MEDIUM STUDY UNIT 3	79
4.1.13 SOUTH STEEP STUDY UNIT ONE	80
4.1.14 SOUTH STEEP STUDY UNIT TWO	81
4.1.15 SOUTH STEEP STUDY UNIT THREE	82
4.1.16 SOUTH MEDIUM STUDY UNIT ONE	83
4.1.17 SOUTH MEDIUM STUDY UNIT TWO	84
4.1.18 SOUTH MEDIUM STUDY UNIT THREE	85
<b>4.2 INTRODUCTION OF SOIL CHEMICAL PROPERTY RESULTS</b>	<b>86</b>
4.2.1 RATINGS OF SOIL PROPERTIES	86
<b>4.3 RESULTS OF CHEMICAL ANALYSIS</b>	<b>87</b>
4.3.1 OLSEN P	87
4.3.2 ANION STORAGE CAPACITY	88
4.3.3 SOIL PH	89
4.3.4 ORGANIC SULPHUR	90
4.3.5 SULPHATE-SULPHUR	91
4.3.6 MAGNESIUM	92
4.3.7 POTASSIUM	93
4.3.8 CALCIUM	94

## *TABLE OF CONTENTS*

4.3.9 SODIUM	95
<b>4.4 BETWEEN SAMPLE VARIABILITY</b>	<b>96</b>
4.4.1 INTRODUCTION	96
4.4.2 OLSEN P	96
4.4.3 ANION STORAGE CAPACITY	97
4.4.4 PH	98
4.4.5 ORGANIC SULPHUR	99
4.4.6 SULPHATE-SULPHUR	100
4.4.7 MAGNESIUM	101
4.4.8 POTASSIUM	102
4.4.9 CALCIUM	103
4.4.10 SODIUM	104
4.4.11 BETWEEN VARIABLE RELATIONSHIPS	105
<b>CHAPTER 5</b>	
<b><i>DISCUSSION AND CONCLUSION</i></b>	<b>111</b>
<b>5.1. INTRODUCTION</b>	<b>111</b>
<b>5.2 VARIABILITY OF SOIL CHEMICAL PROPERTIES</b>	<b>112</b>
5.2.1 INTRODUCTION	112
5.2.2 SOURCE OF SOIL CHEMICAL VARIABILITY	112
<b>5.3 FERTILISER SCENARIOS AND RECOMMENDATIONS FOR BLUE DUCK STATION</b>	<b>118</b>
5.3.1 INTRODUCTION	118
5.3.2 VARYING SAMPLING, AND FERTILISER SCENARIOS	119
5.3.3 POTENTIAL FOR DIFFERENTIAL FERTILISER APPLICATION	122
<b>5.4 QUESTIONING TRADITIONAL SOIL SAMPLING METHODS</b>	<b>125</b>
<b>5.5 POTENTIAL FOR RUNOFF RECOMMENDATIONS</b>	<b>126</b>
<b>5.6 BLUE DUCK STATION AND BALLANTRAE HILL COUNTRY RESEARCH STATION COMPARISON</b>	<b>127</b>
<b>5.7 ADDRESSING THE RESEARCH HYPOTHESIS</b>	<b>127</b>
<b>5.8 RECOMMENDED FURTHER WORK</b>	<b>128</b>
<b>5.9 SUMMARY AND CONCLUSIONS</b>	<b>128</b>
<b><i>BIBLIOGRAPHY</i></b>	<b>131</b>
<b><i>APPENDIX</i></b>	<b>143</b>

## *List of Figures*

1.1: Location of the Blue Duck Station study area.....	4
2.1: Processes and interactions of the phosphorus cycle.....	9
1.2: Schematic of nutrient transfers in a grazed hill-country pasture.....	11
2.3: Varying soil phosphorus on hill country slopes.....	12
2.4: Schematic of nutrient transfer model in grazed hill country pasture.....	13
2.5: relationship between plant nutrient availability and soil pH.....	31
3.1: Digital elevation model of Blue Duck Station.....	41
3.2: Slope model of Blue Duck Station.....	42
3.3: Aspect model of Blue Duck Station .....	43
3.4: Landscape group model of Blue Duck Station .....	44
3.5: Slope model of Blue Duck Station.....	45
3.6: Sample layout of sampling pattern. Transect and grids .....	47
3.7: Summary of sample process.....	48
3.8: Example of labelling system for ridge low slope sample site 1.....	49
4.1: Valley low slopes replicate one.....	68
4.2: Valley low slopes replicate two .....	69
4.3: Valley low slopes replicate three .....	70
4.4: Ridge low slope replicate one.....	71
4.5: Ridge low slope replicate two .....	72
4.6: Ridge low slope replicate three .....	73
4.7: North facing steep slopes replicate one.....	74
4.8: North facing steep slopes replicate two.....	75
4.9: North facing steep slopes replicate three.....	76
4.10: North facing medium slopes replicate one.....	77

## *LIST OF FIGURES*

4.11: North facing medium slopes replicate two .....	78
4.12: North facing medium slopes replicate three.....	79
4.13: South facing steep slopes replicate one.....	80
4.14: South facing steep slopes replicate two.....	81
4.15: South facing steep slopes replicate three.....	82
4.16: South facing medium slopes replicate one .....	83
4.17: South facing medium slopes replicate two .....	84
4.18: South facing medium slopes replicate three... ..	85
4.19: The relationship between Olsen phosphorus ( $\mu\text{g}/\text{ml}$ ) and landscape groups.....	87
4.20: The relationship between anion storage capacity (%) and landscape groups.....	88
4.21: The relationship between soil pH and landscape groups.....	89
4.22: The relationship between organic sulphur (ppm) and landscape groups.....	90
4.23: The relationship between sulphate sulphur (ppm) and landscape groups.....	91
4.24: The relationship between Magnesium (Quick Test Value) and landscape groups...92	
4.25: The relationship between potassium (Quick Test Values) and landscape groups...93	
4.26: The relationship between calcium (Quick Test Value) and landscape groups.....94	
4.27: The relationship between sodium (Quick Test Values) and landscape groups.....95	
4.28: Variation of Olsen phosphorus within landscape units.....	96
4.29: Variation of anion storage capacity within landscape units.....	97
4.30: Variation of pH within landscape units.....	98
4.31: Variation of organic sulphur within landscape units.....	99
4.32: Variation of sulphate sulphur within units.....	100
4.33: Variation of magnesium within landscape units.....	101
4.34: Variation of potassium within landscape units.....	102
4.35: Variation of calcium within landscape units.....	103
4.36: Variation of sodium within landscape units.....	104

## *LIST OF FIGURES*

4.37: Scatter plot of anion storage capacity and calcium with a linear regression line to show the relationship.....	105
4.38: Scatter-plot of anion storage capacity and organic sulphur with a linear regression line to show the relationship.....	106
4.39: Scatter plot of anion storage capacity and magnesium with a linear regression line to show the relationship.....	107
4.40: Scatter plot of Olsen P and potassium with a linear regression line to show the relationship.....	108
4.41: Scatter plot of organic sulphur and sulphate sulphur with a linear regression line to show the relationship.....	109
4.42: Scatter plot of calcium and magnesium with a linear regression line to show the relationship.....	110
5.1: Soil profile showing the differences between sedimentary (calcium rich, low ASC) soils and volcanic (low calcium high ASC) .....	115
5.2: Relationship between economic optimal Olsen P and gross margin (\$/ha).....	119
5.3: Relationship between production and soil fertility, showing the economical optimal .....	121





## List of Tables

2.1: Average annual pasture production (kg DM/ha) on easy and steep slopes with increasing Olsen soil P for contrasting locations.....	21
2.2: The variation in fertiliser and application costs between targeted fertiliser application of varying soil p-retention levels compared with blanket fertiliser application of high P-retention soils (blanket high) or low P-retention soils (blanket-low) – hypothetical situation.....	25
2.3: Heavy metals and other potential toxic elements in rock phosphate, compared with averages in the earth’s crust.....	34
3.1: Summary of sample names.....	49
3.2: Stock standard amounts (ml).....	54
3.3: Cation concentration in standards, and the corresponding concentrations in the soil in Quick Test Units.....	54
3.4: Amounts of secondary standard needed to make up to volume.....	59
3.5: Amounts of secondary standards to be diluted with the extractant.....	61
3.6: Amounts of secondary standards to be diluted with the extractant.....	63
3.7: Working standard amounts.....	65
4.1: New Zealand Soil Bureau soil chemical properties ratings.....	86
5.1: Allophane test on selected landscape groups.....	113
5.2: Comparison between pastoral, primary forested vegetation and secondary re-growth forest vegetation sites.....	118
5.3: Fertiliser cost to raise current Olsen P level to optimal Olsen P level at Blue Duck Station, based on various sampling scenarios.....	120



# Chapter 1

## Introduction

### **1.1 *Soil phosphorus in New Zealand hill-country***

Phosphorus is a vital soil component. Soil phosphorus plays an essential role in plant health; promoting root growth and winter hardiness, stimulating tillering, and increased maturation speed. The aim of my study is to measure the variability of soil phosphorus, and other soil chemical properties, to determine whether precision agriculture methods could be applied to hill and steep land areas to maximise P fertiliser use efficiency.

Soil formation can be broken down into 5 soil forming factors. The 5 soil forming factors are; parent material, climate, organisms, relief and time (Jenny, 1941). Interactions between the soil forming factors influence the development and dynamic characteristics of soil. Parent material and topography are the two main factors that influence soil formation within hill-country farms. Steep slopes and varying aspects are encompassed by topography, which influence soil depth, P runoff, erosion potential, nutrient removal and climatic effects (Mclaren & Cameron, 1996, Gillingham, *et al.* 2003b). Parent material gives soils their inherent chemical and physical properties. Together, topography and parent material create a mosaic of soil types throughout the hill-country landscape.

Hill-country farms make up 3.5 million hectares of New Zealand's 14 million hectares of pastoral land (Williams & Haynes, 1990). Often considered the backbone of New Zealand pastoral farming, more sheep and cattle are bred and run on hill-country than on any other class of farmland in New Zealand. Due to the poor soil fertility of most hill-country farms, fertiliser addition is an essential component of pasture production. Fertiliser is used to supply soils with the

essential elements that are not immediately available in unfertilised soils (Binoka, 2008). The main addition to hill-country pasture is superphosphate, which helps to resolve soil fertility and mineral-deficiency problems. Superphosphate increases inorganic phosphorus and sulphur, leading to increased nitrogen fixation rates, as a result of increased clover growth (Williams & Haynes, 1990).

The addition of fertilisers to farming systems can have inadvertent environmental impacts. The main issue of phosphorus fertiliser application is the potential degradation caused to natural waterways. Due to natural phosphorus levels in aquatic systems being very low, small increases in the amount of phosphorus going into waterways can have a big effect. Phosphorus in the waterways encourages nuisance weed and algae growth, which, as the excess growth dies and decomposes, may impact stream life by starving the water of oxygen, advancing eutrophication.

## ***1.2 Potential of GIS and GPS to aid in the application of fertiliser***

My project investigates the potential of targeted phosphorus fertiliser application in hill-country. Global positioning systems (GPS) and global information systems (GIS) have reached a level of development and accessibility that allows them to be used for precision fertiliser application. In the past, the capability of fertiliser applicators to avoid application on specific areas was limited, however, the use of GIS and GPS has allowed for small areas like stock camps, streams and high fertility areas to be avoided.

Improved versatility and accuracy of fertiliser application, has come as a result of the combination of GPS and GIS systems. The GPS system allows the deliberate variation of application rates to meet the differences in optimum fertiliser requirements of contrasting landscape groups.

### **1.3 *Location of study***

My study was undertaken in the King Country, which is situated in the central North Island of New Zealand. My study area, Blue Duck Station, is a summer-moist hill-country farm located at Whakahoro, 43km south west of Taumarunui (Figure 1.1). The total area of Blue Duck station is 664 ha, 262 ha of pasture, and the remaining 402 ha made up of scrub and indigenous forest. The pasture is divided into 33 ha of strongly rolling easy hill-country, 76 ha of moderate hill-country, and the remaining 154 ha is moderate to steep hill-country, with exposed rock cliffs and steep gorges (Grant & Dudin, 2007). Blue Duck station has an effective farmed area of 425 ha, stocked with 3,978 stock units at a rate of 9.4 su/ha (Grant & Dudin, 2007).

Blue Duck Station is found in the Kaiwhakauka Catchment, a sub-catchment to the wider Whanganui River Catchment. Within the Kaiwhakauka Catchment, four percent of Whio (New Zealand's native Blue Duck) breeding pairs are found. Understanding soil phosphorus, is essential for the water quality of the Whanganui River and thus the protection of the Whio's habitat.

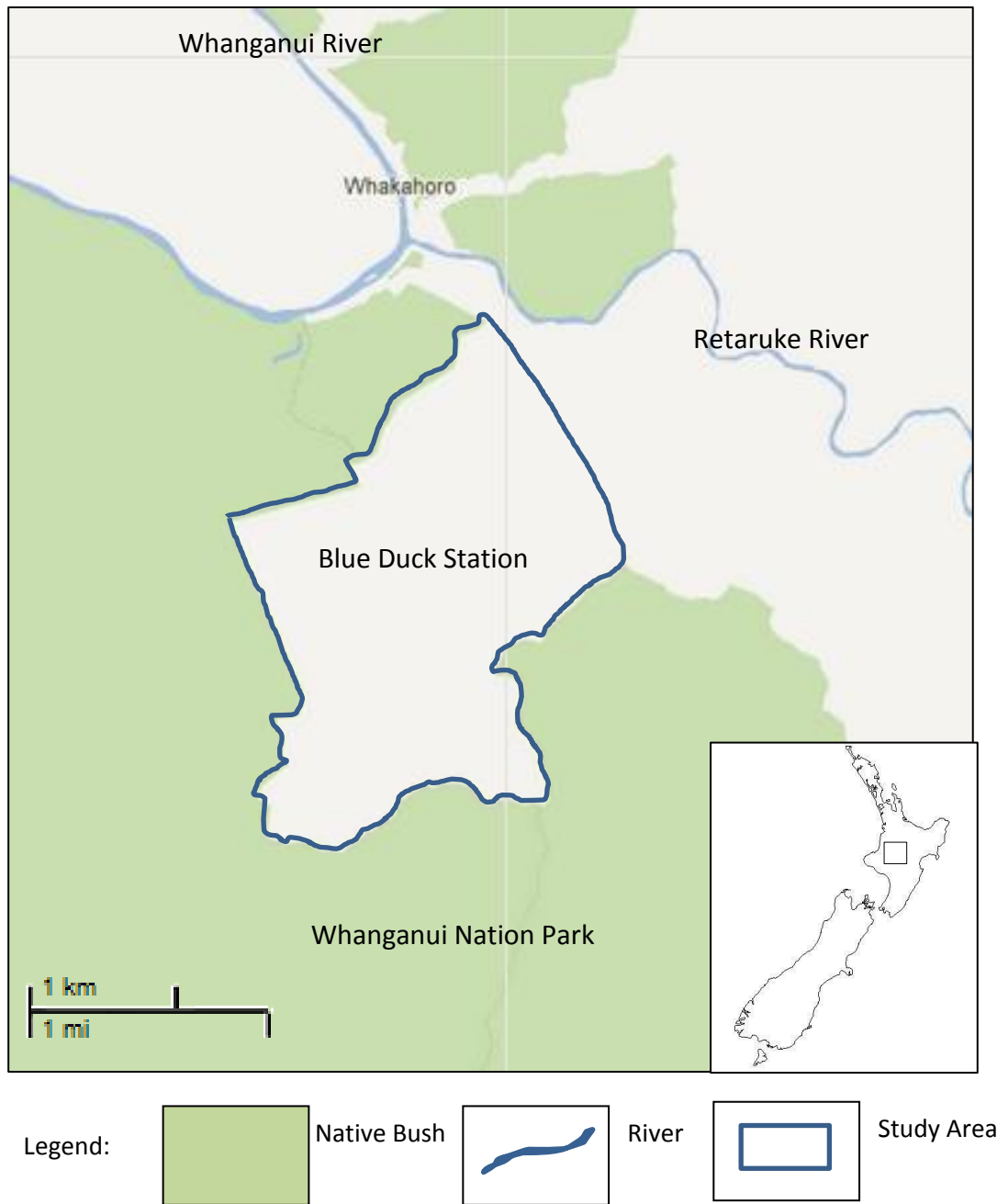

**Figures 1.1** Location of the Blue Duck Station study area

## **1.4 Thesis objective, hypothesis and research questions**

The overall objective of my study is to measure the variability of soil P and other soil chemical properties to determine whether precision agriculture methods could be applied to hill and steep land areas to maximise P fertiliser use efficiency both economically and environmentally.

The specific objectives of my study are to:

- Generate soil landscape groups for Blue Duck Station using available GIS information
- Create a robust sampling regime to sample landscape groups
- Determine the variability of soil phosphorus, and relationship with other measured variables, with respect to the soil landscape groups

The hypothesis of my MSc thesis is: Soil landscape units can be used to determine fertiliser recommendations to maximise productivity and minimise adverse environmental effects in hill-country in the King Country.





## Chapter 2

# Literature Review

### **2.1 Introduction**

Chapter 2 discusses the relevant literature relating to phosphorus distribution in the steep North Island hill-country of New Zealand. It describes the phosphorus cycle and pastoral properties within hill-country farms, discusses soil phosphorus measurements, soil pH, and other soil chemical properties. The environmental issues related to fertiliser use are also discussed.

### **2.2 Soil Phosphorus**

#### **2.2.1 Introduction to soil phosphorus**

Soil phosphorus takes two forms, inorganic and organic, which vary in accumulation rates, plant availability, and natural occurrence. Total soil phosphorus content is influenced by the individual properties of, and interactions between, parent material, weathering, fertiliser addition, stock, and runoff. Since the advent of aerial topdressing, New Zealand hill-country farms have accumulated phosphorus in the soil which can range between 0.02 to 0.15% of the soil (McLaren & Cameron, 1996).

#### **2.2.2 Inorganic soil phosphorus**

Inorganic phosphorus is in a form that is readily available to plants. Inorganic phosphates can be classified into four main groups; calcium phosphate, aluminium phosphates, iron phosphates, and adsorbed phosphates which are extractable after the removal of the first three forms (Chang & Jackson, 1957). Naturally occurring inorganic (or mineral) soil phosphorus is derived mostly from the weathering of primary apatite mineral. Soil phosphorus in its secondary form

(calcium, iron, and aluminium phosphates) is important for regulating the phosphorus in soil solution (Gillingham, 1987).

### 2.2.3 Organic phosphorus

Soil organic phosphorus levels can vary from 20 to 80% of total phosphorus in the upper layers of the soil (Dalal, 1977). Soil organic phosphorus occurs in chemically diverse forms and enters the soil through the breakdown of organic matter. Soil microbes play an important role in recycling many organic phosphorus compounds, due to their ability to break down soil organic matter. The longer accumulation period of phosphorus in organic matter (compared with carbon, oxygen, hydrogen, nitrogen and sulphur), attributes to the high P content in organic matter.

Organic phosphorus is often overlooked within agricultural systems as organic P is not available for plant uptake (Dalal, 1977). Relative to soils under cultivation, pastoral systems can have high organic P levels, upwards of 50-80% of total soil P. In pastoral systems, the mineralisation of organic phosphorus contributes to the plant available P pool. Allophanic clay soils and higher organic matter soils are generally associated with larger organic phosphorus content (Dalal, 1977) (Stewart & Tiessen, 1987).

## 2.3 ***Phosphorus cycling***

The phosphorus cycle of grazed hill-country pastures is a web of interacting processes in which phosphorus is cycled through soil, plants, and animals (Figure 2.1). The phosphorus cycle is a dynamic system, involving both inputs and outputs. The major inputs of the phosphorus cycle are via additions of fertiliser, dung and litter. Losses from the P cycle are due to animal uptake, erosion, export of animal products, and animal transfer). Internal chemical cycling also plays a part in influencing the availability of phosphorus (Gillingham, 1987).

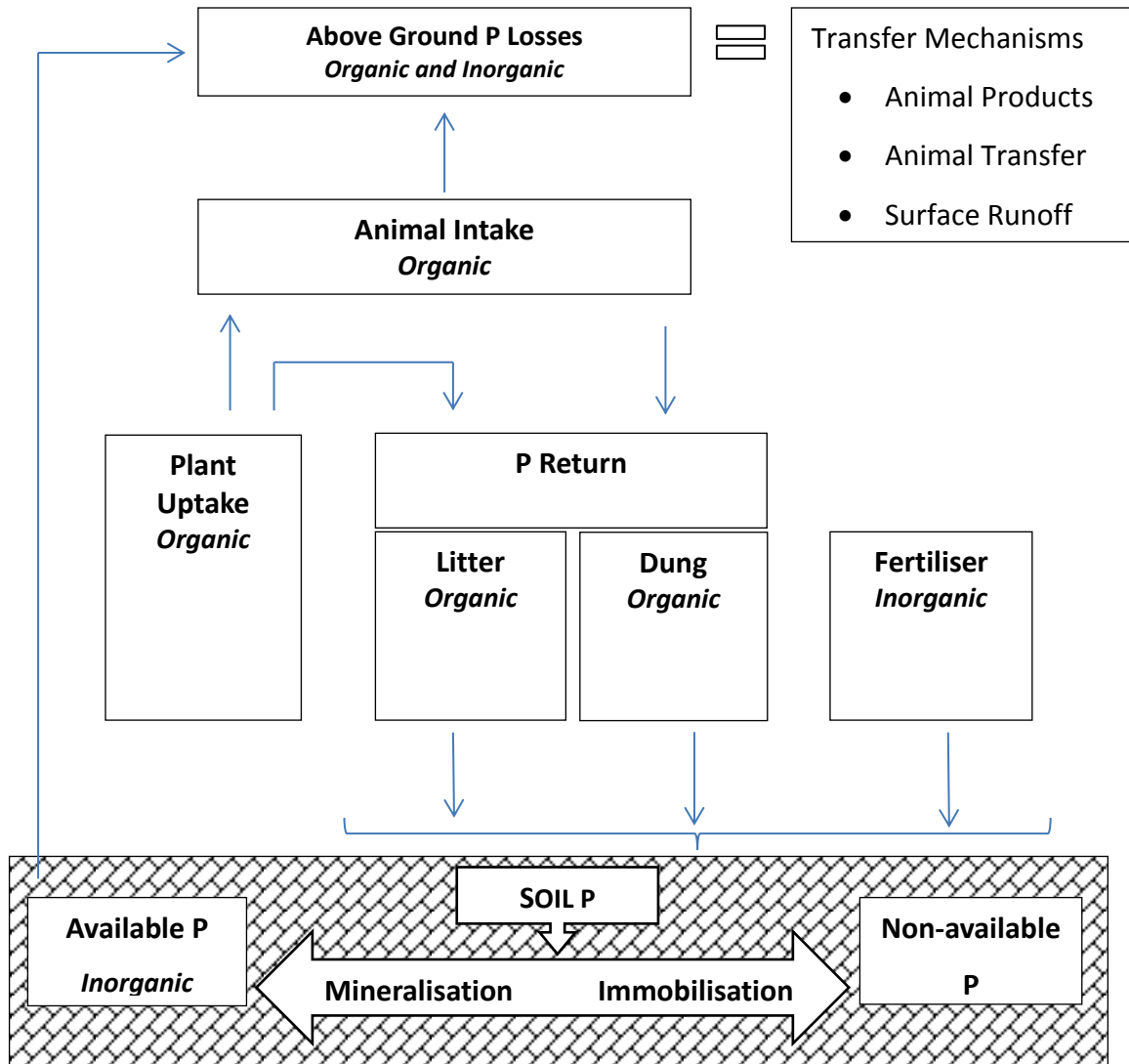

**Figure 2.1** Processes and interactions of the phosphorus cycle (Modified from Gillingham, 1987)

### 2.3.1 Below-ground cycling

Mineralisation and immobilisation cause the cycling of P through organic and inorganic states simultaneously (Perrott, *et al.*, 1992).

#### *a) Mineralisation*

Organic phosphorus must be mineralised to inorganic P forms to enter the plant-available phosphorus pool (Stewart & Tiessen, 1987). The process of mineralisation is facilitated by enzymes; therefore, controlled by factors influencing microbial activity. These factors are; increased temperature, soil moisture, pH and aeration which increase growth of microbial bacteria.

#### *b) Immobilisation*

Immobilisation is the conversion of inorganic phosphorus to organic phosphorus, also known as phosphate fixation, retention, sorption or reversion. The immobilisation of organic P is dependent on the availability of inorganic P and organic substrates for the growth of soil biomass. The proportion of fertiliser P added, which is then removed from the phosphorus pool via immobilisation, is not accurately known, but is likely to be considerable (Cornforth, nd).

Immobilisation and the precipitation of phosphate compounds have the ability to decrease the plant available P from added P fertiliser. Phosphate retention can lead to 50% of added P being fixed and unable to be taken up by plants (Mclaren & Cameron, 1996).

### 2.3.2 Above ground P losses

#### *a) Sources of P*

Above-ground phosphorus loss occurs via three main routes: the export of plant and animal products, the transfer in excreta, and the runoff via soil erosion. Even small variations between farms can strongly impact the above ground losses.

#### *c) Export of plant and animal products*

In New Zealand hill-country, the majority of animals sold are store wether lambs, surplus two-tooth ewes, cull mature ewes, and some weaner and cull-breeding

cows (Gillingham, 1978). Phosphorus is lost via meat (or animal export) and through the sale of wool.

d) *Transfer in excreta*

The uneven distribution of animal excretion over time can influence soil P levels (Saggar *et al.* 1990) (Figure 2.2). The three slope classes used by Saggar *et al.* (1990) were low slope (1-20°), medium slope (13-25°) and steep slope ( $\geq 26^\circ$ ). Each slope class had varying gains, losses, animal intake, excretal return and fertiliser requirements. Greater animal returns were found on low slopes, leading to greater gains compared to medium and steep slopes, regardless of low slopes larger losses of animal product compared with steep slopes.

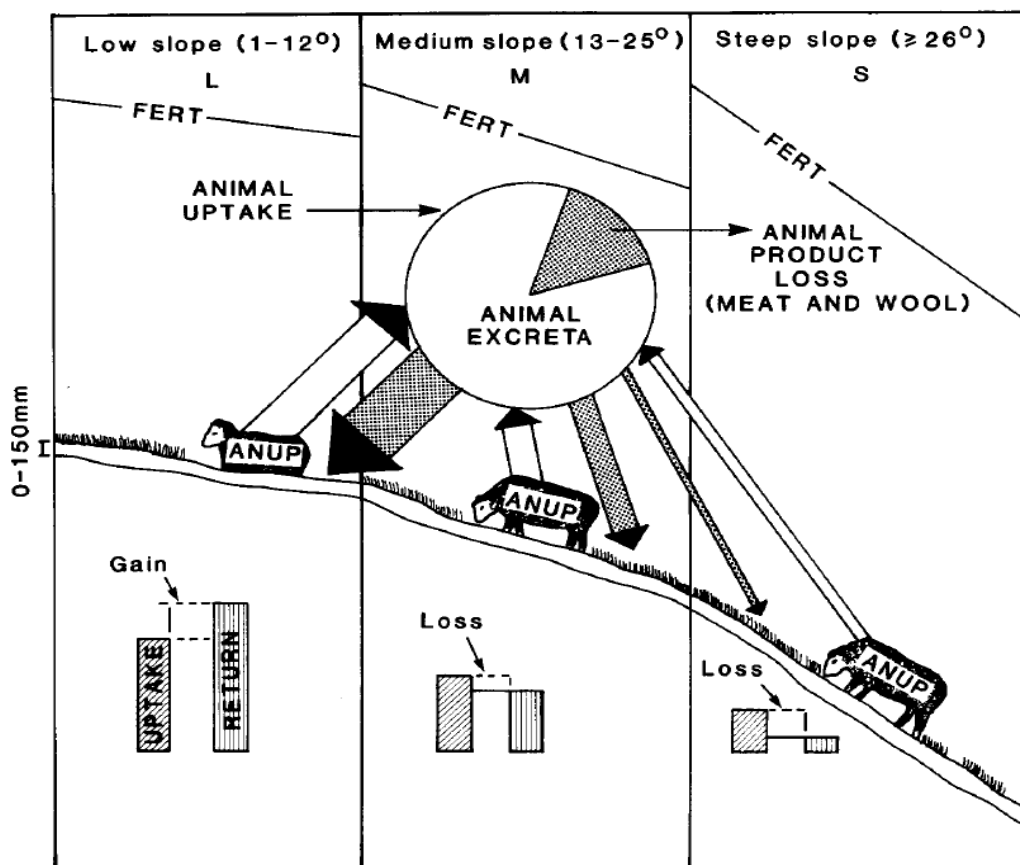

**Figure 2.2** Schematic of nutrient transfers in a grazed hill-country pasture (Saggar, *et al.*, 1990)

A study from the Whatawhata and Te Kuiti research stations reported that 60% of animal dung was distributed over 15% of the paddock; which was predominantly made up of easy slopes (Rowarth & Gillingham, 1990). Of the three slope classes Saggar *et al.* (1990) used, low slopes (31% of the farms area), medium slopes (41% of the total area), and steep slopes (28% of the farms area) to measure excretal return. Of the excretal returns measured in this study, 60% of dung was measured on the low slope, 30% of dung was measured on the medium slopes and 10% of dung was measured on the steep slopes. Consequently, less fertiliser is required on medium and low slopes because of net gains in P concentration due to animal transfer. (Saggar, *et al.*, 1990, Rowarth & Gillingham, 1990). Uneven nutrient distribution influences the phosphorus status of varying slope classes in the hill country. Soil P under campsites can increase by 38% per annum via nutrients transfer from steep slopes. A similar pattern would also be expected for the other nutrients (figure 2.3).

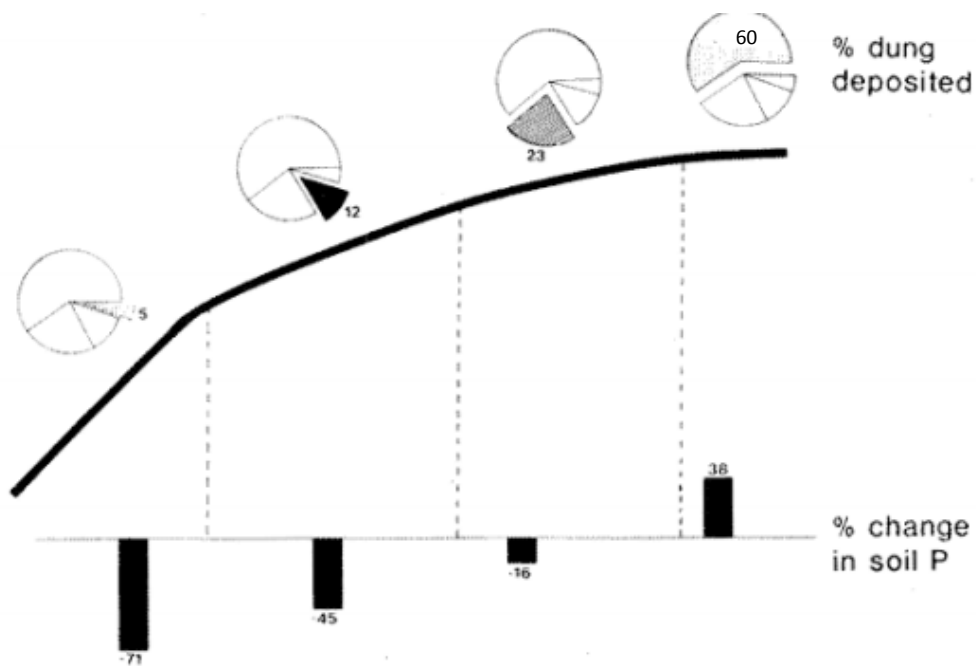

**Figure 2.3** Distribution of dung and change in soil phosphorus on different slopes of hill country pasture (Williams & Haynes, 1990, after Rowarth & Gillingham, 1989)

Saggar *et al.* (1990) created a nutrient model to predict soil P distribution within a farm (Figure 2.4). To determine nutrient transfer levels via animals for each slope class, the model used pasture production, pasture P concentration, pasture utilisation, animal product loss and animal excreta. The predicted change to soil P was then calculated by adding animal transfer levels to fertiliser history.

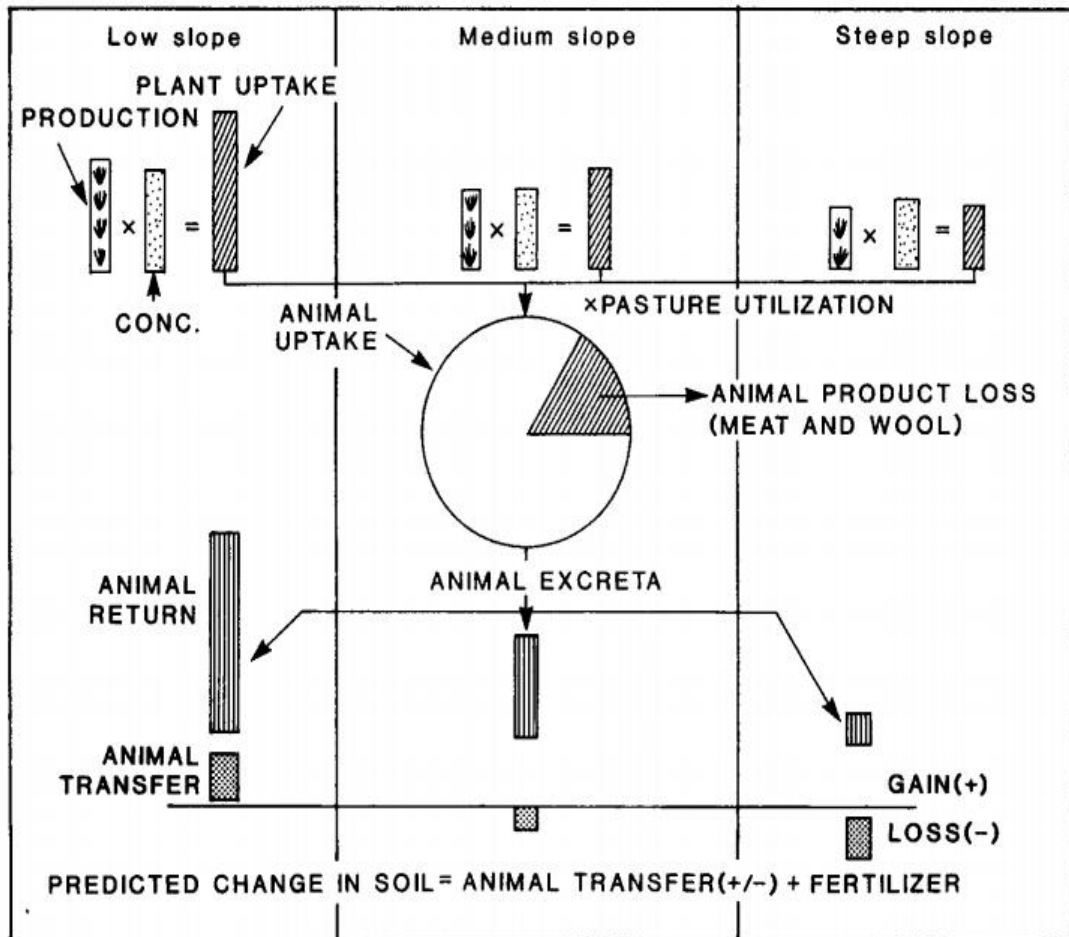

**Figure 2.4** –Schematic of nutrient transfer model in grazed hill country pasture (Saggar, *et al.*, 1990)

#### e) Runoff

Phosphorus is not prone to leaching losses due to it being relatively immobile in soil. This means that the majority of soil phosphorus is lost via runoff. Phosphorus runoff is split into two forms; particulate P loss and dissolved P loss. Phosphorus bound to sediments and organic matter (particle-bound P) makes up



80% of P runoff, and dissolved P accounts for the additional 20% loss (Meneer, *et al.*, 2004, Parfitt, *et al.*, 2009).

Storm events transfer large amounts of soil sediments to waterways and phosphorus bound to these sediments creates particle-bound P loss. Storm events account for 70% of particle P losses within a hill-country system due to the characteristically steep and often easily erodible soils, which is approximately 55% of a hill-country farm's total P loss (McColl, *et al.*, 1977). In contrast, at Ballantrae Hill Country Research Station, the loss of dissolved inorganic phosphorus annually ranged between 9% and 16% of the total phosphorus imported into the system (0.69 to 1.47 kg/ha) (Hart, *et al.*, 2004).

Upon fertiliser application, what is not diffused into soil solution (then into soil matrix) is easily lost due to runoff, owing to the high solubility of the mono calcium phosphate that is found within superphosphate. P runoff can be at risk for between 7 to 60 days after P fertiliser application (McDowell, *et al.*, 2010). McColl & Gibson (1979) measured the P concentration of runoff pre and post fertilisation, finding that P concentrations of runoff post application were 22 times higher than that of pre-fertiliser application runoff. Studies on hill-country farms at Whatawhata and Waipawa have shown that the application of fertiliser increases levels of dissolved reactive phosphorus by 0.06 to 6.4 mg L<sup>-1</sup> at Whatawhata, and 0.46 to 31.5 mg L<sup>-1</sup> at Waipawa (Hart, *et al.*, 2004).

The main factors controlling the runoff/redistribution of P throughout the hill-country are, slope, soil type, soil P status, animal treading, and fertiliser management. The reduction and mitigation of phosphorus runoff is achieved by controlling these factors with five key management systems: P fertiliser management, grazing management, riparian management, post-harvest management, and whole-system management (combination of approaches and advice) (Meneer, *et al.*, 2004).

### 2.3.3 Animal intake

The majority of phosphorus intake by stock is from the pasture species which they consume. Of the plant nutrients ingested by stock, 60% to 90% is returned to the system as excretion (Williams & Haynes, 1997). Factors that influence animal intake are; pasture availability, quality of pasture (young grasses are more palatable and contain more P than older grasses), grazing habits (animal type and frequency of excretion), and farm management (stocking rate, camping behaviour, grazing patterns).

### 2.3.4 Phosphorus returns in litter

The phosphorus quality and content of herbage varies seasonally, species to species, and with plant age. Herbage is returned into the soil predominately by microbial decomposition.

Decomposition rates increase if the P status and temperature are high, and there is an adequate supply of nitrogen either from the plant material itself or added fertiliser (Gillingham A. , 1987). The rapid increase in microbial population creates addition to the inorganic phosphorus pool due to the input from young plant material.

### 2.3.5 Phosphorus returned in dung

Sheep faces contain plant available phosphorus, which when incorporated into the soil, is as effective as superphosphate (Barrow, 1987). Understanding animal behaviour, pasture utilization, and animal transfer is vital to understanding dung distribution. The phosphorus content within excreta is controlled by the quality, and consumption of herbage. Sheep on hill country tend to graze steeper slopes but camp/congregate on flatter areas (Haynes & Williams, 1999). This causing dung and urine from grazing animals to accumulate around animal camps, ridges, trees, troughs, gateways, and areas conducive to animal congregation (Sigua, et al., 2011, Haynes & Williams, 1999).

Due to the majority of stock excretion occurring at night, areas where animals camp are hot spots for phosphorus return. Ingrained predatory responses create tendencies for stock to camp on flat, elevated sites. The transfer and redistribution of P due to livestock represents a large proportion of nutrient cycling within a farming system; therefore, it is important that the habits of livestock on hill-country farms are clearly understood (Lemunyon & Daniel, 2002).

Management techniques to decrease uneven dung distribution include dividing paddocks into slope classes, increasing stocking rate, and more intense farming practices (subdivision and rotational grazing, as opposed to low stocking rate and set stocking). Uniform dung distribution and consequently lower fertiliser requirements provide for simpler fertiliser regimes, provided that evenly spread fertiliser is the best option (Thorrold & White, 1985, Williams & Haynes, 1990).

#### 2.3.6 Plant uptake of phosphorus

Plants uptake inorganic P (readily available) and convert it to organic P (non-available P). Once the plant dies and decomposes, this organic P is then converted back to inorganic P by microbes. Plant uptake of phosphorus occurs via three basic methods in which nutrients make contact with the root surface; root interception, mass flow, and diffusion. The amount of P plants intake via these methods is dependent on root distribution and density (Gillingham, 1987, Gillingham, 1978). Roots with larger distribution and denser systems are able to extract larger volumes of phosphorus from the soil, giving them the competitive edge. As well as dense root systems, vesicular-arbuscular mycorrhizal fungi can increase the surface area of the roots, therefore, further increasing the volume of phosphorus uptake.

Phosphorous uptake can vary from plant to plant due to individual phosphorus extraction efficiency. Plants in low phosphorus soils are efficient at P extraction, as opposed to the low P extraction efficiency of pasture plants that naturally grow in soils with high phosphorus levels. In hill-country soils where P and

fertility is naturally low, pasture species like White clover are efficient at P uptake (Gillingham, 1987).

### 2.3.7 Fertiliser additions

Many types and concentrations of phosphorus fertiliser are available in New Zealand, all originating from phosphate rock deposits (McClaren & Cameron, 1996). Phosphorus fertiliser is applied in inorganic form, and either taken up by plants or incorporated into soil by microorganisms. Phosphorus entering farming systems via fertiliser and/or dung at a rate higher than is removed, leads to phosphorus accumulation. A depletion of P occurs when the addition of fertiliser and/or dung does not exceed the amount of P being removed from the system (Saggar, *et al.*, 1990).

Natural phosphorus deficiencies within New Zealand soils create a requirement for phosphorus fertiliser if maximum pasture production is to be attained. However, the application of fertiliser on New Zealand hill-country farms is often not sufficient to build up soil nutrient reserves. Limiting soil nutrient reserves, decreases soil fertility, leading to lower animal and pasture production

Perrott *et al.* (1992) studied the effects of P fertiliser on organic cycling and microbial biomass in hill-country soils under pasture. When fertiliser was withheld, pasture production markedly decreased due to a lack of natural organic phosphorus utilisation (mineralisation), depleting inorganic phosphorus stocks. The addition of P fertiliser increased pasture production and microbial phosphorus. The increase was possibly the result of an improved supply of root exudate, allowing for an increase in microbial activity. Whether fertilised or not, organic phosphorus was not utilised and resulted in a substantial accumulation of soil organic phosphorus (10-12 kg P ha<sup>-1</sup> year<sup>-1</sup>) (Perrott, *et al.*, 1992).

The higher phosphate retention (>84%) of Allophanic Soil requires more fertiliser to maintain soil nutrient levels than soil with medium (60-84%) and low (10-59%) phosphate retention. High P-retention soil require  $6\text{kg ha}^{-1}$  more P than a low P-retention soil. When using superphosphate (9% P content), this translates to an increased application cost of  $\$30\text{ ha}^{-1}$  (2011 price) for a soil with high P-retention, which on a 1000 ha farm equates to  $\$30,000$  (Fraser & Vesely, 2011, Cornforth I. , 1998).

## ***2.4 Pastoral properties of New Zealand hill-country farms***

### ***2.4.1 Introduction to pastoral properties***

Soil fertility is the main factor influencing pasture production on hill-country farms (Gillingham, 1980). Soil fertility is influenced by slope, aspect, altitude, climate (temperature, rainfall, and solar radiation) and grazing management, which all vary widely within hill-country (Fraser & Vesely, 2011). Knowledge of the factors influencing soil fertility, and their variability within the landscape, can help create effective differential fertiliser regimes.

### ***2.4.2 Varying pasture production driven by slope, aspect and altitude***

Aspect and slope variations are driven by solar radiation and wind, which influences precipitation and moisture losses, heat balances, soil-forming processes, and pasture composition. All factors combine to influence pasture production (Radcliffe & Baars, 1987).

Soil moisture is a large contributing factor to increased pasture growth. Differences in soil moisture are associated with varying aspects. South facing slopes are cool and have high soil moisture content, leading to increased White clover growth. While the warmer, dryer, north facing slopes are dominated by Subterranean clover and native legumes (Gillingham, *et al.*, 2003b, Gillingham, *et al.*, 2008ab). The summer soil moisture of a Waipawa hill-country farm was higher on south facing slopes than on the north facing slopes (Gillingham, 2003).

Low slopes have higher pasture production than steep slopes, regardless of aspect. For a hill-country farm on the east coast of the North Island of New Zealand, pasture production on north-facing slopes (especially low slopes) was higher than that of any other slope and aspect class (Gillingham, *et al.*, 1998, Gillingham, *et al.*, 2007). At Whatawhata Hill-country Research Station, pasture production on campsites was double that of the pasture production on 45 ° slope (Gillingham, 1980). Slopes above 26° require 1.1 kg P to produce one stock unit, however, flat land only requires 0.3 Kg P (Gillingham, *et al.*, 1999).

### 2.4.3 Climatic influences on pasture production

In many hill-country pastures, between 60 to 80% of total annual pasture growth takes place within three to four months of the year, mostly from spring through to early summer. The lowest pasture growth occurs during winter and late summer (Gillingham, 1980, Rattray, 1987). The best techniques for dealing with seasonal changes to pasture production are to take advantage of times of high soil moisture, as well as conditioning pasture to grow when soil moisture is low (Gillingham, 2003).

Seasonal climatic variation can influence rates of bacterial growth, thus influencing organic phosphorus. Perrott *et al.* (1992), reported that organic phosphorus increased with decreasing temperatures (winter-spring), and decreased when temperatures increased (spring-summer). Increased soil moisture (winter-spring) and low microbial activity rate combine to create an accumulation of labile organic phosphorus (solid phase phosphate that is readily able to move into solution (McLaren & Cameron, 1996)). High temperatures (summer) increased the availability of root exudates used as substrate for bacterial growth, improving the environmental conditions at that time and reducing the amounts of microbial P and release of inorganic phosphorus.

Legume content can drive overall production and quality of hill-country pasture. Low clover content translates to a decrease in pasture quality (Gillingham. *et al.*, 2008b). Hill country studies have shown that the most reliable clover production response to fertiliser was in early spring (Gillingham *et al.* 2007, Saggarr, *et al.*, 1990, Dalal, 1977). The increased production was due to favourable temperature, rain and subsequent soil moisture, for pasture growth. Gillingham, *et al.*, (2007) also showed an increase in clover production with increasing Olsen P.

#### 2.4.4 Management options for improved pasture production

Optimised grazing management and improved soil fertility are two management techniques that have the potential to improve pasture production within the hill-country. The basis of grazing and soil fertility management is to enhance the quality and quantity of pasture, which leads to increased animal health and production (Lambert, *et al.*, 2004).

##### *a) Grazing management*

Rotational grazing and set stocking are two common methods of grazing management on hill-country farms. Set stocking systems produce less dense pasture than rotational grazing. Suckling (1959) stated that the increase in density of set stocking systems is so much that it has the potential to depress herbage accumulation rates. A later study by Lambert (1986) dismissed Suckling (1959) results. Finding that when sheep were rotationally grazed under high stocking rates, pasture density was not reduced to an extent that herbage accumulation rates was less than if the same area had been set stocked. Setting high stocking rates in combination with rotational grazing minimises legume shading while maximising pasture utilization (Gillingham, 2003).

Grazing management techniques are well established in most hill-country farms, however, trials have proven them to have little effect on legume performance. Hill-country farms are constrained by economic and practical considerations, especially those of animal nutrition, individual animal performance, and area productivity, to a limited range of defoliation and treading intensities and frequencies (Lambert, 1986).

*b) Fertiliser management*

The application of P fertiliser generally increases legume concentration in pasture, allowing for increased atmospheric nitrogen fixation (Blackmore, et al., 1969; Suckling, 1959; Lambert & Grant, 1980; Edmeades, 1984). Superphosphate increases pasture production and allows for a substantially increased stocking rate, leading to increased animal production. Results from a hill-country study by Gillingham, *et al.*, (1998) showed that pasture response to fertiliser varied between north and south aspects; high pasture response on south facing aspects and north facing medium slopes. The increases in pasture production due to phosphorus fertiliser application also varied with slope. Hill-country farm trails at Whatawhata and Waipawa (Table 2.1) illustrate increases in pasture production in relation to increases in Olsen P tests, on both steep and easy slopes. The response of pasture production to increasing P fertiliser inputs on steep slopes was half that of the response from easy slopes, at both Whatawhata and Waipawa. On steep slopes, pasture production increases due to fertiliser inputs was not significant, meaning further P fertiliser application will likely not result in a positive pasture response (Gillingham, 2003).

**Table 2.1** Average annual pasture production (kg DM/ha) on easy and steep slopes with increasing Olsen soil P for contrasting locations (Gillingham, 2003)

<b>Whatawhata*</b>	<b>Olsen P = 8</b>	<b>Olsen P = 11</b>	<b>Olsen P = 30</b>	<b>SED ***</b>
<b>(1985-88)</b>				
Easy (10 - 20°)	12 000	13 000	14 750	4.3
Steep (30-40°)	8 150	7 500	8 500	365
<b>Waipawa**</b>	<b>Olsen P test = 9</b>	<b>Olsen P test = 15</b>	<b>Olsen P test = 28</b>	<b>SED</b>
<b>(1995-2002)</b>				
Easy (15-25°)	3 700	4 300	4 900	2.5
Steep (25°+)	2 000	2 200	2 700	478

\* Average from 0-30 and 30-70mm soil depth

\*\* 0-75mm soil depth

\*\*\* standard error of the difference



Edmeades' (1984) study of phosphorus requirements for hill-country yellow-brown earths demonstrated that to maximise production and ensure efficient use of fertiliser P in terms of pasture production per unit of P applied, it is important that pasture is vigorous and have a good legume base.

#### 2.4.5 Phosphorus requirements for hill-country pasture

Edmeades, et al (1984) stated that at an Olsen P of 13, clover/ryegrass could reach 90% maximum pasture production while a recent optimal Olsen P of 20 was suggested by Ledgard, *et al.*, (1991).

#### 2.4.6 Pasture composition

Pasture composition of New Zealand hill-country comprise of lower fertility grass species such as Brown-top, Yorkshire Fog, Sweet Vernal and Crested Dogstail Perennial Ryegrass, and Cocksfoot. Hill country legumes include White clover, Subterranean clover, and lotus (Charlton & Belgrave, 1992) (Chapman & Macfarlane 1985).

White clover (*Trifolium repens*) was the most commonly planted legume following the early development of pasture. White clover is able to fix nitrogen which is then supplied to the pasture (Williams & Haynes, 1990). Brown-top is a major grass species present in hill-country ever since the beginning of New Zealand pastoral farming (Brougham, *et al.*, 1974).

### **2.5 *Differential application of fertiliser in hill-country***

Aerial fertiliser application in New Zealand began in the early 1950's, with the uniform application of fertilisers over hill-country farms (Gillingham, *et al.*, 1999). Spatial nutrient variability is not taken into account when applying fertiliser uniformly, leading to the over-application of P fertiliser on low production areas and the under application on high production areas (Gillingham, *et al.*, 1999, Gillingham *et al.*, 2003). The incorrect application of fertiliser leads to both environmental and economic degradation. Fertiliser is one of the single largest expenditure items on hill-country farms. Between 2007 and 2010, the cost of

superphosphate approximately doubled. Due to the increasing cost of fertiliser and current economic climate, farmers are looking at better ways to apply fertiliser without forfeiting pasture production and environmental health (Fraser & Vesely, 2011).

### 2.5.1 OVERSEER

OVERSEER is a model used to optimise production and environmental outcomes through the examination of nutrient movement and use. The five main objectives of overseer are (AgResearch, 2012);

1. Identifying nutrient transfers and pathways
2. Use scientific reasoning and robust processes to model pathways
3. Uniformity throughout farming systems
4. Usability for the farming community
5. Mitigation options

AgResearch used the results of a large number of trials, creating definitions of an average, standard and relative response curve. The response curves, Olsen P, stocking rate and other site related variables are able to be used in conjunction, to define phosphorus fertiliser requirements (Gillingham A. G., 2001)

### 2.5.2 Fertiliser management using GIS and GPS

#### *a) GIS*

GIS (Geographical Information System) is computer software used for creating geographically referenced information. Hill-country farms are able to use GIS mapping techniques to display critical farm information and create specific landscape units. The maps can then be used to generate fertiliser response blocks and ideal fertiliser regimes.

#### *b) GPS*

GPS uses triangulation by receiving signals from three or more satellites to determine its distance from them relative to the earth (Gillingham, *et al.*, 1999).

A combination of GIS, GPS and farm information, allows the accuracy of fertiliser application to increase relative to regular blanket application. GPS is able to determine the ground speed relative to the speed an aircraft is travelling, which allows varied fertiliser application through automatic hopper adjustment. Therefore, the use of both GPS and GIS can create accurate and deliberate adjustment to fertiliser application along aircraft flight paths, allowing for the contrasting fertiliser requirements of landscape groups to be met (Gillingham, *et al.*, 1999).

*c) Precision fertiliser application*

In the North Island hill country, financial and environmental pressures are creating the need for farmers to apply less phosphate fertiliser where soil fertility is high, which creates an opening for GIS and GPS technology (Stantiall, 2006). Traditional blanket fertiliser application can lose 10–15% of fertiliser unintended areas; gullies, steep faces, fenced off areas, swamps and streams. The benefits of precision fertiliser application not only reduce wastage, but can decrease cartage and fuel costs (Gillingham *et al.*, 1999).

Gillingham (1999, 2001) outlined the three main components required for efficient differential fertiliser management. Firstly, spatial variation of each landscape unit must have temporal longevity, so that it is worthwhile to treat different landscape units as separate entities. Secondly, the varying management practise of each landscape unit must be based on pasture response trial or through a modelling approach. Lastly, differential fertiliser recommendations must be based upon quantitative results.

Gillingham, *et al.*, (1999) studied the effects of differential fertiliser application on a low P status Manawatu moist hill-country farm, and a high P status East Coast summer dry hill-country farm. The results illustrated that using the same quantity of fertiliser, but applying it differentially, could lead to increases in pasture production, stocking rate and net economic margin. Farm with a low soil P status can increase stocking rate by 0.5 su/ha and economic return by 7.5%.

Farms with higher soil P status, can increase stocking rate by 0.9 su/ha and economic return by 10.1% (Gillingham *et al.*, 1999).

The potential savings of differential fertiliser application have been estimated by Fraser and Vesely (2011) using Waikoha Hill-Country Station (Table 2.2). Waikoha's underlying geology comprised tertiary sandstone, siltstone and limestone with tephra deposits. Parent material mixing has created a mosaiced of soil types. Table 2.2 illustrates the varying cost of raising the Olsen P by 6 units using the precision fertiliser application technique, compared with blanket fertilising. By using the soil specific fertiliser application, the cost of raising Olsen P by 6 units would be \$671,292, compared with \$1,065,978 it would have been if fertiliser was applied to high phosphorus retention with blanket application. The \$394,686 saving demonstrates the economic advantage of using targeted fertiliser application (Fraser & Vesely, 2011).

**Table 2.2** The variation in fertiliser and application costs between targeted fertiliser application of varying soil p-retention levels compared with blanket fertiliser application of high P-retention soils (blanket high) or low P-retention soils (blanket-low) – hypothetical situation (Fraser & Vesely, 2011).

	High P-ret	Med P-ret	Low P-ret	Total	Blanket high	Blanket Low
<b>Area (Ha)</b>	450	472	2,078	3,000	3,000	3,000
<b>Maintenance Cost (\$)</b>	32,479	27,680	93,739	153,897	207,996	129,997
<b>Development Cost* (\$)</b>	133,977	102,201	281,216	517,394	857,982	389,992
<b>Maintenance + Development (\$)</b>	166,456	129,881	374,955	671,292	1,065,978	519,989

\* Based on raising Olsen P by 6 units

Gillingham *et al.*, (1998, 1999) suggested that the most efficient fertiliser policy would be for only south aspects, and moist north aspects to receive P application, and for steep north facing slopes to receive limited P. Findings also showed that the greatest response to P fertiliser was from easy slopes (15-20) increasing it

pasture growth 1670 kg/ha over steep slopes. Suggesting that easy slopes should receive priority fertiliser application.

Issues of differential fertiliser development are;

1. The cost of equipping aircrafts with GPS technology. Gillingham *et al.*, (1999) estimated an additional cost of \$3.52/ha for imposing the new fertiliser technology, still however, making it profitable for farmers.
2. The minimum size dimension of aerial application. The topographic variability over small scale of many hill-country farms means that the 20m wide fertiliser units used by Gillingham *et al.*, (1999) could be pose application difficulty. Hill-country farms are likely to have many areas that are too small to treat separately, bringing about the issue of pragmatism.
3. The third issue is the accuracy of application boundaries due to the physical form of fertilisers. Fertilisers with higher granulation have the narrowest boundary widths (Gillingham, et al., 1999).

### 2.5.3 Soil mapping and its implications for differential fertiliser application

Soil mapping can influence the effectiveness of differential fertiliser application. Due to soil fertility being a component of pasture production, placing the optimum amount of fertiliser on the appropriate soil type could allow for pasture maximization. Once a soil type has been sampled and the limiting nutrients analysed, farm-scale soil mapping would be able to accurately target P fertiliser. The problem being that the North Island hill-country does not have soil mapping with enough detail to be used as a practical management tool (Fraser & Vesely, 2011). Soil mapping is made difficult by the mosaic of intermixed soil types with varying parent materials; sedimentary, calcareous and tephric origins.

Fraser and Vesely (2011) created a farm scale soil map on a 3500 ha farm, Waikoha Station. The total cost of creating the farm scale soil map was \$3 ha<sup>-1</sup>, approximately \$10, 500 for the entire farm. The cost was made up by time spent; reviewing relevant soil and geological surveys, conducting field work, and

creating GIS layers. Though it was a small area detailed mapping exercise, mapping whole districts or regions would most likely cut the price per hectare and become more cost effective.

Fraser and Vesely (2011) discussed the concept of using pasture production to break down hill-country farms into various fertiliser response blocks; steep land, moderate slopes, easy slopes and stock camps. Steep land had the lowest potential fertiliser response, and highest runoff risk. Moderate slopes had the potential to respond well to fertiliser dependent on soil type. Easy slopes will gain the most benefit from fertiliser. Application of additional fertiliser is not necessary in stock camps where soil fertility is not a limiting factor.

## **2.6 Soil P measurement Methods**

### **2.6.1 Introduction**

Soil testing determines whether or not the soil has adequate nutrient levels to attain maximum pasture production, evaluates the balance of soil nutrients, and allows for empirical fertiliser recommendations (Hill Laboratories, 2012a).

### **2.6.2 Olsen P Measurement**

Since the mid 1970's, the Olsen P test has been used to measure plant available phosphorous, and determine the amount of labile inorganic phosphate in soils (Sinclair, *et al.*, 1997). The practical use of the Olsen P test is to predict pasture response to phosphate fertilisers and assist in calculating pasture P requirements (McLaren & Cameron, 1996). Olsen P is a necessary requirement for OVERSEER to generate a nutrient budget (Ledgard, *et al.*, 1999).

Sinclair *et al.* (1997) stated that there is little relationship between Olsen P and relative yield, and little variance between soil types. Claiming Olsen P can account for 28% of variation in relative pasture yield, and only when the Olsen P levels are greater than 20, will the relative yield be high. Sinclair *et al.* (1997)

concluded that the relationship between relative pasture yields and Olsen P was too varied for the use of fertiliser recommendations, and should only be used to predict the probability of a specified recommended yield not being achieved without the use of fertilisers. The poor relationship between Olsen P and relative yield could be due to several factors. These factors could be; measurement errors at study sites, the independent change over time of a single site, or and/or the study sites relationship varies at different sites

Edmeades *et al.* (2006) however, showed that pasture production on Pumice Soils, Allophanic Soils and Recent Soils increased with increasing Olsen P. Peak relative pasture production for Pumice Soil was achieved at an Olsen P of 20, and Brown Soil can reach 95% of its maximum yield with an Olsen P of 11.5 (Gillingham's *et al.*, 2007).

Olsen P can be measured using air-dried or field-moist soils. Variations between air-dried and field-moist Olsen P were recorded in a study by Perrott *et al.* (1992) measuring on average of 3.9 units higher for air-dried soils than field-moist soils. The difference was thought to be due to the microbial P released in the process of soil drying. A modified Olsen test uses a volume of soil opposed to a weight for its extraction process, leading to a superior correlation with either plant yields or plant P uptake (Edmeades, *et al.*, 2006).

Truog, Olsen, Bray 1 and Bray 2, and Egner are the five most common soil test methods used to measure pasture response to phosphorus fertiliser. Saunders, *et al.*, (1987) compared each five soil tests on New Zealand's three major soil groups (yellow-brown loam, yellow-brown pumice soils, and yellow-grey earth). Of the five soil tests, Olsen P (using a volume of soil) gave the best prediction of probable minimal yield.

### 2.6.3 Phosphorus buffer capacity

Phosphorus buffer capacity is the capacity of a soil solutions phosphate concentration to resist change when soil phosphate is added or removed. The

larger the phosphorus buffer capacity, the more phosphorus bound to the soil, creating less P available to the plants (Burkitt, *et al.*, 2002). Phosphorus buffer capacity influences the amount of added phosphorus fertiliser available for plant uptake. Solution P concentration is the main determinant of P availability to crops. The increase of P buffer capacity increases, the quantity of P necessary to maintain solution P concentration that crop demand. (Moody, 2007).

The phosphorus buffer capacity of a soil can influence Olsen P levels. For many New Zealand soils (Volcanic, Sedimentary and Recent soils), a lower P buffer capacity gives higher Olsen P levels for the same amount of P added. As a soil's buffer capacity decreases, the need for additional fertiliser decreases; reducing money spent on fertilisers and reducing leaching into water ways.

#### 2.6.4 Anion Storage Capacity

Anion storage capacity (ASC), previously termed phosphate retention, measures a soil's ability to retain anions, like phosphates and sulphates, which are negatively charged nutrients. Soils with high anion storage capacities, like volcanic soil, will retain more phosphates and sulphates than sedimentary soil with a low ASC. If a soil has a high ASC, then it will retain sulphate better than one with a low ASC (Morton, 2012). ASC is measured on an arbitrary 0-100% scale (Rayment & Lyons, 2011). Fixation occurs due to the precipitation of soil phosphorus as insoluble P compounds, soil clays and/or organic matter bind tightly to soil P inhibiting the uptake of soil P by plant roots, or the incorporation of soil P into very stable soil organic matter (Quin, 2010).

The anion storage capacity of Allophanic Soils in New Zealand have a typical range between 90-100, while 20-30% is a standard ASC level for a sedimentary soils. Two to three times the amount of capital P fertiliser is required for soil with high ASC than low ASC soils.



## **2.7 Other Soil Chemical Properties**

### **2.7.1 Soil Ph**

Soil pH is expressed as the concentration of hydrogen ions, with the pH scale being a base 10 exponential scale. Acidic soils have higher hydrogen ion concentration than hydroxide concentration and vice versa for alkaline soils (Singer & Munns, 2006)

Soil pH is termed 'the controlling variable' due to its ability to govern the availability of most essential nutrients; cation exchange capacity, active and reserve acidity and buffering capacity (Cornfort & Frank, 2000, Ashman & Puri, 2002). Thompson, *et al.*, (1973) stated that soil pH has little direct effect on plant growth; however, by influencing the availability of macro-nutrient, soil pH can indirectly impact plant growth (Figure 2.5) (Brady & Weil, 2008).

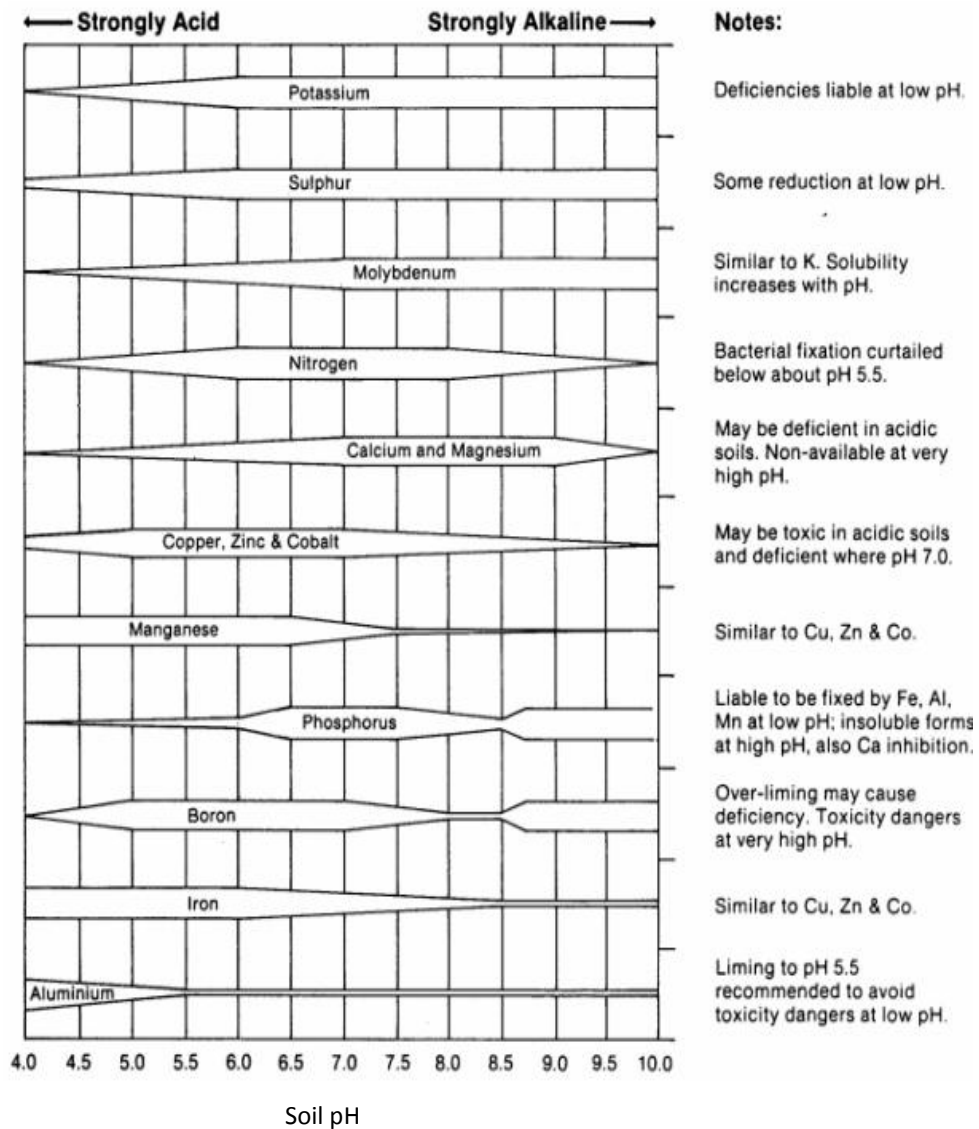

**Figure 2.5** A schematic illustration of the relationship between plant nutrient availability and soil pH (Hill Laboratories, 2012c) after (Truog, 1948)

The rate of mineralization is enhanced by adjusting the pH such that it is optimum for general microbial metabolism, as the soil pH is increased, microbial activity is markedly increased. Mineralization of soil organic phosphorus increases following the liming of acidic soils (Dalal, 1977, White, 1987). Soil pH has the propensity to decrease with development, hence the need for regular application of lime every 2 – 4 years to maintain an optimal level of pasture production (Williams & Haynes, 1990).

### 2.7.2 Cation exchange capacity

Cation exchange capacity (CEC) is the soil's ability to hold exchangeable cations, a measure of a soil's ability to retain nutrients (Singer & Munns, 2006). Soil pH effects CEC, as soil pH decreases,  $H^+$  attach to the colloids and other cations are pushed off into the soil solution, decreasing the cation exchange capacity. When soil pH is low, only the permanent charges on 2:1 clays, 1:1 clays, and some pH dependent allophone and organic colloids are able to hold exchangeable ions.

CEC influences soil pH buffering capacity. The pH buffering capacity is the amount that a soil resists a change in pH, mostly due to the size of the cation exchange capacity and amounts of  $H^+$  in reserve (Mclaren & Cameron, 1996). Changing the  $H^+$  concentration of soil means that the equilibrium balance is upset, therefore, the soil acts to re-establish the cation exchange equilibrium by moving  $H^+$  to and from the reserve and active sites. Therefore, the change in  $H^+$  will always be smaller than the amount of  $H^+$  increased or decreased initially, which is referred to as being buffered against any changes in the soil's pH.

### 2.7.3 Sulphate-sulphur

A soil's sulphate-sulphur level is used as a measure for readily available sulphur. Sulphate-sulphur concentration are influenced by mineralisation, dung and urine patches, and fertiliser addition. Sulphate sulphur has a high level of mobility in the soil, therefore, is a largely varying, fluctuating variable (Hill Laboratories, nd).

### 2.7.4 Organic sulphur

Of total soil sulphur, 97% is in organic form. Organic sulphur is the measure of medium-term available S and the readily soluble fraction of the organic S pool (Hill Laboratories, nd).

### 2.7.5 Cations – Magnesium, Sodium, Potassium and Calcium

Magnesium, potassium and calcium are all essential base micro nutrients for plant growth. Sodium is not an essential plant nutrient required for plant growth.

However, it is required for optimal animal health and production (Edmeades & O'Connor, 2003). Cations within soil influence the way that nutrients move from the soil to the roots. The three basic methods in which nutrients make contact with the root surface for plant uptake are root interception, mass flow and diffusion.

## **2.8 *Environmental issues related to fertiliser use***

Small amounts of runoff into waterways can be detrimental to the environment (Hart, *et al.*, 2004). Phosphorus runoff from agricultural land is a major cause of non-point-source pollution. Pollution from phosphorus runoff causes contamination of streams and lakes, which can lead to accelerated eutrophication. Eutrophication and pollution to waterways leads to the degradation of aquatic animals and their habitats, drinking water and water recreation (Daniel, *et al.*, 1998). Efficient fertiliser application by means of differential fertiliser application can help reduce runoff into aquatic systems (Gillingham, Morton, & Gray, 2003).

The Sustainable Land Use Initiative (SLUI) aims to protect soil and farm assets from storms. Soil losses can have an effect on the rural economy and require government aid and relief (following storm events). Encompassed in the SLUI plan are Whole Farm Plans (WFPs), which aim to build both environmental (soil, land, water, and vegetation) and economic (farm business) sustainability, and entertains the notion that these two elements are interrelated and should not be treated individually (Horizons Regional Council, 2007)

Within phosphorus fertilisers are many impurities which occur due to the original material used to make the fertilisers. Table 2.3 from McLaughlin *et al.* (1996) illustrates the mg/kg dry weight content of individual elements within phosphate rock, and its comparison to that found within the earth's crust.

**Table 2.3** Heavy metals and other potential toxic elements in rock phosphate, compared with averages in the earth's crust (McLaughlin, Tiller,

Element	Rock phosphate		Earth crust average value
	Minimum	Maximum	
As	2	300	5
Cd	1	90	0.5
Co	0.2	21	30
Cr	6	327	200
Cu	20	98	100
F	1900	42400	270
Hg	0.4	2.1	<0.1
Mn	5	524	900
Mo	<1	5	3
Ni	9	51	80
Pb	<1	51	16
Sb	0.1	3	<1
Se	<1	12	<1
Sn	<1	52	40
Sr	420	24800	400
Ti	265	1471	6000
V	10	248	150
Zn	<2	2412	50
Th	1	110	8
U	<1	280	3

A review of the environmental impacts caused due to fertiliser addition by McLaughlin *et al.* (1996) showed the risk of increased contamination concentration due to fertilisers. They concluded that fluorine, mercury and lead pose negligible risk of toxicity due to accumulation. However, cadmium was the element of most concern.

The accumulation of cadmium in soils is affected by the concentration of cadmium within the fertiliser. Within recent years, the use of lower cadmium concentrated fertilisers, and plant cultivars that restrict cadmium uptake, have helped reduce the accumulation of cadmium by plants. Increased cadmium concentrations are a risk due to the transfer from soil to plants to animals, intended for human consumption (Lognanathan, *et al.*, 1996).

## 2.9 Summary and Conclusion

Soil phosphorus occurs in two forms, organic and inorganic. The organic form of phosphorus is unavailable for plant uptake, but when mineralised is added to the plant available phosphorus pool. Inorganic phosphorus is readily available for plant uptake, but when immobilised it is converted to organic phosphorus. The phosphorus cycle is a dynamic system involving both inputs and outputs. Phosphorus inputs are dominated by the additions of fertiliser, dung, and dead plant material. Phosphorus losses mainly occur due to animal intake, erosion, export of animal products and animal transfer. Stock excretion predominantly occurs on lower slopes, increasing the transfer of nutrient and pasture production, when compared with medium and steep slopes (Rowarth & Gillingham, 1990). A study by Saggar *et al.* (1990) on a North Island hill country farm documented that 60% of animal excretion occurred on low slopes, 30% occurring on medium slopes and 10% on steep slopes. Losses to the phosphorus cycle mainly occur due to overland erosion/runoff. Phosphorus runoff consists in two forms, particulate and dissolved. Particulate runoff makes up 80% of total runoff, of which 70% is due to large scale storm events. The remaining 20% of total runoff occurs via dissolved P (Meneer, *et al.*, 2004, Parfitt, *et al.*, 2009).

New Zealand North Island hill country is characteristically nutrient deficient, often requiring fertiliser additions to reach optimal pasture production. Influences on pasture production and stock transfer are dominated by slope, aspect, altitude, climate and grazing management differences. South facing slopes are cool and have high soil moisture content, allowing for the increased the presence of White clover. North facing aspects have the highest pasture production levels, due to their warmer, drier environment that is dominated by Subterranean clover. Low slopes have the highest pasture production out of all slope classes. The best overall response to fertiliser was spring to early summer. Unlike pasture production, south facing slopes had the best response to added fertiliser.

For hill country farms to reach optimal pasture production, recommended Olsen P levels were suggested. Edmeades, et al., (1984) suggested an Olsen P of 13, whereas more recently Ledgard, et al., (1991) recommended an optimal Olsen P levels of 20. Saunders, *et al.*, (1987) demonstrated that out of Truog, Olsen, Bray 1 and Bray 2, and Egner P, the best phosphorus test to measure pasture response to fertiliser was Olsen P. Edmeades *et al.*, 2006 showed that pasture production increases with increasing Olsen P levels. To achieve optimal Olsen P levels, fertiliser management is vital.

Technological advances in GIS and GPS have given aerial fertiliser applicators more precision than ever before. With the aid of GIS and GPS, differential fertiliser application is able to be accurately and deliberately adjusting along an aircraft's flight paths. Increased accuracy allows for contrasting landscape nutrient requirements to be individually met. Typically, single rate fertiliser application (Blanket fertiliser) accrues fertiliser losses of between 10 to 15%. Blanket fertiliser application can increase runoff into waterways which causes accelerated eutrophication (Hart, *et al.*, 2004). The essential three components for differential fertiliser application to occur are; the temporal longevity of spatial soil fertility variations, the varying fertiliser additions must be based on pasture response trials or modelling, and models must be based on quantitative scientific trials results (Gillingham, *et al.*, (1991, 2001). Differential fertiliser application can increase a low P status hill country farm's stocking rate by 0.5 su/ha, and improve its economic return by 7.5%.

# Chapter 3

## Physical Environment,

## Experimental Design, and Field

## Sampling and Laboratory Methods

### **3.1 Introduction**

Chapter three contains the description of Blue Duck Station's climate, geology, and soils. An explanation of the experimental design and sampling regime, and the laboratory techniques used for soil chemical analysis are also included.

### **3.2 Physical environment**

#### **3.2.1 Location**

Blue duck station is a dry stock, sheep and beef hill-country farm located in the central King Country (Figure 1.1).

#### **3.2.2 Climate**

The King Country has a mean winter (July) temperature of 7.5°C, and an average summer (January) temperature of 18.3°C. Frost occurs, on average 62 days of the year. The King Countries sunshine hours are 1,629, lower than New Zealand's 1,800 average sunshine hours (Pollock, 2011). High cloud cover and an inland sheltered location means that the King Country receives as little as 40% of possible sunshine hours (Abel, *et al.*, 1978).



Precipitation is controlled by the King Country's hilly topography and has a yearly rainfall of between 1525 and 1775mm. My study site at Blue Duck Station is located in the Taumarunui-Te Kuiti corridor rain belt, which receives orographic rainfall due to the Western hills (Abel, *et al.*, 1978).

### 3.2.3 Parent material

The four main geological regions that can be distinguished within the King Country are (Abel, *et al.*, 1978):

1. Basalt zone in the south-east and north-west, from Tongariro-Ruapehu and Pirongia.
2. Ignimbrite flow covering the north-east quadrant of the region, which encompasses islands of greywacke.
3. Greywacke ranges that underlie the ignimbrite covering the northern half of the region.
4. Young, deeply dissected regions of soft sediments from Mokau to Ruapehu, which are mostly siltstones and silty-sandstone, creating plateau's and broad ridges. The broken hilly landscape has been formed due to the siltstones and silty-sandstones soft, easily erodible material.

The soils at Blue Duck Station are formed mainly on tephra and sedimentary rocks. The sedimentary rock is of Miocene origin (24 Ma) and mainly fine-grained sandstone and mudstone. The sediments deposited in the Miocene were eroded from calcareous sandstone, mudstone, and limestone that were deposited in Oligocene times (34-24 Ma). Tephra deposits are from both rhyolitic and andesitic volcanoes, forming a sequence of thin, fine-grained interfingering tephra layers (Lowe, 2010). Soil type and landscape variation are predominantly a reflection of the underlying rock type. The overlain tephra are deposited on the flat ridge tops, and accumulated on the valley floors via erosion. Large-scale mass movements are common on the steep slopes which are made up of Mahoenui Group mudstones (Edbrooke, 2005).

### 3.2.4 Soil

Ridge tops are mantled with tephra, the hill-slopes are mainly sedimentary, and valley floors consist of a mixture of both sedimentary and tephra derived colluvium and alluvium, creating a mosaic of soil types. Blue Duck Station's main soil types are; Typic Orthic Allophanic Soils (Ngaroma - Tapuwae soils), Acidic Orthic Brown Soils (Whangamomona - Maturangi soils) and Typic Orthic Recent Soils (Orbell, 1974).

#### *a) Allophanic Soils (Ngaroma - Tapuwae soils)*

Typic Orthic Allophanic Soils contain Allophane, Imogolite and Ferrihydrite minerals, which are products of weathered tephra material. Allophanic Soils are easily dug, feel greasy when moist, and samples are easily crumbled. Typic Orthic Allophanic Soils are permeable without barriers to deeply penetrating roots (Hewitt, 1998) (Landcare Research, 2012).

#### *b) Brown soil (Whangamomona - Maturangi soils)*

Brown Soils make up 43% of New Zealand and occupy the rolling and hilly lands of the southern King Country. Areas where Brown soils are common do not often experience summer drought or winter waterlogging, and are moderately to imperfectly drained (Hewitt, 1998, Landcare Research, 2012). Brown Soils are predominately formed in weathered sedimentary material (Orbell, 1974) where any tephra deposits have been removed by erosion. Subsoil is of brown or yellow brown colour due to weathered iron oxide from the parent material, and top-soil is dark grey-brown.

#### *c) Typic Orthic Recent Soils*

Recent soils show limited signs of soil-forming processes due to weak development. The A horizon is distinct, but lacks a developed B horizon (Landcare Research, 2012).

### 3.2.5 Land-use capability

The land-use capability system (LUC) is a rating of an area's ability to sustain agricultural production (Lynn, *et al.*, 2009). The LUC is a combination of The New

Zealand Land Resource Inventory, which records the five physical factors; rock type, soil, slope, present type and severity of erosion, and vegetation, and the LUC classification numbering system of eight classes, based on decreasing versatility and capability.

Blue Duck Station had 5 main LUC ratings (Lynn, *et al.*, 2009);

- Class III erosion limited – 0-7° slope. This class has slight erosion potential, and is mainly used for pasture on undulating country, with moderate limitations to arable use. located on the flat areas of both high and low elevation
  
- Class IV wetness limited - 0-7° slope. – This class is well suited to pastoral use; however, there is severe arable limitation due to wetness. Class IV wetness is located at the foot of some low slopes.
  
- Class IV erosion limited – 7-15° slope.–This class has nil to moderate sheet erosion, and is well suited to pastoral land, however, there is severe arable limitation due to erosion. This class is located on the majority of medium slopes.
  
- Class VI erosion limited – 21-25° Slope. This class has potential slight soil slip, earth flow and sheet erosion. Class VI is characteristic of relatively stable, good, North Island hill country which is non-arable due to erosion limitations. This class is limited to grazing pastures, and located in a small southern part of the farm.
  
- Class VII erosion limited – >25° Slope .This class has slight to severe soil slip, sheet and earth slow potential, only able to support extensive grazing or erosion control forestry. This class is located on the top eastern areas of the farm and bottom western corner.

### 3.3 *Experimental design*

#### 3.3.1 Experiment overview

GIS was used to delineate Blue Duck station into 6 landscape groups with similar aspect, slope and elevation.

##### *a) Digital elevation model*

Aspect, elevation and slope were created using a digital model of Blue Duck Station's terrain. The DEM was sourced from the University of Waikato Geography Department, and was to an accuracy of 25m (Figure 3.1).

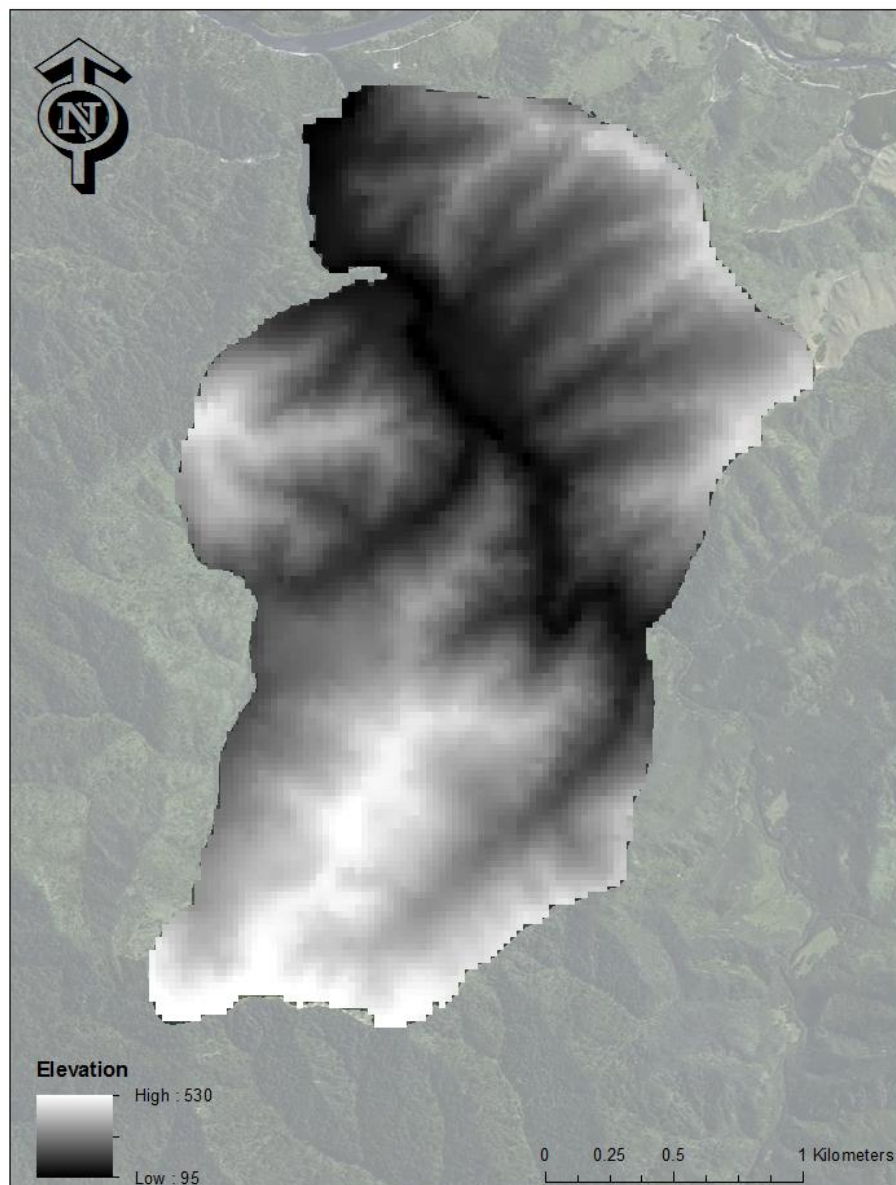

**Figure 3.1** Digital elevation model of Blue Duck Station

b) Slope

Blue Duck Station's effective farm land was split into 3 slope classes; low slope (1-12 °), medium slope (13-25 °) and steep slope ( $\geq 26$  °) (Figure 3.2). The slope classes used were adopted from a nutrient transfer model, created by Saggar *et al.* (1990).

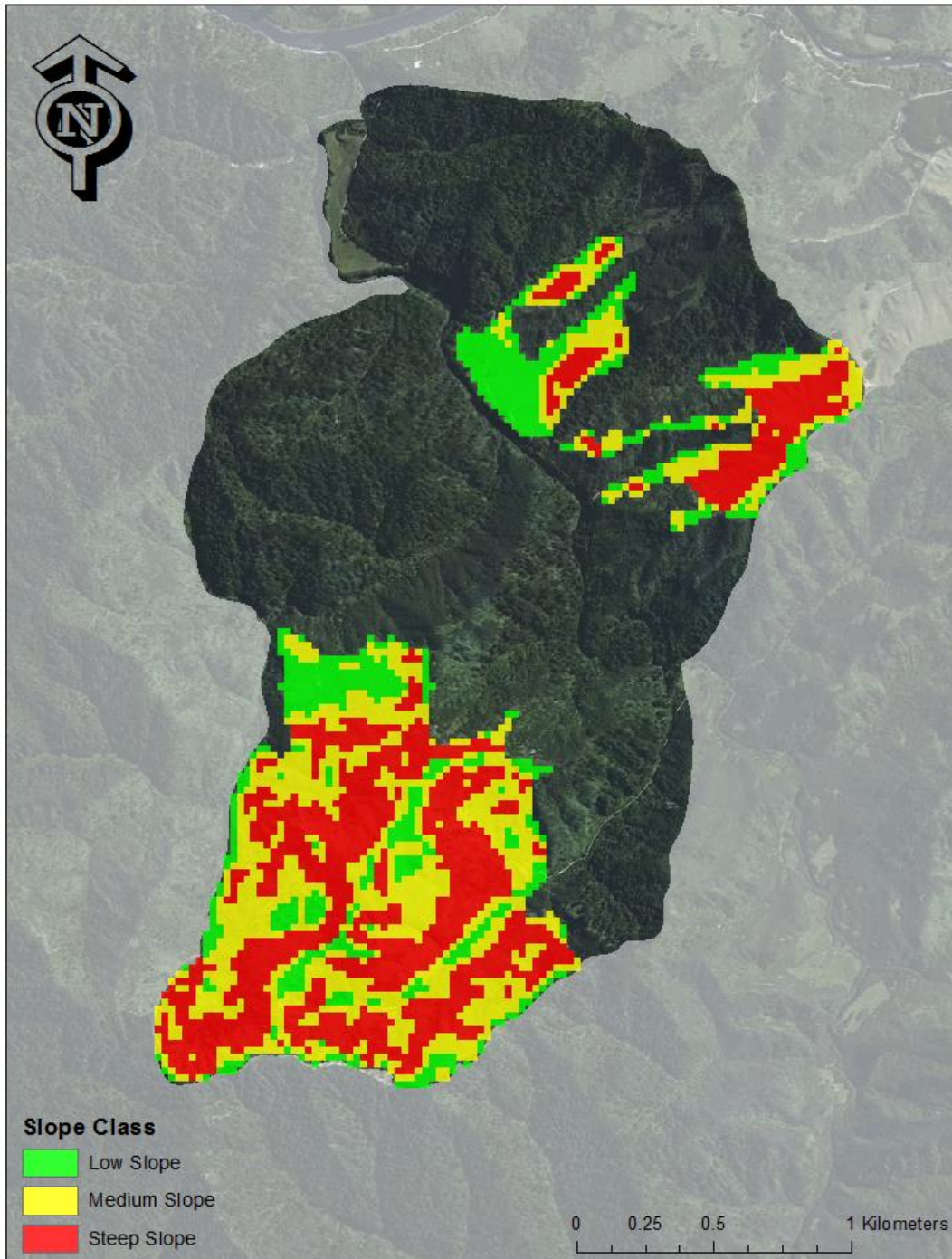
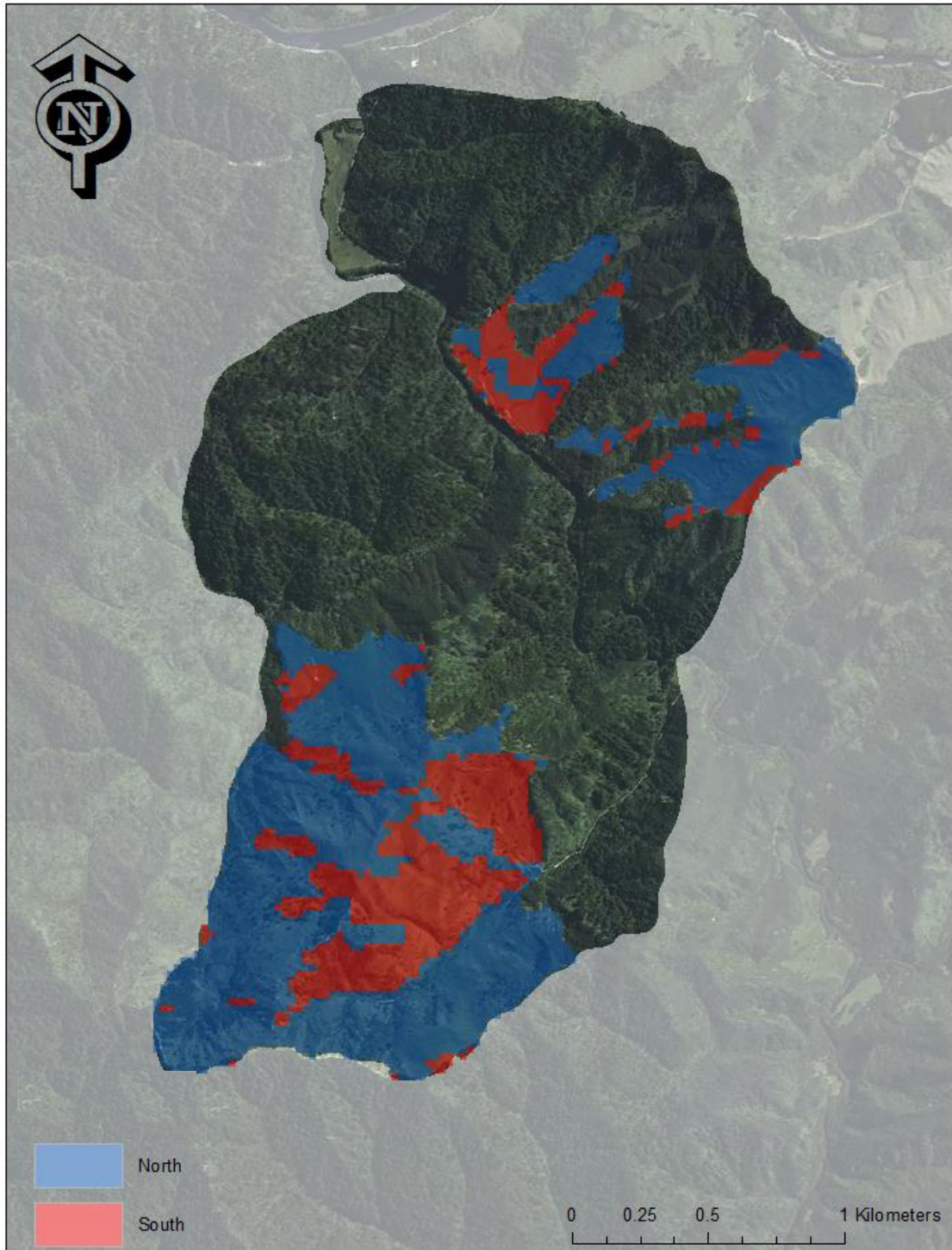

Figure 3.2 Slope model of Blue Duck Station



c) Aspect

Aspect classes were; North, 270 – 90 ° and South, 90 – 270 ° (Figure 3.3).



**Figure 3.3** Slope model of Blue Duck Station

d) Determination of landscape units

The 6 landscape groups created were; north facing medium slopes (NM) (13-25°); south facing medium slopes (SM) (13-25°); north facing steep slopes (NS) (>25); south facing steep slopes (SS) (>25), flat ridge tops (RL) (1-12° > 400 m elevation) and valley floors (VL) (1-12° < 150 m elevation)(Figure 3.4).

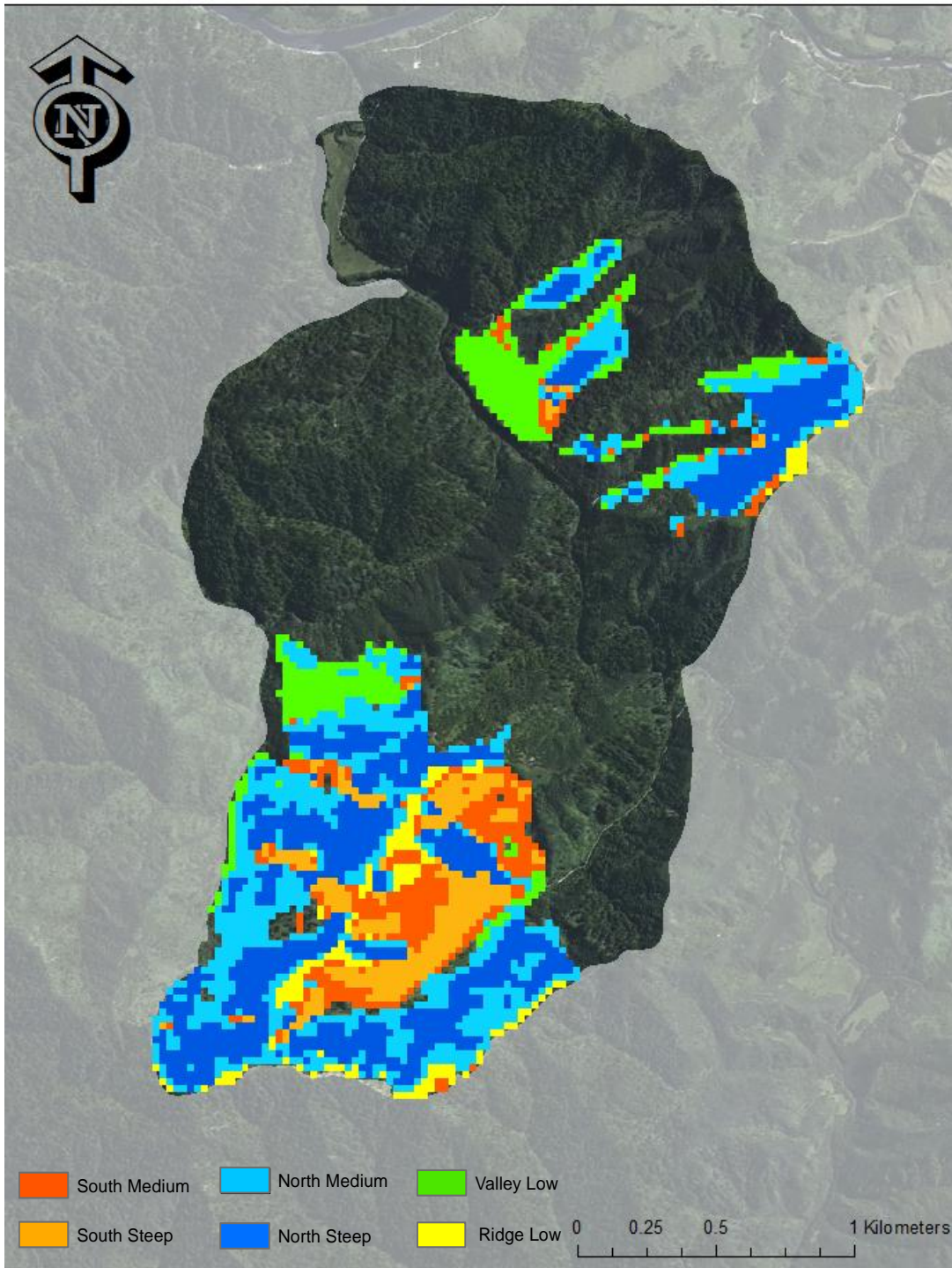

Figure 3.4 Landscape groups of Blue Duck Station



e) Study site locations

The location of samples sites once the 3 replicates from each landscape groups had been randomly selected (Figure 3.5).

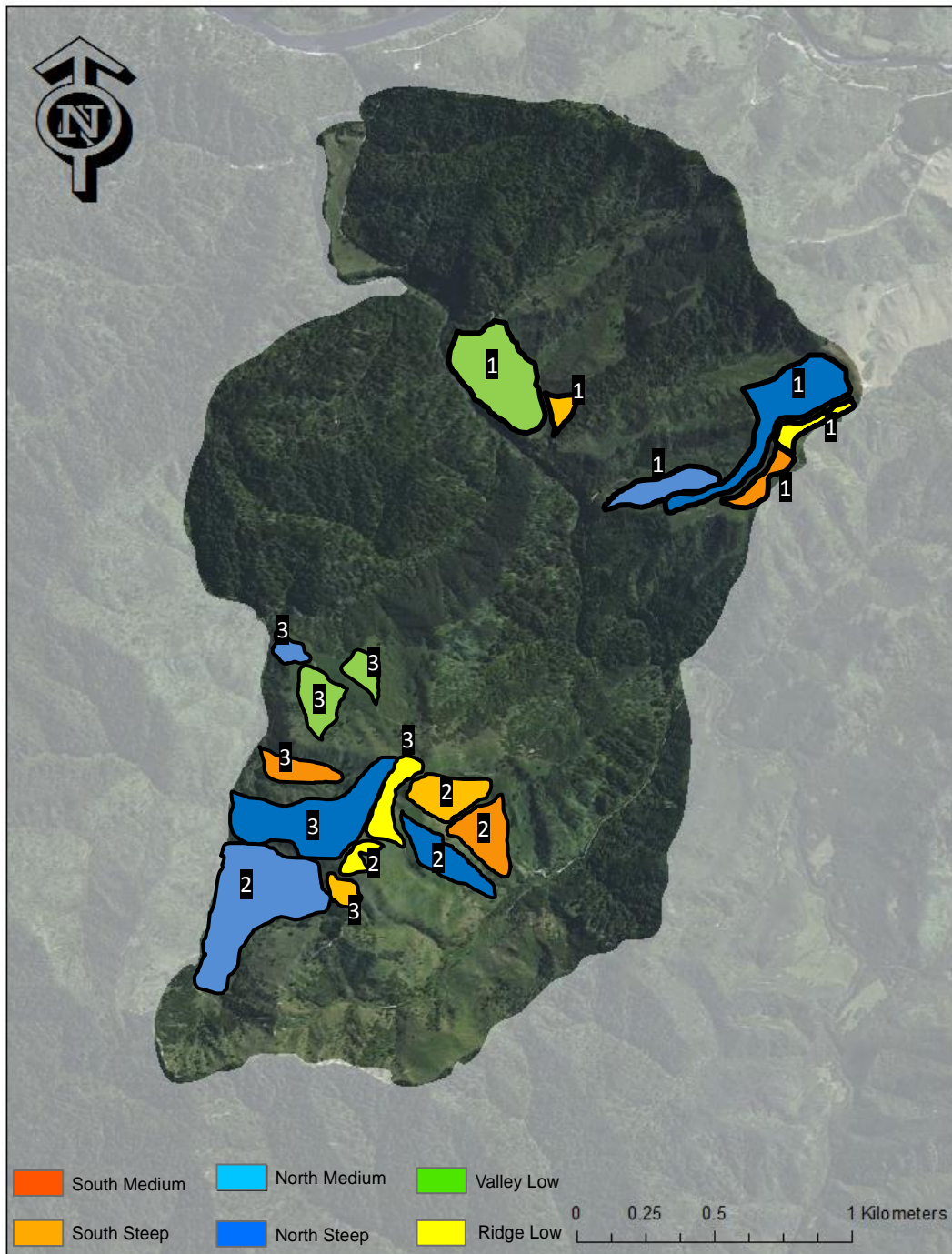

Figure 3.5 Study site locations. Numbers represent landscape group replicate



## 3.4 Experimental Design

### 3.4.1 Selecting and locating study sites

An important aspect of field sampling was randomisation and the elimination of sample bias, allowing for robust and representative data collection and results.

Three replicates for each of the 6 landscape groups were selected to be sampled, one replicate of each landscape group was randomly selected from the northern end of the farm and two replicates of each landscape group were randomly selected from the southern end of the farm. Randomisation was achieved by labelling each landscape unit with a number. A random number generator was then used to select 18 study sites, 3 from north facing steep slopes, 3 from north facing medium slopes, 3 from south facing steep slopes, 3 from south facing medium slopes, 3 from valley low slopes, and 3 from ridge low slopes.

The sample location of each landscape unit was determined by identifying the centre of mass of each polygon which was located using the “centroid” (geometric centre of a polygon) function of ARC GIS. The GPS co-ordinates of selected sample sites were then recorded and input into a hand-held GPS device, enabling the sample site to be located in the field.

### 3.4.2 Transect location and Sample Collection

Sampling was undertaken in summer between the 24<sup>th</sup> of February and the 1<sup>st</sup> of March, 2012 (Figure 3.6). The sampling was comprised of one transect sample and 5 grid samples at each sampling site. The transect sites began from the centre of mass within each landscape unit and extended in a random compass direction, unless the site was atypical. An atypical transect was any site with the presence of obstacles, such as landslip scars, trough sites, gate sites, farm tracks or fences, in which case, the transect was moved across in 5m intervals until at least 10m clear of obstacles. If irregularities, such as obvious urine or dung patches were encountered, sample core sites were moved so they were 50 cm clear of the irregularity.

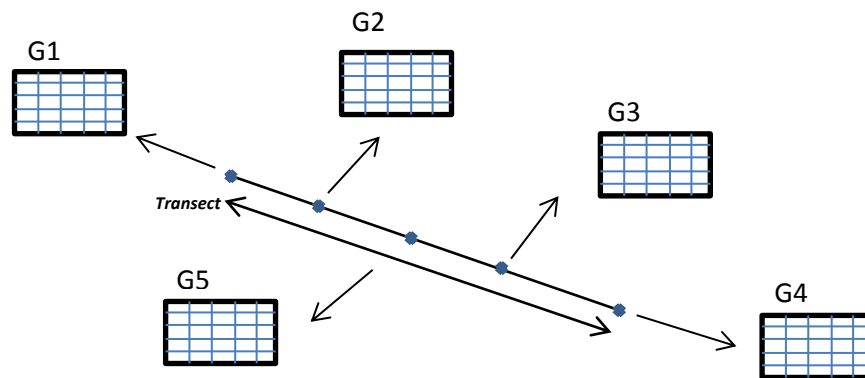

**Figure 3.6** Sample layout of sampling pattern. Transect and grids

The key attributes of each sample site were measured; latitude and longitude (GPS), altitude (GPS), slope (Abney level), aspect (compass), presence of animal dung, stock present and pasture quality. The transect line was stretched over 40 m (Figure 3.7 a). A topsoil description (3.7 b) at the beginning and end of each transect, was achieved by digging a 40cm soil pit (Figure 3.7 c). Every 2 m along the 40 m transect a soil sample was taken and bulked (Figure 3.7de) using a stainless steel push sampler, to a depth of 75 mm and a diameter of 25 mm (Figure 3.7 e). A grid sample 4 m x 5 m was taken 10m perpendicular to the transect every 5 metres (Figure 3.7 f). Six bulked soil samples were acquired on each landscape unit (Figure 3.7 d).



**Figures 3.7** - Summary of sample process - **a** - Laying out 40 m transect with 2 m interval - **b** - Soil profile to allow for profile description - **c** - Digging soil pits at each end of the transect - **d** - Bulking the samples at the end of the transect - **e** - Taking samples every two metres over the 40 m transect - **f** - Pacing out 10 m to sample the grid

### 3.4.3 Sample Labelling system

Each sample bag was pre-labelled with its landscape unit name, replicate number and sample number (Figure 3.8). A summary of all sample names used is in Table 3.1.

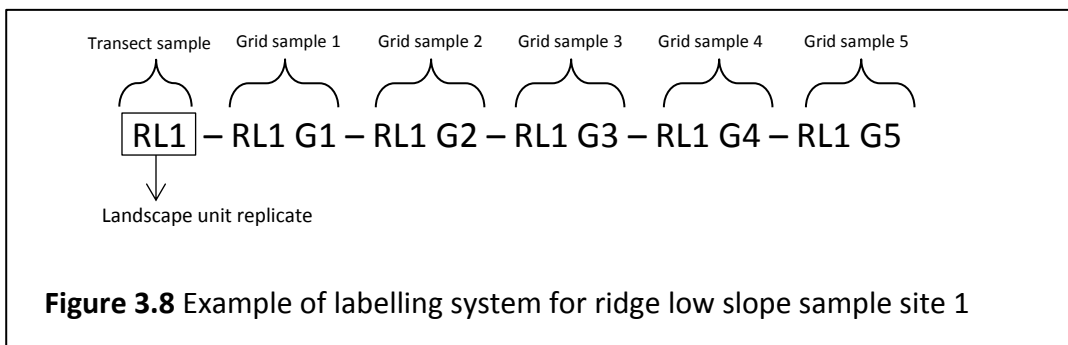

**Table 3.1** Summary of sample names

Landscape group	Transect sample name	Grid sample name
Ridge Low Slope 1	<b>RL 1</b>	RL1 G1 – RL1 G2 – RL1 G3 – RL1 G4 – RL1 G5
Ridge Low Slope 2	<b>RL 2</b>	RL2 G1 – RL2 G2 – RL2 G3 – RL2 G4 – RL2 G5
Ridge Low Slope 3	<b>RL 3</b>	RL3 G1 – RL3 G2 – RL3 G3 – RL3 G4 – RL3 G5
Valley Low Slope 1	<b>VL 1</b>	VL1 G1 – VL1 G2 – VL1 G3 – VL1 G4 – VL1 G5
Valley Low Slope 2	<b>VL 2</b>	VL2 G1 – VL2 G2 – VL2 G3 – VL2 G4 – VL2 G5
Valley Low Slope 3	<b>VL 3</b>	VL3 G1 – VL3 G2 – VL3 G3 – VL3 G4 – VL3 G5
South Facing Steep Slope 1	<b>SS 1</b>	SS1 G1 – SS1 G2 – SS1 G3 – SS1 G4 – SS1 G5
South Facing Steep Slope 2	<b>SS 2</b>	SS2 G1 – SS2 G2 – SS2 G3 – SS2 G4 – SS2 G5
South Facing Steep Slope 3	<b>SS 3</b>	SS3 G1 – SS3 G2 – SS3 G3 – SS3 G4 – SS3 G5
South Facing Medium Slope 1	<b>SM 1</b>	SM1 G1 – SM1 G2 – SM1 G3 – SM1 G4 – SM1 G5
South Facing Medium Slope 2	<b>SM 2</b>	SM2 G1 – SM2 G2 – SM2 G3 – SM2 G4 – SM2 G5
South Facing Medium Slope 3	<b>SM 3</b>	SM3 G1 – SM3 G2 – SM3 G3 – SM3 G4 – SM3 G5
North Facing Steep Slope 1	<b>NS 1</b>	NS1 G1 – NS1 G2 – NS1 G3 – NS1 G4 – NS1 G5
North Facing Steep Slope 2	<b>NS 2</b>	NS2 G1 – NS2 G2 – NS2 G3 – NS2 G4 – NS2 G5
North Facing Steep Slope 3	<b>NS 3</b>	NS3 G1 – NS3 G2 – NS3 G3 – NS3 G4 – NS3 G5
North Facing Medium Slope 1	<b>NM 1</b>	NM1 G1 – NM1 G2 – NM1 G3 – NM1 G4 – NM1 G5
North Facing Medium Slope 2	<b>NM 2</b>	NM2 G1 – NM2 G2 – NM2 G3 – NM2 G4 – NM2 G5
North Facing Medium Slope 3	<b>NM 3</b>	NM3 G1 – NM3 G2 – NM3 G3 – NM3 G4 – NM3 G5

### **3.5 Field Sampling – Native bush areas**

In addition to pastoral sampling, native bush samples were taken on both virgin, unaltered vegetation, and on area of vegetation that has been deforested for pastoral use, but allowed to regenerate back to native vegetation. All samples were taken on south facing medium slopes, to allow for a comparison with pastoral south facing medium sites.

The sampling regime within native vegetation consisted of 10 sample sites. Five sample sites were on a native vegetation site that had never been cleared for pastoral use, whilst the remaining five samples were taken from an area of native vegetation that had once been cleared and used for pastoral farming, but is now being left to regenerate. The method of sampling for native bush was similar to that of pastoral sampling, except that only a single transect was used and no grids were sampled. The attributes of the sample location were recorded, and every 2 m along the 40 m transect a soil sample was taken using a stainless steel push sampler, to a depth of 75 mm and a diameter of 25 mm. Each soil sample consisted of 20 bulked cores.

In the areas of regenerating native vegetation, occasional patches of cow dung were seen on stock trails which are evidence that there had been some stock movement. Stock trails were avoided for the purpose of sampling.

After discussion with the farmer on the most appropriate location to sample, a random sampling point was picked by walking 200 m in a random compass direction (random number generation) from the point of entry. Once the initial sample location was found for both the virgin and secondary vegetation sites, the subsequent 4 sample locations were taken 200 m from where the last transect ended.

## 3.6 **Laboratory Methods**

### 3.6.1 Introduction

Eurofins Labs analysed soil samples for Olsen P, anion storage capacity, pH, organic sulphur, sulphate-sulphur, calcium, potassium, magnesium and sodium. A separate analysis of soil pH was undertaken at the University of Waikato, Soil and Ecosystems Laboratory. The process of sample preparation and analysis are covered in this section. Methods for soil analysis (unless otherwise stated) were provided by Eurofins laboratory.

### 3.6.2 Sample Preparation

After samples were collected, I stored them in aluminium trays to begin air drying for three weeks. Samples were then sieved to 2 mm. Once sieved, I placed the samples in an oven at 35 °C for 21 hours to complete air drying. Samples were stored in air tight, sealed, labelled polythene bags to await analysis.

## 3.7 **Soil pH (Method undertaken and supplied by Eurofins Labs)**

Manual determination of soil pH was determined through a water slurry and left to stand for 16-24 hours (Eurofins Labs after, Blackmore, *et al.*, (1987), Cornforth, (1980); Lee, *et al.*, (1991)).

### 3.7.1 Reagent

a) *Potassium Chloride (3 M):*

b) *Hydrochloric Acid Cleaning Solution (0.1 M):*

Diluted 17.5 mL of HCl to 2 L with water.

c) *pH Electrode Storage Solution:*

Dissolved 1 g KCl in pH 7.00 buffer solution and made up to 200 mL in a volumetric flask with the buffer.

### 3.7.2 Standards

- a) Stock pH 4.00 Buffer  $\pm 0.02$ :
- b) Stock pH 7.00 Buffer  $\pm 0.02$ :

### 3.7.3 SAMPLE PREPARATION

Placed  $14 \pm 0.5$  mL of soil samples into beakers and added  $29.0 \pm 0.5$  mL of water. Samples were covered to avoid evaporation and left for 16-24 hours in a constant temperature room ( $20^{\circ}\text{C}$ ).

### 3.7.4 ANALYSIS

The pH meter was calibrated using pH 7.00 and pH 4.00 buffers until the slope displays between 97% and 100%. Soil samples were then thoroughly mixed, the pH electrode was inserted and the sample blasted with a compressed air jet inserted into the bottom of the soil slurry for 20 seconds, the samples were then allowed to settle to maximum depth. The pH measurement was recorded when pH meter beeped and calibration was checked after each batch of 40 samples. A maximum pH fluctuation of  $\pm 0.02$  was allowed before recalibration was necessary

### 3.8 **AMMONIUM ACETATE EXTRACTABLE CATIONS**

#### ***(Method undertaken and supplied by Eurofins Labs)***

Ammonium acetate soil extracts are analysed for the cations (Ca, K, Mg, Na) by an automated 4-channel flame spectrophotometer (Eurofins Labs after, Cornforth, (1980); Lee, *et al.*, (1991), Clinton, (1967)).

#### 3.8.1 Apparatus

- Reciprocating shaker.
- Atomic absorption/emission spectrophotometer (air/C<sub>2</sub>H<sub>2</sub>).
- AIM 1250 Autosampler.

#### 3.8.2 Reagents

##### a) *Extractant (1 M Ammonium Acetate):*

- 14158 g of 98% CH<sub>3</sub>COONH<sub>4</sub> was weighed out and transferred to a vat. Fill vat to 180 L mark with water.
- Mixture was stirred thoroughly and left overnight
- pH was checked = 7.00 ± 0.01
- If pH needed adjustment, ammonium solution (25%) or acetic acid was used.

#### 3.8.3 Standards

##### a) *Stock Standards:*

###### (i) 1000 µg/mL Mg:

- Magnesium Nitrate Spectrosol Atomic Absorption Standard.

###### (ii) 40000 µg/mL Ca:

- Calcium Chloride Volumetric Solution.

###### (iii) 5000 µg/ml Ca:

- 6.2431g CaCO<sub>3</sub> (oven dried 3hrs, 105°C) was weighed into a 500mL volumetric flask, 200mL water, and 20mL concentrated Hydrochloric acid was added and diluted to 500mL mark with water.



(iv) 1000 µg/ml Na:

- Sodium Nitrate Spectrosol Atomic Absorption Standard.

(v) 1600 µg/ml K:

- 3.051 g KCl (oven dried for 3 hours at 105°C) was dissolved in a 1000mL volumetric flask with water.

b) Working standards

Stock standard amounts (ml) in Table 3.2 were pipetted into a series of 100mL volumetric flasks and made to volume with the extractant.

**Table 3.2** Stock standard amounts (ml)

Standard	Mg (mL)	Ca (mL)	Na (mL)	K (mL)
Blank	0	0	0	0
Low	10	25	10	25
Middle	25	50	25	50
High	50	100	50	75

The cation concentration of the standards in µg/mL and Quick Test Units are shown in Table 3.3

**Table 3.3** Cation concentration in standards, and the corresponding concentrations in the soil in Quick Test Units (QTU)

Standards	Mg		Ca		Na		K	
	µg/mL in solution	QTU in solution	µg/mL in solution	QTU in solution	µg/mL in solution	QTU in solution	µg/mL in solution	QTU in solution
Blank	0	0	0	0	0	0	0	0
Low	10	10	125	5	10	10	40	10
Middle	25	25	250	10	25	25	80	20
High	50	50	500	20	50	50	120	30

#### 3.8.4 Sample Preparation

The soil sample (4.4 mL) was placed into 50mL conical flasks and  $20.0 \pm 0.2$  mL of extractant was added from the dispenser. The lids were placed onto the flasks and shaken for 2 minutes  $\pm$  5 seconds on the reciprocating shaker. Immediately after shaking, the extractants were filtered through 5B filter papers into 10 mL sample tubes. Sample were then placed onto a sample rack and loaded onto the auto-sampler, with the standards positioned from 1 to 6 in the standard rack.

#### 3.8.5 Analysis

Samples were analysed through a spectrometer, with a minimum wavelength reading of around 285 nm.

#### 3.8.6 Dilutions

Samples with concentrations greater than the top standard were diluted 6 times in a sample tube ie. 1 mL sample + 5 mL extractant. A note was made, and the computer analysing the sample made adjustments.

#### 3.8.7 Calculations

The raw spectrometer signal was processed through an analogue to digital converter, feeding data into the labs software application, which automatically calculating the cation level of each sample

### 3.9 ***OLSEN PHOSPHATE (Method undertaken and supplied by Eurofins Labs)***

Extracting the soil with 0.5 M sodium bicarbonate solution at pH 8.5. The orthophosphate ion ( $\text{PO}_4^-$ ) reacts with ammonium molybdate and antimony potassium tartrate under acidic conditions to form a yellow complex. This complex is reduced with ascorbic acid to form the characteristic blue colour, which absorbs at 880nm. The absorbance is proportional to the concentration of orthophosphate in the sample. (Eurofins Labs after, Olsen, *et al.*, (1954), Murphy & Riley, (1962), Watanabe & Olsen, (1965)).

#### 3.9.1 Apparatus

- Temperature controlled end-over-end shaker.
- Temperature controlled extractant vat.
- Lachat Flow Injection Analyser

#### 3.9.2 Extractant Reagents

##### a) *Sodium Hydroxide (4 M):*

A 2 L beaker filled with 1.5 L of water was placed in the fume cupboard in a tray containing cooling water, which then had 320 g of NaOH pellets added, a few at a time dissolved, then left to cool completely. The solution was transferred to a 2000mL volumetric flask and made to volume with water, mixed, and transferred to a labelled plastic container.

##### b) *Polyacrylamide Solution:*

A 2L beaker was filled with 1500 mL of water and boiled, in which 1.0 g of polyacrylamide was then added, and stirred until dissolved. Once completely cooled, it was transferred to a 2L volumetric flask and made to volume with water.

c) *Extractant (0.5M Sodium Bicarbonate, pH 8.50 ± 0.02, 25°C):*

For every litre required to make the vat to 100 L, 42 g of NaHCO<sub>3</sub>, 4.0 mL of 4 M NaOH and 5.0 mL of polyacrylamide solution was added. The remainder was made up to 100 L with water, and left overnight to stir with an automatic stirrer.

d) *pH 7.00 Buffer*

e) *pH 9.20 Buffer*

### 3.9.3 Flow Injection Reagent

a) *Reagent 1. Stock Ammonium Molybdate Solution:*

In a 1L volumetric flask, 40.0g of ammonium molybdate tetrahydrate [(NH<sub>4</sub>)<sub>6</sub>Mo<sub>7</sub>O<sub>24</sub>·4H<sub>2</sub>O] was dissolved, using approximately 800mL of deionised water. The mixture was then diluted to make 1 L and mixed with a magnetic stirrer for four hours.

b) *Reagent 2. Stock Antimony Potassium Tartrate Solution:*

In a 1L volumetric flask, 3.22g of antimony potassium tartrate (potassium antimony tartrate hemihydrate K(SbO)C<sub>2</sub>H<sub>4</sub>O<sub>6</sub>·1/2 H<sub>2</sub>O) was dissolved, using approximately 800mL of deionised water. Then diluted to 1L and mixed with a magnetic stirrer until dissolved.

c) *Reagent 3. Molybdate Colour Reagent:*

In a 1 L volumetric flask, 500mL of deionised water was added, to which 35.0mL of concentrated sulfuric acid (H<sub>2</sub>SO<sub>4</sub>) was added. Once cooled, 72mL of Antimony Potassium Tartrate Solution (Reagent 2) and 213mL Ammonium Molybdate Solution (Reagent 1) was added, then diluted to make 1 L, inverting to mix

d) *Reagent 4. Ascorbic Acid Reducing Solution:*

In a 1L volumetric flask, 60.0g of ascorbic acid was dissolved using approximately 800mL of deionised water. 2.0g of dodecyl sulfate (CH<sub>3</sub>(CH<sub>2</sub>)<sub>11</sub>OSO<sub>3</sub>Na) was then dissolved into the solution, which was then made to 1L with deionised water, mixed by inversion.

*e) Reagent 5. Sodium Hydroxide – EDTA Rinse:*

65g of sodium hydroxide (NaOH) and 6g of tetrasodium ethylenediamine tetraacetic acid (Na<sub>2</sub>EDTA) was dissolved in 1L of deionised water.

### 3.9.4 Standards

*a) Diluent (1 M Sodium Bicarbonate):*

In a 1000 mL beaker,  $84.00 \pm 0.01$  g of NaHCO<sub>3</sub> was dissolved into approximately 800 mL of water, with a magnetic stirrer. The pH was adjusted to  $8.50 \pm 0.02$  by adding 4 M NaOH to increase pH, or hydrochloric acid to decrease pH. The NaHCO<sub>3</sub> was transferred to a 1000 mL volumetric flask and made to volume with water.

*b) Stock Standard (500 ug/mL P):*

In a 250 mL volumetric flask,  $0.5490 \pm 0.001$  g of KH<sub>2</sub>PO<sub>4</sub> was dissolved with water. The KH<sub>2</sub>PO<sub>4</sub> was dried at 105°C for 3 hours before use.

*c) Secondary Standard (12.5 ug/mL P):*

In a 1000mL volumetric flask, 25 mL of stock standard was diluted with water..

*d) Working Standards:*

100 mL of the 1M NaHCO<sub>3</sub> solution was transferred to a series of 200 mL volumetric flasks. The 25 QTU standard was used as the check standard and made up to 500mL. 250 mL of the 1M NaHCO<sub>3</sub> solution was transferred to the 500 mL flask and the amounts of secondary standard in Table 3.4 were added to make to volume.

**Table 3.4** Amounts of secondary standard needed to make up to volume

Standard	Volume of Flasks (mL)	Volume of Secondary Standard (mL)	Concentrations	
			Solution ( $\mu\text{g/mL}$ )	Soil (QTU)
1	200	0	0	0
2	200	4.0	0.25	5
3	200	8.0	0.50	10
4	500	50.0	1.25	25
5	200	40.0	2.50	50
6	200	80.0	5.00	100
7	200	100.0	6.25	125

e) *Working Standards*

For each 1L required, 100 L milliQ solution, 5.0mL of polyacrylamide solution and 4.0 mL of 4 M NaOH was added.

3.9.5 Sample Preperation

The pH meter was calibrated at the buffer temperature using the pH 7.00 and pH 9.22 buffers. The extractant temperature was measured and pH meter was adjusted to this temperature. Each morning prior to use, the extractant was checked that it is at  $\text{pH } 8.50 \pm 0.02$ .

In a 250 ml Erlenmeyer flasks, 4 mL of soil and  $80 \pm 2$ mls of extractant was added into the flasks. Samples were shaken on an end over end shaker for 30 minutes at 25°C. Samples were then filtered through number 6 filter paper, into 10 mL test tubes, transferred to a test tube racks and placed onto an auto-sampler.

3.9.6 Analysis

A Lachat Flow Injection Analyser was used to analyse the samples for Olsen P

### **3.10 Potassium Phosphate Extractable Sulphate Sulphur (Method undertaken and supplied by Eurofins Labs)**

Potassium phosphate extracts are analysed for sulphate-sulphur by automated ion chromatography (Eurofins Labs after, Walkinson & Kear, (1994)).

#### **3.10.1 Extractant**

a) *0.02M Potassium Phosphate (monobasic) pH = 4.00 ± 0.02*

In a 10L aspirator, 27.2g of 0.02M Potassium Phosphate (monobasic) was dissolved in approximately 600mL of water overnight. Then made to 10L with water and the pH was adjusted to 4.00 ± 0.02, using 20% HCl or KOH solution.

#### **3.10.2 Sample Preparation**

In a 50mL conical flask, 4.00 ± 0.01g of soil and 20 ± 0.5 mL of extractant was added. The samples were then shaken for 30 ± 5 minutes on an end over end shaker and filtered through number 5C filter papers into test tubes immediately after shaking. If extracts were cloudy, they were re-filtered through a new filter paper until a clear filtrate was obtained. Once filtered, test tubes were transferred into the test tube rack and analysis on the Dionex ICS-2100 Ion Chromatography System (ICS-2100).

#### **3.10.3 Analysis using ICS-2100 ION CHROMATOGRAPH**

The ICS-2100 ION CHROMATOGRAPH was used to analyse the samples for sulphate sulphur

#### **3.10.4 Standards**

a) *Stock Standard (1000ug/mL S):*

Dissolve 4.4308g of Na<sub>2</sub>SO<sub>4</sub> (oven dried for 3 hours at 105°C) in a 1000 mL volumetric flask with Milli Q water.

b) *Secondary Standard (100ug/mL S):*

Dilute 100mL of the stock standard in a 1L volumetric flask with the extractant.

c) *Working Standards:*

Secondary standard were diluted with the extractant into a series of 500mL volumetric flasks, amount in Table 3.5.

**Table 3.5** Amounts of secondary standards to be diluted with the extractant

<i>Standard</i>	<i>Volume of Flasks (mL)</i>	<i>Concentration of sulphate sulphur in</i>	
		<i>Solution in (µg/mL)</i>	<i>Soil Sample in QTU</i>
<b>1</b>	5	1	0
<b>2</b>	15	3	0.25
<b>3</b>	50	10	0.50
<b>4</b>	150	30	1.25

### 3.10.5 Instrument QC Standards

a) *Stock 1500 (ug/mL S):*

Weighed 2.038g of dried K<sub>2</sub>SO<sub>4</sub> and diluted into 250mL flask.

b) *Sub Stock 75 (ug/mL S):*

Diluted 10mL of 1500 ug/mL Stock into a 200mL flask.

c) *Instrument QC Standard 15 QTU (3 ug/mL S):*

Diluted 20mL of 75 ug/mL Sub Stock with the extractant into 500mL

### 3.10.6 Analysis

The Chromeleon 7 was used to analyse the samples for sulphate sulphur



### 3.11 ***Potassium Phosphate Extractable Organic Sulphur (Method undertaken and supplied by Eurofins Labs)***

Potassium phosphate extracts analysed for sulphate-sulphur are then measured for total sulphur by ICP-OES and the difference calculated is reported as Organic Sulphur (Eurofins Labs after, Watkinson & Perrot, (1990), Watkinson & Kear, (1996), Watkinson & Kear, (1996))

#### 3.11.1 APPARATUS

- End over End Shaker.
- Apparatus TJA IRIS-AP ICP-OES or Perkin Elmer OPTIMA 2000 ICP - OES.

#### 3.11.2 EXTRACTION

a) *Extractant - 0.02M Potassium Phosphate (monobasic) pH = 4.00 ± 0.02:*

10L of extractant was made. In a 10L aspirator, 27.2g of 0.02M Potassium Phosphate was dissolved with approximately 600mL of water. 10mL of chloroform was added under fume hood and left to dissolve overnight, then made to 10L with water. The pH was adjusted to 4.00 ± 0.02 using 20% HCl or KOH solution.

#### 3.11.3 STANDARDS

a) *Stock Standard (1000ug/mL S):*

4.4308g of Na<sub>2</sub>SO<sub>4</sub> (oven dried for 3 hours at 105°C) in a 1000mL volumetric flask with Milli Q water.

a) *Secondary Standard (100ug/mL S):*

In a 1L volumetric flask, 100 ml of the stock standard was diluted with the extractant.

*b) Working Standards:*

Working standard were made by diluting secondary standard with extractant, to the levels shown in Table 3.6, into a series of 500mL volumetric flasks.

**Table 3.6** Amounts of secondary standards to be diluted with the extractant

<i>Standard</i>	<i>Volume of Flasks (mL)</i>	<i>Concentration of sulphate sulphur in</i>	
		<i>Solution in (<math>\mu\text{g/mL}</math>)</i>	<i>Soil Sample in QTU</i>
<b>1</b>	5	1	0
<b>2</b>	15	3	0.25
<b>3</b>	50	10	0.50
<b>4</b>	150	30	1.25

#### 3.11.4 INSTRUMENT QC STANDARD

*a) Stock 1500 (ug/mL S)*

Diluted 2.038g of dried K<sub>2</sub>SO<sub>4</sub> into a 250mL flask.

*c) Sub Stock 75 (ug/mL S)*

Diluted 10mL of 1500 ug/mL Stock into a 200mL flask.

*d) 3(ug/mL S) Instrument QC Standard:*

Diluted 20mL of 75 ug/mL Sub Stock with extractant into 500mL

#### 3.11.5 SAMPLE PREPARATION

Weighed  $4.00 \pm 0.01\text{g}$  of soil into a 50 mL conical flask and then dispensed  $20 \pm 0.5$  mL of extractant into each flask. The flasks were then shaken for  $30 \pm 5$  minutes with an end over end shaker. Extracts were then filtered through 5C filter paper into test tubes, immediately after shaking. If extracts were cloudy, they were re-filtered through a new filter paper until a clear filtrate was obtained. The samples were run on ICP-OES for Total sulphur. The same samples were then analysed for sulphate sulphur on HPIC (High Performance Ion Chromatography)

and the organic sulphur was measured by the difference between total sulphur and sulphate sulphur.

### 3.11.6 ANALYSIS

Soil S Method programme at Eurofins Lab was used for analysis and processed in LABMAN

## 3.12 ***Anion Storage Capacity (Method undertaken and supplied by Eurofins Labs)***

A 5 g soil sample is shaken with a buffered phosphate solution for 16 hours on an end-over-end shaker. A buffer pH of 4.6 is used to closely achieve the maximum phosphate retention in many soils. The amount of phosphate remaining in solution is determined calorimetrically using visible spectroscopy and from this the Anion Storage Capacity (phosphate retention) is calculated (Eurofins Labs after, Blackmore, *et al.*, (1987)).

### 3.12.1 APPARATUS

- End-over-end shaker.
- Gilson 401 Dilutor
- Shimadzu UV Mini 1240 Spectrophotometer

### 3.12.2 REAGENTS

#### a) *Buffer Solution (pH 4.6, 1000 µg/mL P):*

In a 10L aspirator, 43.94 g of  $\text{KH}_2\text{PO}_4$  and 136.0 g  $\text{CH}_3\text{COONa}\cdot 3\text{H}_2\text{O}$  was dissolved in 2 L of water, 57 mL of acetic acid was then added and then made to volume.

#### b) *Molybdo-vanadate Stock Reagent*

In two separate 600 ml portions of water, 40g of Ammonium Molybdate ( $(\text{NH}_4)_6\text{Mo}_7\text{O}_{24}\cdot 4\text{H}_2\text{O}$ ) and 2g of Ammonium Vanadate ( $\text{NH}_4\text{VO}_3$ ) were dissolved. They were then dissolved by heating and gently mixing (less than

60°C). The two solutions were mixed and 280 ml of concentrated Nitric Acid was added, then diluted to 2 litres and mixed well.

*c) Molybdo-vanadate Working Reagent*

Diluted stock vanadate reagent four times i.e. diluted 250ml of stock into 1000ml water.

### 3.12.3 STANDARDS

*a) Diluent (Sodium Acetate Trihydrate):*

In a 1000 mL volumetric flask, 13.60 g of CH<sub>3</sub>COONa.3H<sub>2</sub>O and 5.7 mL acetic acid were diluted and made to volume with water.

*b) Working Standards.*

Working standards were made up by adding varying amounts of P buffer solution (1000 g/mL) (Table 3.7) into a series of 100 mL volumetric flasks and made to volume with the diluent.

**Table 3.7** Working standard amounts

<i>Standard</i>	<i>Volume of P buffer solution added (mL)</i>	<i>Anion Storage Capacity</i>	
		<i>Solution in (µg/mL)</i>	<i>In soil (%)</i>
<b>1</b>	0	0	100
<b>2</b>	20	200	80
<b>3</b>	50	500	50
<b>4</b>	70	700	30
<b>5</b>	100	1000	0

### 3.12.4 SAMPLE PREPARATION

5.00 ± 0.01g of soil samples were weighed into 50 mL conical flasks, adding 25.0 ± 0.5 mL of the buffered P solution. Flasks were stoppered and shaken with an end-over-end shaker for 16 hours ± 15 minutes. Samples were filtered into test tubes through Advantec 131 fluted filter paper.

### 3.12.5 ANALYSIS

Calibrated Gilson 401 Dilutor was used to analysis the samples. 9 mLs of Molybdo-vanadate working reagent was added to 0.1 ml of sample and standards and placed into numbered test tubes, mixed well and left to colour up for at least 1 hour. A spectrophotometer was used to measure the colour.

## 3.13 *Soil pH analysis at Waikato University*

There are several complications and difficulties to be aware of when measuring soil pH. Using a pH electrode reflects the hydrogen activity in the bulk soil solution and not the total hydrogen ion activity around the soil particle. Soil pH provides useful links with other soil properties and allows for important soil management decisions (Thompson & Troeh, 1973).

Soil pH was measured following the method of Blakemore, *et al.*, (1987)

1. Acid wash and rinse 50 ml sample pots with deionised water
2. Weighed 10 g of soil and 25 ml of deionised water into each pot
3. Homogenised for 6 seconds on high speed
4. Left overnight to settle
5. Measured the pH using an Jenway 3510 pH meter. Checking the temperature of the solution each morning, and periodically throughout analysis to monitor and the meter was adjusted to the current temperature.

# Chapter 4

## Results

### **4.1 *Sample site description***

The combination of photographs at the beginning of this chapter helps illustrate the location of each study site within the landscape. A photo of the top soil, pasture composition, and overall site photo are displayed for each replicate of all landscape groups.

#### 4.1.1 Valley Low study unit one

Below are the main attributes of valley low, study site one; location, altitude, slope, soil class, vegetation, stock and other comment to be record present at site (Figure 4.1).



**Figure 4.1** Valley low site one, site data summary

**Location:** 157 ° 4' 2.8'' 39 ° 7' 24.746'' **Altitude:** 145m **Slope:** 4°

**Soil class:** Allophanic Soil

**Vegetation:** Moderate Scotch thistles with some clover and mixed grasses.

**Stock:** No stock at present, 25 steers one week previously.

**Other comments:** Flat, highly grazed area. The only flat area on the farm receiving lime fertiliser.



#### 4.1.2 Valley Low study unit two

Below are the main attributes of valley low, study site two; location, altitude, slope, soil class, vegetation, stock and other comment to be record present at site (Figure 4.2).



**Figure 4.2** Valley Low slope site two, site data summary

**Location:** 39 ° 07' 59.4 " 175° 03' 41.9 " **Altitude:** 283m **Slope:** 3°

**Soil class:** Allophanic Soil

**Vegetation:** Apparent rushes. Mixed grasses, some grass gone to seed.

**Stock:** Sheep (1200-1500) Cattle (100 steers).

**Other comments:** Flat from the beginning of the transect, then steepened off at the end of (4-5°). Not reached by the lime trucks, though similar in appearance to VL1.



#### 4.1.3 Valley Low study unit three

Below are the main attributes of valley low, study site three; location, altitude, slope, soil class, vegetation, stock and other comment to be record present at site (Figure 4.3).

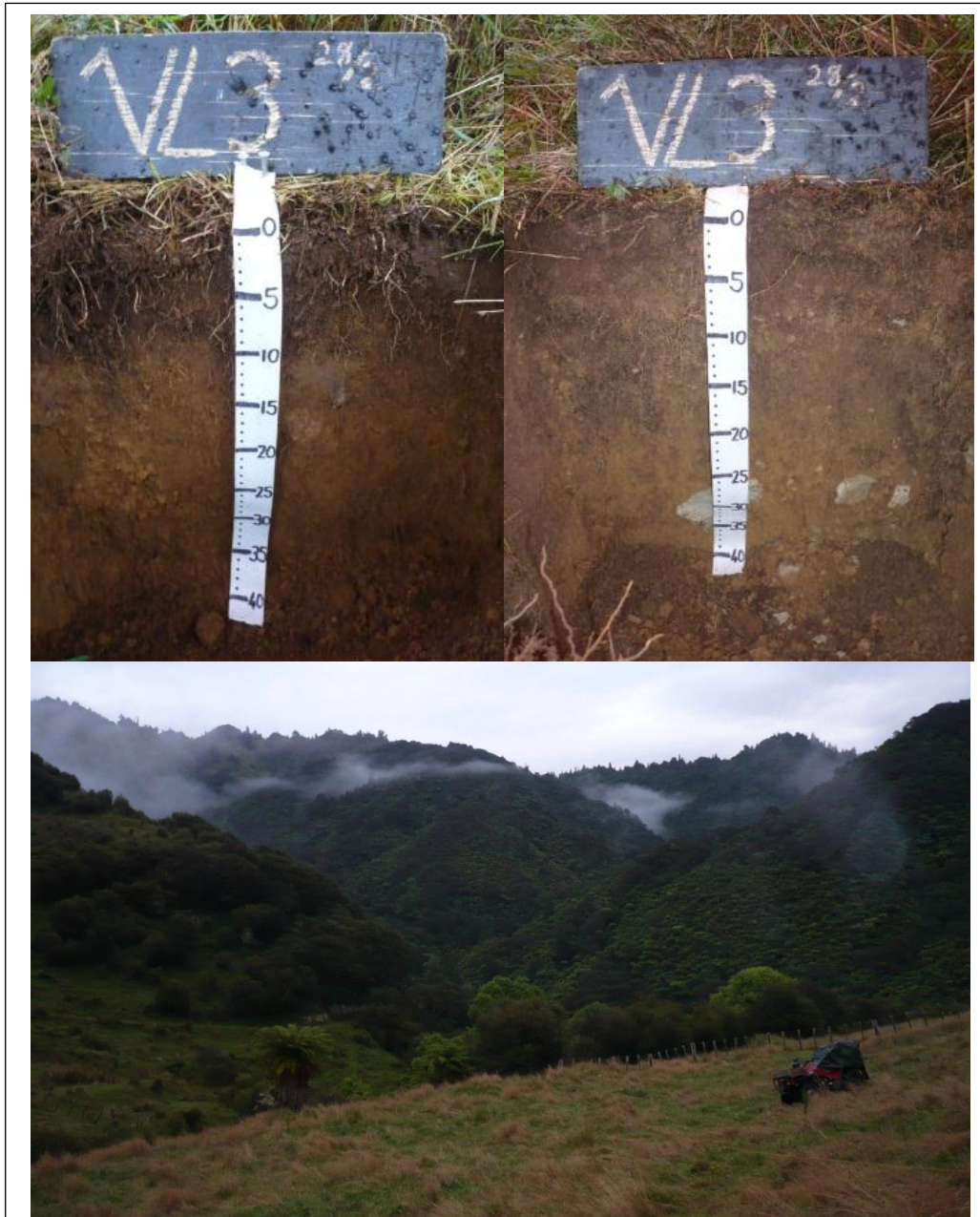

**Figure 4.3** Valley Low slope site three, site data summary

**Location:** 39° 08' 02.3 " 175° 03' 30.07 " **Altitude:** 249m **Slope:** 9°

**Soil class:** Allophanic Soil

**Vegetation:** Pasture has been noticeably grazed. Grass at a medium length (30cm), less grazing than VL1 or VL2.

**Stock:** Wild deer and goats seen grazing, no domestic stock at present.

**Other comments:** Small paddock in comparison to the rest of the farm. Potentially used as a holding paddock, and surrounded by historic Whare, old motorbike track and small creek.

#### 4.1.4 Ridge Low study unit one

Below are the main attributes of ridge low, study site one; location, altitude, slope, soil class, vegetation, stock and other comment to be record present at site (Figure 4.4).



**Figure 4.4** Ridge Low slope site one, site data summary

**Location:** 39 ° 07' 27.5 " 175 ° 04' 51.6 " **Altitude:** 428m **Slope:** 7°

**Soil class:** Brown Soil

**Vegetation:** For the most part grass has been well grazed, though some small patches of grass have gone to seed. High clover content and mixed grasses.

**Stock:** 1200 - 1500 sheep one week previously.

**Other comments:** High point on the farm, and what looks like an old fence line and track to the right. Narrow ridge, 50m wide. High winds, potential wind erosion.



#### 4.1.5 Ridge Low study unit two

Below are the main attributes of ridge low, study site two: location, altitude, slope, soil class, vegetation, stock and other comment to be record present at site (Figure 5.5).



**Figure 4.5** Ridge Low slope site two, site data summary

**Location:** 39° 08' 16.4" 175° 03' 49.3" **Altitude:** 463m **Slope:** 2°

**Soil class:** Allophanic Soil

**Vegetation:** High clover content and mixed grasses. Pasture has been well grazed.

**Stock:** Well grazed, 1200-1500 sheep.

#### 4.1.6 Ridge Low study unit three

Below are the main attributes of ridge low, study site three; location, altitude, slope, soil class, vegetation, stock and other comment to be record present at site (Figure 4.6).



**Figure 4.6** Ridge Low slope site three, site data summary

**Location:** 39 ° 08' 11.4 '' 175 ° 03' 49.5' **Altitude:** 459m **Slope:** 1°

**Soil class:** Brown Soil

**Vegetation:** Well grazed.

**Stock:** 1200-1500 sheep and 100 steers.

**Other comments:** A low slope, however, the top soil is shallower. Undulation is higher than other ridge low slopes. Steep faces both sides.



#### 4.1.7 North facing steep slope study unit one

Below are the main attributes of north facing steep slope, study site one; location, altitude, slope, soil class, vegetation, stock and other comment to be record present at site (Figure 4.7).



**Figure 4.7** North Facing steep slope site one, site data summary

**Location:** 39 ° 08' 11.4 " 175 ° 03' 49.5' **Altitude:** 361m **Slope:** 20° **Aspect:** 20°

**Soil class:** Recent Soils

**Vegetation:** Long patches of grass that have gone to seed. Noticeable grazing in some areas, between long grass patches.

**Stock:** No stock at present. 1200-1500 sheep one week previously. Feral goats grazing.

**Other comments:** Obvious sheep dung.

#### 4.1.8 North facing steep slope study unit two

Below are the main attributes of north facing steep slope, study site one; location, altitude, slope, soil class, vegetation, stock and other comment to be record present at site (Figure 4.8).



**Figure 4.8** North Facing steep slope site two, site data summary

**Location:** 39 ° 08' 09.6 '' 175 ° 03' 48.2 '' **Altitude:** 350m **Slope:** 36° **Aspect:** 65°

**Soil class:** Recent Soil

**Vegetation:** Mixed grass, predominant Browntop.

**Stock:** 1200-1500 sheep. Well grazed. Sheep grazing below, on the lower slopes.



#### 4.1.9 North facing steep slope study unit three

Below are the main attributes of north facing steep slope, study site two; location, altitude, slope, soil class, vegetation, stock and other comment to be record present at site (Figure 4.9).



**Figure 4.9** North Facing steep slope site three, site data summary

**Location:** 39 ° 08 ' 09.6 " 175 ° 03 ' 48.2 " **Altitude:** 431m **Slope:** 35° **Aspect:** 294°

**Soil class:** Brown soil

**Vegetation:** Some scattered ferns and bush. Grass gone to seed.

**Stock:** 1200-1500 sheep one week previous. 100 steers currently grazing.



#### 4.1.10 North Medium study unit one

Below are the main attributes of north medium steep slope, study site one; location, altitude, slope, soil class, vegetation, stock and other comment to be record present at site (Figure 4.10).



**Figure 4.10** North Facing medium slope site one, site data summary

**Location:** 39 ° 07 ' 21.5 " 175 ° 04 ' 40.2 " **Altitude:** 273m **Slope:** 15° **Aspect:** 15°

**Soil class:** Brown soil

**Vegetation:** Patches of rushes. Some grass gone to seed, but areas noticeable grazing

**Stock:** 1200-1500 sheep one week previous.

**Other comments:** A raised "micro" ridge around a wet area. Small creek to the left side of sample sites, bordering borders native bush.



#### 4.1.11 North Medium study unit two

Below are the main attributes of north facing medium slope, study site two; location, altitude, slope, soil class, vegetation, stock and other comment to be record present at site (Figure 4.11).



**Figure 4.11** North Facing medium slope site two, site data summary

**Location:** 39 ° 08 ' 25.7" 175 ° 03 ' 28.9" **Altitude:** 387m **Slope:** 11° **Aspect:** 300°

**Soil class:** Brown soil

**Vegetation:** Highly grazed, Scotch thistles, some patchy ferns. Poor pasture.

**Stocking:** Sheep present, 100 Steers, 30 cows.

#### 4.1.12 North Medium study unit 3

Below are the main attributes of north facing medium slope, study site three; location, altitude, slope, soil class, vegetation, stock and other comment to be record present at site (Figure 4.12).



**Figure 4.12** North Facing medium slope site three, site data summary

**Location:** 39 ° 07' 56.6'' 175° 03' 29.6'' **Altitude:** 260m **Slope:** 14° **Aspect:** 320°

**Soil class:** Brown soil

**Vegetation:** Long grass gone to seed.

**Stock:** Little noticeable grazing.



#### 4.1.13 South Steep study unit one

Below are the main attributes of south facing steep slope, study site one; location, altitude, slope, soil class, vegetation, stock and other comment to be record present at site (Figure 4.13).



#### 4.1.14 South Steep study unit two

Below are the main attributes of south facing steep slope, study site two; location, altitude, slope, soil class, vegetation, stock and other comment to be record present at site (Figure 4.14).





#### 4.1.15 South Steep study unit three

Below are the main attributes of south facing steep slope, study site three; location, altitude, slope, soil class, vegetation, stock and other comment to be record present at site (Figure 4.15).



#### 4.1.16 South Medium study unit one

Below are the main attributes of south facing medium slope, study site one; location, altitude, slope, soil class, vegetation, stock and other comment to be record present at site (Figure 4.16).



**Figure 4.16** South medium slope site one, site data summary

**Location:** 39° 07' 37.2" 175° 04' 38.6" **Altitude:** 391m **Slope:** 13.5° **Aspect:** 190°

**Soil class:** Allophanic Soil

**Vegetation:** Small valley dip.

**Stock:** 1200-1500 sheep one week previous. Obvious dung patches.

**Other comments:** SM1 G2 look like it could be a sheep camp site. Very windy.



#### 4.1.17 South Medium study unit two

Below are the main attributes of south facing medium slope, study site two; location, altitude, slope, soil class, vegetation, stock and other comment to be record present at site (Figure 4.17).



**Figure 4.17** South medium slope site two, site data summary

**Location:** 39 ° 08 ' 14.0 " 175 ° 04 ' 01.0 " **Altitude:** 341m **Slope:** 23° **Aspect:** 160°

**Soil class:** Brown soil

**Vegetation:** Noticeably grazed. Scotch thistles. Mixed grasses with limited clover

**Stock:** 2000-1500 sheep at present. Large amounts of sheep dung, due to potential sheep camp.

**Other comments:** Oddly deep topsoil. 'Micro' flat within medium slopes

#### 4.1.18 South Medium study *unit* three

Below are the main attributes of south facing medium slope, study site three; location, altitude, slope, soil class, vegetation, stock and other comment to be record present at site (Figure 4.18).



**Figure 4.18** South medium slope site three, site data summary

**Location:** 39° 08' 08.5" 175° 03' 31.7" **Altitude:** 127m **Slope:** 16° **Aspect:** 160°

**Soil class:** Brown soil

**Vegetation:** Some patches of grass gone to seed, but majority well grazed

**Stock:** No stock at present

**Other comments:** Marginal land. Scattered bush becoming dense. The side of a ridge sloping down to a track and creek. Very sheltered



## 4.2 Introduction of soil chemical property results

Chapter four present's results obtained from laboratory analysis of soils collected from Blue Duck Station. The Olsen P, anion storage capacity, pH, sulphate-sulphur and cation (Mg, Na, K, Ca) levels were determined for each sample. Measurements of soil chemical properties were made from air-dried soil samples. The relationship between, varying soil chemical properties and landscape groups, and variation within study site are investigated. Selected soil properties were plotted against Olsen P and ASC to investigate possible relationships.

### 4.2.1 Ratings of Soil Properties

The ratings and recommended ranges for soil chemical properties used in this thesis are given in Table 4.1.

**Table 4.1** New Zealand Soil Bureau soil chemical properties ratings (after Blakemore, et al., 1987). Organic sulphur rating and optimal cation levels (MAF QT) under pastoral agriculture (after Hill Laboratories, 2012c)

<b>Rating</b>	<b>pH<sup>1</sup></b>	<b>Olsen P<sup>1</sup></b>	<b>ASC (%)<sup>1</sup></b>	<b>Sulphate-Sulphur (mg/kg)<sup>1</sup></b>	<b>Organic Sulphur (mg/kg)<sup>2</sup></b>
<b>Very Low</b>	<4.5	<10	0-10	<5	<5
<b>Low</b>	4.5-5.2	10-20	10-30	5-15	5-11
<b>Medium</b>	5.3-6	20-30	30-60	15-50	12-20
<b>High</b>	6-7.1	30-50	60-90	50-150	>20
<b>Very High</b>	>7.1	>50	90-100	> 150	-
<b>Optimal cation range</b>		<b>Potassium<sup>2</sup></b>	<b>Calcium<sup>2</sup></b>	<b>Magnesium<sup>2</sup></b>	<b>Sodium<sup>2</sup></b>
<b>MAF QT values</b>		10.4-16.64	7.74-15.48	23.3-69.9	10.6-26.5

2 Ratings from Hill Laboratories 2012c

1 Ratings from Blakemore, et al., 1987

### 4.3 Results of chemical analysis

#### 4.3.1 *Olsen P*

The Olsen P ranged from a mean of 6.8 in the south facing medium slopes through to a mean of 21.2 in the north facing medium slopes. North facing medium slopes and valley low slopes had higher mean Olsen P values than all other landscape groups ( $P < 0.01$ ) (Figure 4.19).

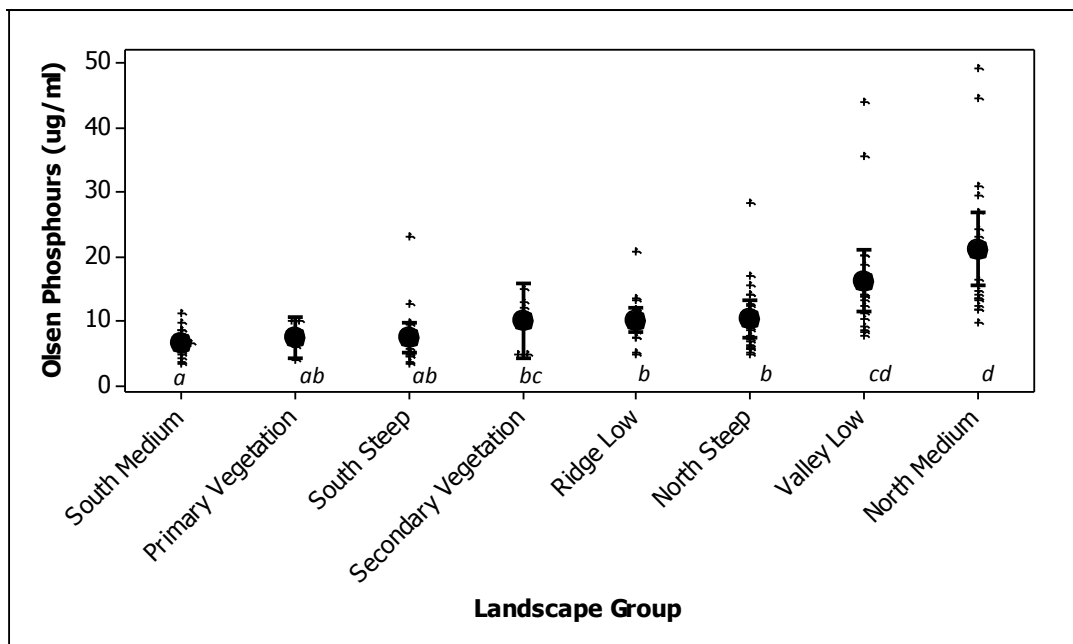
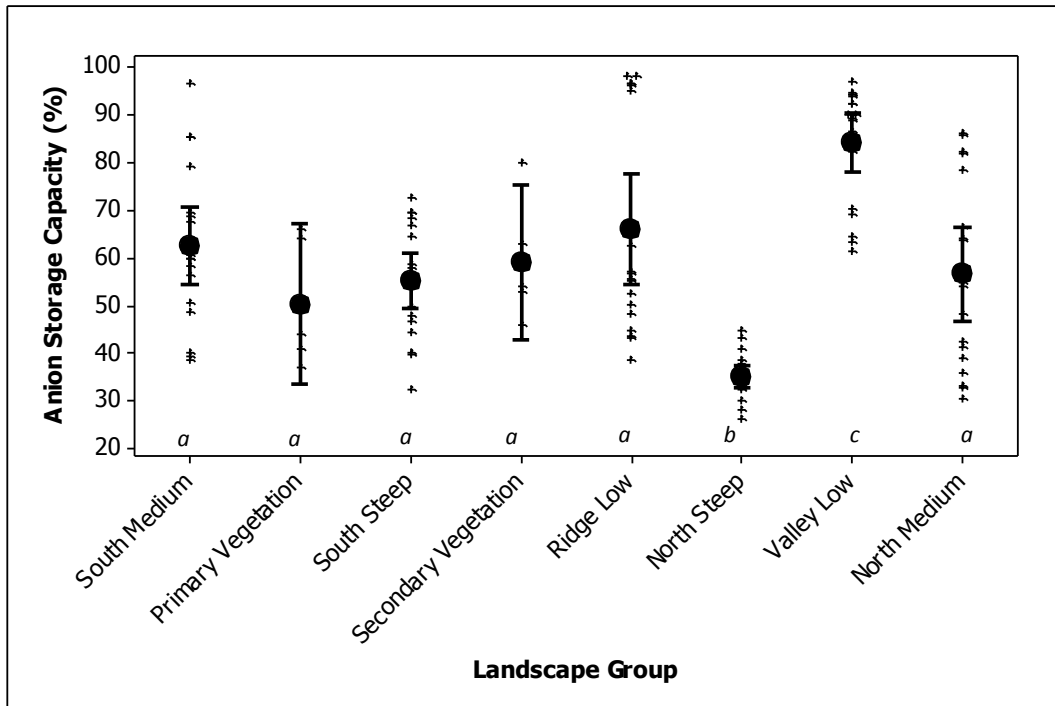

**Figure 4.19** The relationship between Olsen phosphorus ( $\mu\text{g/ml}$ ) and landscape groups. Error bars are 95% confidence intervals to the mean. Different letter notation for landscape groups indicate significant differences ( $p > 0.05$ ). Landscape unit groups with the same letter notation have no significant difference between them.

The sites with the highest Olsen P values (North facing medium slopes and Valley low slopes) also had the greatest variability in Olsen P levels (Figure 4.19). Olsen P levels were 'very low' in primary vegetation, south facing medium slope and south facing steep slopes landscape groups. Olsen P levels were 'low' in secondary vegetation, ridge low slopes, north facing steep slopes and valley low, and 'medium' in the north facing medium landscape unit.

### 4.3.2 *Anion Storage Capacity*

North facing steep slopes had the lowest ( $p < 0.01$ ) mean ASC level (35), and valley low had the highest ( $p < 0.01$ ) mean ASC level (84). There was no difference ( $P < 0.05$ ) between all other landscape groups (Figure 4.20).

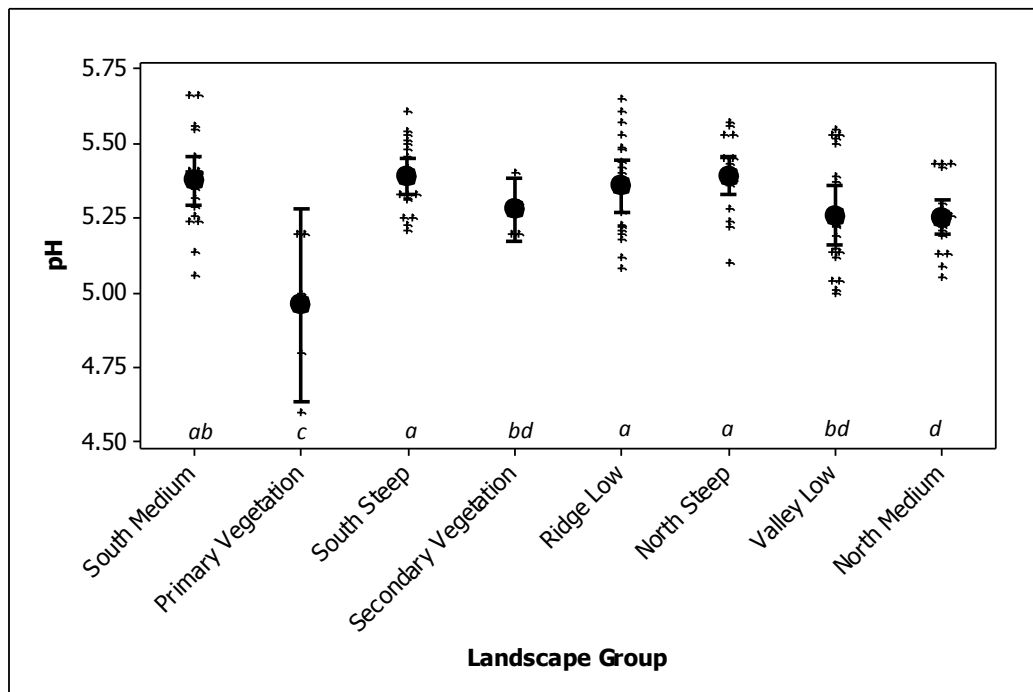

**Figure 4.20** The relationship between anion storage capacity (%) and landscape groups. Error bars are 95% confidence intervals for the mean. Different letter notation for landscape groups indicate significant differences ( $p > 0.05$ ). Landscape unit groups with the same letter notation have no significant difference between them.

Primary vegetation, south facing steep slopes, secondary vegetation, north facing steep slopes and north facing medium slopes had 'medium' ASC values. South facing medium slopes, ridge low slopes and valley low slopes had 'high' ASC values.

### 4.3.3 *Soil pH*

Excluding primary vegetation, the mean pH values for all other landscape groups were consistent (soil pH between 5.2 and 5.4). Primary vegetation had the lowest ( $P < 0.05$ ) soil pH value of 5, and north facing steep slopes had the highest ( $P < 0.05$ ) of 5.4 (Figure 4.21). Soil pH levels were analysed at Eurofins Laboratory, and Waikato University. Below are the soil pH values analysed by the Eurofins Laboratory. Results from Waikato University results are in the appendix (Table A4.1)

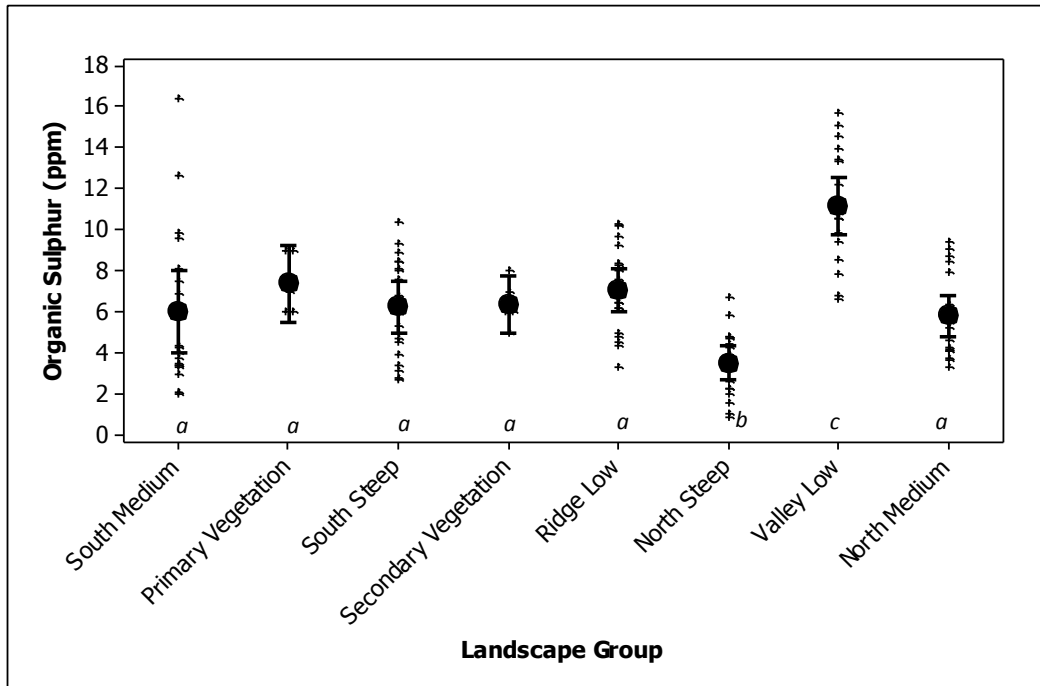

**Figure 4.21** The relationship between soil pH and landscape groups. Error bars are 95% confidence intervals for the mean. Different letter notation for landscape groups indicate significant differences ( $p > 0.05$ ). Landscape unit groups with the same letter notation have no significant difference between them.

The soil pH of primary vegetation was rated 'low'. All other soil landscape group's soil pH levels were rated 'medium'.

#### 4.3.4 Organic Sulphur

North facing steep slopes had higher ( $p < 0.05$ ) organic sulphur levels (3.6) than all other landscape groups. Valley low had the lowest ( $p < 0.05$ ) organic sulphur levels (11.2) of all landscape groups. The remaining landscape groups had no differences ( $P < 0.05$ ) in organic sulphur levels (Figure 4.22).

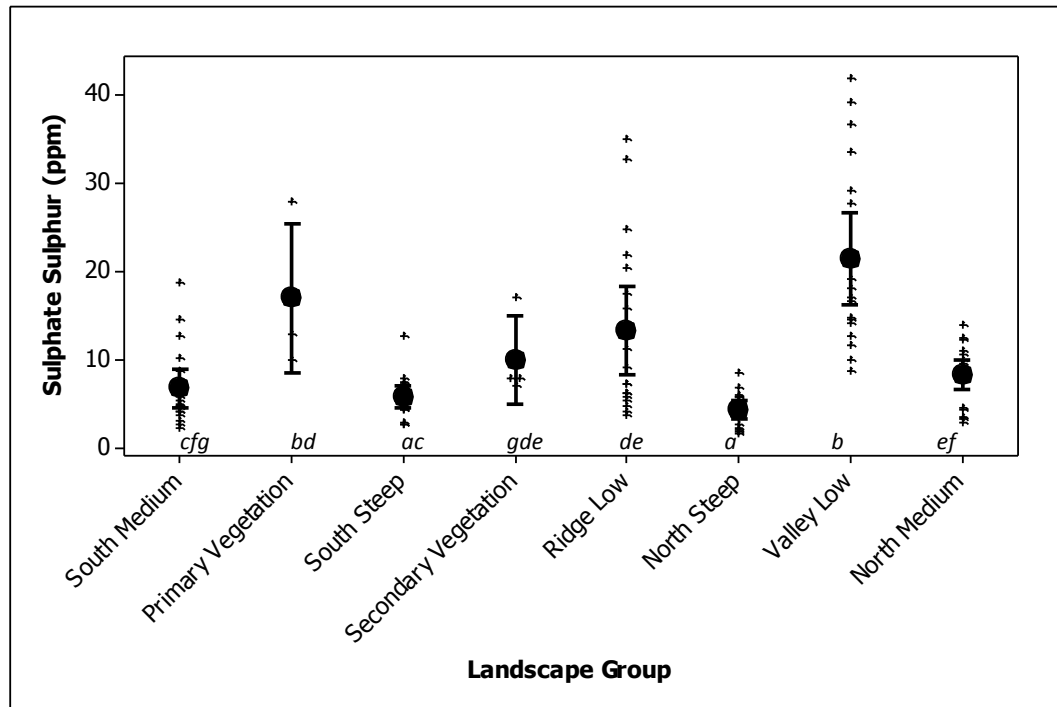

**Figure 4.22** The relationship between organic sulphur (ppm) and landscape groups. Error bars are 95% confidence intervals for the mean. Different letter notation for landscape groups indicate significant differences ( $p < 0.05$ ). Landscape unit groups with the same letter notation have no significant difference between them.

Organic sulphur values on north facing steep slopes were rated 'very low', all other landscape groups had values rated 'low'.

#### 4.3.5 Sulphate-sulphur

Sulphate-sulphur values ranged from a mean of 4.5 on north facing steep slopes, to a mean of 21.5 on valley low slopes (Figure 4.23).

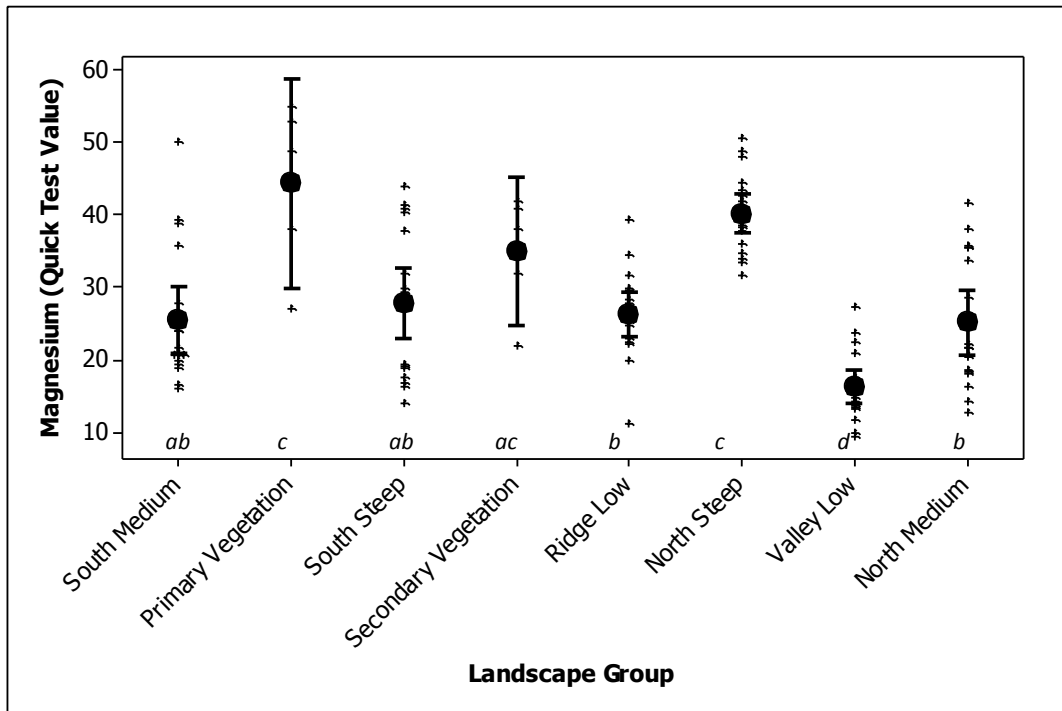

**Figure 4.23** The relationship between sulphate sulphur (ppm) and landscape groups. Error bars are 95% confidence intervals for the mean. Different letter notation for landscape groups indicate significant differences ( $p > 0.05$ ). Landscape unit groups with the same letter notation have no significant difference between them.

Sulphate sulphur levels on north facing steep slopes were rated 'very low', all other landscape groups were rated 'low'.

### 4.3.6 *Magnesium*

Valley low had the lowest ( $p < 0.05$ ) mean magnesium level of 45. Primary vegetation had the highest ( $P < 0.05$ ) mean magnesium level of 45 (Figure 4.24).

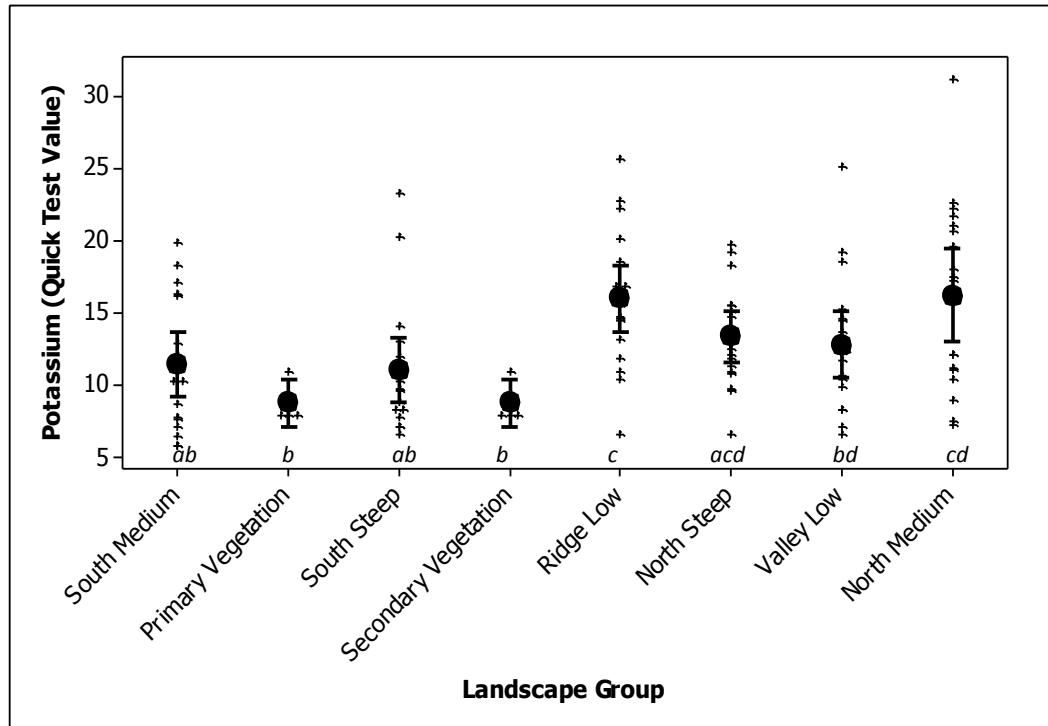

**Figure 4.24** The relationship between Magnesium (Quick Test Value) and landscape groups. Error bars are 95% confidence intervals for the mean. Different letter notation for landscape groups indicate significant differences ( $p > 0.05$ ). Landscape unit groups with the same letter notation have no significant difference between them.

Valley low slope was the only landscape groups with levels not in the recommended cation range.

### 4.3.7 Potassium

Potassium values ranged from a mean of 16.6 in the north facing medium slopes through to a mean of 9 for secondary vegetation sites (Figure 4.25).



**Figure 4.25** The relationship between potassium (Quick Test Values) and landscape groups. Error bars are 95% confidence intervals for the mean. Different letter notation for landscape groups indicate significant differences ( $p > 0.05$ ). Landscape unit groups with the same letter notation have no significant difference between them.

Primary native vegetation and secondary regrowth forest vegetation were the only landscape groups with means potassium levels not in the recommended cation range.



### 4.3.8 Calcium

North facing steep slopes had the highest ( $P < 0.01$ ) mean calcium level of 7.5. Valley low slope had the lowest ( $P < 0.05$ ) mean calcium level of 4.1 (Figure 4.26).

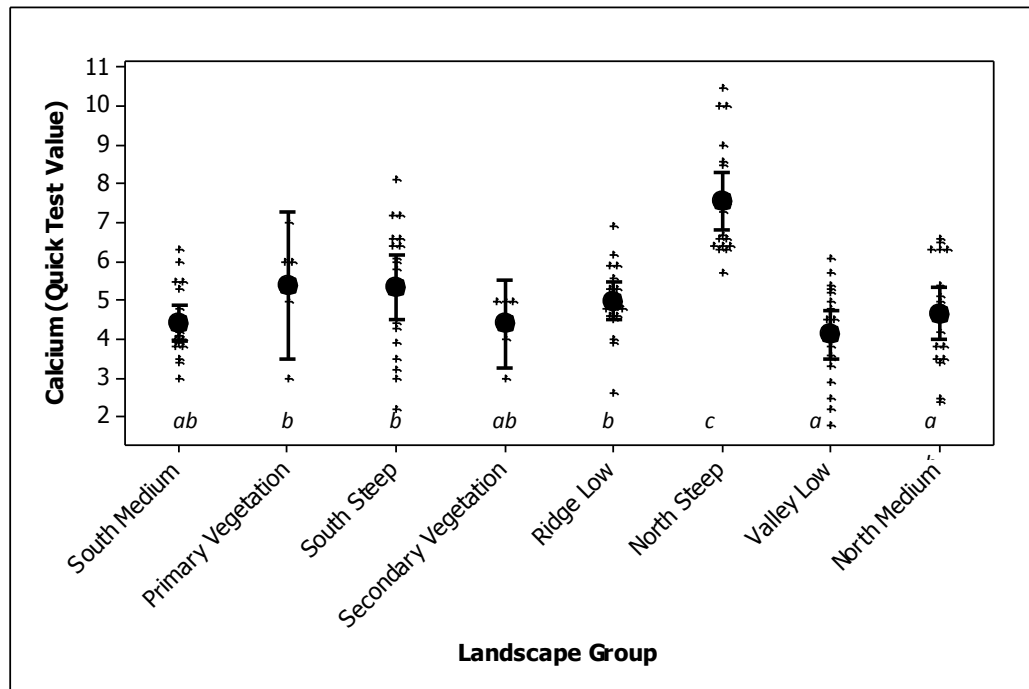
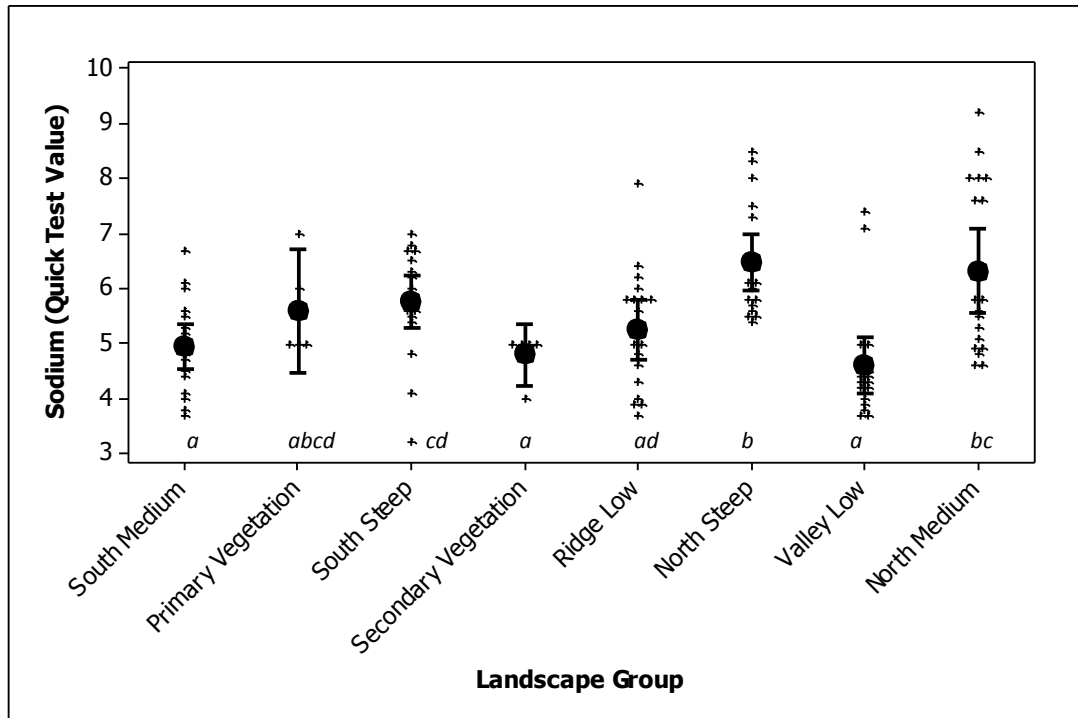

**Figure 4.26** The relationship between calcium (Quick Test Value) and landscape groups. Error bars are 95% confidence intervals for the mean. Different letter notation for landscape groups indicate significant differences ( $p > 0.05$ ). Landscape unit groups with the same letter notation have no

All landscape groups had mean calcium levels below the recommended cation level.

#### 4.3.9 Sodium

North facing steep slope had the highest ( $p < 0.05$ ) mean magnesium level of 6.5. Valley low slope had the lowest ( $P < 0.05$ ) mean magnesium level of 4.6 (Figure 4.27). All sodium levels were below recommended cation levels.



**Figure 4.27** The relationship between sodium (Quick Test Values) and landscape groups. Error bars are 95% confidence intervals for the mean. Different letter notation for landscape groups indicate significant differences ( $p > 0.05$ ). Landscape unit groups with the same letter notation have no significant difference between them.

## 4.4 Between sample variability

### 4.4.1 Introduction

To assess the between sample variability, sample replicates for each landscape unit were considered separately. At each sample site there were six samples, one from a transect sample and five from grid samples (section 3.12 – *Field Sampling – Pastoral Sampling*).

### 4.4.2 Olsen P

There was variability ( $p < 0.05$ ) between study site for all landscape groups, except for ridge low slopes (Figure 4.28). The within sample site (i.e. grid/transect) variability, e.g. NM1 is greater than the variability of the means across all study site.

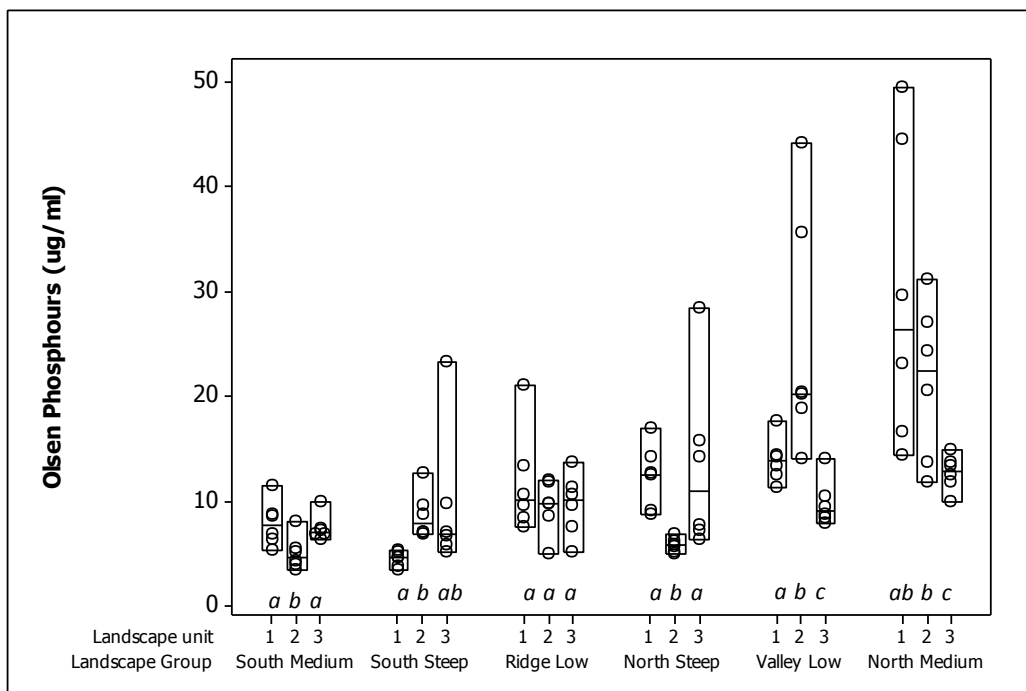

**Figure 4.28** Variation of Olsen phosphorus within landscape units. Different letter notation for landscape groups indicate significant differences ( $p > 0.05$ ). Landscape unit groups with the same letter notation have no significant difference between them.

#### 4.4.3 *Anion Storage capacity*

There was variability ( $p < 0.05$ ) between study site for all landscape groups (Figure 4.29). Two entire valley low study sites and one ridge low study site had ASC levels above 80%. All north facing steep sites were below an ASC level of 45%. ASC fluctuated within and between study sites remaining study sites.

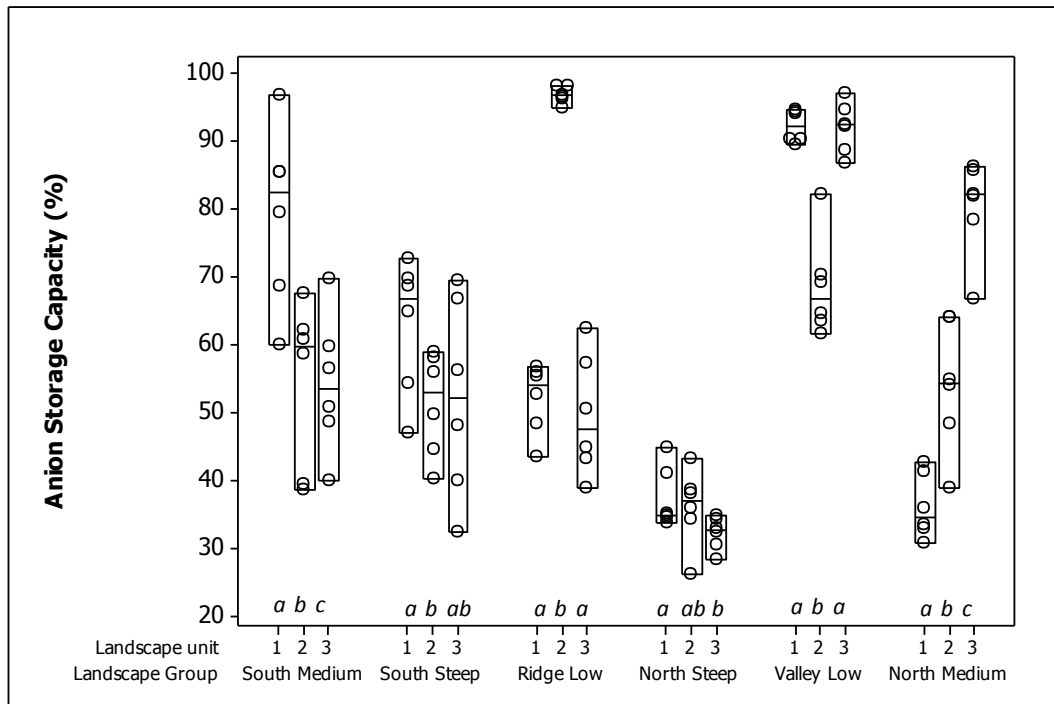

**Figure 4.29** Variation of anion storage capacity within landscape units. Different letter notation for landscape groups indicate significant differences ( $p > 0.05$ ). Landscape unit groups with the same letter notation have no significant difference between them.

4.4.4 *pH*

There were significant differences ( $P < 0.01$ ) between study site for north facing medium slopes, valley and ridge low slopes, and south facing medium slopes. The south facing steep slopes and north facing steep slopes showed no significant variability between sample sites (Figure 4.30).

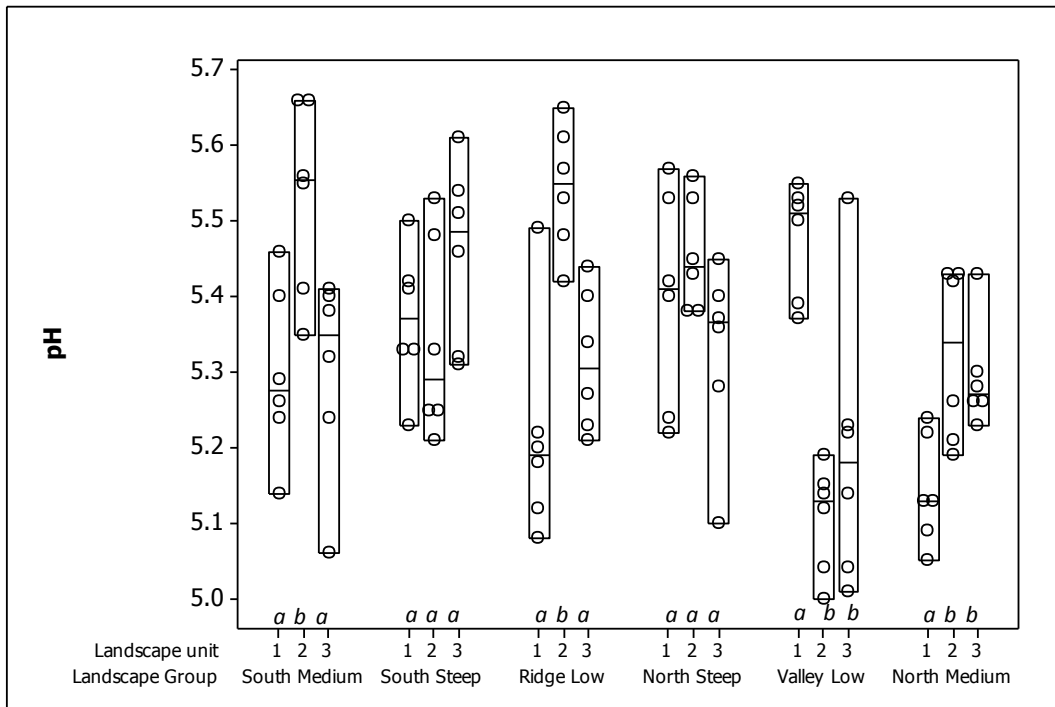

**Figure 4.30** Variation of pH within landscape units. Different letter notation for landscape groups indicate significant differences ( $p > 0.05$ ). Landscape unit groups with the same letter notation have no significant difference between them.

#### 4.4.5 *Organic Sulphur*

There was variability ( $p < 0.05$ ) between study site for all landscape groups (Figure 4.31).

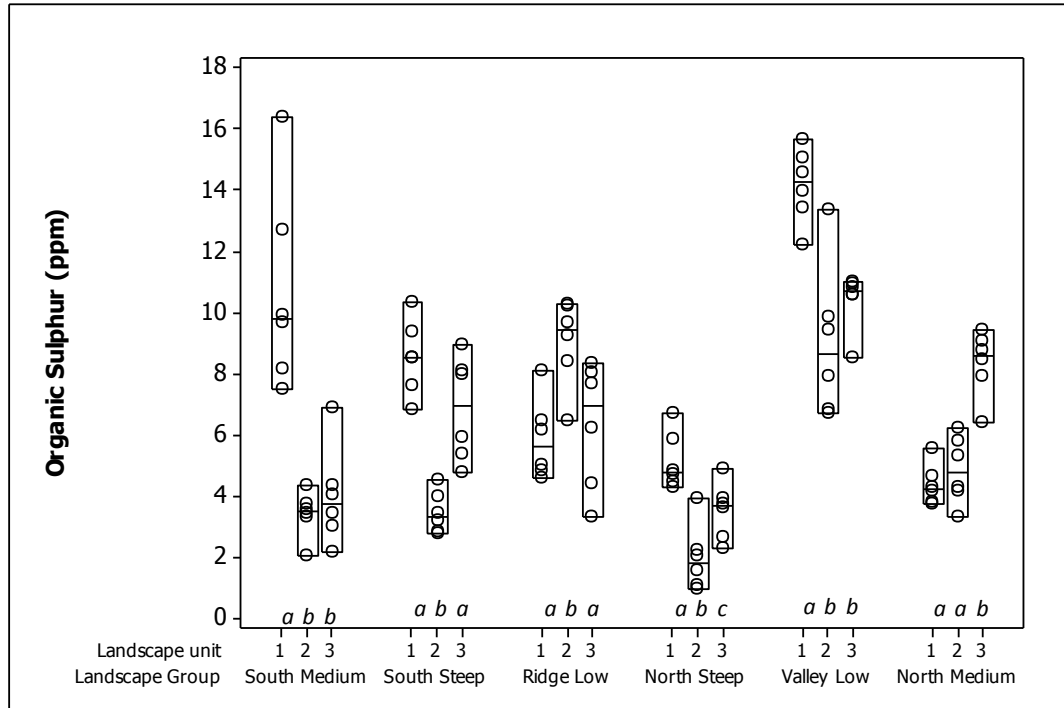

**Figure 4.31** Variation of organic sulphur within landscape groups. Different letter notation for landscape groups indicate significant differences ( $p < 0.05$ ). Landscape unit groups with the same letter notation have no significant difference between them.

#### 4.4.6 Sulphate-sulphur

South facing steep slopes were the only landscape group with no variability between study sites (Figure 4.32). The remaining landscape groups had variability between and within study sites.

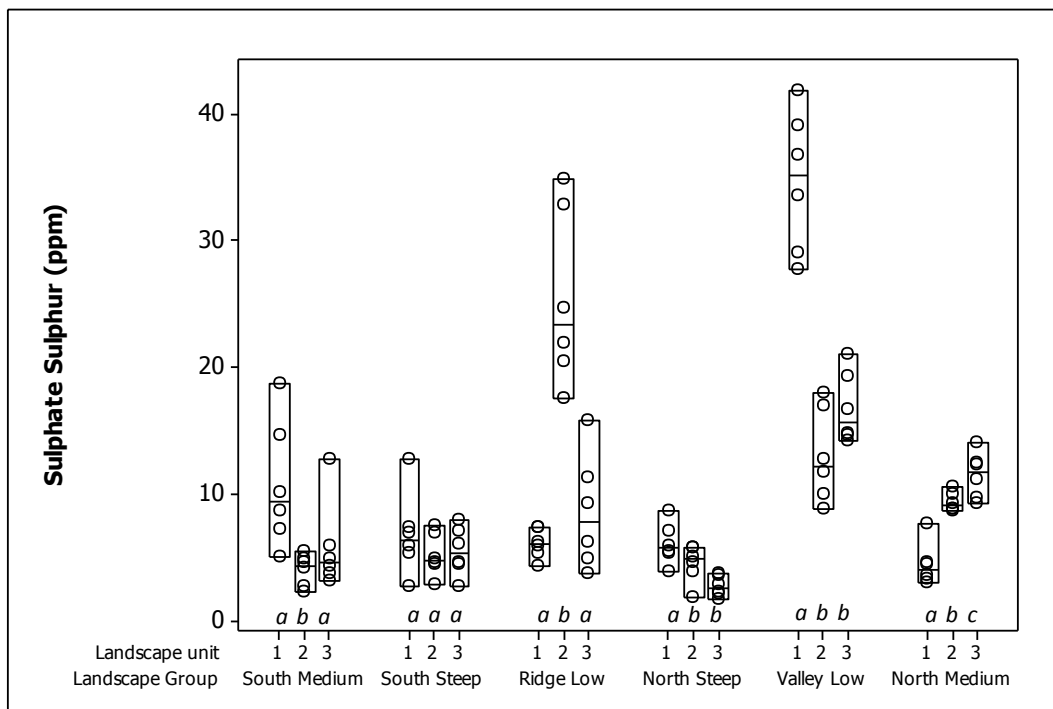

**Figure 4.32** Variation of sulphate sulphur within groups. Different letter notation for landscape groups indicate significant differences ( $p > 0.05$ ). Landscape unit groups with the same letter notation have no significant difference between them.

#### 4.4.7 *Magnesium*

North facing steep slope was the only landscape group with no variability between study sites (Figure 4.33). The remaining landscape groups fluctuated between and within study sites.

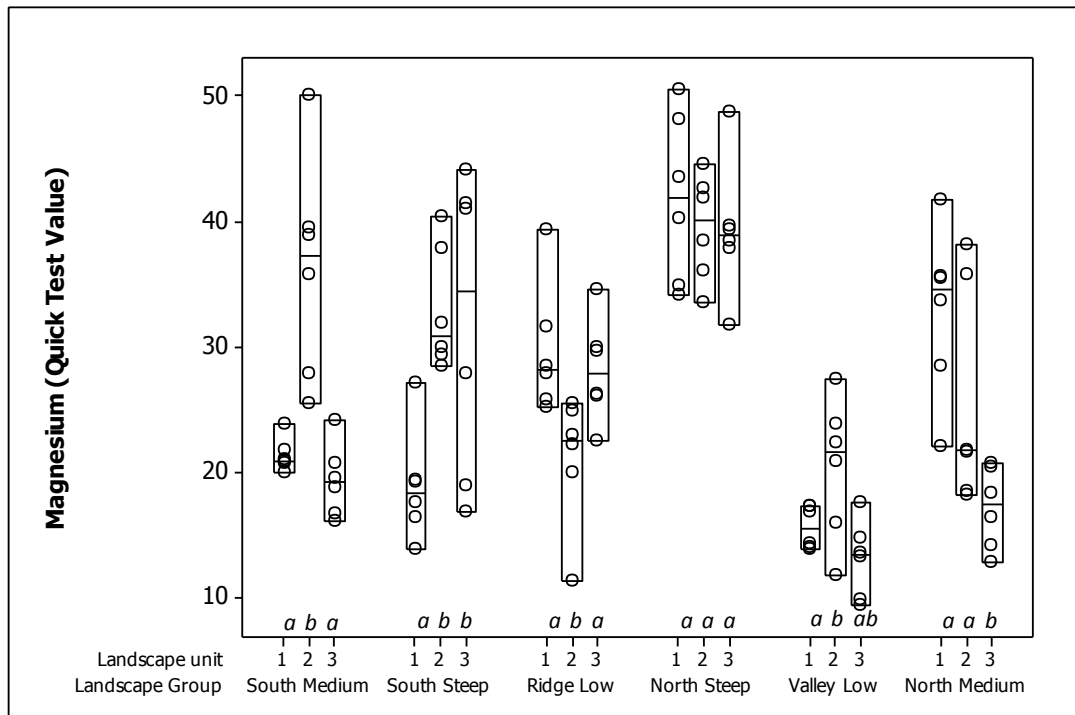
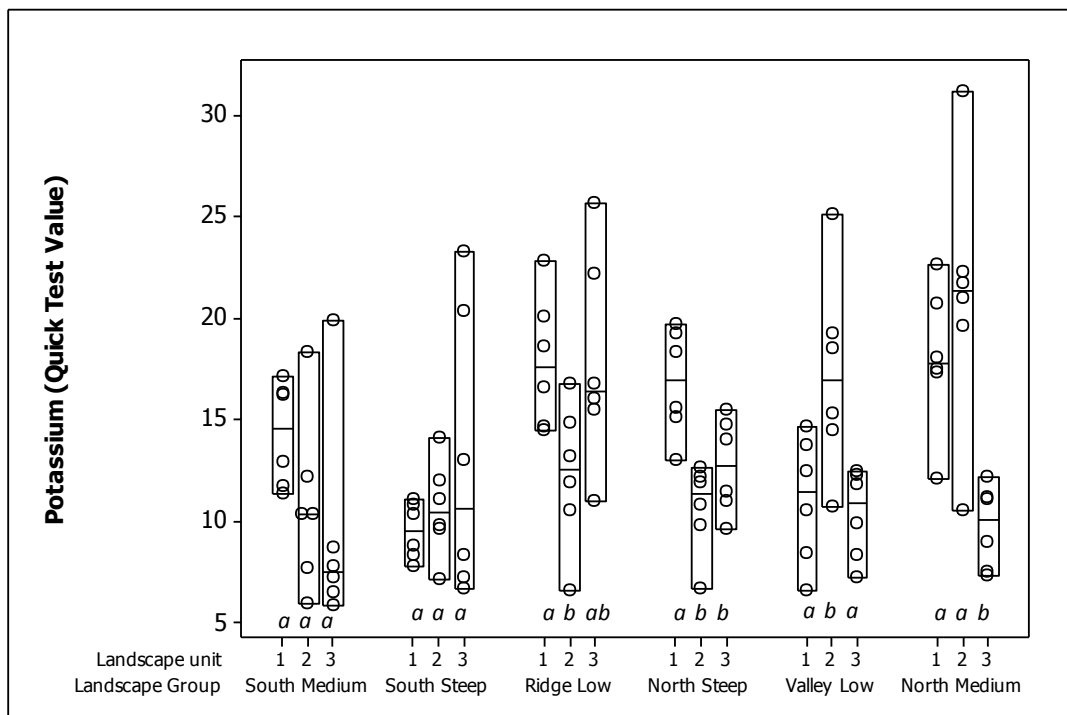

**Figure 4.33** Variation of magnesium within landscape groups. Different letter notation for landscape groups indicate significant differences ( $p > 0.05$ ). Landscape unit groups with the same letter notation have no significant difference between them.



#### 4.4.8 Potassium

There were significant differences ( $P < 0.01$ ) between study sites for north facing medium slopes, and valley and ridge low slopes. South facing steep slopes, south facing medium slopes and north facing medium slopes showed no variability between study sites ( $p < 0.05$ ) (Figure 4.34).



**Figure 4.34** Variation of potassium within landscape units. Different letter notation for landscape groups indicate significant differences ( $p > 0.05$ ). Landscape unit groups with the same letter notation have no significant difference between them.

#### 4.4.9 Calcium

There were significant differences ( $P < 0.01$ ) between study site for north facing steep and north facing medium slopes, valley low slopes, south facing steep slopes and south facing medium slopes. Ridge low slope showed no variability between study sites (Figure 4.35).

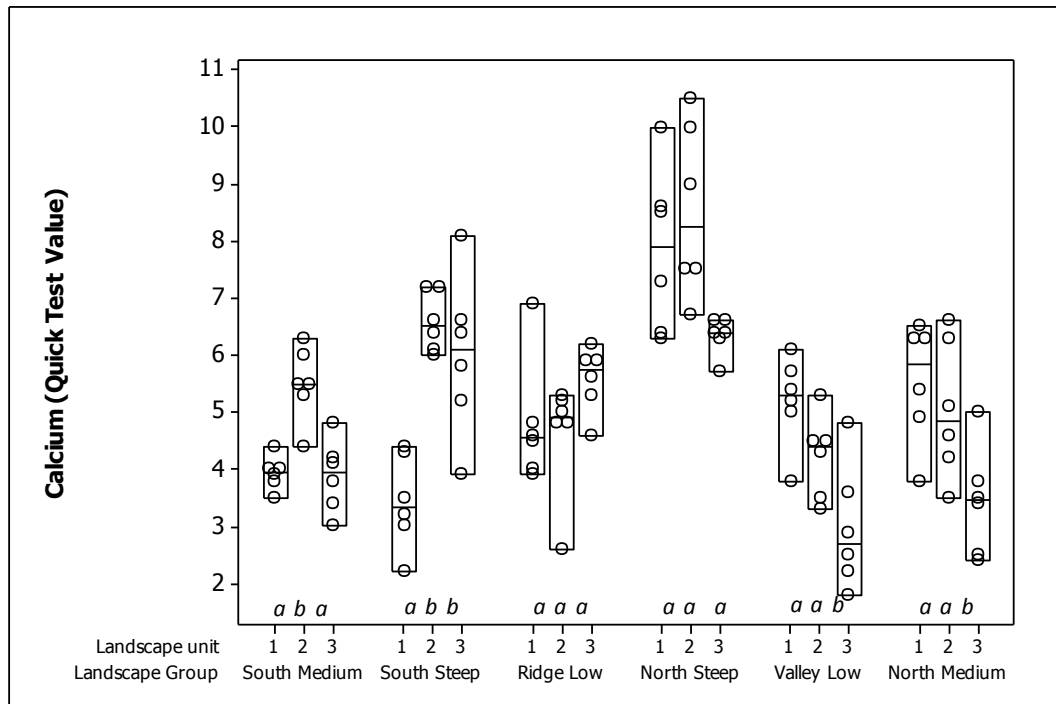

**Figure 4.35** Variation of calcium within landscape groups. Different letter notation for landscape groups indicate significant differences ( $p > 0.05$ ). Landscape unit groups with the same letter notation have no significant difference between them.

#### 4.4.10 *Sodium*

There were significant differences ( $P < 0.01$ ) between study site for landscape groups, north facing medium slopes, valley and ridge low slopes. South facing steep slope showed no variability between study site ( $p < 0.05$ ) (Figure 4.36).

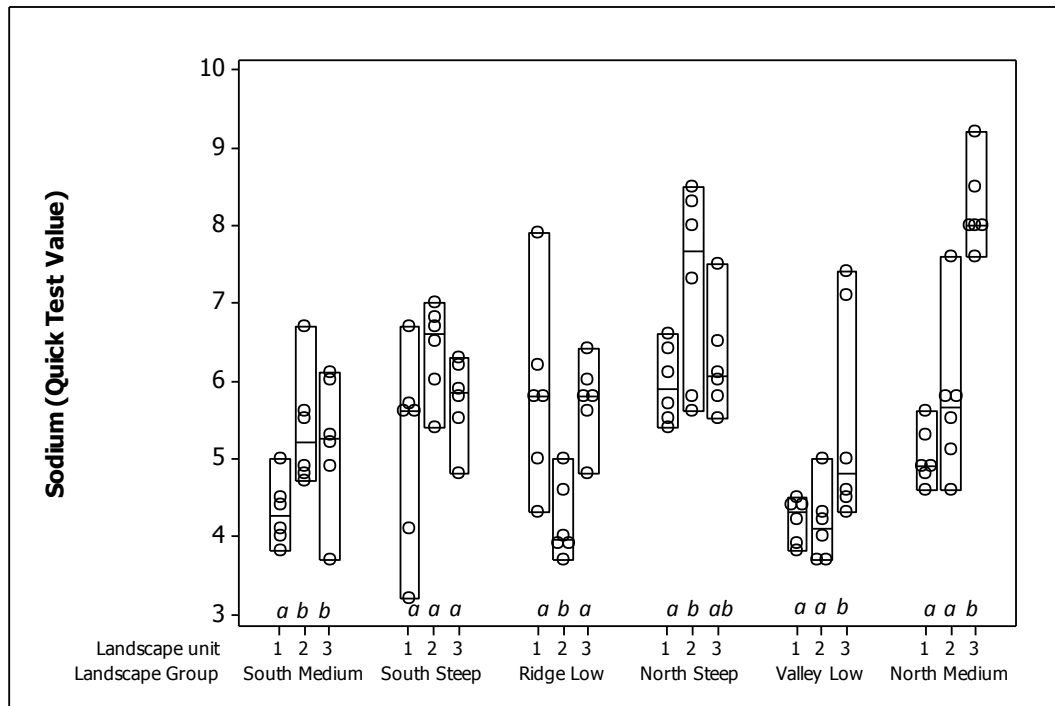

**Figure 4.36** Variation of sodium within landscape groups. Different letter notation for landscape groups indicate significant differences ( $p > 0.05$ ). Landscape unit groups with the same letter notation have no significant difference between them.

4.4.11 Between variable relationshipsa) *Relationship between ASC and Calcium*

ASC was weakly negatively correlated with calcium,  $r^2 = 0.4$  (Figure 4.37)

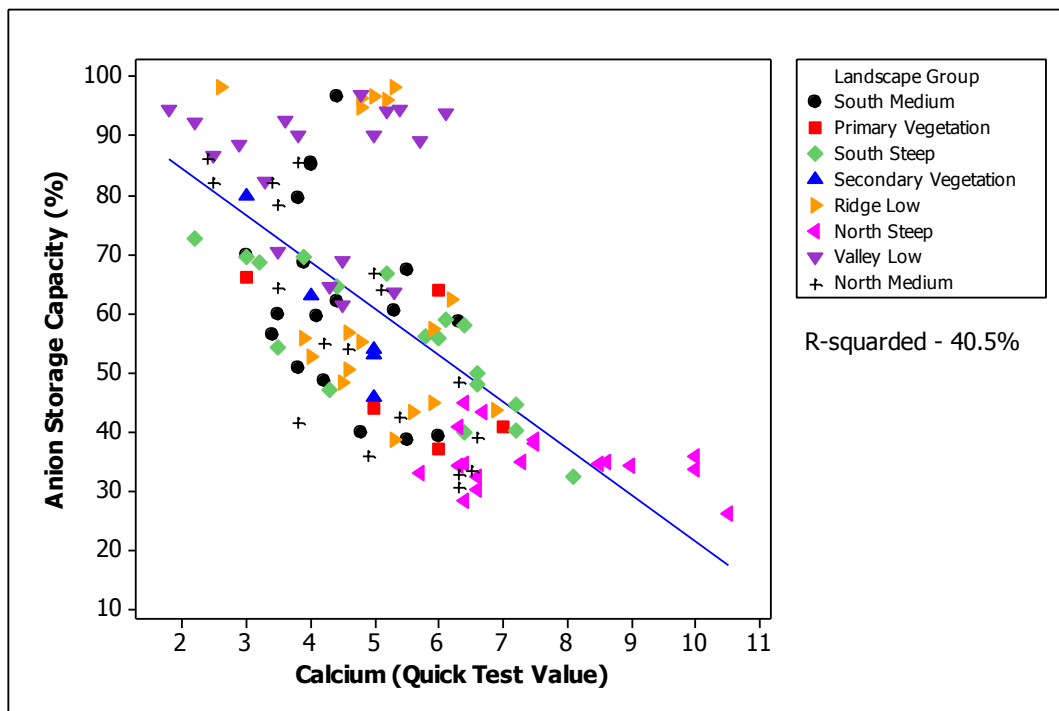

**Figure 4.37** Scatter plot of anion storage capacity and calcium with a linear regression line to show the relationship.

b) Relationship between ASC and organic sulphur

ASC was positively correlated with organic sulphur,  $r^2 = 0.65$  (Figure 4.38)

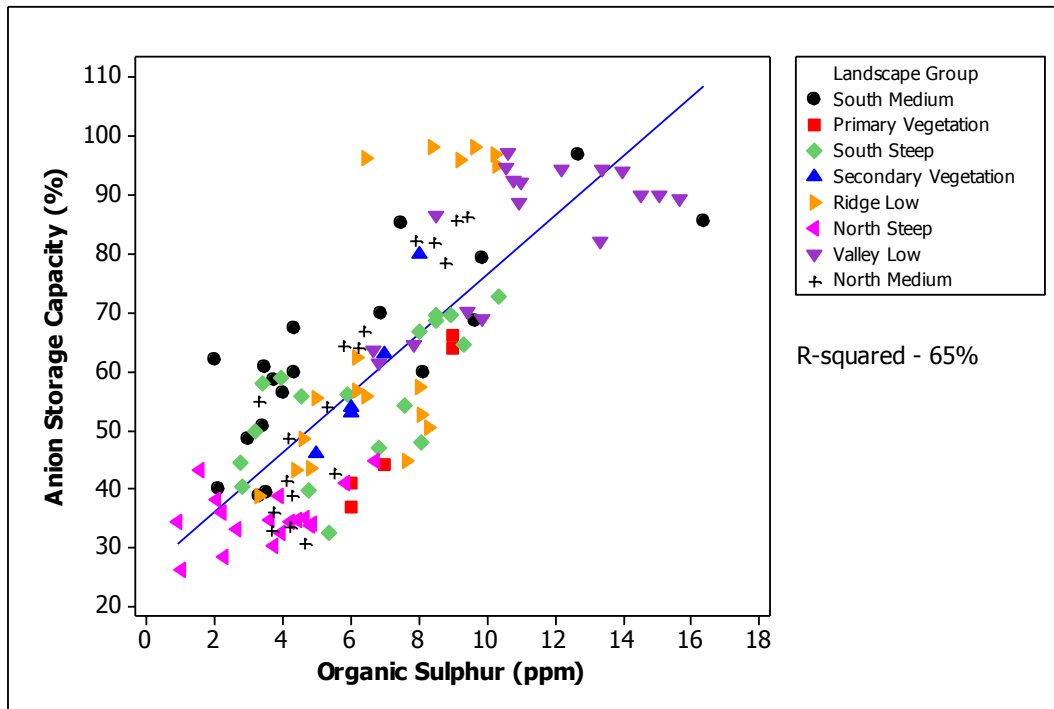

**Figure 4.38** Scatter-plot of anion storage capacity and organic sulphur with a linear regression line to show the relationship.

## c) Relationship between ASC and magnesium

ASC was negatively correlated with magnesium,  $r^2 = 0.6$  (Figure 4.39)

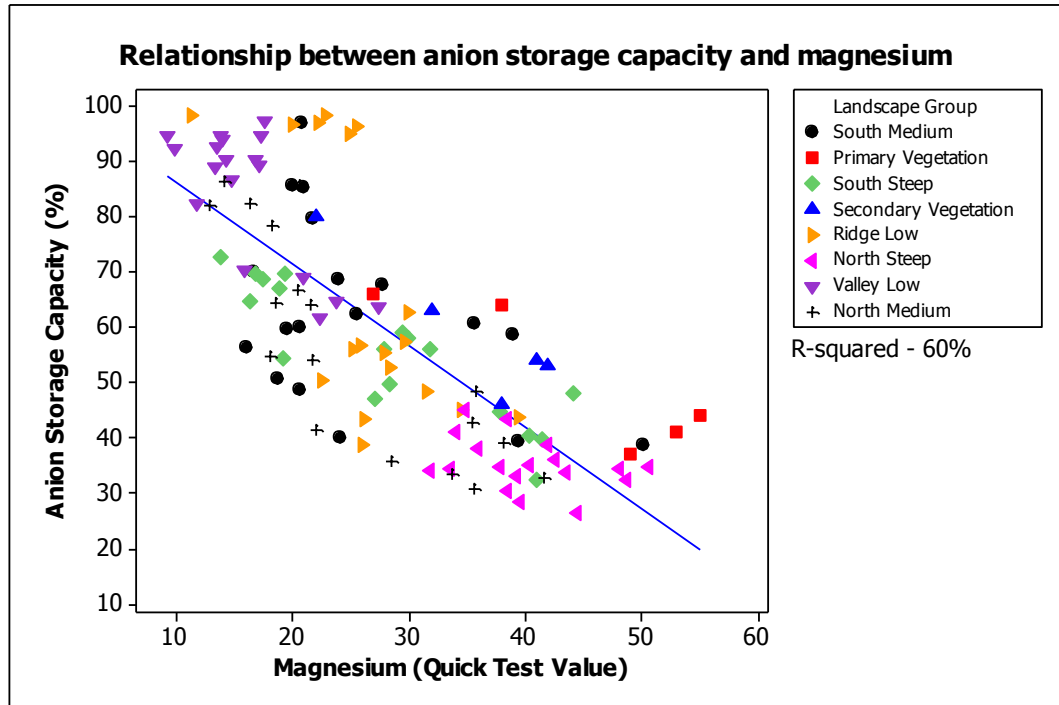

**Figure 4.39** Scatter plot of anion storage capacity and magnesium with a linear regression line to show the relationship.

## d) Relationship between Olsen P and potassium

Olsen P was positively correlated with potassium,  $r^2 = 0.37$  (Figure 4.40)

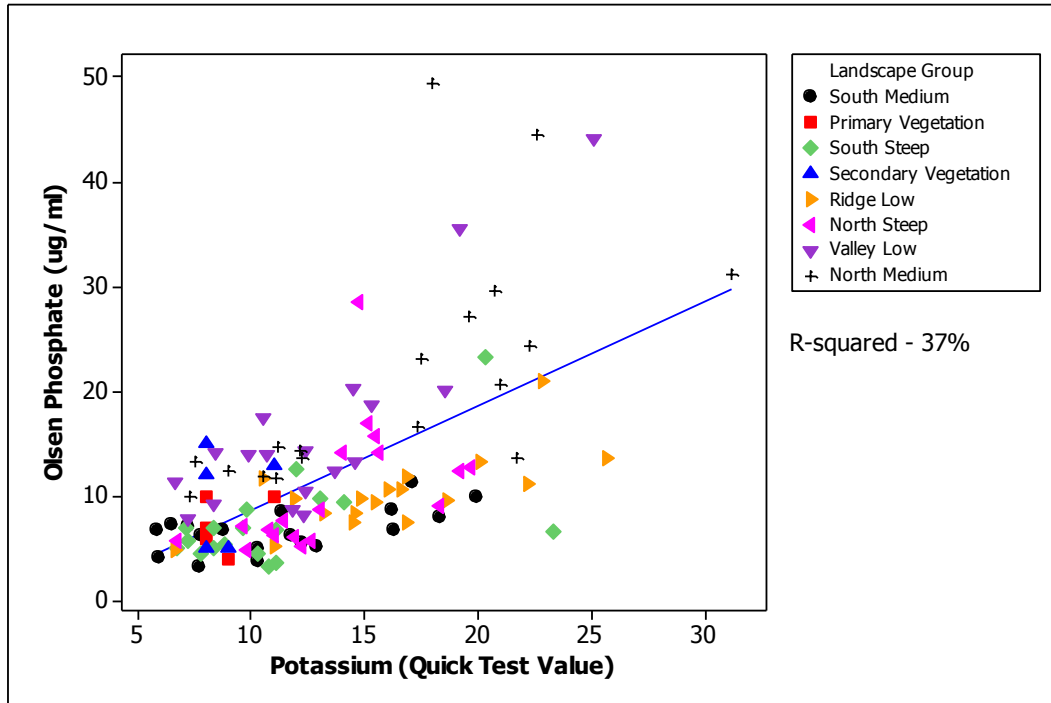

**Figure 4.40** Scatter plot of Olsen P and potassium with a linear regression line to show the relationship.

## e) Relationship between organic sulphur and sulphate sulphur

Organic sulphur had a positive correlation with sulphate sulphur,  $r^2 = 0.5$ . (Figure 4.41)

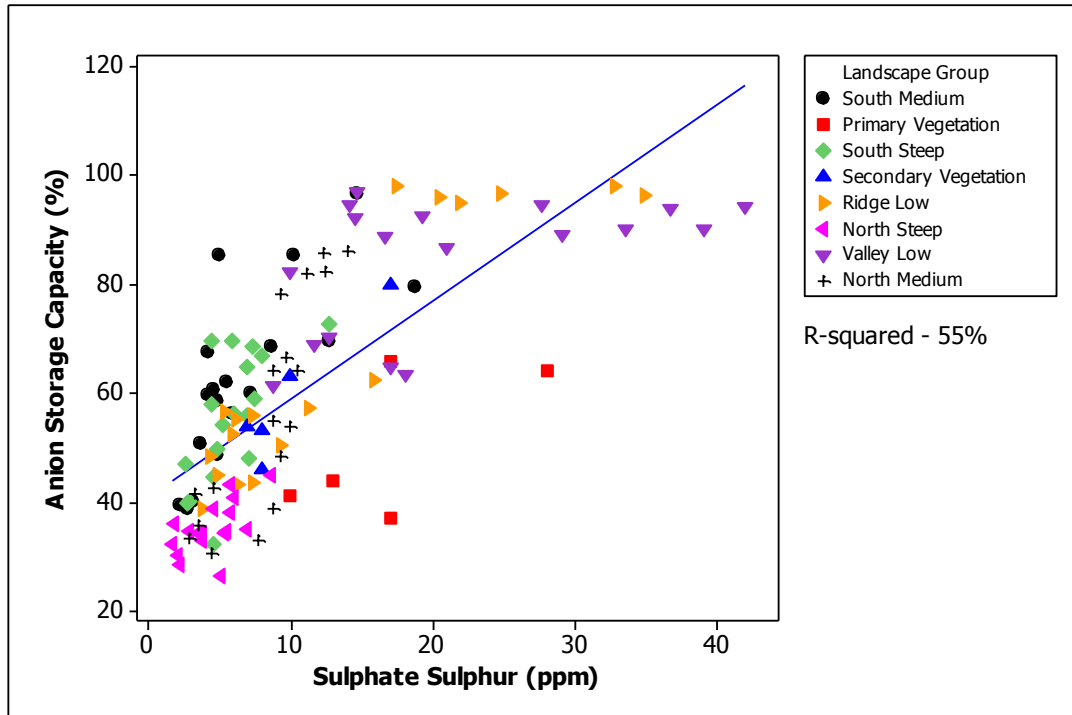

**Figure 4.41** Scatter plot of organic sulphur and sulphate sulphur with a linear regression line to show the relationship.





# Chapter 5

## Discussion and Conclusion

### **5.1. Introduction**

Blue Duck Station was delineated into six different soil-landscape groups, using aspect, slope and elevation. The six soil-landscape groups identified were; north medium (slopes of 13-25°, aspect >270° <90°), south medium (slopes of 13-25° aspect <270° >90°), north steep (slopes of >25° aspect >270° <90°), south steep (slopes of >25°, aspects <270° >90°), ridge low (slopes of 1-12 °, >400 m elevation), and valley low (slopes of 1-12 °, < 150 m elevation). Three study-sites within each of the 6 landscape groups were randomly chosen, which gave 18 study-sites in total. For each study site, one transect sample and five grids samples were collected. Olsen P, Anion Storage Capacity, pH, Sulphate-sulphur and Cations (Mg, Na, K, Ca) were determined for each sample.

Two vegetated sites in different stages of ecological succession were sampled to compare soils under pasture and native vegetation. “Primary vegetation” is an area of virgin native forest which has never been cleared for pastoral use, and “secondary vegetation” is an area of regrowth forest was previously cleared for pastoral use, but allowed to revert back to its native state.

The overall objective of my study was to measure the variability of soil phosphorus and other soil chemical properties, to determine whether precision agriculture methods could be applied to hill and steep land areas to maximise P fertiliser use efficiency. My hypothesis was that landscape groups could be used to determine fertiliser recommendations to maximise productivity and minimise adverse environmental effects in hill slope landscapes in the King Country.

This chapter discusses the results that were presented in chapter four. It discusses potential explanations for the variability of soil chemical properties within the landscape, evaluates varying fertiliser scenarios, and states recommendations for Blue Duck Station. This chapter also debates traditional soil sampling methods, discusses potential for runoff recommendations and compares Blue Duck Station's soil chemical properties with a the Ballantrae Hill Country Research Station.

## **5.2 *Variability of soil chemical properties***

### **5.2.1 *Introduction***

Hill country farms are dynamic systems, lacking uniformity in both physical and chemical properties. They are comprised of mixed slopes, aspects, stock transfers, and parent material. The variability influences soil chemical properties, soil fertility, and fertiliser requirements. When soil samples from Blue Duck Station were analysed, variability was seen in every facet of sampling. This included variability from one landscape group to the other (e.g. Figure 4.23), variability between replicate (e.g. Figure 4.29), and variability within sample replicates (e.g. Figure 4.19). When applying fertiliser to hill country farms, misunderstanding soil nutrient variability, can be the difference between under-fertilisation and over-fertilisation. Potential influences on the variability of soil chemical properties at Blue Duck Station are discussed below.

### **5.2.2 *Source of soil chemical variability***

#### ***c) Parent material and topographical variability***

The presence or absence of allophane can indicate the source of a soils parent material in the Central North Island of New Zealand. Of the soil chemical analyses undertaken at Blue Duck Station, anion storage capacity (ASC) can be used to indicate whether or not a soil contains allophane. ASC is the measure of a soils ability to retain anions like phosphate and sulphate, a high ASC can indicate the presence of tephra containing soils (volcanic) and a low ASC can indicate soil derived predominantly from tertiary sedimentary material.

Tephra deposited from vents in the Rotorua and Taupo district have mantled the King Country landscape (McCraw, 1974). However, tephra is not deposited equally (ASC at Blue Duck Station decreased with increasing slope) throughout the landscape; the location of deposits are influenced by erosion, accumulation and mixing. Steep slopes and select ridges are highly erosion prone, causing tephra material to accumulate to the greatest extent on the valley floors. The Field-Perot allophane test (Milne, 1991) indicated positive allophane test on the valley floors, negative allophane tests on the steep slopes, and somewhat weak allophane reaction on the ridges (Table 5.1).

**Table 5.1** Allophane test on selected landscape groups

Landscape groups	Sample Replicate					
	Transect	Grid	Grid	Grid	Grid	Grid
	Sample	sample 1	sample 2	sample 3	sample 4	sample 5
North steep slope 1	N	N	N	N	N	N
North steep slope 2	N	N	N	N	N	N
North steep slope 3	N	N	N	N	N	N
South medium 1	A	A	WA	A	A	A
Valley low 1	A	A	A	A	A	A
Valley low 2	WA	WA	A	A	WA	WA
Valley low 3	SA	SA	SA	SA	A	WA
Ridge low 1	N	N	N	N	A	N
Ridge low 2	A	A	A	A	A	A
Ridge low 3	N	N	N	WA	WA	N
Virgin forest	N	MA	N	N	N	N
Re-growth	N	N	N	N	WA	N

N – Non Allophanic WA – Weakly Allophanic MA – Mildly Allophanic SA – Strongly Allophanic

Two interesting results were evident from Blue Duck Station's allophane test (Table 5.1). South facing medium slopes had a mixture of positive allophane results, between replicate samples from the same site. Potentially being an indication of micro-topographical influences, where small dips in the topography retain initial volcanic deposition, and/or collect allophonic soil from eroded sites above. Also, flat ridge tops that were expected to contain allophane, had samples which contained no allophane or showed weak allophane reactions. This may be due to deposited tephra material being 'blown' off the exposed ridges, and eroded down slope.

Calcium and Magnesium can be used to indicate sedimentary parent material (assuming little lime, super (Ca) and Mg fertiliser have been applied). Soil chemical analysis at Blue Duck Station indicated that the highest calcium and magnesium levels were found on the steep slopes, with lower calcium and magnesium concentration on the low slopes. The high calcium levels on steep slopes are likely derived, not from fertiliser, but from calcareous sedimentary parent materials. As calcium/magnesium levels increase with slope, ASC levels decrease. Due to ASC indicating tephra derived parent material, this relationship reinforces the fact that steep slopes are dominated by sedimentary materials (low ASC, high magnesium and calcium), and lower slopes are primarily tephra dominant (higher ASC levels and lower calcium and magnesium levels) (Figure 5.1).

***Calcareous soils derived predominantly from Tertiary sedimentary, located on steep slopes rocks***



***Soil containing tephra, located on low slopes***



**Figure 5.1** Soil profile showing the differences between sedimentary (calcium rich, low ASC) soils and volcanic (low calcium high ASC).

*d) Stock influence*

The transfer of nutrients throughout hill country farms is dominated by animal habits. Stock transfer nutrients from areas where they graze, on steeper slopes, to areas where they rest and excrete, on lower slopes (Daniel, *et al.*, 1998). Consequently, soil phosphorus and potassium levels often increase under areas of animal congregation (Sigua, *et al.*, 2011, Haynes & Williams, 1999). Saggar *et al.*, (1990) measured the accumulation of animal excretion on low, medium and steep slopes. The results showed that varying slope classes with similar areas received different excretion levels. Totals stock excretion occurs 60% on low slopes, 30% on medium slopes, and 10% on steep slopes. Williams & Haynes (1990) presented similar results, showing that soil phosphorus under stock camps increased by 38%. Both Blue Duck Station and Ballantrae Research Station had their highest potassium and Olsen P levels on low slopes, potential evidence of stock transfer to low slopes.

*e) Aspect and slope influence on pasture production*

Varying climatic conditions due to slope and aspect can influence pasture production. South facing slopes are cool and have higher overall soil moisture content due to lower evapotranspiration, which leads to increased White clover growth. North facing slopes are warmer (receiving up to 80% more solar radiation (Radcliffe & Lefever, 1987)), dryer, and dominated by Subterranean clover and native legumes. North facing slopes also have the highest pasture production of any slope and aspect class (Gillingham, *et al.*, 1998, Gillingham, *et al.* 2003b, Gillingham, *et al.*, 2007, Gillingham A. *et al.*, 2008ab). This is reinforced with Blue Duck Station's northern facing slopes having the highest Olsen P, potassium, magnesium, calcium and sodium levels.

*f) Past fertiliser history*

The application of phosphorus fertiliser influences soil chemical properties. A good predictor of past fertiliser application is the relationship between Olsen P and anion storage capacity (laboratory measure of P buffer capacity) (Lambert, *et al.*, 1998, Edmeades. *et al.*, 2006). The high P buffer capacity associated with high ASC, means that more P fertiliser is needed to raise the Olsen P level of a soil with a high ASC, than a soil with a low ASC. Therefore, if P fertiliser has been applied, ASC and Olsen P will have a negative linear relationship. However, if there has been limited fertiliser applied, the ASC will not have had the opportunity to 'buffer' any additions to soil P, therefore the soil ASC will not be related to Olsen P levels. At Blue Duck Station, no relationship between ASC and Olsen P was seen, evidence of limited past fertiliser application.

The relationship between sulphate-sulphur and organic sulphur is another indicator of past fertiliser effects. Sulphate-sulphur is the immediate plant available soil sulphur – affected by fertiliser– whereas organic sulphur is the natural pool of soil S – not influenced by fertiliser (Edmeades, 2003a). If there has been no past fertiliser application, the natural, undisturbed relationship between organic sulphur and sulphate sulphur is in quasi equilibrium, (can be considered the same entity). However, the application of fertiliser disturbs the

natural relationship between organic sulphur and sulphate sulphur. Blue Duck Station had a positive linear relationship between sulphate sulphur and organic sulphur, indicating limited past fertiliser application.

No fertiliser has been applied to native forested sites at Blue Duck Station; therefore, the relationship between pastoral sites and primary forested sites (similar aspect and slope) can be used as an indicator of past fertiliser application. Soil chemical results showed that forested and pastoral sites had similar anion storage capacity and Olsen P levels. The similarity between native forest vegetation and pastoral vegetation again demonstrated limited past fertiliser application at Blue Duck Station.

*g) Vegetation influences*

Soils under native forest vegetation at Blue Duck Station had the lowest soil pH levels (Table 5.2). Low soil pH levels are typical of New Zealand native forests, due to thousands of years of undisturbed forest cover, allowing the soils to accumulate acidic litter, dropped by native conifer–broadleaf vegetation (Sparling & Schipper, 2004, Hewitt, 2009).

Sulphate sulphur is a component of organic matter, and able to be used as an indicator of organic matter accumulation. At Blue Duck Station, virgin forest vegetation had higher ( $P < 0.05$ ) sulphate sulphur levels than pastoral sites. The elevated sulphate sulphur levels may be due to a combination of higher rates of organic matter accumulation, increased organic sulphur mineralisation, and high levels of microbial activity, as a result of moist shaded soils (Haynes & Williams, 1999, Edmeades, *et al.*, 2003).



**Table 5.2** Comparison between pastoral, primary forested vegetation and secondary re-growth forest vegetation sites, all located on south facing medium slopes. Different letter notation for landscape groups indicate significant differences ( $p>0.05$ ).

Soil Chemical Property	Pastoral Site	Primary Vegetation	Secondary Vegetation
ASC	62.65	50.49	59.03
Ca	4.44	5.46	4.46
K	11.45	8.66	8.92
Mg	25.63a	44.12b	34.96ab
Na	4.96	5.46	4.52
OS	6.03	7.46	6.33
P	6.71	7.35	9.96
pH	5.38a	4.94b	5.26ab
SO <sub>4</sub>	6.81a	16.96b	10.12ab

### 5.3 *Fertiliser scenarios and recommendations for Blue Duck Station*

#### 5.3.1 *Introduction*

Fertiliser additions can maximise pasture production by attaining optimal Olsen P levels. However, variable Olsen P levels throughout the landscape make blanket fertiliser application redundant. Blanket fertiliser application, over-fertilises some areas, while under-fertilising others. Applying too much fertiliser to a farm, reduces profitability and increases the risk of phosphorus additions to the environment. Of equal negative consequence is applying too little fertiliser, reducing pasture production, and farm profits (Edmeades, 2003b).

### 5.3.2 Varying sampling, and fertiliser scenarios

In a farming system, phosphorus is the most expensive nutrient, however, to maximise production of a legume-based system, its application is vital. The per hectare gross margin (net income minus the variable costs) of a farm is a valuable measure of its profitability (Edmeades, 2002b). The average gross margin of a Manawatu-Taranaki hill country sheep and beef farm is 606 (\$/ha), which requires an optimal Olsen P of 22  $\mu\text{g}/\text{ml}$  to be achieved (Beef and Lamb New Zealand, 2010) (Figure 5.2). The Manawatu-Taranaki hill country regions optimal Olsen P of 22 was used in my calculation for Blue Duck Station. An Olsen P of 22, is not dissimilar to the optimal Olsen P (90-95% of the biological maximum) of 20, established by Ledgard, *et al.*, (1991).

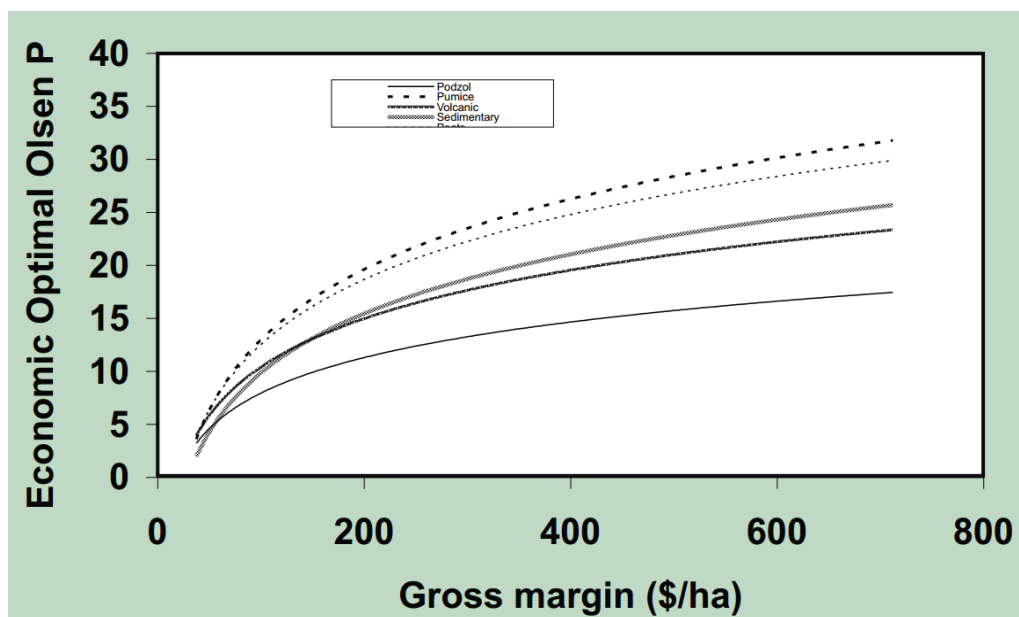

**Figure 5.2** Relationship between economic optimal Olsen P and gross margin (\$/ha) (Edmeades, 2002)

Once a target Olsen P level was decided upon, six hypothetical sampling scenarios were generated, allowing for a range of differential fertiliser treatments to be created and compared (Table 5.3)

Table 5.3 Fertiliser cost to raise current Olsen P level to optimal Olsen P level at Blue Duck Station, based on various sampling scenarios

<i>Sampling type</i>	<i>Average Olsen P</i>	<i>Olsen P units to optimal*</i>	<i>Fertiliser needed to raise to optimal (kg/ha)**</i>	<i>Fertiliser cost to optimal (\$/ha)***</i>	<i>Area in Hectares (Ha)</i>	<i>Cost for farm (\$)</i>
<b>a) Medium slope</b>	14.0	8.0	450.0	157	260	<b>40,820</b>
<b>b) Averages of all data</b>	12.0	9.9	555	195	260	<b>50,700</b>
<b>c) Weighted average</b>	11	11	616	216	260	<b>56,160</b>
<b>d) Low slopes</b>	13.3	8.7	487	170	260	<b>44,200</b>
<b>e) Aspect</b>						
<b>North slopes</b>	15.8	6.2	347	121	116	14036
<b>South slopes</b>	6.7	15.2	851	297	113	33561
<b>Low slopes</b>	13.3	8.7	487	170	33	5610
					<b>Total</b>	<b>53207</b>
<b>f) Aspect and Slope</b>						
<b>North Steep</b>	10.4	11.6	644	225	81	18225
<b>North Medium</b>	21.2	0.8	43	15	35	525
<b>South Steep</b>	7.5	14.5	810	283	73	20659
<b>South Medium</b>	6.7	15.2	851	297	40	11880
<b>Valley Low</b>	16.4	5.6	313	110	23.4	2574
<b>Ridge Low</b>	10.2	11.8	660	231	9.6	2220
					<b>Total</b>	<b>56,083</b>

\* Economic Optimal Olsen P of 22 is based on a gross margin aim of 606 (\$/ha), which is the average North Island hill country farm average

\*\* Superphosphate to raise Olsen P 1 unit - 56Kg/ha sedimentary soil (Morton *et al.*, 1994)

\*\*\* Fertiliser price 355\$/Metric Ton = 0.35\$/Kg – Ravensdown

**a) Medium slopes** - based on the assumption that the entire farm will be fertilised based on rates calculated by soil test values of medium slopes

**b) Average of all data** – the entire farm would be fertilised based on rates calculated by the average of all my soil test values over all slopes and aspects of the farm

**c) Weighted average** - the entire farm would be fertilised based on rates calculated by the weighted average (the contribution of the data point to the mean is based on the area of which it covers) of the soil test values over all slopes and aspects of the farm

**d) Low slope** - based on the assumption that the entire farm will be fertilised based on rates calculated by soil test values of valley low and ridge low

**e) Aspect** (minus low slopes) – The farm would be split into three fertiliser block. South facing slopes (average of all south facing slopes), north facing slopes (average of all north facing slope), and low slopes (combined average of valley and ridge low)

**f) Aspect and slope** – The farm kept its delineation, each landscape group was fertilised using its mean Olsen P.

A fertiliser econometric model can be used to determine the most economically viable fertiliser application, which takes into account the relationship between soil fertility, production levels, and cost surrounding fertiliser application. It is therefore, difficult to determine the most economical fertiliser application scenario for Blue Duck Station in the absence of such model. Nevertheless, it is well known that economic fertiliser gains are not linear. They reach a point of diminishing return, where by it is not economical to apply additional fertiliser to reach higher levels of soil fertility (Figure 5.3). For a soil with low fertility, the cost (c) of applying fertiliser is low, relative to the economic benefits (b) to the farm. For farms where soils fertility is initially high, the cost (c) of applying fertiliser is high; relative to the economic benefits (b) gained. As soil fertility increases, so does the cost of raising pasture production levels, which reduces the potential profitability of fertiliser application (diminishing returns) (Edmeades, 2003b).

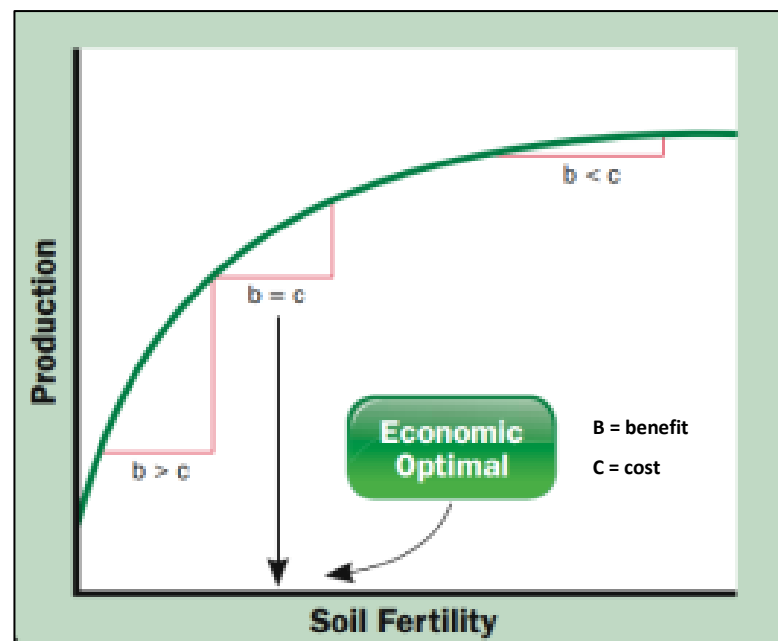

**Figure 5.3** Relationship between production and soil fertility, showing the economical optimal (Edmeades, 2002b)

### 5.3.3 Potential for differential fertiliser application

Previous research by Gillingham, *et al.*, (1998) (1999) (2003a) has shown that differential fertiliser application can help achieve maximum fertiliser efficiency. Differentially fertilising a North Island hill country farm can increase the stocking rate by 0.5 su/ha and improve its economic return by 7.5%. Gillingham *et al.*, (1998) suggested the most efficient fertiliser policy for hill country farms is high phosphorus fertiliser application on south facing, and moist north facing slopes. They also suggested applying limited phosphorus to steep north facing slopes. Gillingham, (2001) supported the process of differential fertiliser application, demonstrating that capital phosphorus fertiliser on easy slopes, and nitrogen fertiliser on both north and south steep slopes would improve economic returns by 34% than a blanket application of low level P fertiliser, and 8.1% better than a blanket application of high P fertiliser.

Gillingham, (1999) demonstrated the cost of producing one stock unit on various slope classes. On steep slopes it took 1.1kg/P/yr to produce one stock unit, 0.7 Kg/P/ha on easy slopes, and only 0.3Kg/P/ha on flats. The problem with focusing on the influence of slope to produce a stock unit, is that Blue Duck Station is dominated by steep slopes. Blue Duck Station has only 33ha of flat slopes and 75 ha of easy slope, with steep slopes occupying 153.5 ha (over half of the farm). Therefore, the option of only fertilising low slopes would leave 153.5 ha of land with an Olsen P level below 10, which, due to the propensity of pasture under an Olsen P level of 10 to decrease in pasture quality (Clark, *et al.*, 1990, Dodd & Ledgard, 1999), would be poor fertiliser management.

#### *a) P fertiliser recommendations*

Soil chemical properties of Blue Duck Station follow trends produced by Gillingham, *et al.*, (1998) (1999) (2003a) (2001). Southern facing aspect had the lowest Olsen P levels, valley low and north facing medium had the highest Olsen P levels, and north facing steep slopes and ridge low slopes were between the

two levels. The six scenarios in Table 5.3 were created to recommend fertiliser applications.

Sample scenarios a) medium slope b) averages of all data c) weighted average, and d) low slope, offer similar cost to the farmer (Table 5.3). The fertiliser recommendations were based on the cost to raise the mean Olsen P of the scenario to the optimal Olsen P level of 22. Averaging the data meant that much of the sample sensitivity was lost. The high Olsen P levels of north facing medium slopes and ridge low slopes overestimated the farms average Olsen P, causing the areas to be under-fertilised. The low Olsen P levels of the southern slopes underestimated the farm, recommending P application which cause over-fertilising.

Sampling scenario e) was a recommendation based on an average of each aspect class (Table 5.3). The recommended fertiliser cost for scenario e) was \$53,207, the third lowest fertiliser option. Though fertiliser costs are not the lowest for this scenario, it acknowledges the differences in Olsen P values between south facing aspects and north facing aspects. Scenario e) applies 63% of the recommended total P fertiliser to the nutrient deficient south facing aspects and the remaining 37% of fertiliser on the higher Olsen P level north facing slopes.

The most detailed mosaic of application rates occurs when the farm was split into fertiliser blocks based on slope, aspect and elevation (scenario f). Table 5.3 displayed notable differences in fertiliser cost between south facing slopes, north facing slopes, north facing medium slopes, ridge low and valley low. The low Olsen P values (6.7) of the south facing slopes can lead to a depression in pasture production if not raised, making it a priority for south facing slopes to receive fertiliser. Nutrient transfer to north facing steep slopes is limited; therefore natural soil P increases are unlikely. Applying fertiliser to these north facing steep slopes will lift the current Olsen P value (10.4) and increase clover vigour and subsequent nitrogen fixation due to Subterranean clover presence (Lucas, *et al.*, 2010). Fertiliser additions to flat ridge tops would benefits soil fertility, by raising

its current Olsen P of 10.2. There is limited benefit in applying fertiliser to north medium slopes and flat valley floors as Olsen P is near optimal for this environment and stock transfer will continue to add nutrients to these areas.

If cost was not a limiting factor, scenario f) would achieve the most economical increase to pasture production. The landscape units would discourage over-fertiliser application to areas with high Olsen P values, and under-fertiliser application to sites with low Olsen P values. If the farm experienced economic restraints, the application of fertiliser to south facing slopes, north facing steep slopes and ridge low would still discourage incorrect fertiliser application, due to otherwise misleading sampling regime (however, only saving \$2800).

*b) Sulphur fertiliser recommendations*

Fertiliser recommendations are not heavily weighted on sulphate sulphur levels because of its high mobility in the soils. Therefore, organic sulphur is the predominant indicator of soil S needs. Organic sulphur, and therefore fertiliser recommendation, is based on a soil's ability to reach a steady state concentration of organic sulphur. Brown soils reach a steady-state concentration in organic sulphur levels of between 11-32 ppm (Edmeades, *et al.*, 2005). Edmeades, *et al.*, (2005) suggested that if organic sulphur levels are below 10, fertiliser S should be applied immediately for pasture maximisation. Organic sulphur levels at Blue Duck Station are predominantly below 10, therefore, it is recommended they receive an initial application to achieve an organic sulphur level of 10-12. Once an organic sulphur level of 10–12 is achieved, organic S levels will be enough to facilitate adequate annual mineralisation to reach sulphur requirements for pasture maximisation. Yearly application of 250kg/ha/yr of superphosphate will be sufficient to maintain yearly optimal S levels (Edmeades, Feyter, & O'Connor, 1984). In many cases, farm management plays a vital role in soil S levels and improved pasture management. Applying regular fertiliser will increase the soil's organic matter content, in turn increasing the organic sulphur pool, and allowing for more sulphate sulphur to become available (Edmeades, 2003a).

*c) Lime recommendations*

When lime is applied in conjunction with P fertiliser, both pasture maximisation and the increased P use-efficiency occurs (Edmeades, *et al.*, 1985). The optimal pH of most North Island mineral soil is between 5.8 and 6. To attain production maximisation irrespective of cost, best results are seen via low rate application of lime in conjunction with other fertilisers. Correct lime additions can restore nutrient deficiencies by 0 to 10%, whereas the addition of P can correct nutrient deficiencies by over 100%. Therefore, if the farm experiences economic restrictions, P fertiliser application should be given priority over lime (Edmeades, *et al.*, 1985).

*d) Concluding thoughts*

Little has changed to the native soil fertility status of Blue Duck Station, due to limited past fertiliser application and relatively low stocking rate (9.2 su/ha). The potential for soils to be in a development stage creates the need for high initial fertiliser application. Blue Duck Station should then be reassessed after the initial fertiliser application; to understand more about the phase of development, and the subsequent changes in soil chemical properties. (Gillingham, *et al.*, 1998).

## **5.4 Questioning traditional soil sampling methods**

Soil fertility is the foundation of productivity of any farm; therefore, a sampling protocol to measure soil fertility, and the variability within a farming system needs to be clearly stated (Edmeades D. , 2013). McLaren & Cameron, (1996) and Hill Laboratories, (2012b) and have outlined basic sampling protocol for hill country farms. Their sampling protocol suggests that farms should be delineated into one or more of the following factors; soil type, topography, land use, fertiliser history and healthy/unhealthy areas. Also giving an idea of the number of cores, transect sampling, areas to avoid and sample location.

Suggestions to sampling protocol have been made by some authors. However, there is a lack of Best Management Practise (BMP), with regard to a sampling protocol, specific to New Zealand hill country farms. An explicit BMP would allow



for comparable, replicable and consistent soil tests throughout New Zealand hill country farms, allowing for a better understanding of 'true' variability of soil fertility.

The result in Table 5.3 - various sampling scenarios – indicates the potential for varying sampling methods to influence farm fertiliser recommendations. If fertiliser recommendation were to be formulated using the north medium soil test, the farm would be predominantly under-fertiliser. Whereas using soil test for south facing medium slopes recommended fertiliser application that would over-fertilised the rest of the farm. Leading to the question of, what areas must be sampled to give the most accurate fertiliser recommendation. The Best Management Practice for soil sampling the Central North Island Hill Country would be to avoid sampling small exceptional areas like flat valley floors and flat ridge tops. Focusing sample regimes on a number of transects across northern and southern slopes would give more representative results.

### ***5.5 Potential for runoff recommendations***

The majority of phosphorus lost to waterways occurs within five to ten meters of river/stream systems (Morton & Roberts, 1999). When developing P runoff reduction strategies, it is important to understand that major sources of particulate phosphorus runoff to waterways are via stream bank erosion, and the major source of dissolved P is due to the direct application of phosphorus fertiliser to waterways (Edmeades, 2002).

Therefore, the BMP at Blue Duck Station to deal with phosphorus loss into waterways would be the reduction of direct fertiliser application to waterways, which would be achieved as a result of precision fertiliser application.

## **5.6 *Blue Duck Station and Ballantrae Hill Country***

### ***Research Station comparison***

Soil type and past fertiliser application differentiate Ballantrae Research Station and Blue Duck Station. Ballantrae is formed on tertiary sandstone, siltstone, and mudstone, while Blue Duck Station is formed on calcareous mudstone, overlain by tephra. Blue Duck Station has remained relatively unchanged since the conversion from native forest vegetation to pastoral land. Extensive past fertiliser application at Ballantrae has masked the natural variability of soil fertility, evening out natural variation due to slope, aspect and soil type (Table A5.1 and A5.2 - Appendix). The implication for fertiliser applications are that initial capital fertiliser for Blue Duck Station, should be varied based upon aspect differences, however, a reassessment may be required once the soils are in maintenance phase.

## **5.7 *Addressing the Research Hypothesis***

Due to the variability between aspect and slope classes I accept my hypothesis, concluding that landscape groups could be used to determine fertiliser recommendations to maximise productivity and minimise adverse environmental effects in hill country of the Central North Island. Variations in soil test data were evident when averaged across landscape groups of different aspects, slopes and elevations. However, the south facing slopes were significantly different from both the north medium and the valley low slopes.

## 5.8 *Recommended further work*

- The use of an econometric model to determine the most economically valuable fertiliser application
- Additional sampling to determine the amount of recorded variability was due to temporal changes. Would the soil test result be different if sampling was undertaken in winter?
- Whether it is practical to treat landscape groups differentially, based on statistical significance, or whether pragmatism outweighs significance,
- Practical limitations of differential fertiliser application, and associated costs/benefits, both economically and environmentally

## 5.9 *Summary and Conclusions*

Blue Duck Station was delineated into six soil-landscape groups (north facing medium slopes, north facing steep slopes, south facing steep slopes, south facing medium slopes, ridge low slopes and valley low slopes) based on slope, aspect, and elevation using GIS. Three replicate units were randomly selected from each of the six soil-landscape groups, which gave 18 study-sites in total. For each study site, one transect sample and five grid samples were collected. Olsen P, anion storage capacity, pH, sulphate-sulphur and cations (Mg, Na, K, Ca) were determined.

Mean Olsen P values were 10.4 on south facing steep slopes, 21.2 on north facing medium slopes, 7.5 on south facing steep slopes, 6.7 on south facing medium slopes, 16.4 on valley floors and 10.2 on flat ridge tops. Olsen P levels at Blue Duck Station were uniformly low, and the majority of landscape groups had a Blakemore, et al., (1987) Olsen P rating of 'very low' or 'low'. Results suggested that the higher Olsen P values on the north facing medium slopes and valley low slopes were due to positive nutrient transfer via animals who prefer to rest on the warmer and flatter areas. Sites with highest Olsen P values also had the greatest variability.

The ridges tops and valley floors of Blue Duck Station are mantled with tephra, and hill slopes are made up of calcareous soils derived predominantly from tertiary, sedimentary parent material. Positive allophane test and high ASC levels supported the presence of tephra on valley floor and flat ridge tops, while high calcium and magnesium were an indication of calcareous sedimentary soils on the steeper hills slopes.

Blue Duck Station has a limited history of past fertiliser application, reflected in the relationship between sulphate sulphur, Olsen P and ASC relationship, and limited differences between native vegetation and pastoral sites.

Soil pH was consistent, ranging between 5 and 5.4, and was rated by Blakemore *et al.*, (1987) as 'medium', apart from acidic soil under virgin native forest sites. The optimal pH of most North Island mineral soil is between 5.8 and 6, therefore the best pasture production results would be seen using low rate application of lime in conjunction with other fertilisers (Edmeades, *et al.*, 1985)

Organic sulphur and sulphate sulphur were rated as 'very low' (Blakemore *et al.*, 1987), on north facing steep slopes, and the rest of the landscape groups were rated 'low'. Organic sulphur is the predominant indicator of soil S needs. Due to the majority of organic sulphur levels at Blue Duck Station being below 10, initial fertiliser application is recommended to achieve an organic sulphur level of 12 (Edmeades, *et al.*, 2005). Once organic sulphur levels of 10–12 are achieved, sufficient organic S mineralisation will occur annually to meet the pasture S requirement to maximise production. Farm management plays a vital role in soil S levels. Applying regular fertiliser will increase the soils organic matter content, in turn increasing the organic sulphur pool, and allowing for more sulphate sulphur to become available (Edmeades, 2003a).

At Blue Duck Station, the application of higher rates of P fertiliser to south facing steep slopes and south facing medium slopes, with medium rates of P fertiliser addition to north facing steep slopes and ridge low slopes would optimise

fertiliser use. There is limited benefit in applying fertiliser to north medium slopes and flat valley floors as Olsen P is near optimal for this environment and stock transfer will continue to ass nutrients to these areas.

Fertiliser recommendations for Blue Duck Station were based on mean values averaged across the 3 study sites for each landscape group. However, high variability within a sample site (between grid and transect samples) was often greater than the range of variability across the means of all the landscape groups. Due to such large sample variability, difficulties arise when attempting to recommend accurate fertiliser regime, or sampling programs. The soil analysis results from a small number of samples should be treated with caution.

The Best Management Practice for soil sampling the Central North Island Hill Country would be to avoid sampling small exceptional areas like flat valley floors and flat ridge tops. Taking samples on a number of transects across northern and southern slopes would give more accurate results.

# Bibliography

- Abel, D. B., Abel, G., & Kirby, J. (1978). *The King Country - A Regional Resource Survey*. Victoria University, Geography. Wellington: The King Country Regional Development Council.
- AgResearch. (2012). *Why produce nutrient budgets*. Retrieved January 29, 2013, from Overseer: For on-farm management and decision support: <http://www.overseer.org.nz/>
- Ashman, M., & Puri, G. (2002). *Essential Soil Science; A Clear and Concise Introduction to Soil Science*. Great Britain: Blackwell Science.
- Barrow, N. (1987). Return of Nutrients by Animals. *Ecosystems of the World - Managed Grasslands Analytical Studies, 17B*, 181.
- Beef and Lamb New Zealand. (2010). *Economic Service Sheep and Beef Farm Survey - Taranaki/Manawatu*. Beef and Lamb New Zealand.
- Binoka, D. T. (2008). *Effect of Phosphorus Fertiliser on Soil Organic Matter Composition of Hill Country Pasture*. Hamilton: Waikato University.
- Blackmore, L., Ludecke, T., & Hogg, D. (1969). Fertilizer requirements of steepland soils in the Whanganui and Rangitikei Districts. *New Zealand Grassland Association*, (pp. 87-95).
- Blakemore, L. C., Searle, P., & Daly, B. (1987). *Methods For Chemical Analysis Of Soils*, (80). Wellington, Lower Hut, New Zealand: NZ Soil Bureau.
- Brady, N., & Weil, R. (2008). *The Nature and Properties of Soils*. New Jersey: Pearson Prentice hall.
- Brougham, R., Grant, D., & Godall, V. (1974). The occurrence of Browntop, in the Manawatu. *Proceedings of the New Zealand Grassland Association, 35*, 86-94.
- Burkitt, L., Moody, P., Gourley, C., & Hannah, M. (2002). A simple phosphorus buffering index for Australian soils. *Australian Journal of Soil Research, 40*, 497-513.
- Chang, S., & Jackson, M. (1957). Fractionation of Soil Phosphorus. *Soil Science, 84*(2), 133-144.

- Chapman, D., & Macfarlane, M. (1985). Chapter 3 - Pasture growth limitations in hill country and choice of species. In R. Bugress, & L. Brock, *Using Herbage Cultivars* (pp. 25-30). Palmerston North: New Zealand Grassland Association.
- Charlton, F., & Belgrave, B. (1992). The range of pasture species in New Zealand and their use in different environments. *Proceedings of the New Zealand Grassland Association*, 54, pp. 99-104. New Zealand Grassland Association.
- Clark, D., Ledgard, S., Lambert, M., O'Connor, M., & Gillingham, A. (1990). Long term effects of withholding phosphate application on North Island hill country: Economics. *Proceedings of the New Zealand Grassland Association*, 51, 29-34.
- Clinton, O. (1967). A Three Channel Flame Photometer for Soil Analysis. *New Zealand Journal of Science*, 1069-1075.
- Cornfort, S., & Frank, K. (2000). pH and Liming. *Nutrient management for agronomic Crops in Nebraska*, 51-58.
- Cornforth, I. (1980). *Soils and Fertilisers Soil Analysis Interpretation*. AgLink: Ministry of Agriculture and Fisheries.
- Cornforth, I. (1998). *Practical Soil Management*. Christchurch: Lincoln University Press.
- Cornforth, I. (nd). The fate of phosphorus fertiliser in soil. *Chemicals and Soils*.
- Dalal, R. (1977). Soil Organic Phosphorus. *Advances in Agronomy*, 29(3), 83-113.
- Daniel, T., Sharpley, A., & Lemunyon, J. (1998). Agricultural phosphorus and eutrophication: A symposium overview. *Journal of Environmental Quality*, 251.
- Dodd, M., & Ledgard, S. (1999). Long term (?) effects of withholding superphosphate application on North Island hill country: a 10 year update. *Proceedings of the New Zealand Grassland Association*, 61, 63-68.
- Edbrooke, S. (2005). *Geology of the Waikato Area*. Lower Hutt, New Zealand: Institute of Geological and Nuclear Sciences Limited.
- Edmeades, D. (2002). *The Fertiliser Review - Efficient Fertiliser Use*. Hamilton: aGKnowledge.

- Edmeades, D. (2003a). *Pasture Sulphur Requirements*. Hamilton: agKnowledge.
- Edmeades, D. (2003b). *The Fertiliser Review - The Economics of Fertiliser Use*. Hamilton: aGKnowledge.
- Edmeades, D. (2013, Feb 4). Sampling in New Zealand hill country. (M. Arrowsmith, Interviewer)
- Edmeades, D. C., Metherell, A. K., Waller, J. E., Roberts, A. H., & Morton, J. D. (2006). Defining the relationship between pasture production and soil P and the development of a dynamic P model for New Zealand pastures: a review of recent developments. (T. R. Zealand, Ed.) *New Zealand Journal of Agriculture*, *49*, 207-222.
- Edmeades, D., & O'Connor, M. (2003). Sodium requirements for temperate pastures in New Zealand: a review. *New Zealand Journal of Agricultural Research*, *46*, 37-47.
- Edmeades, D., Feyter, C., & O'Connor, M. (1984). Lime and phosphorus requirements for hill country yellow-brown earths. *Proceedings of the New Zealand Grassland Association*, 98-106.
- Edmeades, D., Metherell, A., Waller, J., Roberts, A., & Morton, J. (2006). Defining the relationships between pasture production and soil P and the development of a dynamic P model for New Zealand pastures: a review of recent developments. *New Zealand Journal of Agricultural Research*, *49*, 207-222.
- Edmeades, D., Pringle, R., Mansell, G., Shannon, P., Ritchies, J., & Stewart, K. (1985). Effects of lime on pasture production on soils in the North Island of New Zealand - Description of lime recommendation scheme. *New Zealand Journal of Experimental Agriculture*, *13*, 47-58.
- Edmeades, D., Thorrold, B., & Roberts, A. (2005). The diagnosis and correction of sulfur deficiency and the management of sulfur requirements in New Zealand pasture: A review. *Australian Journal of Experimental Agriculture*, *45*, 1205-1223.
- Fraser, S., & Vesely, E. (2011). Connecting North Island Hill country farmers nutrient requirements with soil mapping units. *New Zealand Soil News*, 36-37.



- Gillingham, A. (1978). *Phosphorus cycling in grazed, steep hill country*. Palmerston North: Massey University.
- Gillingham, A. (1987). Phosphorus Cycling in Managed Grasslands. *Ecosystems of the World - Managed Grasslands Analytical Studies, (17B)*, 173-184.
- Gillingham, A. G. (1980). Phosphorus uptake and return in grazed, steep hill pasture - Pasture production and dung litter accumulation. *N.Z Journal of Agricultural Research*, 23, 313-321.
- Gillingham, A. G. (2001). Precision Management Of Fertiliser Application To Pasture. *Proceedings of the First Australian Geospatial Information and Agriculture Conference* (pp. 534-541). Sydney: Geospatial Information and Agriculture.
- Gillingham, A. G., Maber, J., Morton, J., & Tuohy, M. (1999). Precise aerial fertiliser application on hill country. *Proceedings of the New Zealand Grassland Association* (pp. 221-226). Dunedin: New Zealand Grassland Association.
- Gillingham, A. G., Morton, J. D., & Gray, M. H. (2003a). The role of differential fertiliser application in sustainable management of hill pastures. *Proceedings of the New Zealand Grassland Association*, 65, p. 253.
- Gillingham, A., Gray, M., & Smith, D. (1998). Pasture response to phosphorus and nitrogen fertilisers on dry hill country. *Proceedings of the New Zealand Grassland Association*, 60, 135-140.
- Gillingham, A., Morton, J., & Gray, M. (2007). Pasture response to phosphorus and nitrogen fertilisers on East Coast hill country: total production from easy slope. *New Zealand Journal of Agricultural Research*, 50(3), 317.
- Gillingham, A., Morton, J., & Gray, M. (2008b). Pasture response to phosphorus and nitrogen fertilisers on east coast hill country: 2. Clover and grass production from easy slopes. *New Zealand Journal of Agricultural Research*, 51, 85-97.
- Gillingham, A., Morton, J., & Gray, M., & Roberts, A. (2008b). Pasture response to phosphorus and nitrogen fertilisers on east coast hill country: 3. Production from steep slopes. *New Zealand Journal of Agricultural Research*, 51, 425-437

- Gillingham, A., Sheath, G., Gray, M., & Webby, R. (2003b). Management and nitrogen fertiliser options for increased pasture productivity in dryland hill systems. *Legumes for dryland pastures* (pp. 43-50). Lincoln University: New Zealand Grassland Association.
- Grant, L., & Dudin, S. (2007). *Whole Farm Plan - Whakahoro Farm*. Taumarunui: Horizons Regional Council.
- Hart, M. R., Quin, B. F., & Nguyen, L. M. (2004, Nov/Dec). Phosphorus Runoff from Agricultural Land and Direct Fertilizer Effects: A Review. *Journal of Environmental Quality*, 33(6), 1954.
- Hewitt, A. (2009, March 1). *The most extensive soils*. Retrieved from Te Ara - the Encyclopedia of New Zealand: <http://www.TeAra.govt.nz/en/soils/4>
- Hewitt, A. E. (1998). *New Zealand Soil Classification* (3 ed.). Wellington: Manaaki Whenua Press.
- Hill Laboratories. (2012a). *Soil Phosphorus Tests*. Retrieved June 26, 2012, from Technical notes: <http://www.hill-laboratories.com/file/fileid/17695>
- Hill Laboratories. (2012b). *Technical Notes - Sampling options for pastoral farms*. Hamilton: Hill Laboratories.
- Hill Laboratories. (2012c). *Technical Notes - Soil tests and interpretation*. Retrieved from Hill Laboratories - Better testing better results: <http://www.hill-laboratories.com/file/fileid/15530>
- Hill Laboratories. (nd). *Laboratory tests for soil sulphur*. Retrieved from Technical Notes: <http://www.hill-laboratories.com/file/fileid/18720>
- Horizons Regional Council. (2007). *What is in a whole farm plan*. Horizons Regional Council.
- Jenny, H. (1941). *Factors of soil formation; a system of quantitative pedology*. New York: McGraw Hill.
- Lambert, M., & Grant, D. (1980). Fertiliser and lime effects on some southern North Island hill pastures. *New Zealand Journal of Experimental Agriculture*, 8, 223-229.
- Lambert, M., Clark, D., & Litherland, A. (2004). Advances in pasture management for animal productivity and health. *New Zealand Veterinary Journal*, 311-319.

- Lambert, M., Clark, D., Mackay, A., & Costall, D. (2000). Effects of fertiliser application on nutrient status and organic matter content of hill soils. *New Zealand Journal of Agricultural Research*, 43, 127-138.
- Lambert, M., Clark, D., Grant, D.A, Costall, D., Fletcher, R.H (1983). Influence of fertiliser and grazing management on North Island moist hill country. I. Herbage accumulation. *New Zealand journal of agricultural research* 26, 95-108.
- Lambert, M., Mackay, A., & Costall, D. (1998). Long-term fertiliser application and fertility of hill soils. *Proceedings of the New Zealand Grassland Association*, 60, 69-67.
- Landcare Research . (2012). *Soil Orders from the New Zealand Soil Classification (NZSC)*. Retrieved December 24, 2012, from Landcare Research: [http://soils.landcareresearch.co.nz/contents/SoilNames\\_NZSoilClassification\\_SoilOrders.aspx](http://soils.landcareresearch.co.nz/contents/SoilNames_NZSoilClassification_SoilOrders.aspx)
- Ledgard, S., Johnston, T., Edmeades, D., & Wheeler, D. (1991). Soil nutrient status of the Bay of Plenty region and the implications to pasture productivity and fertiliser requirements. *Proceedings of the New Zealand Grassland Association*, 53, 175-179.
- Ledgard, S., Williams, P., Broom, F., Thorrold, B., Wheeler, D., & Wills, V. (1999). *A nutrient budgeting model for pastoral farming, wheat, Potatoes, apples and kiwifruit*. Retrieved from OVERSEER: <http://www.overseer.org.nz/LinkClick.aspx?fileticket=HbqZSLBp-eE%3D&tabid=81>
- Lee, R., Cornforth, I., Edmeades, D., & Watkinson, J. (1991). A comparative Study of MAF (Ruakura) and DSIR Land Resources Soil Analysis Results. *New Zealand Journal of Agricultural Research*.
- Lemunyon, J. L., & Daniel, C. T. (2002). Quantifying phosphorus losses from agricultural system. *Journal of Soil and Water Conservation*, 57(6), 399.
- Lognanathan, P., Hedley, M., Gregg, P., & Currie, L. (1996). Effect of phosphate fertiliser type on the accumulation and plant availability of cadmium in grassland soils. *Nutrient Cycling in Agroecosystems*, 46(3), 167-178.

- Lucas, R., Smith, M., Jarvis, P. M., & Moot, D. (2010). Nitrogen fixation by subterranean and White clover in dryland cocksfoot pastures. *Proceedings of the New Zealand Grassland Association*, 72, 141-146.
- Lynn, I., Manderson, A. P., Harmsworth, G., Eyles, G., Douglas, G., Mackay, A., et al. (2009). *Land Use Capability Survey Handbook - A New Zealand handbook for the classification of land 3rd ed.* Hamilton: AgResearch.
- Lowe, D.J. 2010. Quaternary volcanism, tephras, and tephra-derived soils in New Zealand: an introductory review. In: Lowe, D.J.; Neall, V.E., Hedley, M; Clothier, B.; Mackay, A. 2010. Guidebook for Pre-conference North Island, New Zealand 'Volcanoes to Oceans' field tour (27-30 July). 19th World Soils Congress, International Union of Soil Sciences, Brisbane. Soil and Earth Sciences Occasional Publication No. 3, Massey University, Palmerston North, pp. 7-2
- Mackay, A., & Lambert, M. (2011). Long-term changes in soil fertility and pasture production under no, low and high phosphorus fertiliser inputs. *Grass Land Publication*, 37-41.
- McCull, R. H., & Gibson, A. R. (1979). Downslope movement of nutrients in hill pasture, Taita, New Zealand; Effect of season, sheep grazing and fertiliser. *New Zealand Journal of Agricultural Research*, 22, 151-161.
- McCull, R. H., White, E., & Gibson, A. R. (1977). Phosphorus and nitrate run-off in hill country pasture and forest catchments. *New Zealand Journal of Marine and Freshwater Research*, 11, 729-744.
- McCraw, J. (1974). Soils of the Northern King Country. *Proceedings of the New Zealand Grassland Association*, 35, 15-21.
- McDowell, R. W., Littlejohn, R. P., & Blennerhassett, J. D. (2010). Phosphorus fertiliser form affects phosphorus loss to waterways: a paired catchment study. *Soil Use and Management*, 26, 365-373.
- Mclaren, R., & Cameron, K. (1996). *Soil Science, Sustainable production and environmental protection.* Victoria: Oxford Press.
- McLaughlin, M., Tiller, K., & Naidu, R. S. (1996). Review: the behaviour and environmental impacts of contaminants in fertilizers. *Australian Journal of Soil Research*, 34, 1-54.

- Meneer, J. C., Ledgard, S. F., & Gillingham, A. G. (2004). *Land Use Impacts on Nitrogen and Phosphorous Loss and Management Options for Intervention*. Environment Bay of Plenty.
- Milne, J. (1991). *Soil Description Handbook*. Lower Hutt: DSIR Land Resource.
- Moody, P. (2007). Interpretation of a Single-point P Buffering Index for Adjusting critical levels of the Colwell soil P test. *Australian Journal of Soil Research*, 45, 55-62.
- Morton, J. (2012). *The Altum Examiner - The Science of Sulphur*. Tauranga: Altum.
- Morton, J., & Roberts, A. (1999). *Fertiliser use on New Zealand sheep and beef farms: the principles and practice of soil fertility and fertiliser use on New Zealand sheep and beef farms*. Auckland: New Zealand Fertiliser Manufacturers' Research Association.
- Murphy, J., & Riley, J. (1962). A modified single solution method for the determination of phosphate in natural waters. *Analytical Chemistry*.
- Olsen, S., Cole, C., Watanabe, F., & Deon, L. (1954). Estimation of available phosphorus in soils by extraction with sodium bicarbonate. *U.S. Department of Agriculture Circular*, p. 939.
- Orbell, G. E. (1974). *Soils of the Waikato Coromandel King Country Region*. Wellington: Soil Bureau Publication, Government Printer.
- Parfitt, R., Mackay, A., Ross, D., & Budding, P. (2009). Effects of soil fertility on leaching losses of N, P and C in hill country. *New Zealand Journal of Agricultural Research*, 52, 69-80.
- Perrott, K. W., Sarathchandra, S. U., & Dow, B. W. (1992). Seasonal and Fertilizer Effects on the Organic Cycle and Microbial Biomass in a Hill Country Soil under Pasture. *Australian Journal of Soil Research*, 30(3), 383-394.
- Pollock, K. (2011). *King Country region - Facts and figures*. Retrieved December 24, 2012, from Te Ara - the Encyclopedia of New Zealand: <http://www.teara.govt.nz/en/king-country-region/13>
- Quin, B. (2010). *Improving the Utilisation of Phosphorus in New Zealand Agriculture*. Retrieved December 22, 2012, from Group one - Optimising Nurtient Efficiency:

<http://www.groupone.co.nz/Quinformation/QuinformationLibrary/ImprovingtheUtilisationofPhosphorus.aspx>

- Radcliffe, J. E., & Lefever, K. (1987). Aspect influences on pasture microclimate at Coopers Creek, North Canterbury. *New Zealand Journal of Agricultural Research*, 24, 55-66.
- Radcliffe, J., & Baars, J. (1987). The productivity of Temperate Grasslands. *Ecosystems of the world - Managed Grasslands Analytical Studies*, (17b), 14.
- Ratray, P. (1987). Sheep production from managed grasslands. *Ecosystems of the World - Managed grasslands analytical studies*, (17b), 115.
- Rayment, G. E., & Lyons, D. J. (2011). *Soil Chemical Methods: Australasia*. Victoria: CSIRO.
- Rowarth, J., & Gillingham, A. (1990). Effects of withholding fertiliser on pasture production and phosphate cycling in hill country. *Proceedings of the New Zealand Grassland Association*, 51, pp. 17-20.
- Saggar, S., Mackey, A. D., Hedley, M. J., Lambert, M. G., & Clark, D. A. (1990). A Nutrient-Transfer Model to Explain the Fate of Phosphorus and Sulphur in a Grazed Hill-Country Pasture. *Agriculture, Ecosystems and Environment*, 295-315.
- Saunders, W., Sherrell, C., & Gravett, I. (1987). A new approach to the interpretation of soil tests for phosphate response by grazed pasture. *New Zealand Journal of Agricultural Research*, 30, 67-77.
- Sigua, C., Myer, O., Coleman, S., Mackowiak, C., Adjei, M., Chase, C., et al. (2011). Regional Distribution of Soil Phosphour across Congregation-Grazing Zones of Forage-Based Pastures with Cow-Calf Operations in Florida. *Journal of Envionrmental Protection*, 2, 408-417.
- Sinclair, A. G., Johnstone, P. D., Smith, L. C., Roberts, A. H., O'Connor, M. B., & Morton, J. D. (1997). Relationship between pasture dry matter yeild and soil Olsen P from a series of long-term field trails. *New Zealand Journal of Agricultural Research*, 40, 559-567.
- Singer, J. M., & Munns, N. D. (2006). *Soils, an introduction*. New Jersey: Pearson Prentice Hall.

- Sparling, G., & Schipper, L. (2004). Soil quality monitoring in New Zealand: trends and issues arising from a broad-scale survey. *Agriculture Ecosystems and Environmental*, 104, 545-552.
- Stantiall, J. (2006). *Precision Aerial Application of Fertiliser - Literature Review*. Manawatu: Meat and Wool New Zealand.
- Stewart, J., & Tiessen, H. (1987). Dynamics of soil organic phosphorus. *Biogeochemistry*, 4, 41-60.
- Suckling, F. (1959). Pasture management trials on unploughable hill country at Te Awa. III. Results for 1959-69. *New Zealand Journal of Experimental Agriculture*, 3, 351-436.
- Thompson, L., & Troeh, F. (1973). *Soils and soil fertility*. USA: McGraw-Hill.
- Thorrold, B., K.F. O., & White, J. (1985). Management influences on sheep behaviour, dung distribution and soil phosphate. *New Zealand Grassland Association*, 46, pp. 127-134.
- Truog, E. (1948). Lime in relation to Availability of Plant Nutrients. *Soil Science*, 65(1), 1-8.
- Waltkinson, J., & Kear, M. (1994). High Performance Ion Chromatography measurement of Sulphate in 20mM Phosphate extracts of soil. *Communications in Soil Science and Plant Analysis*, 25, 1015-1033.
- Watanabe, F., & Olsen, S. (1965). Test of an ascorbic acid method for determining phosphorus in water and NaHCO<sub>3</sub> extracts from soil. *Soil Science Society of America Proceedings*, 29, 677-678.
- Watkinson, J., & Kear, M. (1996). Sulphate and mineralisable organic sulphur in pastoral soils on New Zealand. 2. A soil test for mineralisable organic sulphur. *Australian Journal of Soil Research*, 34, 405-412.
- Watkinson, J., & Perrot, K. (1990). A new soil test for sulphate and mineralisable organic sulphur. *The New Zealand Manufacturers Research Association Conference*, (pp. 188-198).
- White, R. (1987). *Introduction to the Principles and Practice of Soil Science*. Oxford: Blackwell Scientific Publications.

Williams, P., & Haynes, R. (1990). Influence of improved pastures and grazing animals on nutrient cycling within New Zealand soils. *New Zealand Journal of Ecology*, 1.

Williams, P., & Haynes, R. (1999). Influence of stock camping behaviour on the soil microbiological and biochemical properties of grazed pastoral soils. *Biology, Fertility and Soils*, 28, 253-258.





# Appendix

## Waikato Laboratory pH analysis

**Table A4.1** pH values obtained through chemical analysis at Waikato University laboratory

Sample	Transect	Grid 1	Grid 2	Grid 3	Grid 4	Grid 5
NS1	5.804	5.213	5.44	5.57	5.195	5.657
NS2	5.665	5.403	5.78	5.568	5.572	5.8343
NS3	5.636	5.554	5.718	5.385	5.553	5.396
NM1	5.175	5.394	5.391	5.437	5.398	5.309
NM2	5.205	5.48	5.532	5.223	5.125	5.671
NM3	5.346	5.572	5.334	5.233	5.371	5.631
SS1	5.401	5.467	5.326	5.489	5.335	5.6
SS2	5.453	5.793	5.475	5.698	5.515	5.456
SS3	5.748	5.759	5.953	5.305	5.798	5.585
SM1	5.477	5.379	5.205	5.49	5.635	5.463
SM2	5.876	5.695	5.707	5.449	5.864	5.638
SM3	5.543	5.659	5.67	5.587	5.463	5.804
VL1	5.581	5.733	5.572	5.655	5.601	5.874
VL2	5.365	5.178	5.094	5.268	5.156	5.508
VL3	5.194	5.783	5.302	4.977	5.249	5.34
RL1	5.532	5.513	5.344	5.339	5.199	5.296
RL2	5.571	5.695	5.455	5.4	5.613	5.857
RL3	5.382	5.128	5.561	5.652	5.657	5.419

## Comparative data between Blue Duck Station and Ballantrae Hill Country Research Station

Soil chemical properties of Blue Duck Station were compared with Ballantrae Hill Country Research Station, a hill country farm in the Tararua District, with similar slope and aspect (Table 5.4)

**Table A5.1** Aspect effect on soil chemical properties of Ballantrae Hill-country Research Station and Blue Duck Station. Samples were from all aspects combined, and are taken at the top 75 mm of soil (Ballantrae data from; Lambert, et al., 2000).

Soil Chemical Properties	Study Site	Aspect category	
		North	South
Olsen P	Blue Duck Station	15.9a	7.1b
	Ballantrae Mixed Fertiliser <sup>1</sup>	13.4	13.4
Anion storage capacity	Blue Duck Station	50a	59b
	Ballantrae Mixed Fertiliser <sup>1</sup>	20.5a	30.5b
Soil pH	Blue Duck Station	5.3	5.4
	Ballantrae Mixed Fertiliser <sup>1</sup>	5.35	5.36
Organic sulphur	Blue Duck Station	4.7a	6.1b
	Ballantrae Mixed Fertiliser <sup>1</sup>	3.91	3.68
Sulphate sulphur	Blue Duck Station	6.4	6.3
	Ballantrae Mixed Fertiliser <sup>1</sup>	5.8	5.4
Potassium	Blue Duck Station	14.9a	11.2b
	Ballantrae Mixed Fertiliser <sup>1</sup>	9.3	9.4
Calcium	Blue Duck Station	6.1a	4.9b
	Ballantrae Mixed Fertiliser <sup>1</sup>	6.2	6.0
Magnesium	Blue Duck Station	32.7a	26.7b
	Ballantrae Mixed Fertiliser <sup>1</sup>	28.4	26.1
Sodium	Blue Duck Station	6.4a	5.4b

Represents the bulking of samples from varying aspects and fertiliser application rates, to give samples which are differentiated by slope classes

**Table A5.2** Slope effect on soil chemical properties of Ballantrae Hill-country Research Station and Blue Duck Station. Samples were from all aspects combined, and are taken at the top 75 mm of soil (Lambert, *et al.*, 2000, Mackay & Lambert, 2011).

Soil Chemical Properties	Study Site	Slope Class (degrees)		
		Low	Medium	High
Olsen P	Blue Duck Station	13.3a	13.4a	9b
	Ballantrae - No fertiliser	4.5	4.5	3.5
	- Low fertiliser	17.5	20	15
	- High fertiliser	60	42.5	29.5
	Ballantrae Mixed Fertiliser <sup>1</sup>	16.3a	12.3b	12.8b
ASC	Blue Duck Station	75.2a	59.8b	45.3c
	Ballantrae Mixed Fertiliser <sup>1</sup>	25.5	26.9	24.2
Soil pH	Blue Duck Station	5.3a	5.3a	5.4b
	Ballantrae Mixed Fertiliser <sup>1</sup>	5.43a	5.37ab	5.36b
Organic sulphur	Blue Duck Station	9.1a	6b	5b
	Ballantrae Mixed Fertiliser <sup>1</sup>	4.76a	3.91b	2.97c
Sulphate sulphur	Blue Duck Station	17.4a	17.7b	5.1c
	Ballantrae - No fertiliser	15	17.5	12.5
	- Low fertiliser	15	15	15
	- High fertiliser	12.5	15.2	10
	Ballantrae Mixed Fertiliser <sup>1</sup>	6.5	5.2	4.9
Potassium	Blue Duck Station	14.4a	13.9b	12.2b
	Ballantrae - No fertiliser	8.3	8.7	6.6
	- Low fertiliser	8.7	9.13	6.6
	- High fertiliser	13.3	8.7	4.15
	Ballantrae Mixed Fertiliser <sup>1</sup>	12.2a	9.2b	7c
Calcium	Blue Duck Station	4.6a	4.6a	6.5b
	Ballantrae - No fertiliser	3.01	2.1	4.2
	- Low fertiliser	5.6	5.6	3.01
	- High fertiliser	5.5	9.1	7
	Ballantrae Mixed Fertiliser <sup>1</sup>	6.9	6.1	6.2
Magnesium	Blue Duck Station	21.3a	25.4b	34c
	Ballantrae - No fertiliser	25	18.8	19.2
	- Low fertiliser	22.8	20.8	17.6
	- High fertiliser	17.6	14.4	15.7
	Ballantrae Mixed Fertiliser <sup>1</sup>	31.3a	25.5b	25.9c
Sodium	Blue Duck Station	4.9a	5.6b	6.1b

1 Represents the bulking of samples from varying aspects and fertiliser application rates, to give samples which are differentiated by slope classes

## Sample analysis data

Unit	ASC	Ca	K	Mg	Na	OS	P	pH	SO4
<b>NM1</b>	<b>42.556</b>	<b>5.4</b>	<b>18</b>	<b>35.5</b>	<b>4.9</b>	<b>5.529</b>	<b>49.45</b>	<b>5.05</b>	<b>4.516</b>
NM1 - G1	35.834	4.9	17.3	28.5	4.9	3.777	16.64	5.22	3.574
NM1 - G2	32.809	6.3	22.6	41.7	4.6	3.719	44.54	5.09	7.68
NM1 - G3	30.625	6.3	20.7	35.6	5.6	4.667	29.59	5.24	4.438
NM1 - G4	41.38	3.8	12.1	22.1	4.8	4.134	14.31	5.13	3.267
NM1 - G5	33.314	6.5	17.5	33.7	5.3	4.256	23.07	5.13	2.921
NM2	53.969	4.6	21	21.8	4.6	5.294	20.59	5.21	9.982
NM2 - G1	48.389	6.3	31.2	35.8	5.8	4.166	31.14	5.42	9.245
NM2 - G2	63.981	5.1	21.7	21.6	5.8	6.227	13.61	5.43	8.729
NM2 - G3	54.79	4.2	10.5	18.1	5.5	3.302	11.8	5.26	8.828
NM2 - G4	64.145	3.5	22.3	18.5	5.1	5.786	24.35	5.19	10.537
NM2 - G5	38.87	6.6	19.6	38.2	7.6	4.297	27.08	5.43	8.797
NM3	82.181	3.4	7.5	16.4	8	7.941	13.27	5.26	12.503
NM3 - G1	78.313	3.5	12.2	18.3	8	8.757	13.63	5.43	9.267
NM3 - G2	66.655	5	11.1	20.4	8.5	6.394	11.74	5.28	9.69
NM3 - G3	81.977	2.5	7.3	12.8	8	8.449	9.88	5.23	11.103
NM3 - G4	85.641	3.8	11.2	20.7	7.6	9.086	14.77	5.26	12.355
NM3 - G5	86.14	2.4	9	14.2	9.2	9.434	12.43	5.3	14.033

Unit	ASC	Ca	K	Mg	Na	OS	P	pH	SO4
<b>SS1</b>	<b>69.68</b>	<b>3</b>	<b>8.3</b>	<b>19.3</b>	<b>5.6</b>	<b>8.493</b>	<b>5.02</b>	<b>5.33</b>	<b>5.844</b>
SS1 - G1	72.665	2.2	10.8	13.9	3.2	10.349	3.3	5.5	12.774
SS1 - G2	46.958	4.3	10.3	27.1	6.7	6.846	4.54	5.23	2.634
SS1 - G3	68.519	3.2	11.1	17.5	4.1	8.498	3.71	5.41	7.378
SS1 - G4	54.256	3.5	8.8	19.2	5.6	7.585	5.32	5.33	5.272
SS1 - G5	64.704	4.4	7.8	16.3	5.7	9.347	4.55	5.42	6.89
SS2	55.831	6	12	31.9	6	4.537	12.63	5.21	6.926
SS2 - G1	49.782	6.6	11.1	28.4	6.7	3.185	6.87	5.48	4.851
SS2 - G2	58.856	6.1	14.1	29.4	5.4	3.961	9.46	5.25	7.517
SS2 - G3	58.016	6.4	9.6	29.9	6.8	3.409	6.98	5.53	4.446
SS2 - G4	44.572	7.2	9.8	37.9	7	2.772	8.72	5.33	4.59
SS2 - G5	40.203	7.2	7.1	40.4	6.5	2.806	7.04	5.25	2.837
SS3	56.103	5.8	8.3	27.9	6.3	5.928	6.99	5.51	6.021
SS3 - G1	69.561	3.9	7.2	16.8	5.5	8.953	5.73	5.46	4.441
SS3 - G2	66.771	5.2	6.7	18.9	6.2	8.002	5.05	5.61	7.974
SS3 - G3	39.827	6.4	13	41.4	4.8	4.767	9.73	5.32	2.694
SS3 - G4	47.953	6.6	23.3	44.1	5.9	8.099	6.59	5.54	7.115
SS3 - G5	32.363	8.1	20.3	41	5.8	5.384	23.32	5.31	4.552

Unit	ASC	Ca	K	Mg	Na	OS	P	pH	SO4
<b>SM1</b>	<b>85.481</b>	<b>4</b>	<b>11.3</b>	<b>20</b>	<b>5</b>	<b>16.363</b>	<b>8.59</b>	<b>5.26</b>	<b>4.988</b>
SM1 - G1	68.74	3.9	16.2	23.9	4.5	9.651	8.7	5.24	8.669
SM1 - G2	59.878	3.5	16.3	20.7	4.1	8.126	6.73	5.14	7.179
SM1 - G3	85.317	4	12.9	21	4	7.481	5.21	5.4	10.175
SM1 - G4	79.408	3.8	17.1	21.7	4.4	9.882	11.36	5.29	18.691
SM1 - G5	96.805	4.4	11.7	20.8	3.8	12.664	6.35	5.46	14.632
SM2	58.495	6.3	10.3	38.9	5.5	3.752	5.01	5.66	4.814
SM2 - G1	62.159	4.4	5.9	25.5	4.7	2.044	4.22	5.55	5.481
SM2 - G2	60.66	5.3	7.7	35.7	4.8	3.459	3.3	5.56	4.547
SM2 - G3	38.677	5.5	12.2	50.1	4.9	3.331	5.48	5.35	2.738
SM2 - G4	67.488	5.5	10.3	27.8	6.7	4.356	3.82	5.66	4.164
SM2 - G5	39.343	6	18.3	39.5	5.6	3.53	8.03	5.41	2.226
SM3	48.606	4.2	8.7	20.7	6	2.987	6.73	5.32	4.855
SM3 - G1	40.035	4.8	5.8	24.1	6.1	2.141	6.73	5.4	3.159
SM3 - G2	69.779	3	19.9	16.6	3.7	6.912	9.89	5.06	12.667
SM3 - G3	56.355	3.4	6.5	16	5.3	4.028	7.34	5.41	5.843
SM3 - G4	50.785	3.8	7.2	18.8	4.9	3.437	7.07	5.24	3.689
SM3 - G5	59.731	4.1	7.8	19.5	5.2	4.327	6.29	5.38	4.219

Unit	ASC	Ca	K	Mg	Na	OS	P	pH	SO4
<b>NS1</b>	<b>34.46</b>	<b>8.5</b>	<b>19.2</b>	<b>48.1</b>	<b>5.4</b>	<b>4.261</b>	<b>12.38</b>	<b>5.57</b>	<b>5.309</b>
NS1 - G1	44.905	6.4	15.1	34.8	6.1	6.721	16.97	5.22	8.609
NS1 - G2	34.792	8.6	18.3	50.6	6.6	4.478	9.02	5.4	5.435
NS1 - G3	34.958	7.3	15.6	40.3	5.7	4.695	14.12	5.42	6.989
NS1 - G4	40.926	6.3	19.7	34.1	5.5	5.872	12.67	5.24	5.96
NS1 - G5	33.797	10	13	43.5	6.4	4.821	8.71	5.53	3.795
NS2	38.019	7.5	10.8	36	8	2.057	6.8	5.45	5.8
NS2 - G1	34.322	9	6.7	33.6	8.3	0.938	5.66	5.38	3.828
NS2 - G2	36.002	10	9.8	42.6	8.5	2.26	4.82	5.56	1.834
NS2 - G3	38.691	7.5	11.9	41.9	5.6	3.92	6.06	5.43	4.545
NS2 - G4	43.228	6.7	12.6	38.4	5.8	1.569	5.79	5.38	5.761
NS2 - G5	26.256	10.5	12.2	44.5	7.3	1.055	5.15	5.53	5.06
NS3	33.015	5.7	14	39.3	5.5	2.671	14.11	5.45	3.756
NS3 - G1	32.348	6.6	11.4	48.8	6	3.944	7.72	5.4	1.695
NS3 - G2	28.352	6.4	11	39.6	6.5	2.315	6.28	5.36	2.219
NS3 - G3	34.68	6.4	15.5	37.8	6.1	3.641	15.73	5.37	2.817
NS3 - G4	34.18	6.3	14.7	31.8	7.5	4.861	28.47	5.1	3.562
NS3 - G5	30.35	6.6	9.6	38.5	5.8	3.731	7.18	5.28	2.126

Uni	ASC	Ca	K	Mg	Na	OS	P	pH	SO4
<b>VL1</b>	<b>90.164</b>	<b>3.8</b>	<b>12.4</b>	<b>14.3</b>	<b>4.2</b>	<b>14.533</b>	<b>14.25</b>	<b>5.39</b>	<b>33.59</b>
VL1 - G1	94.356	5.2	13.7	17.3	4.4	13.407	12.4	5.5	41.921
VL1 - G2	89.325	5.7	10.5	17.2	3.9	15.66	17.51	5.53	29.088
VL1 - G3	90.164	5	14.6	16.8	3.8	15.061	13.36	5.55	39.061
VL1 - G4	94.507	5.4	8.4	13.8	4.4	12.188	14.24	5.37	27.685
VL1 - G5	94.015	6.1	6.6	14	4.5	13.955	11.27	5.52	36.739
VL2	69.036	4.5	14.5	20.9	4.2	9.843	20.29	5.15	11.696
VL2 - G1	70.378	3.5	18.5	15.9	3.7	9.427	20.15	5.04	12.74
VL2 - G2	64.677	4.3	19.2	23.8	3.7	7.889	35.6	5	17
VL2 - G3	82.283	3.3	10.7	11.7	5	13.325	13.94	5.19	9.947
VL2 - G4	63.503	5.3	25.1	27.4	4	6.687	44.15	5.14	18.037
VL2 - G5	61.491	4.5	15.3	22.4	4.3	6.835	18.74	5.12	8.779
VL3	92.21	2.2	7.2	9.8	5	10.978	7.89	5.22	14.593
VL3 - G1	97.133	4.8	11.8	17.6	7.1	10.597	8.72	5.53	14.741
VL3 - G2	92.538	3.6	12.3	13.5	4.6	10.807	8.27	5.23	19.266
VL3 - G3	94.672	1.8	8.3	9.3	4.5	10.575	9.29	5.04	14.182
VL3 - G4	88.763	2.9	12.4	13.3	4.3	10.954	10.41	5.14	16.604
VL3 - G5	86.63	2.5	9.9	14.8	7.4	8.539	13.91	5.01	21.029

Unit	ASC	Ca	K	Mg	Na	OS	P	pH	SO4
<b>RS1</b>	<b>55.342</b>	<b>4.8</b>	<b>18.6</b>	<b>27.9</b>	<b>5.8</b>	<b>4.992</b>	<b>9.57</b>	<b>5.22</b>	<b>6.18</b>
RS1 - G1	43.526	6.9	22.8	39.4	5.8	4.83	20.97	5.49	7.278
RS1 - G2	56.693	4.6	14.6	25.8	7.9	6.182	8.29	5.2	5.373
RS1 - G3	52.641	4	20.1	28.4	5	8.106	13.31	5.18	5.868
RS1 - G4	55.849	3.9	14.5	25.2	4.3	6.458	7.56	5.12	7.392
RS1 - G5	48.421	4.5	16.6	31.6	6.2	4.605	10.64	5.08	4.248
RL2	96.799	5	14.8	22.2	4.6	10.224	9.71	5.53	24.739
RL2 - G1	98.131	2.6	6.6	11.3	3.7	8.424	4.95	5.65	17.471
RL2 - G2	94.967	4.8	11.9	24.9	3.9	10.276	9.78	5.42	21.924
RL2 - G3	96.466	4.8	13.2	20	3.9	6.437	8.43	5.48	34.896
RL2 - G4	98.131	5.3	16.8	22.9	4	9.666	11.89	5.57	32.784
RL2 - G5	96.133	5.2	10.5	25.5	5	9.239	11.71	5.61	20.473
RL3	50.375	4.6	16	22.5	5.8	8.308	10.59	5.23	9.258
RL3 - G1	38.771	5.3	11	26	5.8	3.331	5.15	5.21	3.735
RL3 - G2	62.477	6.2	22.2	29.9	6	6.209	11.2	5.4	15.808
RL3 - G3	43.247	5.6	15.5	26.2	6.4	4.389	9.5	5.34	6.235
RL3 - G4	57.338	5.9	25.7	29.6	4.8	8.046	13.72	5.44	11.263
RL3 - G5	44.905	5.9	16.8	34.6	5.6	7.642	7.46	5.27	4.876

---

Unit	ASC	Ca	K	Mg	Na	OS	P	pH	SO4
SV 1	63.43	3.6	8.6	31.9	4.5	6.791	4.72	5.26	9.715
SV 2	52.672	5	11.2	42.3	4.7	5.873	12.98	5.25	8.386
SV 3	53.513	5.1	8.2	40.6	4.7	6.217	14.66	5.39	7.228
SV 4	45.781	5.3	8.3	37.8	4.9	5.014	12.16	5.19	8.161
SV 5	79.736	3.3	8.3	22.2	3.8	7.766	5.29	5.19	17.115
PV 1	44.1	5.2	7.8	54.9	7	7.037	7.05	4.75	12.834

Unit	ASC	Ca	K	Mg	Na	OS	P	pH	SO4
PV 1	44.1	5.2	7.8	54.9	7	7.037	7.05	4.75	12.834
PV 2	65.616	3.4	11.2	26.7	4.5	9.125	9.8	4.61	16.919
PV 3	41.242	6.6	7.9	52.7	5.8	5.76	9.63	5.16	10.063
PV 4	37.376	6.4	7.8	48.5	5	6.242	5.86	5.18	16.591
PV 5	64.103	5.7	8.6	37.8	5	9.111	4.4	4.98	28.17



