



THE UNIVERSITY OF
WAIKATO
Te Whare Wānanga o Waikato

Research Commons

<http://researchcommons.waikato.ac.nz/>

Research Commons at the University of Waikato

Copyright Statement:

The digital copy of this thesis is protected by the Copyright Act 1994 (New Zealand).

The thesis may be consulted by you, provided you comply with the provisions of the Act and the following conditions of use:

- Any use you make of these documents or images must be for research or private study purposes only, and you may not make them available to any other person.
- Authors control the copyright of their thesis. You will recognise the author's right to be identified as the author of the thesis, and due acknowledgement will be made to the author where appropriate.
- You will obtain the author's permission before publishing any material from the thesis.

A preliminary evaluation of tectonic geomorphological signals within the Hamilton Basin

A thesis submitted in partial fulfilment

of the requirements for the degree

of

Master of Science in Earth Sciences

at

The University of Waikato

by

Francesca Spinardi



THE UNIVERSITY OF
WAIKATO
Te Whare Wānanga o Waikato

2017

ABSTRACT

Abstract

Over the past year several fault traces have been discovered within the Hamilton Basin, prompting a need for further investigation for tectonic evidence in the basin in order to reassess seismic hazards of the basin. Examination of the most recently discovered fault revealed the trace cross cuts the 20,000 ka Hinuera Formation, indicating that the faults within the Basin are active and could potentially experience another seismic event. However, more information is needed to determine the rate of occurrence and potential magnitude of an event. LiDAR and geomorphic data indicates there are potentially up to ten more traces within the Hamilton Basin, but they have yet to be confirmed through geomorphical ground-truth mapping. Both the known fault traces and the potential traces are dominantly NE oriented and appear to be influenced by the surrounding fault systems, such as the Waipa Fault. A large basement depression located in the far northern area of the Hamilton Basin as revealed by seismic line and gravitational data indicates that extensional movement may be related to the faults. To better understand the risk and hazard potential of a seismic event, extensive study and information about the basement terrane and surrounding faults, such as the Waipa Fault, needs to be gathered. It is possible that the fault traces within Hamilton are transtensional splays that have formed to accommodate movement and space between the major fault systems. My project will be examining the inferred fault traces within the Hamilton Basin, as indicated by the geomorphology, seismic line data, existing borehole data, and geological and geomorphical ground-truth mapping. For this the history of the surrounding fault lines, such as their total offset and rate of occurrence, will be investigated in order to understand the behavior of the faults within the Hamilton Basin and the potential hazards they can cause.

ACKNOWLEDGEMENTS

There are many individuals I would like to thank who have helped me so much on this project.

First to my supervisors Dr. Vicki Moon and Dr. Adrian Pittari. You both have been so wonderful, helpful, and patient with me on this project. From getting up at 4am for field work to having me randomly drop in your offices to run ideas by you even when you both have been very busy. I am very grateful and thankful to have such great supervisors who encourage me.

A big acknowledgement to Tom Robertson for coming with me on all field trips and helping me sample after I dislocated my arm. You really went above and beyond as a friend and colleague. I would not have been able to retrieve many of my results had I not had your help. Ben Campbell as well for helping in the field and always willing to chat so we could bounce ideas off of each other. I am glad we got to work on Kay Road together. I am thankful for having both you and Tom in the office. You guys helped me on both an intellectual level and on a stress management level.

A thank you to Caitlin and Jamie for encouraging me to take a moment to step away from my computer and so I could unwind both physically and mentally.

A special thank you to my friends Liz and Pip who have chatted with me about my research, helped proof read sections, assisted with field work, helped solve MS word issues when my computer glitched, and in general for being great friends who are supportive and loving.

The Waikato Regional Council for funding this project and providing me with the high resolution LiDAR data that was essential to this study. A thank you to Dudley for operating the boat for surveys from the wee minutes in the morning to late in the hot afternoons. Not to mention helping us hold the boat to the cliff faces so we could get samples. You are a good operator and I am glad you we had you on this project. Henry at Stubbs Road for giving access to your farm for multiple surveys. Shane and Michael out Newell Road. Thank you for allowing me access to your properties so I could map and sample the geology. Without these field sites a lot of questions would have remained unanswered.

Finally my family who have been so supportive of me on this project and encouraging me to advance my knowledge for better career outlooks; I love you guys and miss you every day. To my husband, Ben, who let me chat his ear off about project updates, findings, and supporting me with all the ups and downs that come when taking on graduate studies. I am thankful to have a fellow geologist as the love my life. May the geology puns never die.

TABLE OF CONTENTS

Abstract	i
Acknowledgements	iii
Table of Contents	v
List of Figures	ix
List of Tables.....	xvii
Chapter 1: Introduction.....	20
2.1 Background	20
2.2 Aims and Objectives	20
2.3 Study Area	20
2.4 Research Benefits	21
2.5 Thesis Structure.....	22
Chapter 2: Literature review	22
3.1 Chapter Framework	22
3.2 Understanding of the Geological History	23
3.3 A Geologic Introduction about the Hamilton Basin	25
3.3.1 Gravity Anomaly	26
3.3.2 Magnetic Anomaly.....	27
3.4 Basement Terranes of the Hamilton Basin	28
3.4.1 Murihiku Terrane.....	28
3.4.2 Dun Mountain-Maitai Terrane	30
3.4.3 Waipapa Composite Terrane.....	31
3.5 Quaternary Geological Units	32
3.5.1 Ongatiti Ignimbrite	32
3.5.2 Ahuroa Ignimbrite	33
3.5.3 Rocky Hill and Kidnappers Ignimbrite.....	33
3.5.4 Tephras.....	34
3.5.5 Walton Subgroup	34

3.5.6	Hinuera Formation.....	35
3.5.7	Taupo Pumice Alluvium	36
3.6	Faults	36
3.6.1	Fault anatomy.....	36
3.6.2	Primary Stresses	36
3.6.3	Formation and Propagation.....	37
3.6.4	Fault Cores and Damage Zone	38
3.6.5	Fault Zones and Conjugates.....	40
3.6.6	Normal Faults	41
3.6.7	Listric faults.....	41
3.6.8	Reverse Faults.....	42
3.6.9	Strike slip Faults	43
3.6.10	Relay Ramps.....	44
3.7	Tectonic Geomorphology	44
3.7.1	Drainage Patterns	45
3.7.2	Knickpoints	46
3.7.3	Aggradation and Degradation.....	46
3.7.4	River terraces.....	48
3.8	Regional Fault Lines	49
3.8.1	Waipa Fault.....	50
3.8.2	Taupiri Fault.....	50
3.8.3	Kerepehi Fault.....	51
3.8.4	Wairoa Fault	52
3.9	Concluding Remarks	52
	Chapter 3: Methodology	55
4.1	Introduction.....	55
4.2	Remote Sensing	55
4.3	Multibeam	56
4.3.1	Seismic DATA	56

4.4	Geophysical Data.....	57
4.4.1	Pre-existing Seismic Reflection Data	57
4.5	Field Survey Procedure.....	57
4.5.1	Geological Unit Mapping.....	58
4.6	Thin Sections	59
4.7	Scanning Electron Microscope	59
4.8	ArcGIS Mapping.....	59
4.9	Concluding Remarks.....	60
	Chapter 4: Results	63
5.1	Introduction	63
5.2	Remote Sensing.....	65
5.2.1	Multibeam Data.....	65
5.2.2	Gravity Survey Data	65
5.2.3	Older Seismic Data:	66
5.3	Stubbs Road.....	72
5.3.1	Geomorphology.....	72
5.3.2	Field Results.....	74
5.3.3	Multibeam and Seismic data	80
5.4	Hammond Park.....	84
5.4.1	Geomorphology.....	84
5.4.2	Field Results.....	85
5.4.3	Multibeam and Seismic Data	93
5.5	Day’s Park, Braithwaite Park, and Horotiu.....	97
5.5.1	Geomorphology.....	97
5.5.2	Field Results.....	98
5.5.3	Known Faults	108
5.5.4	Multibeam and Seismic Results.....	109
5.6	Areas of interest that were non0-conclusive.....	113
5.7	Concluding Remarks.....	114

Chapter 5: Discussion and conclusion	115
6.1 Introduction.....	115
6.2 Junction Magnetic Anomaly	115
6.3 Geomorphology of the Waikato River	116
6.4 Stubbs Road.....	117
6.5 Hammond Park.....	122
6.6 Day’s Park, Braithwaite Park, and Horotiu	126
6.7 The Hamilton Basin Fault Zones	131
6.8 Concluding Remarks and Future Research	136
References.....	141
Appendix I.....	149
Appendix II.....	155
Appendix III.....	165

LIST OF FIGURES

Figure 1.1. Map of the Hamilton Basin from Lowe (2010) showing the basins location within the central North Island. Fault lines within the region are indicated by the red lines and the Waikato River is indicated by the blue.....	21
Figure 2.1. Map displaying the location and distribution of the New Zealand Basement rock from Edbrooke (2005). All terranes are between Permian to Late Cretaceous in age, but figure also displays Early Miocene Northland and East Coast allochthons.	25
Figure 2.2. Gravity Anomaly Map of the Hamilton Basin from FrOG Tech (2001). The scale of the gravity values ranges from dark blue as low, indicating a depression in the basement filled with low density sediments, to pink as high indicating the upstanding basement.	27
Figure 2.3. . Map of the Murihiku Terrane from Edbrooke (2005) showing macro structure of the Kawhia Syncline. Note the NE arm of the Hakarimata anticline in the far northern area of the map and how it is not aligned with the rest of the syncline.....	30
Figure 2.4. Diagram of Fault systems and their associated stress regime orientation. Fault represents a response of rock to shear stress, type is determined by which primary stress is oriented vertically.	37
Figure 2.5. Cross section of fault trace to showing the designated deformation zones (Gudmundsson et al., 2010).....	39
Figure 2.6. Diagram of different propagation fracture structures that can form in both faults and microfractures. A) Tensile wind cracks. B) Shearing Horsetail splays. C) Shearing splay (branch) fractures. D) Antithetic shear fractures (Kim et al., 2006)	40
Figure 2.7. Diagram from Thatcher and Hill (1991) showing variations in conjugate faulting as primary stress continue to act on a failed system,.....	41
Figure 2.8. Cross section of listric fault with accompanying domino structures, synthetic faults, and antithetic faults (Burbank and Anderson, 2012). 42	
Figure 2.9. Diagram from Fossen (2010) of a strike slip fault with both relief and straining bends to show the dynamic structures that form in transpressional and transtensional areas.....	43
Figure 2.10. Diagram showing how offset fault lines create step over faults resulting in the formation of extensional systems or uplift (Fossen, 2010).....	44
Figure 2.11. Model of different types of geomorphic features that can form due	

to tectonic influences, from Burbank and Anderson (2012)	45
Figure 2.12. Variations of drainage patters from Howard (1968)	46
Figure 2.13. Experimental fluvial adjustments to systems experience uplift or subsidence from study conducted by Ochi (1985)	47
Figure 2.14. Diagram showing how river direction across a fault plane can result in different areas of aggradation and degradation. Diagram is based on similar one by Schumm et al. (2000).	48
Figure 2.15. Diagram from Fryirs and Brierley, 2013 showing variation in fluvial terraces.....	49
Figure 2.16. Diagram showing the Tauipi Fault’s location as it relates to the Waipa Fault and the Hakarimata Ranges, from Kirk (1991).	51
Figure 4.1. Colourized LiDAR map of the Hamilton basin from Tamahere to Horotiu. The brown represents areas of high elevation while the blue signifies low elevation. Hillshade effect with an elevation shading of 0.2m was used for this construction an all other LiDAR maps to follow. Major Ridges, Drainages, and River Bends are labelled for reference in this map. Field areas of focus are boxed in the blue, red, and green boxes. Note the similar trends that many of the ridge lines possess. For example, Ridge 1, 2, 8 and 9 intersect the river at River Bends, 3, 4, 7, 9, 10. The orientation of drainages and their catchments can also be observed in this map. Note that D1 has a catchment system with a dominate NW direction until it is cut off by a NNE tributary. A similar but less extensive form can also be observed for D5.	64
Figure 4.2. Gravity Anomaly Map of the Hamilton Basin from FrOG Tech (2001). The scale of the gravity values ranges from dark blue as low, indicating a depression in the basement filled with low density sediments, to pink as high indicating the upstanding basement. A) Indicated the lowest gravitational value forming a depression near Te Rapa. B) The secondary low gravitational value depression located near Gordonton. C) Third depression with a medium gravitational anomaly located near Melvill, Fitzroy, and Glenview areas.	66
Figure 4.3. Seismic Line 549-2 with the upper half showing the original seismic line with the marked discontinuities and divided fault zones, and the bottom half showing the discontinuities without the seismic line for better visual observiosn. Notice that the many of the structures contain curved failure planes and flower structures, particularly in zones 3, 4, and 6.	69
Figure 4.4. Seismic Line 549-16 with the upper half showing the original seismic line with the marked discontinuities and divided fault zones, and the bottom half showing the discontinuities with a clean background for	

better observation. Due to the resolution of the line the majority of discontinuities that are found are contained between Zones 2 and 4, but that is not to say more does not potentially exists in the norther section. 70

Figure 4.5. A) Geomorphic map of Stubbs Road. Major geomorphic features such as ridges, major drainage systems, avulsed/abandoned channels are shown. Important areas of interest in the field and from remote sensing are marked by station numbers. Locations with importance to field outcrops are marked by location numbers. Locations of additional investigations conducted through LiDAR cross sections and bore hole transections are presented on this map with specific results from these studies presented later on in this section. B) Geological Units map of Stubbs Road with all potential lithologies along the Waikato River presented in the Legend and mapped lithologies found in the field shown on the map..... 71

Figure 4.6. A) Cross section of terraces located at Station A. B) Cross section from east to west of the single terrace at Station C. C) Cross section across A1 channel from east to west. Note the three major terrace, to the west and a small fourth terrace near river level to the far east. 74

Figure 4.7. Map of showing the location of borehole transect taken at Station C along the lower terrace. Field locations are displayed by location numbers. The bearing between the two similar outcrops found at Location 1 to Location 2 across the river shown. Results from boreholes are presented in visual logs. 76

Figure 5.8. Photographs of samples R1S11(B) and R1S12 (A) taken from Locations 3 and 6. Left are resined samples while right are unresined samples. Thin section images of R1S11 (C) and R1S12 (D and E) taken at 4x magnification in plain polarized light..... 77

Figure 4.9. Photograph of Station E Location 8 of Ongatiti Ignimbrite cliff face. .. 78

Figure 4.10. A) Photograph of A1 channel looking from the south to the north. B) Photograph of the tallest terrace at Station D, where Locations 4 and 5 were. C) Photo of Hinuera Formation cross bedded coarse sands and gravels from Location 4..... 79

Figure 4.11. A) Photograph of fault outcrop at Location 1. The fault line is traced in red and cuts through the units toward the river. Samples taken from the outcrop are marked by numbers 1 and 2 on photograph. B) Close up of the lower section of the fault plane with ironpan percipitation, marked by red arrows, present within the fault line. Above offset beds can be observed. 1) Sample R1S8B_Lower consisting of ash section topped by glass shards, minerals, lithics and pumiceous material on top. 2) Sample R1S8D taken during second visit to the site. Consists of pumices and lithic pieces suspended in an ashy maxtrix..... 80

Figure 4.12. A) Sidescan Sonar and multibeam imaging taken during Wood’s (2006) investigation of the Waikato River’s geomorphology. Note the orientation of the depression seen in the multibeam image on the right. B) 3D multibeam image of the depression constructed by Wood (2006). Note the NE lineation along with a secondary step oriented N. C) Seismic survey results taken across along the bend and across the depression. Denser material is present to the south as seen by more reflected multiple material, whereas the north has fewer..... 82

Figure 4.13. A) Geomorphic map of Hammond Park. Major geomorphic features such as ridges, major drainage systems, avulsed/abandoned channels are shown. Important areas of interests in the field and from remote sensing examinations are marked by station numbers. Locations with importance to field outcrops are marked by location numbers. Locations of additional investigations conducted through LiDAR cross sections and bore hole transections are presented on this map with specific results from these studies presented later on in this section. Bearings between outcrops found at Location 10 to 11 and 12 to 13 are marked on this map. B) Geological Units map of Hammond Park with all potential lithologies along the Waikato River presented in the Legend and mapped lithologies found in the field shown on the map 83

Figure 4.14. Outcrops found at Location 11 with 10cm arrow for scale. Stratigraphic log of outcrops A and B are below in Fig. 4.15. A) R2S2.1 outcrop from the lower section of Location 11 where the terrace meets the ridge. Note the large ripped up silt clast where the scale arrow is located. Additional small ripped clast can be seen near the bottom left of outcrop. B) R2S2.2 second outcrop taken close to S2.1. Note the sharp contact and lens of iron stained pumice. C) R2S2.3 outcrop of thin layer of pumiceous coarse sands found up on the ridge line. D) R2S2.4 Ignimbrite outcrop at top of ridge. Event contact seen below the arrow marked by the change in colour. 87

Figure 4.15. Stratigraphic log of R2S2.1 and R2S2.2 as seen in photographs A (on Right) and B (on left) in Figure 4.14. Details regarding colour not addressed given photos are provided. Note the alternating layers of the R2S2.1 and how all material found at this site have a pumiceous component to their structure. 88

Figure 4.16. A) Photograph of outcrop at Location 12 with finger indicating the offset bed. Also note how far up this bed occurs, making it difficult to access. B) Ignimbrite outcrop at Location 10. C) Locally reworked ignimbrite outcrop found at Location 13. Field notebook for scale. D) Photo of borehole 4 of the white clay rich material in contact with Hamilton Ash above..... 90

Figure 4.17. Map of bore hole transect taken at Station K between Ridges 1 and 3. Bore holes 6 to 8 taken across a small hill with dip in middle that

had similar orientation to the minor Drainage. Cross section was taken from hole to hole along the ridge line on ArcGIS to get elevation due to issues with the GPS. Results of cross section and borehole data are given below in Figure 4.18. Location of ignimbrite outcrops found during boat survey are marked by Location 14 and 15. 91

Figure 4.18. Cross section of bore holes taken at Station K. Note the change of ignimbrite out crops at holes 4 and 5, with 5 having similar elevation to hole borehole 3. Dip in ridge line can be seen near boreholes 6-8 but results did not show difference in material. 92

Figure 4.19. A) Multibeam image taken by Wood (2006) with location of 3D images marked by numbers 1 and 2. 1) 3D multibeam image with a depression on the western side and a strong linear feature cutting across the bottom of the riverbed. This lineation is also stretches between Location 12 and 13. 2) 3D multibeam image with a depression on the northern side and a strong linear feature cutting around and across the riverbed near Bend 3. This lineation also stretches between Location 10 and 11 93

Figure 4.20. Seismic Survey data taken along Bends 3 and 4 at Hammond Park. Location of each specific survey image is marked by number 1-4 in the map below. Image 3 was taken along the transection of the scourhole seen in the 3D multibeam image in 4.19-2 and shows knickpoint with discontinuity. No transect was taken along the region between Location 12 and 13, but images 1 and 2, taken up and down river of that region, show a discontinuity. Image 2 shows a change in the density of the riverbed geology from less dense in south and more dense in the north. 95

Figure 4.21. A) Geomorphic map of region from Day’s Park to Horotiu. Major geomorphic features such as ridges, major drainage systems, avulsed/abandoned channels. Important areas of interests both in the field and from remote sensing examinations are marked by station number. Locations with importance to field outcrops are marked by location numbers. B) Geological Units map of Day’s Park to Horotiu with all potential lithologies along the Waikato River presented in the Legend and mapped lithologies found in the field shown on the map. 96

Figure 4.22. Photograph of Samples and outcrops found along Location 17 to 19. A) Outcrop found at base of hill at Location 17 near the river level. B) Photo of cleaned outcrop piece taken along foot path between location 17 and 19 that was taken for samples. C) Outcrop near Location 19 scraped along ridge line when it came close to the foot path. 100

Figure 4.23. Thin section images of F6S2 () and R1S12 (B) F2S3(C and D) taken at 4x magnification in plain polarized light are shown. 102

Figure 4.24. Photographs of outcrops found near and at Location 18 A) southernmost outcrop with erosion pipes in silt layer. B) Outcrop of R2S4 located on the southern section of Location 18. C) Outcrop near Day’s Park between Location 18 and Station M. Stratigraphic log taken from this outcrop..... 103

Figure 4.25. Stratigraphic log of outcrop near Location 18 displaying reworked volcanically derived material. Penecontemporaneous deformation seen with sag hole and ripped off pumice lapilli layer that has deposited into lower lying layer..... 104

Figure 4.26. A) Photography of decomposed tree in Hinuera Formation outcrop at Location 21 with 10cm arrow for scale. B) Location 20 where the geology drops sharply into the river as seen by the outcrop lines along the bank. 104

Figure 4.27. 28 Hinuera Formation outcrop at Location 23. A1) Photo of outcrop as a whole with 10cm arrow for scale and hand point to section where offset bed of silt was located. A2) Close up photos of the deep sag hole that cuts into the lower more organic unit with a large context photograph above and close up of the material in the hole below. A3) Close up of left side of outcrop showing how the organic layer structure. A4) Photograph of offset silt beds with 10cm tape measure for scale. 106

Figure 4.28. Outcrops at Station O. A1) Photograph of outcropped wall at Location 24 with close up of the outcrop shown in A2. B1) Photograph showing where the contact was followed to at Location 25, with where the unit disappears into the hills show in B2. C) Photograph of pumices suspended in clay matrix found under a tree near location 24. D) Outcrop with suspended pumice layer found while following contact between location 24 and 25..... 107

Figure 4.29. A) Submerged outcrop found at Horotiu at Location 26, Station Q. B) Photo of sample taken from the area once it has been dried and coated with a thin layer of resin on the outside to keep it from breaking during cutting. 108

Figure 4.30. A) Multibeam with sidescan sonar images displayed in A1 and the resulting 3D multibeam image shown in A2. B) Map showing where seismic surveys were conducted with results from survey marked as F2 and F1. Note F2 was taken near the 3D multibeam image, and shows a change in density of material with some failures. F1 shows a knickpoint with discontinuity contained within the depression. 110

Figure 4.31. Results of sidescan, multibeam, and seismic surveys. A1) Location of where the sidescan and multibeam test with the resulting 3D image presented in A2. A3) Seismic Survey results taken along the region showing a trough shape depression with two large discontinuities. 112

Figure 4.32. Results of sidescan, multibeam, and seismic surveys. B1) Location of the sidescan and multibeam test with the resulting 3D image presented in B2. B3) Seismic Survey results taken along the region showing a trough shape depression with two large discontinuities... 113

Figure 5.1. Geomorphic map of Stubbs Road showing faults lines, both inferred and exposed, marked as the small red lines in relation to the location of the proposed Te Tatua O Wairere Fault Zone. 119

Figure 5.2. Diagram showing how river direction across a fault plane can result in different areas of aggradation and degradation. Diagram is based on similar one by Schumm et al. (2000). 122

Figure 5.3. Geomorphic map of Hammond Park showing faults lines, both inferred and exposed, marked as the small red lines in relation to the location of the proposed Te Tatua O Wairere Fault Zone. 124

Figure 5.4. Geomorphic map of the area from Day’s Park to Horotiu showing faults lines, both inferred and exposed, marked as the small red lines in relation to the location of the proposed Kukutaruhe Fault Zone. Secondary Fault zones are indicated by dashed blue lines, and proposed splays linking the secondary fault zones to the main fault zone are indicated by the dotted green lines..... 127

Figure 5.5. Map showing the location of the proposed Kukutaruhe and the Te Tatua o Wairere Fault zones based on the geomorphic and field evidence from this study. Secondary fault zone systems are indicated by the blue dashed lines and proposed connecting splays by the green dotted lines. Fault lines either found or inferred during this study are shown by the small red lines along the Waikato River. 132

Figure 5.6. Map of proposed tectonic hypothesis for how and why the fault zones in Hamilton are forming. The influential faults, the Waipa and the Maungaroa Fault indicated by the light blue, are offset. The Taupiri Fault, also indicated by the light blue line, is the breached failure linking the two faults. Note that though the active Wairoa fault is not highlight blue, it has a similar orientation to the Maungaroa Fault, indicating that it too could be contributing to the formation of fault zones in Hamilton..... 135

LIST OF TABLES

Table 4.1. Table of measured angles of the river bend. These angles are approximate based on lines draw on down the main river path on GIS maps and then measured with a protractor	72
---	----

CHAPTER 1

INTRODUCTION

1.1 Background

In the New Zealand active faults database the Hamilton Basin stands out as one of the few areas of New Zealand with no mapped active faults. As a result, residents of Hamilton City and surrounding communities are assessed as living in an area of comparatively low seismic hazard. However, in 2015 a fault trace was exposed during excavation at the Rototuna subdivision; since that discovery further fault traces have been recognised in earthworks at Horsham Downs (Campbell, 2017), and indications of others revealed by shallow seismic surveying of the Waikato River bed (Moon and de Lange, 2017). These observations suggest that the Hamilton Basin may contain a network of faults offsetting the Pleistocene sedimentary deposits that infill the basin, and thus question the interpretation of a low seismic hazard. With the advent of high resolution LiDAR imagery Hamilton Basin's geomorphology could not be analysed for potential faults structures. The course of the Waikato River which runs from south to north through the basin, an orientation approximately normal to the measured faults traces so far identified, provides a perfect linear indicator for examining tectonic influences on the river's profile.

1.2 Aims and Objectives

The purpose of this study is to develop a model for faulting within the Hamilton Basin using geomorphic signatures of displacement as the key line of evidence. Objectives defined to achieve this aim are:

- a) to review existing geological, geomorphic, and geophysical data that may contain evidence of faulting structures;
- b) to use LiDAR to identify potential structures associated with tectonic influences, particularly along the course of the Waikato River.
- c) to use standard geological mapping techniques to ground truth identified targets;
- d) to interpret the results in terms of a model for the distribution of faults in the basin.

1.3 Study Area

The area of study is located in the Hamilton Basin. The basin is located in the central North Island of New Zealand just south of Auckland and between Raglan and Morrinsville (Fig. 1.1). Ranges on all sides confine the basin and a large river, the Waikato River, enters the

basin from the south at Maungatautari Gorge and leaves the basin through the Taupiri Gorge. The study area will give specific attention to the Waikato River as it winds its way from the Narrows Bridge, through Tamahere to the Horoitui Bridge.

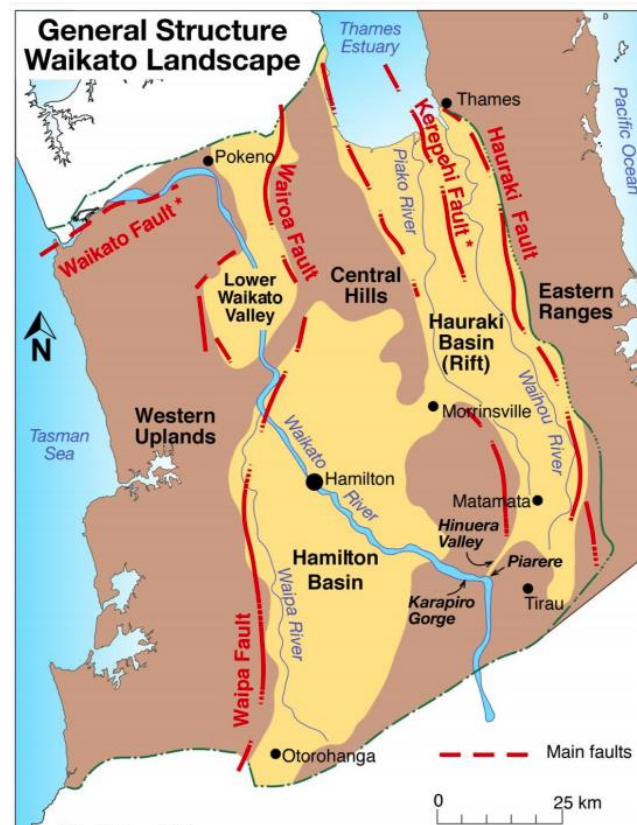

Figure 1.1. Map of the Hamilton Basin from Lowe (2010) showing the basins location within the central North Island. Fault lines within the region are indicated by the red lines and the Waikato River is indicated by the blue.

1.4 Research Benefits

Information gathered from this study will act as a form of reconnaissance to understanding the structural geology of the Hamilton Basin. This understanding will aid with:

- a) guiding planning for community resilience;
- b) as an aid in geotechnical site works;
- c) in planning future research to more fully define locations and activity on the faults.

1.5 Thesis Structure

My thesis is broken into 5 Chapters with the aims, study area and thesis structure presented in this chapter. In order to understand the background issue regarding fault structures in the Hamilton Basin and their potential seismic hazards a review of the

literature directly associated with geological history of the Hamilton Basin was conducted. Information regarding not only the geologic history of the Hamilton basin, but information regarding faults and tectonic geomorphology was also covered. Chapter 2 consists of a literature review regarding foundational information about faults, tectonic geomorphology, and the geological history of the Hamilton Basin that is known prior to this study. Given that much of this information was gathered through the reading of foundational textbooks and papers that presented findings from both laboratory and natural settings many of the tectonic geomorphology reference used will be from these foundational publications. The methods used in this study will be presented in Chapter 3 including remote sensing methods, discussion of pre-existing data sources such as drill logs, older seismic images, and previous geomorphic studies, and laboratory methods. Methods regarding the proceeds conducted in the field and how samples were examined and processed are presented in Sections 3.5 to 3.8. The results of this study are be presented in Chapter 4. For organization purposes the results regarding the geomorphology, field mapping, seismic scanning, and multibeam surveying are broken into three subsections relating to specific locations along the Waikato River. The focus locations will be Stubbs Road, Hammond Park, and Day's Park to Horotiu. In Chapter 5 a discussion of the results and initial interpretation of the fault structures within the Hamilton Basin is presented. Suggestion are made for the next stages in this research.

LITERATURE REVIEW

2.1 Chapter Framework

This chapter is a review of established knowledge is presentation. Section 2.2 will discuss an overview of New Zealand Geological history in order to establish a greater view context for the tectonic evolution of the Hamilton Basin. This overview regarding the tectonic evolution of New Zealand will then be followed by discussion of previous geophysical studies conducted in the Hamilton area and what these studies have found regarding the basement structures contained in the Hamilton Basin. Detailed information regarding the basement terranes present in and near the Hamilton Basin will be presented in Section 2.4 followed by information regarding Quaternary lithologies that are present in the basin. Section 2.6 will be discussing basic information regarding faults types, their formation, propagation, anatomy, and structures. Following Section 2.6, presentation regarding information of tectonic geomorphological signatures will be discussed. Cited works for Section 2.7 will be based predominantly on the fundamental literature regarding tectonic geomorphology, active tectonics in alluvial systems, and fluvially geomorphology. In Section 2.8 information regarding the regional fault lines present near the Hamilton Basin will be discussed.

2.2 Understanding of the Geological History

The basement terrane of New Zealand is composed of ultramafic ophiolites, serpentine deposits, and multiple sedimentary complexes that were either accreted or sutured onto the east coast of Gondwanaland between the Mid Cambrian to Late Cretaceous during the Rangitata Orogeny (Coombs et al., 1976; Spörli 1978; Ballance and Campbell, 1993). The amalgamated sediments experienced rapid burial causing them to undergo low grade metamorphism, and later were exhumed (Kamp et al., 2000; Jiao et al, 2014). Each terrane contains a series of stratigraphic units that are bound on either side by faults, a formation referred to as a tectonostratigraphic unit (Fig. 2.1). These binding faults formed between the Late Paleozoic to Early Cretaceous and possessed either a subduction, strike-slip, or dextral transpressional motion (Ballance, 1993; King, 2000; Mortimer, 2004). Though these faults are associated primarily with active compressional tectonics that occurred along the

western Gondwanaland margin, there is evidence that they were reactivated during Eocene rifting and subduction from the Kaikoura Orogeny (Laird, 1993; O'Brien and Rodgers, 1973). Between 112 to 82 Ma extension along the east coast of Gondwanaland began to occur, causing substantial mantle upwelling, crustal thinning, and in some regions, subsidence along the coastal margins (Kamp et al., 2000; Furlong and Kamp, 2009; Laird and Bradshaw, 2004; Tulloch et al., 2009). Extensional movement occurred in a NNE direction, resulting in the formation of a series of half grabens that were infilled (Laird, 1993). Normal faults with a WNW orientation formed with NE to NNE secondary faults acting as transform faults. By the Late Cretaceous the transform faults were reactivated as normal and oblique-slip faults (Laird, 1993; Tulloch et al., 2009). Many of these fault traces are still present in the Waikato region such as the Waipa and the Marokopa faults. Detachment of Zealandia from Gondwanaland began around 80 Ma resulting in the immersion and formation of Zealandia as a passive margin. Zealandia experienced almost complete immersion resulting in large transgressive sequences, such as the Te Kuiti Group found in the North Island, to be deposited until the inception of the Pacific Plate boundary in the Oligocene (Ballance, 1993). Subduction began along New Zealand's eastern coast and progressed southward, rotating around the East Cape to its current position along the Hikurangi Trough. Upon the initiation of subduction, the basement and younger sedimentary rocks of New Zealand became uplifted (Ballance, 1993; King, 2000). The onset of a compressional regime created areas of back arc spreading within the Taupo and Hauraki regions and back thrusting near Taranaki (King, 2000; Stagpoole and Nicol, 2008). There is little information regarding movement along the tectonostratigraphic fault lines during this time.

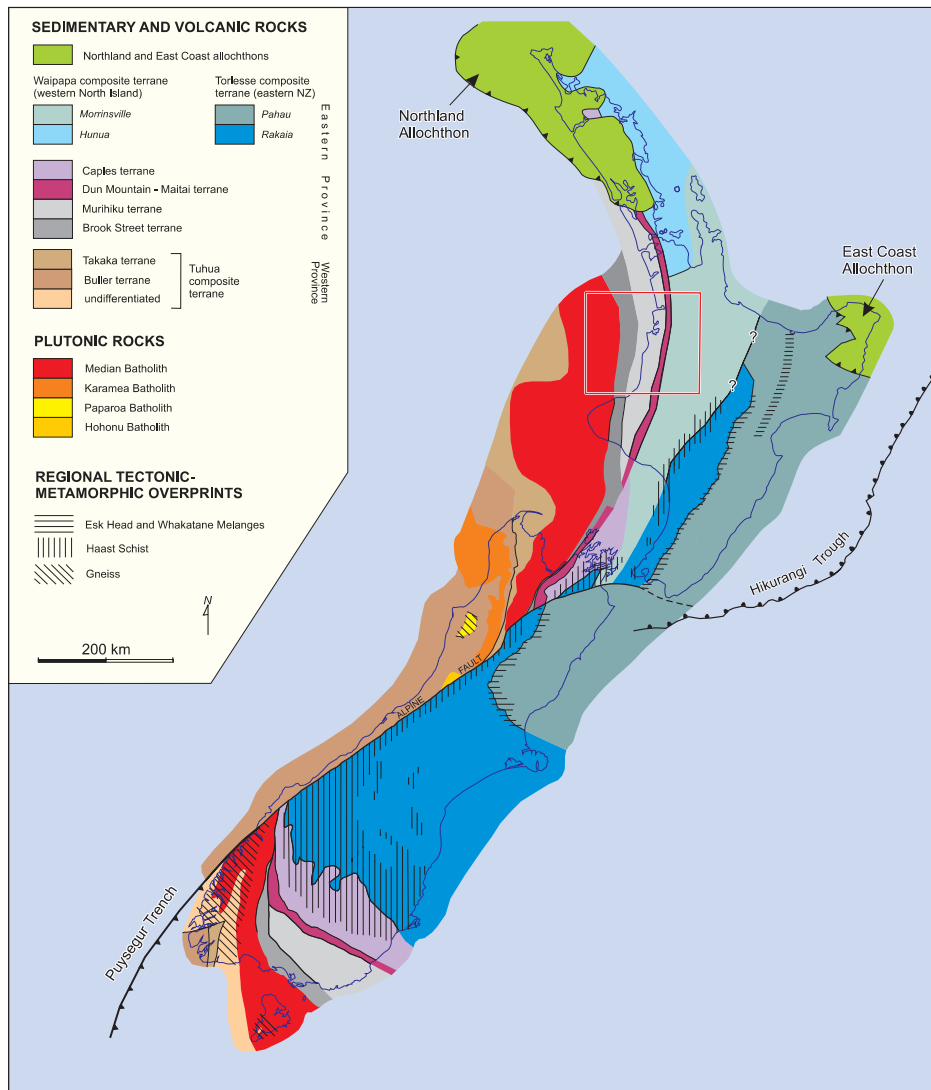

Figure 2.1. Map displaying the location and distribution of the New Zealand Basement rock from Edbrooke (2005). All terranes are between Permian to Late Cretaceous in age, but figure also displays Early Miocene Northland and East Coast allochthons.

2.3 A Geologic Introduction about the Hamilton Basin

The Hamilton Basin is a depression confined by the eastern arm of the Kawhia Syncline to the west, the Hakarimata-Taupiri Ranges to the north, and the Pakaroa Ranges and Maungakawa Hills to the east. Basement rock is present around the edges of the Basin and consists of the Murihiku Terrane, the Dun Mountain-Maitai Terrane, and the Waipapa Composite Terrane. Though basement rock and Te Kuiti Group sediments are present in the Hamilton Basin they are mostly buried by up to hundreds of metres of fluviially and alluvially reworked volcanoclastic materials referred to as the Walton Subgroup, and Holocene alluvial fan sediments referred to as the Hinuera Formation (Selby & Lowe, 1992; Edbrooke, 2005). The basin was first formed 5.0 Ma during the Kaikoura Orogeny when normal faulting produced a series of horst and graben features across the Waikato region

(Selby 1967). After the basin was filled with Mangakino sourced ignimbrites and various tephra from the Coremendal, and Taupo spreading centre. During the Early Pleistocene these volcanic deposits remained exposed to the elements and become weathered and then later alluvially and fluvially reworked forming the Walton Subgroup (Selby and Lowe 1992). Overlying the Walton Subgroup is a low-angle alluvial fan deposit of reworked volcanic sediments known as the Hinuera Formation. The Hinuera Formation covers almost all of the Hamilton Basin (McCraw 2011; Selby and Lowe 1992), apart from relatively small exposures of the earlier Pliocene Walton Subgroup in hills.

2.3.1 Gravity Anomaly

Gravitational surveying is a common tool used in geophysics to examine subsurface structures (Lowrie, 2007). It was gravitational mapping that led geophysicists to the discovery of isostasy. In the case of basins, gravitational surveying is important because it allows scientists to determine the location and extent of an underground structure. Scientists could describe these features by comparing the structure's density in relation to the density of the surrounding material (Lowrie, 2007).

Gravitational surveying (FrOG Tech, 2011) coupled with aeromagnetic data from Meyers in 2009 were available on the NZ Petroleum and Minerals website and used as subliminal images in conjunction with ArcGIS mapping conducted in this study. The goal of the survey was to have a better understanding of the basement structures within the Waikato in order to evaluate potential natural resources (FrOG Tech, 2011). The evaluated areas have a misproportioned polygonal shape with a larger E-W map area in the north and a smaller area in the south. The survey area extends from Papakura to Te Miro. In the northern portion the map extends from the Naikē to the base of the Kaimia Ranges just beyond the Huraki Rift in the east. In the southern region it extends from the base of the Kaimais to slightly west of Te Miro (Fig. 2.2). Though the Hamilton Basin is not a region of focus in the report, several of the survey maps and their results include the basin in order to discuss the full tectonic history and structure of the region (Fig. 2.2).

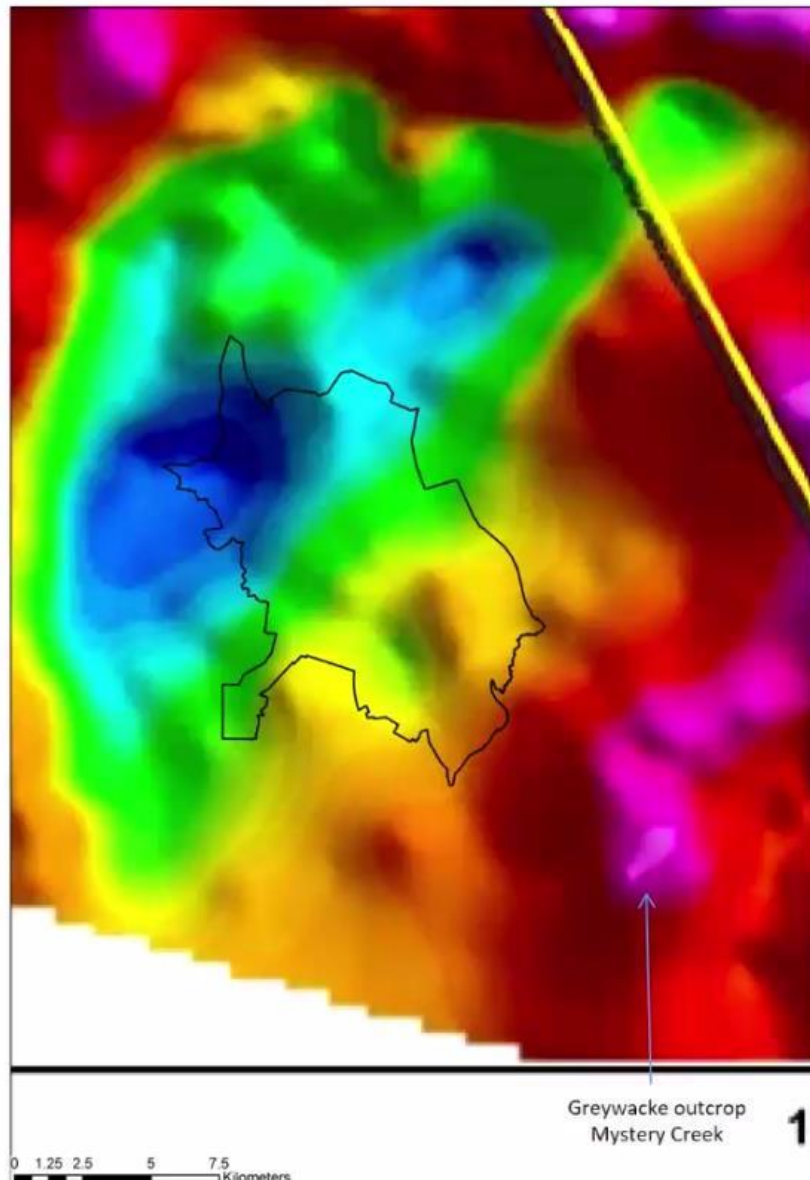

Figure 2.2. Gravity Anomaly Map of the Hamilton Basin from FrOG Tech (2001). The scale of the gravity values ranges from dark blue as low, indicating a depression in the basement filled with low density sediments, to pink as high indicating the upstanding basement.

2.3.2 Magnetic Anomaly

The Junction Magnetic Anomaly (JMA) is a large linear tectonic feature that is related to the Dun Mountain-Maitai Terrane. Discovered by Gerard & Lawrie in 1955 during the first airborne magnetic survey, the JMA stands out as a well-defined positive magnetic feature (Hunt, 1978). The anomaly is slightly bow shaped, oriented NNW to SSW, and extends from the top of the North Island just east of Cape Reinga down through eastern Taranaki and offshore through the Tasman Sea where it is offset by the Alpine Fault (Hunt, 1978; Eccles et al., 2005). It is associated with various types of deep-ocean and ultramafic rocks, such as the Dun Mountain Ophiolite Belt (DMOB) dating back to the Early Permian-Mid Triassic

(Hunt, 1978; Ballance & Campbell, 1993; Mortimer, 2004; Eccles et al., 2005). Though the geologic formations and structures that make up the JMA are not always present on the surface the anomaly marks the location of a major tectonic feature called Waipa Fault (Kear 1960; Ballance and Campbell, 1993). In relation to the field area the Waipa Fault stretches along the western border of the Hamilton Basin and is undisturbed by the rotation of the Hakarimata Block (Edbrooke et al., 1994). Movement along the Waipa fault is believed to have begun during the Late Cretaceous and ended prior to the Deposition of the Te Kuiti group in Tertiary. However, there is still debate among the scientific community regarding this timing.

It is interesting to see that the JMA is undisturbed by the Hakarimata Block. Hunt (1978) discusses this abnormality and aquatints it to a gravity slide. Kirk (1991) proposed that instead the fault experience dextral slip causing the Hakarimata block to be rotated and a secondary fault, named the Taupiri Fault, to form. Others have also pointed out that the rotation of the Hakarimata and Taupiri Ranges is evidence that right lateral motion did occur along the Waipa fault and it is possible that basement faults act as a means to accommodate such motion (King, 2000).

2.4 Basement Terranes of the Hamilton Basin

A Basement terrane's age and compositional sedimentary groups can vary depending on which island of New Zealand the terrane is located in. In this review the terranes of the North Island, particularly those located near and around the Waikato region, will be the focal point of discussion. The basement terranes that are particularly important in this region are the Murihiku, the Dun Mountain-Maitai, and the Waipapa Composite Terranes.

2.4.1 Murihiku Terrane

The Murihiku Terrane is the oldest of the three basement terranes. It is composed of Late Triassic to Early Cretaceous low grade metamorphosed sediments (Kear, 1971; Kamp et al., 2000). The terrane lies along the west coast of the North Island. Toward the northern segment the terrane is oriented NNW and to the southern the terrane is oriented SSW. The metamorphosed sediments were derived from either a backarc or forearc setting that was accreted and folded into a large, dominantly open, synclinal fold belt, called the Kawhia syncline (Spörli 1978; Ballance and Campbell, 1993; Black et al., 1993; Fig. 2.3). Evidence that folding occurred prior to the placement of Eocene sediments is seen in the erosional surfaces of the fold belt, its unconformable contact to the younger transgressive sediments, and its low grade metamorphic phases (Spörli 1978; Kamp et al., 2000). The Murihiku Terrane is confined by the Taranaki Fault in the west and the Waipa Fault in the

east (Ballance and Campbell, 1993; Briggs et al., 2004; Stagpoole and Nicol, 2008). However, a small anticlinal arm of the terrane has been rotated to a NE orientation forming the Hakarimata and Taupiri ranges north of Hamilton (Kear and Schofield, 1968; Kirk, 1991). The Murihiku Terrane consists of five stratigraphic groups named Newcastle, Rengarenga, Kirikiri, Apotu, and Huriwai (Briggs et al., 2004). The Newcastle group consists of Early Triassic to early Jurassic shallow marine sediments, such as sandstone, siltstone, shell beds, and volcanogenic conglomerate, interlayered with tuffs (Kear and Schofield, 1964; Edbrooke, 2005). The Rengarenga Group consists of shallow marine and terrestrial sediments that are Early to Middle Jurassic in age (Fleming and Kear, 1960; Edbrooke, 2005). Above is the Kirikiri Group composed of siltstone, conglomerates, tuffs, and minor sandstone bed that are Middle Jurassic in age (Fleming and Kear, 1960; Kear and Mortimer, 2003). Overlying the Kirikiri Group is the Late Jurassic Apotu Group sediments. The Apotu Group is composed of bathyal fans to inner shelf conglomerates, sand, and siltstones with volcanoclastic material (Kear and Mortimer, 2003; Edbrooke, 2005). Huriwai Group is Late Jurassic nearshore and fluvial sediments with large concentrations of volcanoclastic material (Purser, 1961; Ballance, 1988).

possesses key features, such as sheared serpentine deposits, that are important to understanding the history of fault movement in the North Island of New Zealand. Though the DMOB is not always clearly present on the surface its location is traced by the Junction Magnetic Anomaly (JMA) (Hunt, 1978). The correlation between the JMA and the ultramafic deposits of the DMOB was first proposed by Hatherton in 1967 and since then many scientists have confirmed this relationship (Coombs et al., 1976; Davy, 1993; Mortimer, 2004; Eccles et al., 2005).

The Dun Mountain-Maitai terrane is slightly bow shaped, similar to the Murihiku Terrane, and extends deep into the lithosphere. Its orientation follows the Waipa Fault, suggesting that the terrane is a suture boundary (Ballance and Campbell, 1993). It is steeply dipping to overturned in regions with some areas possessing extensive imbricated systems and shear zones (Eccles et al., 2005). During the formation of the Kawhia Syncline the terrane was steeply tilted to completely overturned in some regions and is postulated by Eccles et al. (2005) to have been semi-folded along the outside of the Murihiku Terrane. Most of the ophiolite deposits in the North Island are present in the Northland region and are deposited as inward dipping thin sheets less than a 1 km wide (Cassidy and Locke, 1987). In the South Waikato region, near the town of Piopio, a narrow lensoidal deposit of serpentinite is present (O'Brien and Rodgers, 1973). The deposit is highly sheared and shows evidence of strike-slip motion (O'Brien and Rodgers, 1973; Eccles et al., 2005). Serpentine pebbles have been found in the younger Eocene to Oligocene Te Kuiti Group giving evidence that the deposition of the Te Kuiti group was occurring while the serpentine formed. Offset and tilting of the Te Kuiti Group sediments by the serpentine also give evidence that both were formed around the same time (O'Brien and Rodgers, 1973). To the west of the Waipa Fault boundary, the Murihiku Terrane is sheared and pinched between the serpentine and limestone of the Te Kuiti Group, indicating that reactivation of the Waipa fault occurred between the Late Eocene to Oligocene (O'Brien and Rodgers, 1973). Serpentine is associated with deep mantle deposits and is widespread along the ocean floor (Cannat et al., 2010). Due to their mineralogical composition serpentinites can carry large quantities of water even when subducted and heated at great depths, resulting in their ability to act as a form of "lubricant" between faults (Deschamps et al., 2013).

2.4.3 Waipapa Composite Terrane

East of the Waipa Fault is the Waipapa Composite Terrane. It is a Jurassic to early Cretaceous low grade metamorphosed sedimentary unit. Due to its highly weathered nature and limited exposure discrepancies regarding bedding identification and structural

features have created ongoing debates among the geologic community (Kear, 1971; Black, 1994; Adams et al., 1998; Kear and Mortimer, 2003; Edbrooke, 2005). There have been debates regarding the Waipapa Terrane and its sedimentary groups, where some scientists consider the Apotu and Huriwai Groups of the Murihiku Terrane and the Manaia Hill Group of the Waipapa Terrane to be part of a Late Jurassic to Early Cretaceous overlap sequence called the Waipa Supergroup (Kear and Mortimer, 2003; Campbell et al., 2003). However, this proposal was not officially accepted by the geological community of New Zealand and has since been abandoned (Briggs et al, 2004; Edbrooke, 2005). However, it is agreed that the Waipapa Composite Terrane formed from an accretionary wedge due to the presence of interlayered and mixed ocean floor deposits together with clastic sedimentary rocks (Spörli et al., 1989; Briggs et al., 2004). It is understood that Kear and Mortimer's (2003) proposal to classify the basement sediments as the Waipa Supergroup has not been accepted. Therefore, the information presented in this review will be based on the original descriptions of the Waipapa Composite Terrane.

The Waipapa Terrane is composed of two facies named the Hunua and Morrinsville (Kear, 1971; Spörli et al., 1989). Within the Waikato region, however, only the Morrinsville Facies is present near the Hamilton Basin, so detailed discussion of the Hunua Facies will not be conducted for this review (Kear and Schofield, 1978; Edbrooke, 2005). The Morrinsville Facies is composed of a single sedimentary group called the Manaia Hill Group which is composed of Late Jurassic to Early Cretaceous, coarse low-grade metamorphosed, volcanoclastic sandstone with argillite chips, minor conglomerates, and siltstone beds (Kear, 1971; Black, 1994; Edbrooke, 2005). It is less metamorphosed and imbricated than the Hunua Facies but has still undergone extensive faulting (Kear, 1971; Kamp et al., 2000). Boulders within the conglomerate beds contain Late Triassic to Early Jurassic aged fossils probably sourced from the Murihiku Terrane during an erosional period (Kear, 1971; Black, 1994).

2.5 Quaternary Geological Units

2.5.1 *Ongatiti Ignimbrite*

Most of the ignimbrite formations that are known in the Hamilton Basin, originated from the Mangakino Caldera. The Oldest of these ignimbrites is the Ngaroma, but information regarding this ignimbrite indicated that it is not easily found in the Waikato especially not near Hamilton (Brink, 2012). A major ignimbrite that is found in the Hamilton Basin though is the Ongatiti. The Ongatiti was deposited 1.21 ± 0.04 Ma was the most voluminous and wide spread of the Mangakino ignimbrites with more than 300 km^3 of material deposited

throughout the North Island including the Waikato (Briggs, et al., 1993; Houghton, 1995). The ignimbrite is welded in locations near the Mangakino Caldera, while distally it is partially to non welded. The Ongatiti consists of two units that are separated by a sharp wavy contact (Wilson 1986a; Briggs et al., 1993). The lower unit is densely welded, crystal rich, and poor in pumice and lithics (Wilson 1986a, Cartwright, 2003). The upper unit is massive and variably welded with some depositional areas being densely welded and others partially or non welded (Wilson 1986a; Briggs et al., 1993). It also enriched with crystals, but unlike the lower unit it is high in lithics, and pumice (Wilson 1986a, Briggs et al., 1993, Cartwright, 2003; Brink, 2012). The upper unit is the more extensive of the two and can be found in and near the Hamilton Basin (Briggs et al., 1993; Cartwright, 2003). What makes this ignimbrite stand out among the others is its high abundance of lapilli to bomb sized pumices and glomeroporphyritic crystal clots (Wilson 1986a, Briggs et al., 1993; Cartwright, 2003)

2.5.2 Ahuroa Ignimbrite

The Ahuroa is 1.18 ± 0.04 Ma and the result of a highly energetic rapid eruption from the Mangakino Caldera that increased with time (Houghton et al., 1995; Brink, 2012). It is a veneer debris deposit with a distinct non welded lower black to grey colour base (Brink, 2012). Though its bottom is dark and poorly welded the Ahuroa gradually becomes densely welded towards its top while grading to a more yellow colour in its middle and then white at its top (Brink, 2012). The Ahuroa is enriched with feldspar crystals and pumices that vary between rhyolitic and dacitic at the bottom and lenticular towards the top (Wilson 1986a; Briggs et al., 1993; Brink, 2012).

2.5.3 Rocky Hill and Kidnappers Ignimbrite

Though the Rocky Hill and Kidnappers ignimbrite are separate units, both are close in age and physical characteristic, such as being sourced from the same volcanic centre, consisting of partially welded sections, and being rich in crystals and pumice. Thus, such similarities make it difficult to tell them apart at times (Wilson, 1986a; Moyle, 1989; Cartwright, 2003). The Rocky Hill Ignimbrite is a 1.0 ± 0.05 Ma partially welded ignimbrite that is crystal and pumice rich with rhyolitic, andesitic, and densely welded Ongantiti ignimbrite lithic fragments (Houghton et al., 1995; Wilson, 1986a; Moyle, 1989). The Kidnappers Ignimbrite is the younger of the two formations dating to 0.9 ± 1.02 Ma. It is a partially to densely welded ignimbrite consisting of Phreatoplinian ash, and rich in crystals and hornblende (Briggs et al., 1993; Cartwright, 2003)

2.5.4 Tephtras

The Kauroa Ash is a 2.24 Ma unit composed of multiple tephra sequences and paleosols (Lowe *et al.*, 2001). The presence of paleosols is an indication that long periods of time separate some of these tephra deposits allowing them to be severely weathered causing the unit to have a rich clay content. Sources contributing to the Kauroa Ash have been linked to possibly the Coromandel Volcanic Zone or the Mangakino Caldera (Lowe *et al.*, 2001).

The Hamilton Ashes are a 3-5m thick deposits consisting of multiple tephtras deposited between 350 Ka to 18 Ka (Lowe *et al.*, 2001). The ashes lie unconformably over lay the Kauroa Ash with the oldest tephra, the Rantitawa Tephra, marking the transition due to its distinct nature (Lowe *et al.*, 2001). The Rangitawa Tephra is 350 Ka and unlike the other tephtras in the Hamilton Ashes the Rangitawa has a distinct a micaceous greyish-brown layer marked with a lower coarse, yellow, sandy boundary layer at the bottom (Selby & Lowe, 1992; Lowe *et al.*, 2001). Following the Rangitawa Tephra the rest of the Hamilton Ashes consists of a brown and reddish-yellow clay layers, the left overs of the strongly weathered tephtras that followed the Rangitawa (McCraw, 2011). Though the specific ages of these individual tephtras are unknown distinct characteristics within their chemistry show that they were laid at different times with up to a thousand years between events.

2.5.5 Walton Subgroup

Little is known about the WSG units but what has been discovered is that the Walton Subgroup (WSG) is a sequence of formations that consists predominantly of alluvial and fluvial reworked rhyolitic materials, such as non welded ignimbrites and tephtras (Selby & Lowe, 1992; Edbrooke, 2005, McCraw, 2011). It is quaternary in age and deposited in a continental environment (Kear and Schofield, 1978; Selby & Lowe, 1992; McCraw, 2011). The subgroup can be broken into two formations called the Puketoka and the Karapiro Formation. The Puketoka is the oldest and consists of clays, pumiceous sands and gravels, breccias, and distal portions of rhyolitic ignimbrite sheets (Kear and Schofield, 1978). The upper portion of the Puketoka contains greywacke detritus call the Waerenga Gravels indicating that some of the material of the Puketoka was deposited through an alluvial system that have transported eroded basement material (Kear and Schofield, 1978; Selby & Lowe, 1992). The Puketoka Formation can range from white to grey and contains well bedded and sorted sands and conglomerates of pumice (Kear and Schofield, 1978). The youngest formation of the Walton Subgroup is the Karapiro consisting fluvial reworked rhyolitic volcanic material, possibly ignimbrite. Due to this reworking the volcanically

derived material found within the Karapiro was subjected to severe weathering causing much of it to become clay (Kear and Schofield, 1978; Selby & Lowe, 1992). Both the Puketoka and mostly the Karapiro contain current bedded structures reflecting the braided and meandering nature of the streams that transported and initially deposited the material (Kear and Schofield, 1978; Selby & Lowe, 1992; Edbrooke, 2005; McCraw, 2011). It has been suggested that the WGS after deposition created a topography of low relief and was later carved by streams leaving behind only portions of the deposit as high hills in the Hamilton Basin (Kamp & Lowe, 1981; Selby & Lowe, 1992; Lowe et al., 2001; Edbrooke, 2005; McCraw, 2011).

2.5.6 *Hinuera Formation*

The Hinuera Formation is the remnants of a 22 Ka mass alluvium volcanoclastic low angle fan that drained from Taupo through the Maungatutiri Gorge, and then into the Hamilton Basin (Hume *et al.*, 1975; Selby & Lowe, 1992; Melville, 2002;; Lowe, 2010; McCraw, 2011). Within the Haurai Lowlands the Hinuera Formation can also be found, indicating that during its time the Waikato River once drained to Thames but was cause to change direction, possibly from damming of the river during deposition, causing it to reroute to Hamilton (Selby & Lowe, 1992; Melville, 2002; McCraw, 2011). The Hinuera Formation is composed of rounded unconsolidated sediments consisting of quartz, feldspar, pumices, heavy mineral and rock fragment (Hume *et al.*, 1975; Selby & Lowe, 1992). The size of the grains composing the Hinuera Formation vary greatly from gravels to clays and form various current bedded structures indicating that the Hinuera Formation was deposited rapidly (Hume *et al.*, 1975; Selby & Lowe, 1992; Melville, 2002). Sedimentary structures observed within the Hinuera Formation together with geomorphological influences with in the Hamilton Basin indicates that the ancestral Waikato River used to be a braided river system flowing along a low angle fan and depositing/transporting material as it made its way to Port Waikato (Hume *et al.*, 1975; Selby & Lowe, 1992; Melville, 2002; Edbrooke, 2005; McCraw, 2011). The Hinuera Formation extensively covers the Hamilton Basin and can be found up to 90m thick in some location (Selby & Lowe, 1992; Edbrooke, 2005; McCraw, 2011). Since the Hinuera Formation contains volcanoclastic current bedded material similar to section of the Walton Subgroup, it can be difficult at times to tell them apart. The roundness of the sediments found in the Hinuera Formation together with the presence of the heavy minerals, quartz, and rock fragments help to distinguish the Hinuera Formation from section of the Walton Subgroup, particularly the Puketoka Formation (Hume *et al.*, 1975; ; Kear and Schofield, 1978; Selby & Lowe, 1992; Edbrooke, 2005)

2.5.7 Taupo Pumice Alluvium

The Taupo Pumice Alluvium is an 1850 year old sedimentary deposit consisting of predominantly pumiceous gravels and sand from the Taupo Eruption. The Taupo Pumice Alluvium is often found as one of the main sedimentary deposits along the terraces of the Waikato River, making some suspect that much of it has been eroded away (Hume *et al.*, 1975; Selby & Lowe, 1992; Melville 2002).

2.6 Faults

2.6.1 Fault anatomy

Faults are special lithospheric features that serve as evidence for seismic activity. The formation of faults is influenced by many different types of Earth processes which cause fault structures to vary between simple singular fractures to whole complex systems. What determines the extent and complexity of a fault system is the principal stress regimes that are applied to the rock layers and their physical resistance to these stresses. In this section I review stress regimes that drive fault mechanics and discuss some of the basic structures observed in faulted systems.

2.6.2 Primary Stresses

There are various Earth processes that contribute to the formation of faults in the upper lithosphere, but one of the most influential components of fault formation is the orientation of primary stresses. Anderson in 1905 first proposed that there are three different types of fault movement named normal, reverse, and wrench (now called strike-slip). However, the mechanics that initiate these formations at the time were still unknown. Anderson (1951) proposed that fault movement and orientation was due to three primary triaxial compressive stresses that occur in the lithosphere. These stresses range in magnitudes and are always oriented normal to each other. Various labels are used to describe these stresses depending on the specific field of science one is working in, but in general, the maximum primary stress is referred to as σ_1 , intermediate as σ_2 , and minimum as σ_3 . These three primary stresses never remain in the same orientation, instead they switch between two horizontal planes (x and y) and a vertical plane (z). Whether a normal, reverse, or strike-slip fault is formed depends on which primary stress is oriented vertically (Anderson, 1951). When the vertical stress (σ_v) is equal to σ_1 a normal fault is formed, when σ_v is equal to σ_2 a strike-slip fault is formed, and when σ_v equals σ_3 a reverse fault is formed (Fig. 2.5).

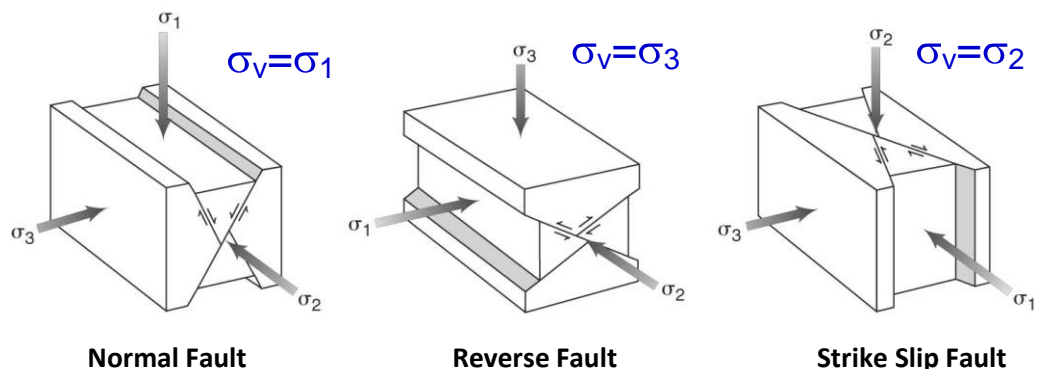

Figure 2.4. Diagram of Fault systems and their associated stress regime orientation. Fault represents a response of rock to shear stress, type is determined by which primary stress is oriented vertically.

The maximum compressional stress that initiates a fault system will always occur along σ_1 , while the responsive movement will occur along σ_3 plane because it is the weakest stress. Anderson's proposal was innovative and when combined with the Coulomb's Fracture Criterion a relationship between primary stress and approximate dip angle of the the different fault planes emerges (Healy et al., 2012). A normal fault plane will fail at or near 60° from horizontal, a reverse fault fails at approximately 30° from horizontal, and a strike-slip fault would fail at 90° (Simpson, 1997). With this hypothesis proving to have consistent results both in laboratories and in nature, Anderson's hypothesis has now become a widely accepted theory termed Andersonian Fault Mechanics (Fossen, 2010). In the following section the formation of faults and their general characteristics, orientations, basic structure and associated stress regimes will be discussed.

2.6.3 Formation and Propagation

All rocks contain small weaknesses such as microcracks, pores, clasts, cleaved mineral crystals, and other flaws. Griffith proposed in 1920 that stress will concentrate along these small features causing fracturing to occur at or near these imperfections (Simpson, 1997). Flaws that are oriented in respect to an applied external stress field have a higher likelihood of propagation and will expand more rapidly (Feng and Harrison, 2002). Faults will begin to form when local microfractures begin to interact and link with one another, forming what is called a macrofracture (Reaches and Lockner, 1994). Slip occurs along these micro- and macrofracture planes as means to relieve stress (Feng and Harrison, 2002; Anderson, 1951). Large amounts of stress accumulates at the tips of fractures at both scales. Just in front of the fracture tips a high concentration of microfractures and cracks will begin to form under the high stress conditions, causing the rock in this area to soften and be more prone to

failure. This region of softening is called the process zone and it is where faults will propagate (Reaches and Lockner, 1994). However, as not all fractures continue on forever. As fractures progress in development they can sometimes split causing them to either change orientation or become arrested (Gudmundsson et al., 2010). When a fracture does spread it can take a split to form a series of small fractures. A series of splayed symmetrical shear fractures is called a splay and a series of asymmetrical shear fractures is called a horsetail. Tensile fractures spreading fractures are called wing crack and a series of semi orthogonal shear fractures not connected to the tip is called antithetic shear fractures (Fossen, 2010).

2.6.4 Fault Cores and Damage Zone

A fault can be broken up into three general zones each with distinct material properties and behaviours (Fig. 2.6). The fault core is the focal area where slip and deformation occur. The thickness of this zone can vary extensively in size depending on rock types and discontinuities present near the plane (Gudmendsson et al., 2010). The fault core contains low permeable materials such as breccias, cataclasites, pseudotachylytes, and other crushed or altered rock material that can be defined as fault gouge (Evans et al., 1997; Gudmendsson et al., 2010). Motion occurs along this region in order for relieve the stress that has accumulated (Anderson, 1951). Surrounding the fault core is the damage zone. The damage zone consists of heavily fractured rock, large breccias, and a shear fracture that are hydroconductive (Evans et al., 1997). Often fluid flowing within the damage zone will cause minerals to form in the fractures. Progression of the fault plane or system often occurs in pulses over short distances. During each pulse slip will occur along the failure plane first and propagate outward into the damage zone and surrounding rock. As one moves further away from the fault core the concentration of brittle deformation in the damage zone will dwindle and the existing geology will, in some cases, start to show ductile deformation called drag folding (Gudmendsson et al., 2010).

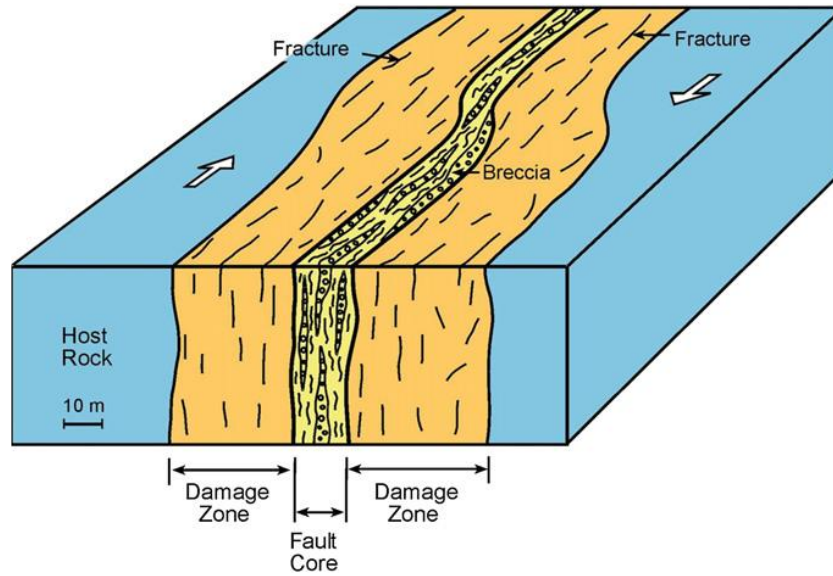

Figure 2.5. Cross section of fault trace to showing the designated deformation zones (Gudmendsson et al., 2010).

Fault termination and propagation depends on the stress field acting on the system as well as the rock type, layers and discontinuities between the surrounding affected geology. When a fracture meets an interface or discontinuity the propagation fracture with either stop, deflect along the existing weakness, or penetrate past the preexisting weakness into the existing intact rock or the next layer (Fig. 2.7). If the stress field is aligned with the stress fields that originally initiated the pre-existing failures the fracture will more likely stop or be deflected. However, the stress field acting on the system has changed in orientation penetration will more past these existing fracture and formation of a new oriented fractures can occur (Gudmendsson et al., 2010).

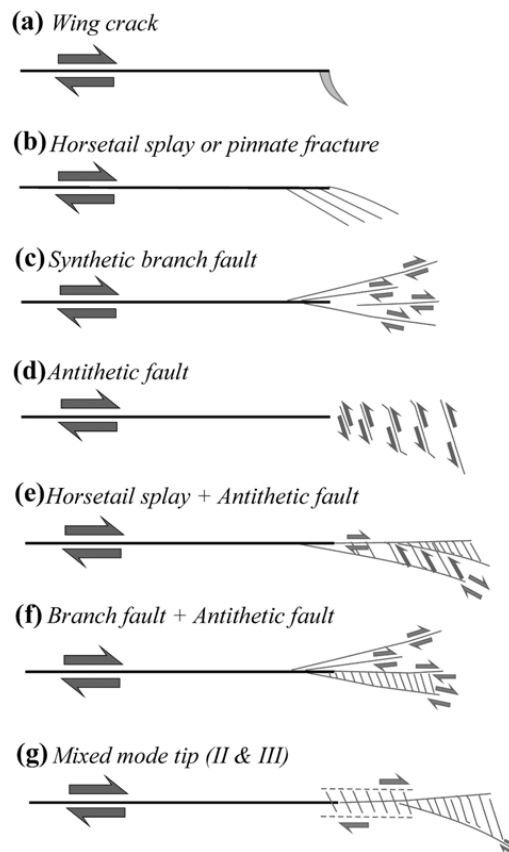

Figure 2.6. Diagram of different propagation fracture structures that can form in both faults and microfractures. A) Tensile wind cracks. B) Shearing Horsetail splays. C) Shearing splay (branch) fractures. D) Antithetic shear fractures (Kim et al., 2006)

2.6.5 Fault Zones and Conjugates

Often multiple subparallel faults can form in a region called a fault zone, due to the active primary stresses forming multiple fault traces (Fig. 2.8). Secondary minor fracture planes, called antithetic and synthetic faults, can also form near these main fault traces, which may cause confusion when trying to determine the orientation of σ_1 active in the region. When such formations occur it is important to determine which segment is the master fault and which are synthetic or antithetic faults. A master fault is the largest and most pronounced fault trace in the area. Synthetic faults are secondary minor faults with fracture planes parallel with the master fault. Antithetic faults are secondary minor fault traces with planes dipping opposite of the master fault. The coulomb fracture criterion predicts that conjugate faults form symmetrically around σ_1 . Sometimes two symmetrical faults with opposing dip directions will develop together creating a conjugate fault system. Examples of conjugate faults systems are synthetic faults, antithetic faults, and horst and graben systems (Fossen, 2010; Fig. 2.8).

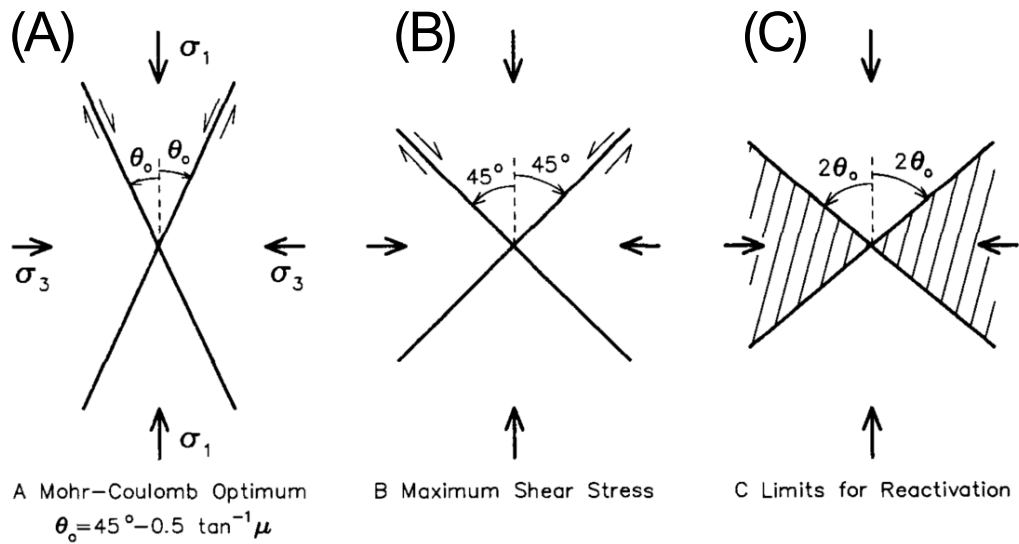

Figure 2.7. Diagram from Thatcher and Hill (1991) showing variations in conjugate faulting as primary stress continue to act on a failed system.

2.6.6 Normal Faults

Normal faults are associated with tensional stress regimes, where σ_1 is vertically oriented, and σ_2 and σ_3 are horizontally oriented along the x and y plane. The fault will form at approximately 60° from the horizontal plane and tensile motion will occur along the σ_3 plane (Anderson, 1951). Normal faults commonly occur in divergent plate boundaries, extensional rift valleys, and relief bends. It is theorized that the primary force driving tensional faulting is gravity, but some studies propose that the upwelling of hot magma from the mantle also may contribute to extensional forces (Wernicke and Axen, 1988).

A normal fault can form as a single failure, but more often multiple systems are formed to create a fault zone. These fault zones contain structural features such as horsts, grabens, listric faults, half grabens, domino faults, expansion cracks, and relay ramps (Jackson and McKenzie, 1983; Fig. 2.9). Horsts are high blocks that have two normal faults planes dipping away from each other whereas grabens are low lying blocks with two normal faults dipping toward each other. Horst and grabens normally occur together, but there are systems that contain half grabens where only one fault plane is present and the hanging wall sags toward the footwall (Fossen, 2010). Half grabens can either possess a regular planar fault trace or a curved listric fault (Gibbs, 1983).

2.6.7 Listric faults

At the surface normal faults can possess a planar fault trace with high offsets. However, seismic evaluations of normal faults planes show that normal fault planes often shallow at

depth forming a listric fault (Jackson and McKenzie, 1983). The curved fault plane can form due to geometric constraints, weaker geology at depth, or changes in rock rheology due to the presence of higher heat regimens existing in the deeper lithosphere. Jackson and McKenzie (1983) proposed that gravitational influence alone can cause movement along listric faults, but other studies have shown that listric faults can also form during crustal extension from isotropic rebound or mantle upwelling (Wernicke and Axen, 1988). Listric faults form due to extensional displacement. The displaced rock mass creates a half graben with a rollover anticline and often possesses a series of antithetic and synthetic faults either with curved or planar surfaces (Wernicke and Burchfiel, 1982; Gibbs, 1983; Fig. 2.8).

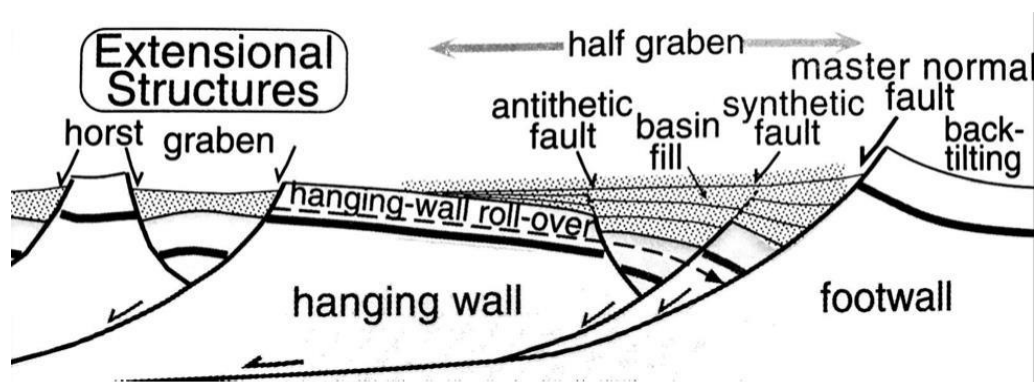

Figure 2.8. Cross section of listric fault with accompanying domino structures, synthetic faults, and antithetic faults (Burbank and Anderson, 2012).

2.6.8 Reverse Faults

Reverse faults are the opposite of normal faults with σ_1 oriented along a horizontal plane and displacement occurring along the vertically oriented σ_3 plane (Anderson, 1951). The failure plane forms at approximately 30° to the horizontal plane, but higher reverse fault planes can form along reactive normal fault planes. Reverse faults move over long distances and are the main contributors to orogenic process (Elliott, 1976). The basic fault structure is composed of flats and ramps. The flats are the initial horizontal sections of the geology prior to fracturing and the ramps are the plan which the thrust occur, connecting the flats together. Faults can be either planar or S-shape, a structure referred to as a horses. When a sequences of horse are compacted together they form a duplex and a series of planar thrust faults is called an imbrication (Butler, 1982). As imbrications and duplex compound during deformation they will form a whole wedge of deformation. The front end of this deformation zone is called the foreland and the back section is called the hinterland (Elliott, 1976). The two zones are separated by deformed rock from the basement material, and is called the decollement meaning detachment.

2.6.9 Strike slip Faults

Strike-slip faults are unique because both σ_1 and σ_3 occur along horizontal planes and σ_2 is oriented vertically. Due to these stress orientations the failure plane develops to be at or near vertical, along the σ_2 axis plane, and the failure has pure shear displacement (Anderson, 1951). Strike-slip faults can extend over long distances and often serve as a link between collisional or extensional faults by transferring the displacement between the two (Fossen, 2010). Another unique feature about strike-slip faults is their ability to express both extensional and contraction formations along their fault traces due to bends along the fault strike. Often these bends can produce transpressional and transtensional movement creating a unique series of structural features. Release bends are associated with transtensional movement, and will produce a series of extensional features, such as normal faults or negative flower structures. Releasing bends are often associated with the formation of small basins located long or next to the fault trace. Restraining bends, associated with transpressional movement, are the opposite. They may contain a series of subparallel reverse faults and can form positive relief structures such as positive flower structures (Kim and Sanderson, 2006; Fig. 2.9).

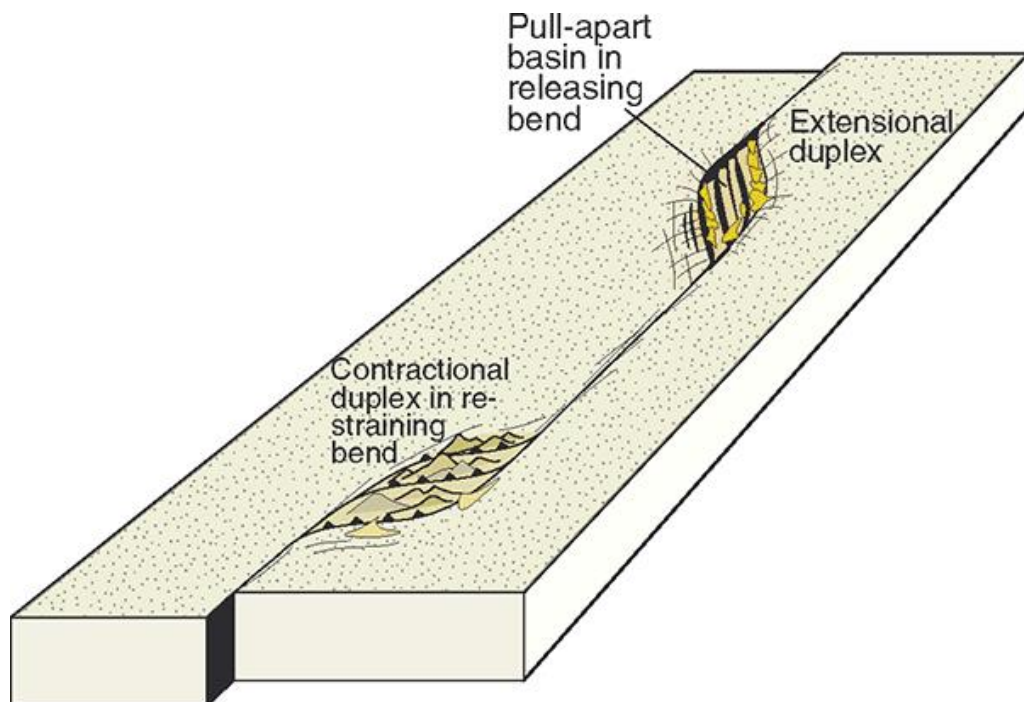

Figure 2.9. Diagram from Fossen (2010) of a strike slip fault with both relief and straining bends to show the dynamic structures that form in transpressional and transtensional areas.

Transpressional and tensional stresses also allow the release of stress in regions with pre-existing failures that are experiencing reactivation with stresses oriented non orthogonally. Eventually smaller failure features formed in these release and restrain bends will be linked

to the major fault trace creating a direct failure plane (Henza et al., 2010). Strike slip faults also accommodate stress regimes that are not oriented normal to the failure plan, such as in region of fault reactivation.

2.6.10 Relay Ramps

Sometimes fault systems will create two offsetting fault planes that will begin to expand and overlap one another. As the tips pass one another the zone in between them will begin to fold creating a relay ramp (Fig. 2.12). When the two faults eventually connect the relay ramp will break forming a structure called a breached relay ramp. Breaching of relay ramps can cause a fault plane to develop curves and bends (Peacock and Sanderson, 1991).

Terminology of restraining (contractional) and releasing (extensional) stepovers and bend along a dextral strike-slip fault

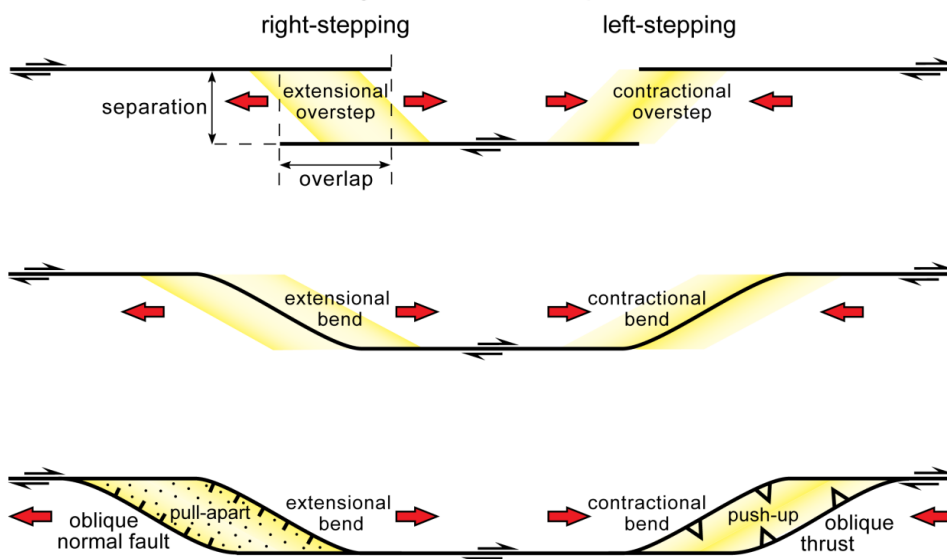

Figure 2.10. Diagram showing how offset fault lines create step over faults resulting in the formation of extensional systems or uplift (Fossen, 2010).

2.7 Tectonic Geomorphology

Tectonic geomorphology is an area of study that examines how tectonics influence surface processes. It is key to understanding the structural history of soft-sediment filled basins in particular because the underlying structural geology, though hard to see, can be expressed in the topography. These expression can also affect river and drainage patterns (Schumm et al., 2000; Burbank & Anderson, 2012). Tectonic geomorphology has become a hot topic in the earth sciences because it can provide further information and evidence for tectonic activity in regions where it was otherwise hard to study. This is partly because the time it takes for landscapes to change due to tectonic influences can vary from a matter of days to millions of years allowing scientist the ability to use landscape features as a tool to measure seismic activity (Burbank & Anderson, 2012). One of the more heavily researched

topics in tectonic geomorphology is how active tectonics have influenced drainages, catchments, and rivers. Drainage systems of all types are important because the constant provision of water helps the systems to adjust when changes to the surface have occurred (Schumm et al., 2000). Drainages also act as linear structures that can be used for measuring temporal changes associated in land movement (Schumm et al., 2000; Burbank & Anderson, 2012). Features such as such as river terraces, channels, floodplains, drainage patterns, and both cross sectional and long drainage profiles can all be used to evaluate tectonic influences (Fig. 2.11).

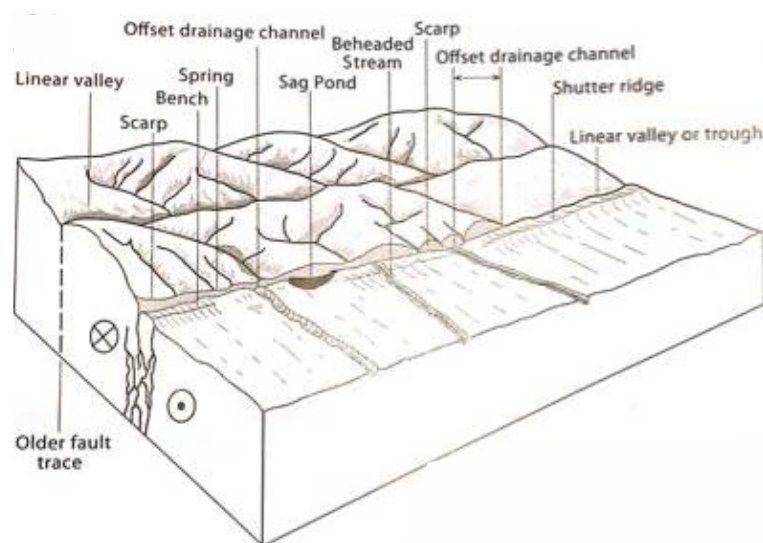

Figure 2.11. Model of different types of geomorphic features that can form due to tectonic influences, from Burbank and Anderson (2012)

2.7.1 Drainage Patterns

Depending on the regional slope angle and the surface material, catchments and their tributaries can form particular patterns (Schumm et al., 2000). Howard (1967) was one of the first to describe these patterns and the varying geomorphological factors creating them (Fig. 2.12). A rectangular drainage pattern is when a drainage forms a series of near orthogonal bends and forms due to water exploiting areas where the underlying geology is weakest or disrupted such as along discontinuities, faults, and joints (Howard, 1967; Fryirs and Brierley, 2013; Fig 2.12). Rectangular drainages can also result from episodic disruptions causing drainages to either be diverted or captured (Schumm et al., 2000; Burbank and Anderson, 2012).

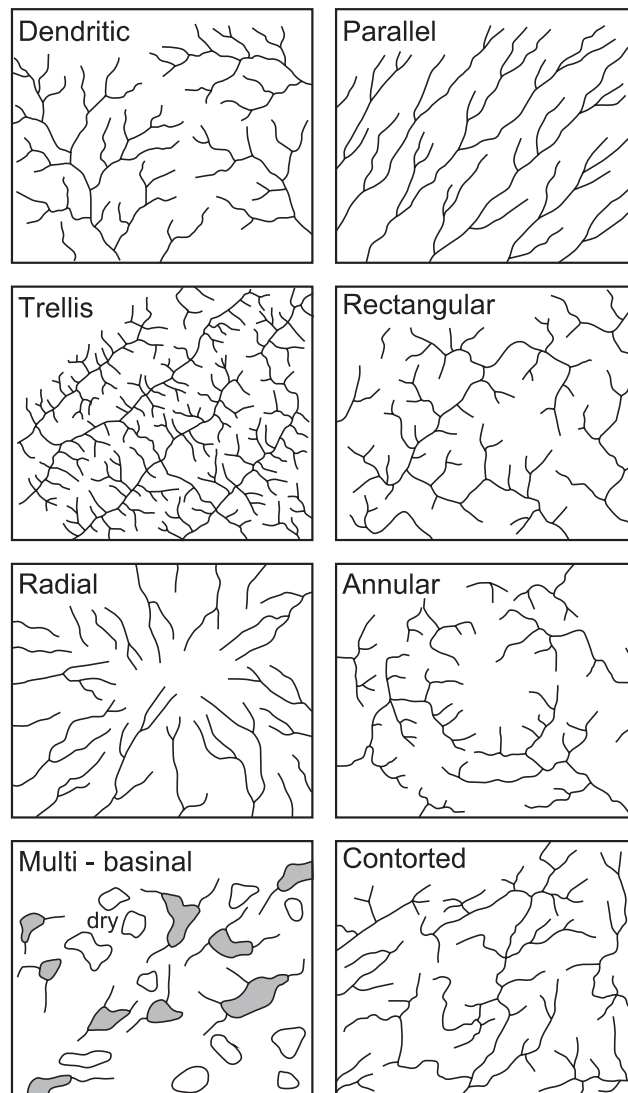

Figure 2.12. Variations of drainage patterns from Howard (1968).

2.7.2 Knickpoints

A Knickpoint is an area along a river channel that contains a dramatic change in gradient (Huggett, 2007). These changes can either be influenced through changes in climate, lithologies, or through the influence of active tectonics. In the case of knickpoints influenced by active tectonics when uplift or down drop happens the base level of the system changes causing a drastic change in slope along the river and downstream incision to occur (Ouchi, 1985; Schumm et al., 2000; Burbank & Anderson, 2012; Fryirs and Brierley, 2013). Evidence for knickpoints in geomorphology can be seen by the presence of waterfalls, long profile data, and sudden constriction of a river coupled with a transition from an aggradational zone to degradational zone (Ouchi, 1985; Schumm et al., 2000; Burbank & Anderson, 2012; Fryirs and Brierley, 2013).

2.7.3 Aggradation and Degradation

Many factors contribute to a river's ability to become incised or aggrade. Variables such as

a river's flux, sediment flux, type of sediment, and the strength or roughness of the river bed material can contribute to a river's ability to aggrade or degrade (Schumm et al., 2000; Burbank and Anderson, 2012; Fryirs and Brierley, 2013). However, one of the largest factors that can control aggradation and degradation is changes to the gradient of the river's flow path (Schumm et al., 2000; Burbank and Anderson, 2012; Fryirs and Brierley, 2013). When a gradient of a stream is increased a river will adjust through degradation causing incision and bank erosion to occur (Burbank and Anderson, 2012). When the gradient of a stream is shallowed through uplift or blockage the stream will slow and adjust either by altering its flow path around/along the obstruction or if it is completely cut off it will flood to form a lake (Schumm et al., 2000; Burbank and Anderson, 2012). Degradational areas contain knickpoints along river profiles and often display steep river slopes due to entrenchment. Areas of aggradation on the other hand contain shallower and broader channels that are either braided or more sinuous (Ouchi, 1985; Schumm et al., 2000; Fig. 2.13 drawing of example from Ouchi).

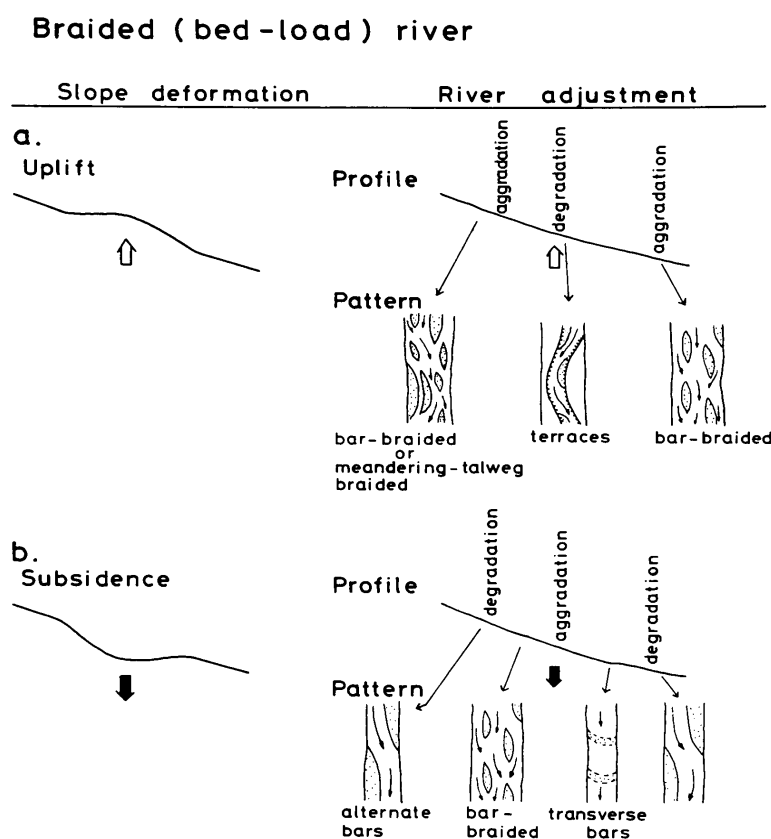

Figure 2.13. Experimental fluvial adjustments to systems experience uplift or subsidence from study conducted by Ochi (1985).

Tectonics can also influence aggradation and degradation of a river system by changing the gradient along a flow through fault displacement causing other channels to either become captured, avulsed, or altered (Schumm et al., 2000; Burbank and Anderson, 2012; Fryirs

and Brierley, 2013). If a river is flowing in the direction of a dipping fault plane, areas that experience rifting will result in the river further entrenching itself along the footwall and aggrading along the hanging wall (Ouchi, 1985, Schumm et al., 2000). If the same river with the same direction of flow experiences uplift the hanging wall will abstracture the flow path causing aggradation to happen along the footwall and the flow to either divert its direction along the fault plane or become a lake. Once the river is able to erode the obstruction an increases in aggradation will then occur along the hanging wall (Ouchi, 1985, Schumm et al., 2000; Fig. 2.14). If the direction of flow is opposite to the dip direction of the fault plane these signatures will be switched. It is important to note that the rate of deformation is also important to consider. Rapid events can cause incision and prevent lateral shift, whereas slow or creeping deformation will allow a channel to adjust by bending or widening (Ouchi's and Jin's experimental results (Schumm, 2000).

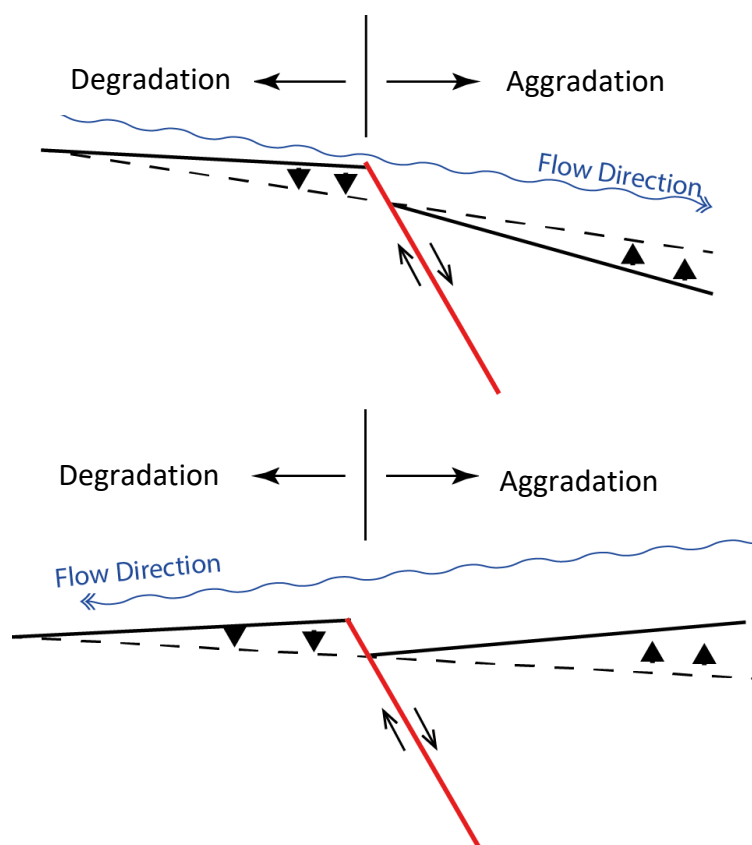

Figure 2.14. Diagram showing how river direction across a fault plane can result in different areas of aggradation and degradation. Diagram is based on similar one by Schumm et al. (2000).

2.7.4 River terraces

River terraces form when an alluvial system changes from a state of aggradation to degradation. Terraces are helpful features because they tell the story of when and where a paleoriver channel and valley floor once existed (Huggett, 2007, ch. 9; Fryirs and Brierley, 2013). Terraces can form both as paired and unpaired features. An unpaired terrace forms

when a river moves laterally faster than it can incise into the underlying geology. Paired terraces form when a river incises faster than it can move laterally (Huggett, 2007, ch. 9; Burbank and Anderson, 2012; Fryirs and Brierley, 2013; Fig. 2.15).

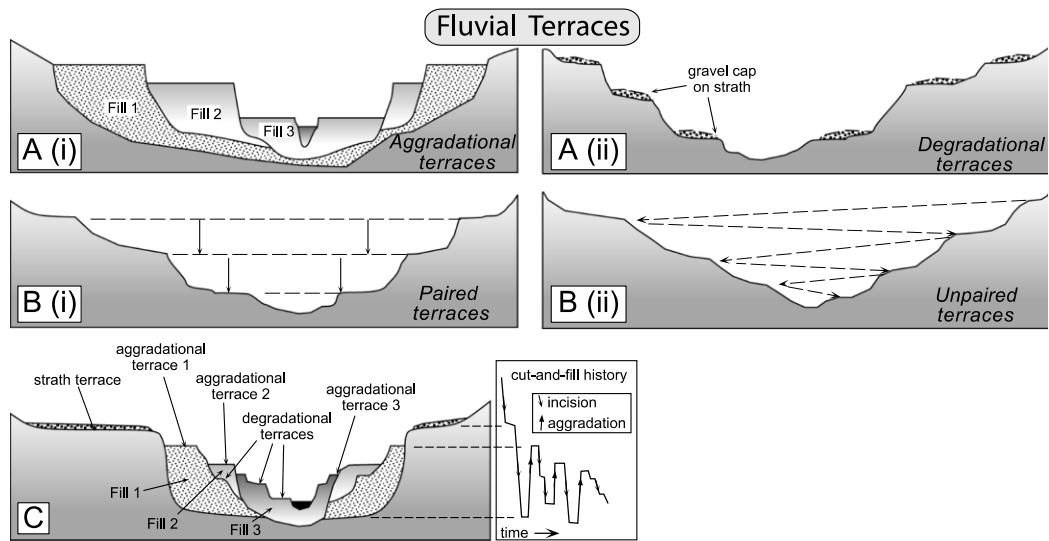

Figure 2.15. Diagram from Fryirs and Brierley (2013) showing variation in fluvial terraces.

2.8 Regional Faults

The major faults that surround the Hamilton Basin are the Wilton, the Waipa, and the debated Taupiri Faults (Kirk, 1991; Edbrooke and Begg, 2005). Though these faults have been identified little is actually known about them such as their full orientation, complete structure, and movement history (Kirk, 1991). For example, the orientation of the Waipa Fault was only considered within the past 30 years after the discovery of the Junction Magnetic Anomaly, and the Taupiri Fault was proposed to explain the Hakarimata Anticline's displaced orientation compared with the rest of the Kawhia Syncline (Hunt, 1978; Kirk, 1991). Of the limited information regarding the faults, what is known about them is that the major NNW oriented faults are tilted toward the west, and the secondary NE oriented faults are linked to a block faulting system (Kear and Schofield, 1978; Laird, 1993). There is evidence of strike slip movement occurring along several fault traces that precedes normal block faulting (Laird, 1993; Edbrooke et al., 1994). However, there is also evidence showing that such movement persisted into the Tertiary and possibly even beyond, such as vertical the offset of the Waikato Coal Measures and the varying thickness of their deposition (O'Brien and Rodgers, 1973; Kear and Schofield, 1978; Kirk, 1991; Edbrooke et al., 1994). It is also known that during the Middle to Late Miocene many of the major Late Cretaceous faults were reactivated as normal faults (King, 2000). Secondary NE trending fault systems also developed at this time but terminate against the major Late Cretaceous fault traces (Edbrooke, 2005). These systems acted as transfer faults between

the major traces and were later reactivated as normal faults during the Cenozoic (Laird, 1993).

2.8.1 Waipa Fault

The Waipa Fault is the largest, and possibly the most influential, of the major faults surrounding the Hamilton Basin. The fault was first inferred by Kear in 1960 to mark the boundary between the Murihiku Terrane and the Waipapa Composite Terrane, but confirmation of the trace did not come until the discovery of the Junction Magnetic Anomaly (Kear and Schofield, 1978; Hunt 1978). Most of the Waipa Fault's location has been inferred from this anomaly because there are few locations where its active scarp can be physically and geologically observed at the surface (Edbrooke, 2005). Though there are a few ophiolite outcrops are present within the North Island near the Waipa Fault, the presence of serpentine and the Junction Magnetic Anomaly imply that ultramafic rocks belonging to the Dun Mountain-Maitai Terrane are squeezed and buried along the fault line (Davy, 1993). The most notable serpentine deposit is near Piopio, where the deposit outcrops along the Waipa Fault. The serpentine deposit at Piopio was highly sheared along the strike direction of the fault, and offset of the surrounding younger Tertiary deposits indicate the fault has experienced reactivation (O'Brien and Rodgers, 1973; Eccles et al., 2005). The fault is a terrane suture that formed around the middle Triassic when the Dun Mountain-Maitai Terrane was thrust upon the east coast of Gondwanaland (Ballence and Campbell, 1993; O'Brien and Rodgers, 1973; Mortimer, 2004). It was reactivated in the Late Cretaceous and continued to be active at least into the Tertiary. The fault is oriented N to NNE and contains a near vertical to steeply westward dipping plane. A series of NE oriented block faults splay from the main trace within the lower Waikato and Northern Hamilton Basin region (Kear and Schofield, 1978; Hunt, 1978; Kirik, 1991; Edbrooke and Begg, 2005). The Hakarimata-Taupiri Ranges strike at a similar orientation to these secondary faults, but are composed of Murihiku Basement rock that have been folded into an anticline (Kear and Schofield, 1978). The strange orientation of the ranges implies that there must be a similar trending (the Taupiri Fault) near the ranges, but the movement that caused this arm of the Kawhia Syncline to become reoriented is still difficult to explain (Kear and Schofield, 1978; Hunt, 1978; Kirk, 1991).

2.8.2 Taupiri Fault

Hunt (1978) proposed that the Hakarimata-Taupiri Ranges were possibly emplaced by gravity slide while Kirk (1991) proposed that the ranges were possibly emplaced by dextral shear along the Waipa Fault, causing the formation of a secondary NE oriented Fault,

named the Taupiri Fault formed to help accommodate for space (Fig. 2.16). Evidence for this right lateral dextral movement comes from the rotation of the Hakarimata anticline as a coherent unit along a vertical axis (Hunt, 1978; Krik, 1991; Edbrooke et al., 1994). Further evidence of this non disturbance came from strike and dip measurements along the Hakarimata block where bedding structures show a connection between the Main Murihiku axial range and the Haka block (Kirk, 1991). What is strange is that the JMA is not deflected by the rotation of the Hakarimata Anticline showing the boundaries between the Murihiku-Waipapa terrane persists beneath the rotated block. It has been proposed by Kirk (1991) that at the location of the rotation the Murihiku Terrane is relatively thin possibly detached along a shallow horizontal shear surface. The Taupiri fault is indicated to be a possible normal fault with a plane dipping to the south that acts as a binding fault in the north section of the Hamilton Basin (Kirk, 1991).

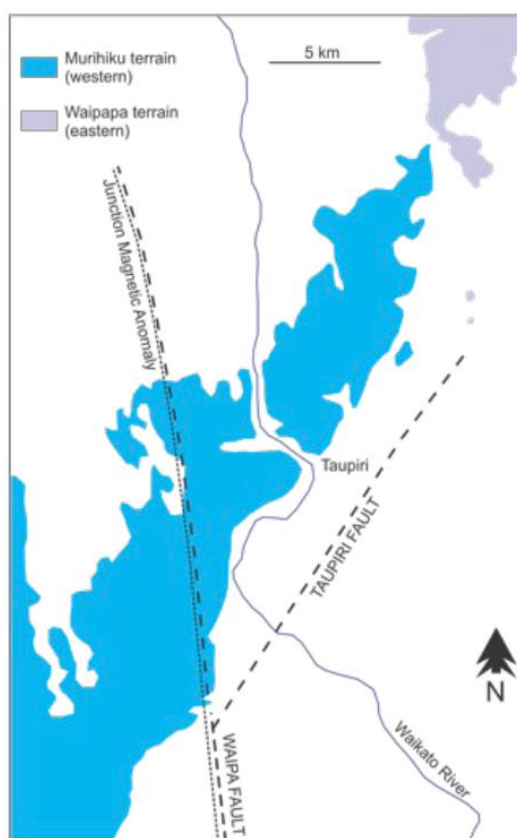

Figure 2.16. Diagram showing the Taupiri Fault's location as it relates to the Waipapa Fault and the Hakarimata Ranges, from Kirk (1991).

2.8.3 Kerepehi Fault

The Kerepehi Fault is an NNW oriented active fault located within the Hauraki Rift. Cross section analysis conducted by Hochstein et al., (1986) revealed that the fault extends into the basement rock that is buried below kilometers of unconsolidated sediment within the Hauraki Plains and possess both a normal and strike slip motion (Hochstein & Ballence,

1993; de Lange and Lowe, 1990; Persaud et al., 2016). The fault is tilted westward and moves as a hinge with the highest offset and motion occurring at the centre of the fault line (de Lange and Lowe, 1990; Persaud et al., 2016). Total displacement of the basement is about 1.1 to 3.5 km and the slip rate is between 0.08 to 0.4 mm per year (Hochestlin & Ballence, 1993; Persaud et al., 2016). Though the Hauraki Basin is separate from the Hamilton Basin, it is composed of almost completely identical geologic material, such as the Hinuera Formation and Waipapa Composite Terrane (Delange and Lowe, 1990; Persaud et al., 2016). The Kerepehi Fault does not directly influence the Hamilton Basin, but it can still be used as a parallel for examining soft sediment reactions to seismic activity, particularly the Hinuera Formation. Persaud et al. (2016) observed branching fissures within non-consolidated sediment layers and later found they were formed at different times, possibly from different events. They concluded that these branching deposits were formed during strong distal seismic events and were later cross cut by dominant fissure tracks that were formed during more locally occurring earthquakes. These deposits are showing that sediment can be disturbed by earthquakes that did not originate nearby.

2.8.4 Wairoa Fault

There is limited detailed information regarding the Wairoa Fault except that it is an N-S oriented active normal fault. The Fault has several sections which have been clustered into regional groups of North and South. The fault has a westward dipping plane between 50°-70° and up to 70m of offset has been observed along the fault. It was believed to have been reactivated between the Late Miocene to Pliocene as a result of oblique-tensional tectonic movement in the area (Wise et al., 2003). Limited information regarding this fault is due to its burial by recent sediments. However, Wise et al. (2003) conducted one of the most comprehensive studies along this fault using resistivity, seismic reflection, gravitational measurements, and later trenching along the fault line in order to inquire about the fault's structure that would be otherwise hidden.

2.9 Concluding Remarks

The Hamilton Basin is built upon the Murihiku, the Dun Mountain-Maitai, the Waipapa Composite Terrane, and the Te Kuiti Group. The basin is bound by Taupiri Fault in the North, and the Wilton and Waipa fault to the west. Though much is known about the basement terranes, information regarding the surrounding fault lines is limited. The Waipa Fault appears to have the strongest influence on the surrounding geology, but little is known about the fault. The Waipa Fault is a terrane suture that formed between the Early Permian to Mid Triassic and is associated with the ultramafic Dun Mountain-Maitai

Terrane. Horizontally sheared serpentine, found near the town of Piopio, and the rotation of the Hakarimata-Taupiri ranges give evidence that the fault was reactivated as a dextral strike slip fault around the Late Cretaceous to Tertiary. There is no evidence that the fault was moving later into the Paleogene, but it is possible that the acting deformation from the resulting changes in tectonic stresses shifted to a new fault line.

A series of secondary NE striking faults splay from the Waipa Fault, including the Taupiri Fault. These faults possess more of a normal block fault movement, but originated as transfer faults between the major Cretaceous aged faults like the Waipa. The fault traces found within the Hamilton Basin strike in a similar orientation to these secondary faults and they appear to be connected to the Waipa Fault. We know from physical evidence that these faults have been active within the past 20,000 ka, but what is unknown is the potential magnitude of a seismic event that can occur on these fault lines and how often they can occur. To better understand this we must examine the faults and gather information regarding their movement versus what we know about the surrounding major faults. It is possible that movement is occurring within the basement terranes and causing the unconsolidated sediments of the Hamilton Basin to undergo liquefaction. The goal of this project is to examine the inferred faults within the Hamilton Basin, as indicated by the geomorphology, seismic line data, existing borehole data, and geological and geomorphic ground-truth mapping. For this the history of the surrounding faults, such as their total offset and rate of occurrence, will be investigated in order to understand the behaviour of the faults within the Hamilton Basin and the potential hazards they can cause.

METHODOLOGY

3.1 Introduction

In regions that contain soft sediments, such as basins, active faulting can be hard to observe because the geology is poorly consolidated and can be easily eroded, reworked, and redeposited. In such locations tectonic geomorphology is key for evaluating the structural evolution of the area. The Hamilton Basin is one such location. This chapter outlines the remote sensing techniques and other methods used to examine the geomorphology of the Hamilton Basin for tectonic influences, with focus being given to the areas along the Waikato River. The Waikato River is a particularly important geomorphic tool because rivers act as linear structures and create other linear features such as terraces, floodplains, and channels that give insight into temporal changes associated with land movements (Schumm et al., 2000; Burbank & Anderson, 2011). With a basic understanding of fluvial geomorphology coupled with the use of LiDAR, multibeam imaging, gravitational, seismic, and sidescan data of the Waikato River an evaluation of tectonic geomorphic signatures within the Hamilton Basin could be conducted. The results gathered from these remote sensing techniques were used in selected regions of interest for further investigation via in field ground truthing.

Results gathered through desktop study and remote sensing data were used to select areas of interest for field investigation. The map area stretches along the Waikato River from the Narrows Bridge (37° 50' 30.7" S, 175° 20' 54.2") to the Older Horotiu Bridge (37° 41' 52.1" S, 175° 12' 19.9" E). The decision to select the Horotiu Bridge as the northern boundary for the field area was due to the existing knowledge of a normal fault scarp being present in a road cutting near the bridge. The decision to select the Narrows Bridge as the southern boundary was based on remote sensing and seismic data, which indicated the presence of a possible fault zone just above it near Stubbs Road. Though the LiDAR, multibeam and seismic data indicated that the area south of the Narrows Bridge may also have potential faulting the data also indicated that the system may be more complex than other areas surrounding it and there was not enough time to investigate it. The processes conducted both during field investigation and evaluating collected field data are discussed in the following chapter.

3.2 Remote Sensing

A high-resolution digital elevation model (DEM) derived from Light Detection and Ranging (LiDAR) was formed and provided by the Waikato Regional Council. LiDAR is an exceptionally important tool for evaluating geomorphology because it shows the underlying topography without disruption from buildings, vegetation, and other obstacles. Using the LiDAR data geomorphic features such as ridgelines, drainages, flood plains, terraces, abandoned channels, etc. could be observed. Using the LiDAR data in conjunction with ArcGIS cross section could be constructed and measurements could be taken from any area where data was available. Sections of the map could also be cut out and used to construct 3D elevation models in ArcScene to help view the topography and geomorphic structures at new angles. Mainly the DEM and LiDAR data was used as form of reconnaissance to search for field locations of interest where strong geomorphic faulting structures were present.

3.3 Multibeam

An extensive geomorphological survey of the Waikato River from the Karapiro Dam to Ngaruawahia was conducted by Wood (2006). For his research side scan sonar, sediment sampling, current velocity measurements using ADPs, multibeam scanning, and both cross sectional and long profiling was used to evaluate the bank stability along sections of the Waikato River. Wood's in depth research assisted in data collection, specifically the Multibeam scanning, long profiling, and 3D imaging construction of the Waikato River bed by combining the side scan sonar with the multibeam scans. The 3D images were used to evaluate the geomorphology along the riverbed and see if there was any displacements or discontinuities. Wood's results (2006) of where each multibeam and side scan was taken was also helpful to use for measuring the angles created by the geomorphic planar structures observed in the images and comparing them to angles between outcrops found in the field. Long profile results were used to measure depression structures found in the imaging along the riverbed.

3.3.1 Seismic DATA

A seismic reflection data was conducted down the Waikato River from Cambridge to Taupiri, by Moon and de Lange (2017) using a high resolution CHIRP Seismic reflector at 3.5 kHz in order to assume penetration into the river bottom sediments. Surveys were conducted in 10 minuet long section and position tracking was conducted using RTK GPS and notes taken by on observer on board. Water depth measurements were conducted using a transducer at 200 kHz. Data gather from the survey was processed using post survey

processing software. Discontinuities found in the data were initially determined using SeiSee.

3.4 Geophysical Data

3.4.1 *Pre-existing Seismic Reflection Data*

Seismic reflection data gathered during economic evaluations of the Waikato region in the early 70s was used to help gain more insight to the underlying geological structures. Results from these specific investigations were accessed from the NZ Petroleum and Minerals website (www.nzpam.govt.nz). Though these seismic surveys were advanced for their time when conducted, the technology was not as advanced as it is today, resulting in data having poor resolution. Another difficulty in using these seismic lines is that the reports detailing the scale and calibration used is missing causing the true scale to be undetermined. However, the depth and type of units could be determined thanks to well logs, specifically PR569. Using the seismic images and the well logs combined an estimation of the length of each of the seismic line could be calculated and plotted on ArcGIS. It must be advised that because of the scaling issue with these logs these seismic lines must be used as a helpful references rather than providing definitive locations of structures identified. A total of 24 lines were provided, of these Lines 569-2 and 569-16 were important to the field area due to their length, proximity to the Waikato River and their N-S orientation through the Hamilton Basin which allowed for cross cutting relations of faults to be seen. Seismic line images were interpreted using both print outs of the lines and with viewing them on Adobe Illustrator. To help cope with the poor resolution continuous segments in the data were searched for and marked with black pen line to help enhance the bedding structures for interpretation. Once bedding resolution could be improved structural features such as offset bedding and discontinuities in the planes of bedding could be identified. However, because of the poor resolution it is hard to tell what is truly offset or jointed and not just background noise from the instrumentation.

3.5 Field Survey Procedure

Standard geological mapping techniques were used to map the riverbank geology along the Waikato River using foot access where feasible and boat surveys when not. Location parameters of each site were recorded using a Garmin GPS and stratigraphic logs, sketches, photographs and measurements, including dips and dip directions were taken at all major outcrop and landform locations. If the lithology found in an area could not be determined while at the site samples were collected and later used for thin sections and Scanning Electron Microscope (SEM) evaluations to determine the unit type associated with the outcrop. Fault plane orientations were recorded using mobile application GeolD. Parallel

work conducted by Campbell (2017) investigated a large cutting at Kay Road on the northern margin of Hamilton City (37°42'40" S, 175°15'25" E) surveying fault planes exposed during construction. Information gathered from his study was used and compared to fault traces and data collected from this study. Two boat surveys and seven land based surveys along the Waikato River were conducted during the summer, when river levels would be near its lowest point and, at least what was hoped for, fairer weather. Boat surveys were launched from the ramp near Anzac parade on both days. The first day covered an area from north of the Narrows Bridge to just past Kay Road. The section boat survey included a revisit to the fault plane site near Stubbs Road and extended to the old Horotiu Bridge. Good exposed outcrops that could be within reach to sample were sought after for this survey. However, many sections along the bank have been heavily overgrown with vegetation. If an exposure was accessible the weathered areas would be scrapped with a nawashi to freshly expose the geology. The outcrops material types, physical structure, additional components, and if valuable grain size were examined. At some locations stratigraphic logs were taken for the areas of importance. On foot similar technics were used with additional assistance given through the use of 1.0 to 4.0m hang augers when available and the digging of holes or small trenches with a spade to better expose deeper bedding structures.

Due to the city of Hamilton experiencing development over the past 50 years with some of the more sought after real estate sections being along the Waikato River, many of the locations along the river have been greatly altered by earthworks in order to make way for houses and buildings. In these areas the original geomorphology has either been altered or completely removed. Layers associated with the Hinuera Formation were often the most affected out of all the geological formation, however large extensive amounts of fill often found along the river path proved to be the more frustrating urban alteration. The fill was a test of patience because many of the geologic contacts and outcrops became lost behind the hundreds of cubic metres of fill that have been pushed over the bank to make room for development. Even with the use of a spade and both 1.0 to 4.0m hand auger the original deposits were not able to be found in sections. Such locations where this occurred was through almost all of downtown Hamilton along the river path on both sides from the Hamilton Gardens to Day's Park.

3.5.1 Geological Unit Mapping

Using information regarding the existing geological signatures related to each lithological unit such as rock type, contained clast/minerals, and the presence of depositional structure

helped identify the different units. However, due to the Hamilton Basin being composed of volcanoclastic material that has been eroded, reworked and redeposited in places, extra care needed to be taken to look out for structures that at first may appear as an ignimbrite or sedimentary unit, but in fact would be the opposite. Notation of the geomorphology and how deposits contributed to particular trends in the landscape was also conducted in both on foot and boat surveys.

Structural features of interests included fault planes, drag folding, gouge deposits, iron staining/panning in fractures, offset bedding, or alternating geological units. Abrupt changes in topography or changes in rock type either exposed on the surface or across the river were also characteristics that were searched for. When dealing with poorly consolidated material fault scarps can be rather complex, but still maintain relatively simple morphological signatures such as reclined scarp faces and buried detachment faces (Nash, 2013). Finding the exact locations of such features along the Waikato River was often met with difficulty due to heavy changes to the geology through urban development, and heavy vegetation growth along many sections of the Waikato River.

3.6 Thin Sections

Samples were collected, air dried in a fume hood, resined to reinforce using K36 resin, cut into bullits, and ground into thin sections for further investigation. Thin Section Slides were examined using a microscope with using regular light and cross polar light. Samples that were collected are from areas in the field where the geology could not be determined. Results from these thin sections only include those collected from locations of importance, all other descriptions relating to thin sections can be found in the appendix.

3.7 Scanning Electron Microscope

Scanning Electron Microscope images were only collected for samples R2S8 Ash layer and R2S12 due to technical difficulties involving the microscope computers that caused it out of order during the investigation time. Due to this unforeseen issue and the limited time SEM images could only be captured for three samples. These samples were selected based on their challenging material composition, colour, and outcrop creating an uncertainty of its geology in the field. Due to this complication the results from these images will not be discussed, but the images are available in the appendix.

3.8 ArcGIS Mapping

All collected field information was compiled and organized into an excel spreadsheet. Details regarding the locations coordinates, their conversion from New Zealand Geodetic

Datum 1949 to New Zealand Transverse Mercator 2000, which side of the river bank the location was, samples collected, photos taken and other information was included in the spreadsheet and can be found in the appendix. A simplified version of the spreadsheet was created specifically to use for the ArcGIS. Field numbers are denoted as “R” for River boat surveys and “F” for on foot field surveys. Each conducted trip is numbered consecutively for each major location of field work. There is at least one photograph taken of each location with the exception of R1S3, R1S10, R1S11, R1S14, R1S22, and R1S28. The information from the spreadsheet was imported into ArcGIS and the coordinates of each location were plotted on a map of the Waikato River using the Transverse Mercator 2000 projection. The locations were then categorized based on their geological formation and type. Using the location data together with 1.0, 2.0, 2.5 and 5.0m contour map projections from the provided DEM a geological units map could be constructed. Some of the geologic units such as the ignimbrites, tend to have topographical signatures, such as steep tall slopes whereas Hinuera formation makes low lying topography. With such information and the location of other like formation nearby contacts and apparent contacts could be drawn. However given the limitations outcrops along the river more investigation is needed to determine their exact locations.

3.9 Concluding Remarks

In order to fully understand the tectonic history of the Hamilton Basin an understanding of its geomorphology needs to be done first. Through the use of digital elevation mapping processed into a LiDAR map allowed for remote sensing of the Hamilton Basin to be conducted. Specific features such as river terraces, drainage patterns, linear ridges and drainages, and stream capture/abandonment were all signature alluvial features that can give evidence for tectonic influences. Additional detailed geomorphology data provided by Wood (2006) was also used for the tectonic geomorphic evaluation of the Hamilton Basin through study of the Waikato River. Desktop study of the previously gathered geophysical data of the Hamilton basin was also used in conjunction to the LiDAR and geomorphic data in order to further investigate the tectonic history of the Basin. Results gathered through all provided information discussed in the chapter were then used to determine sites of interest for field investigation.

The geology present along the Waikato River was examined through standard geological surveying field techniques both on land and by boat. Particular areas that possessed a potential fault trace were first pre-evaluated using remote sensing techniques then followed up during the field examination. Each location was described and the geologic formation

was determined. If there was ambiguity regarding what formation was present at a field station samples were collected and made into thin sections for further investigation. SEM was also used, but due to technical difficulties examination was only conducted on two samples. Results gathered through from these expeditions were used to construct a geologic map using ArcGIS and then interpreted for tectonic evidence in the Hamilton Basin.

CHAPTER 4

RESULTS

4.1 Introduction

This chapter presents the results of the desk study, field surveying, and laboratory analysis undertaken during this study. Detailed supporting data are provided in Appendix I and II. Initially, results from remote sensing and assessment of pre-existing data sources are discussed. Following this, field and laboratory results are presented. For organization purposes field and laboratory results are broken into three main field groups based on key geomorphic areas defined by major bends along the Waikato River (Fig. 4.1). In each section, findings regarding the geomorphology based dominantly on the LiDAR data are presented first, followed by field, multibeam, and seismic data. It is important to note that the multibeam, magnetic, and gravity survey data were not produced by me for this study. Instead, findings regarding these surveys are from previous studies and are presented in this chapter as means to build the bigger tectonic and structural picture of the Hamilton Basin. Accompanying maps of the geomorphology, and geological units are presented for each section with labelled important geomorphic features, location numbers for particular outcrops of importance, and for some areas, borehole sites and descriptions. At the end of this chapter a summary of findings will be presented followed by presentation of features commonly found in all areas.

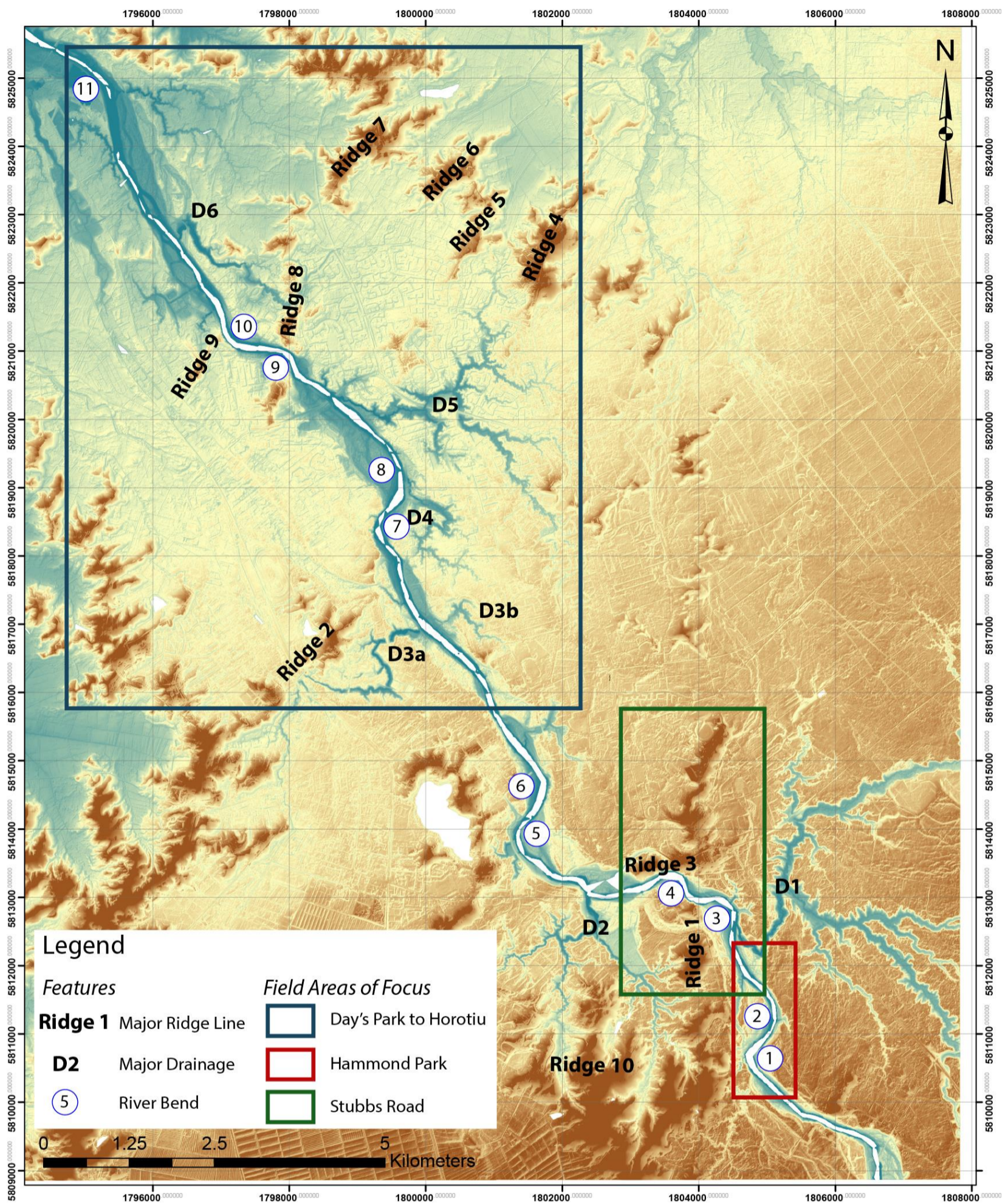

Figure 4.1. Colourized LiDAR map of the Hamilton basin from Tamahere to Horotiu. The brown represents areas of high elevation while the blue signifies low elevation. Hillshade effect with an elevation shading of 0.2m was used for this construction and all other LiDAR maps to follow. Major Ridges, Drainages, and River Bends are labelled for reference in this map. Field areas of focus are boxed in the blue, red, and green boxes. Note the similar trends that many of the ridge lines possess. For example, Ridge 1, 2, 8 and 9 intersect the Waikato River at river bends 3, 4, 7, 9, 10. The orientation of drainages and their catchments can also be observed in this map. Note that D1 has a catchment system with a dominate NW direction until it is cut off by a NNE tributary. A similar but less extensive form can also be observed for D5.

4.2 Remote Sensing

4.2.1 *Multibeam Data*

Wood's (2006) survey of the Waikato River bed geomorphology from the Karapiro Dam to Ngaruawahia provided important foundational information for this study. Results from Wood (2006) revealed 30 locations that contained constricted and/or meandering scour hole depressions associated with increased incisions into the underlying geology on the down river side. Half of these depressions are located along meandering bends of the Waikato River. When looking specifically at the section between the Narrows and Horotiu Bridges, there are 15 depressions, eight of which occur at meandering bends. Multibeam 3D images of the riverbed geomorphology were created by Wood (2006) from combining multibeam imaging with sidescan sonar results. From these 3D images changes in the geomorphology can be observed and infer that either the geology present have variability in induration, or perhaps there is a change in the lithologies present at the site (Wood, 2006). Wood (2006) averaged the scour shapes of these depression from the Narrows to Ngaruawahia and found that they had an average angle of exit slope ranging between 45°-65° and that the meander bends found mostly in the Hamilton City region are the deepest when compared to their surrounding land elevations with depressions between 2 to 4 metres (Wood, 2006).

4.2.2 *Gravity Survey Data*

Data from a gravity map provided by FrOG Tech (2001) shows a significant low gravity reading in the northwestern section of the Hamilton Basin near Ngaruawahia. This gravitational low section is oriented NE-SE and forms an elliptical depression within the basement structures that are infilled with low density sediments. Recordings for the deepest portion are located slightly north of Te Rapa (Fig. 4.2A). A secondary smaller basin to the east near Gordonton is also present and it is separated from the main lowest depression by a saddle of higher gravity readings (Fig. 4.2B). In the SE section of Hamilton City there is a sharp change in the gravitational properties where a saddle of medium gravity valued material is located near the Hammond Park area with a NNW orientation (Fig 4.2C). To the west of this feature, near the Melville, Glenview, and Fitzroy area, is a depression with similar orientation and a medium-low gravity.

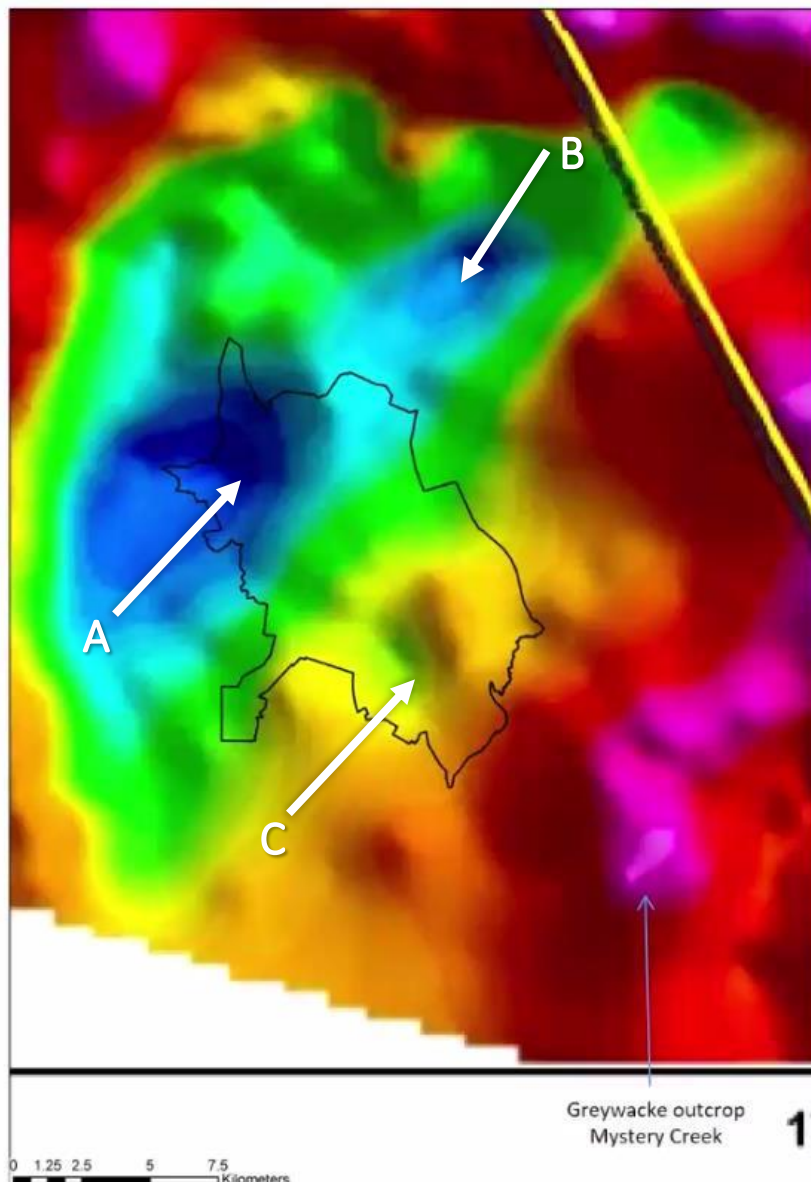

Figure 4.2. Gravity Anomaly Map of the Hamilton Basin from FrOG Tech (2001). The scale of the gravity values ranges from dark blue as low, indicating a depression in the basement filled with low density sediments, to pink as high indicating the upstanding basement. A) Indicated the lowest gravitational value forming a depression near Te Rapa. B) The secondary low gravitational value depression located near Gordonton. C) Third depression with a medium gravitational anomaly located near Melville, Fitzroy, and Glenview areas.

4.2.3 Older Seismic Data:

Though the resolution is low, certain structures can be observed in many of the seismic lines such as offset beds, wavy contacts between deposit layers, and large failures with what looks like shallowing decollements indicating the presence of listric faults. It is important to note that true offset cannot be obtained due to the poor quality of the seismic lines and scaling issues, but there are sections with better clarity where beds are clearly

offset. That being said, these lines are used for reference and observation rather than as measurable data for this project.

My interpretations, of Line PR569-2 (Figure 4.3, Line 2) shows a system of large failures that can be separated in seven zones (Fig. 4.3). Zone 1 consists of a shallow southward-dipping plane that seems like it may link to the others in this area. The discontinuities are generally near vertical, except to the south where one fault is dipping slightly to the north. Movement is hard to tell due to the quality of the seismic lines but it appears that in the northern section of zone 1 has dropped down toward the south, indicating a normal fault. Zone 2 contains several branching failures with additional lone failures. The whole zone appears to be sitting lower than the surrounding material indicating a graben structure. Many of these discontinuities seem like they could connect and be branching from a similar point, but again it is hard to tell with the resolution of the seismic line. Zones 3 is one of the largest areas of failure and the region with the best resolution in the whole of seismic line 596-2. Similar structures to the others previously mentioned are present. There is a main discontinuity dipping to the south with the steepest portion occurring in the upper material and shallowing in the lower material. Numerous branching faults with similar dips can be observed with some smaller near vertical and antithetic discontinuities. A large branch occurs in the northern most section of Zone 3 with a smaller branching system occurring the southern section. In between these two branching systems are a few singular failures. The offset seems greatest to the north and lowest in the south with the zone containing a listric fault structure (Fig 4.2). At Zone 4 are several near vertical faults that seem like they possible connect deeper into the geology. Zone 5 is another system with north-dipping shallow discontinuities, and a possible conjugate system. However, the resolution is low so it difficult to be sure. A flower structure is observed at Zone 6 with most of the failures having a near vertical orientation and occasional slightly northern dipping section. The last system at Zone 7 where a dominant fault with a shallowing northward-dipping plane is observed. From this plane are several smaller branching failures. Within the northern section it appears that there could be a major southward dipping discontinuity, but it is difficult to be sure given the poor resolution of the line. Overall Line 569-2 shows a large listric fault system composed of seven zones of failures. The system has a dominant normal failure toward the south and is accompanied by several areas of synthetic and antithetic faults and flower structures (Fig. 4.3).

Line 569-16 (Fig. 4.4, Line 16) has slightly better resolution, with the majority of the failures occurring in the southern section of the line between Zones 2 and 4 (Fig. 4.4 line 16). Zone

1 is a smaller system that appears to be branching with a dominant plane oriented to the south and normal movement. The plane shallows the deeper it goes showing another listric system (Fig. 4.4). Between zones 1 and 2 there resolution is exceptionally poor and nothing could be made from that area, but that is not to say that nothing exists there. Zone 2 has a main fault plane dipping to the south showing a half graben roll over structure with in the bed offsets (Fig. 4.4). The biggest zone of failure is Zone 3 which consists of multiple flower structures. Many of these structures are steeper in the upper portions of the geology and vary between northward and southward dipping planes in deeper within the geology, again indicating a listric system. In the northern section bedding offset appears to have section of down drop but also uplift showing that this system consists of a complex zone with antithetic/synthetic faults and possible conjugate faults. However, when comparing Zone 3 to Zone 2 it seems the two zones could be linked creating a dominant normal listric fault oriented with a southward failure direction. Zone 4 consists of an asymmetrical northern ward branching flower structure. Overall the trends observed between Line 569-2 and 569-16 is that both contain an overall listric structure, with accompanying synthetic, antithetic and flower structures. The systems appear to have a normal faulting to the south with multiple smaller listric failures creating an almost domino systems (Wernicke and Burchfiel, 1982; Gibbs, 1983; Jackson and McKenzie, 1983).

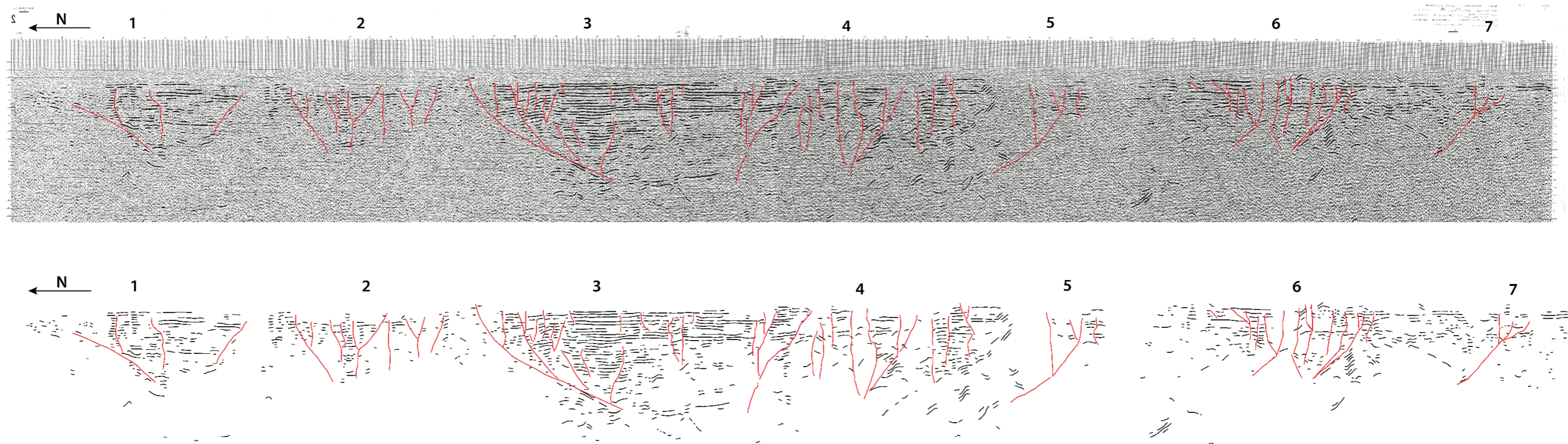

Figure 4.3. Seismic Line 549-2 with the upper half showing the original seismic line with the marked discontinuities and divided fault zones, and the bottom half showing the discontinuities without the seismic line for better visual observation. Notice that the many of the structures contain curved failure planes and flower structures, particularly in zones 3, 4, and 6.

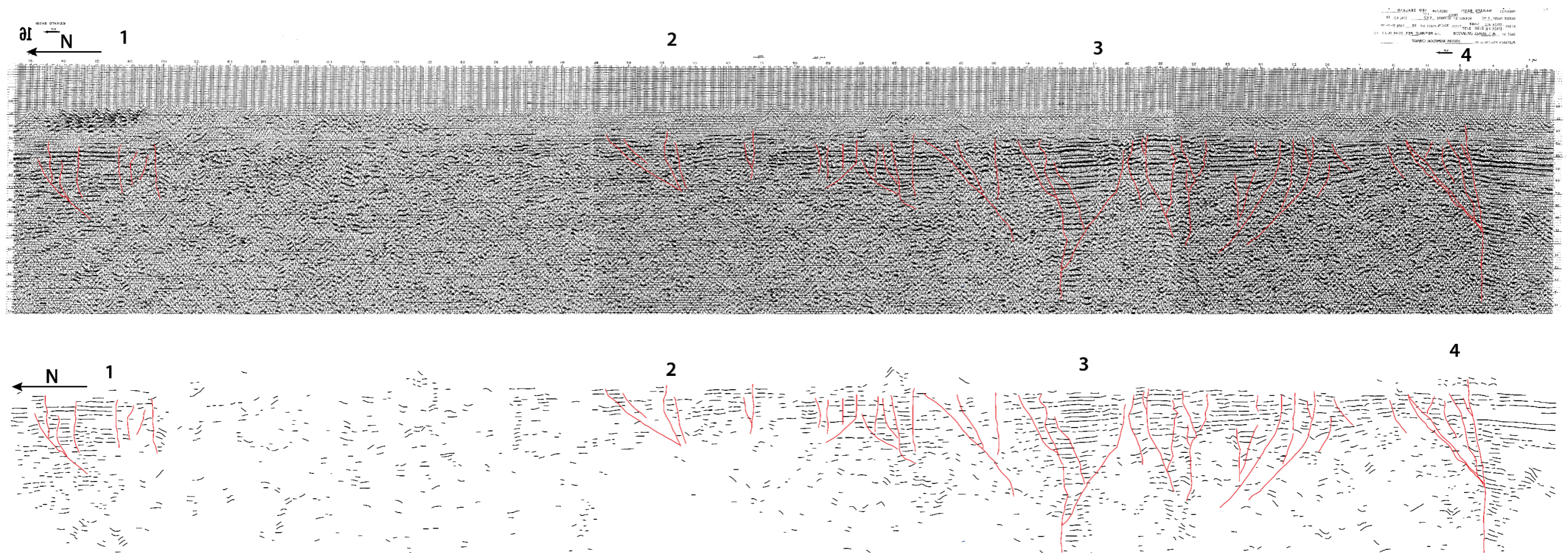

Figure 4.4. Seismic Line 549-16 with the upper half showing the original seismic line with the marked discontinuities and divided fault zones, and the bottom half showing the discontinuities with a clean background for better observation. Due to the resolution of the line the majority of discontinuities that are found are contained between Zones 2 and 4, but that is not to say more does not potentially exist in the northern section.

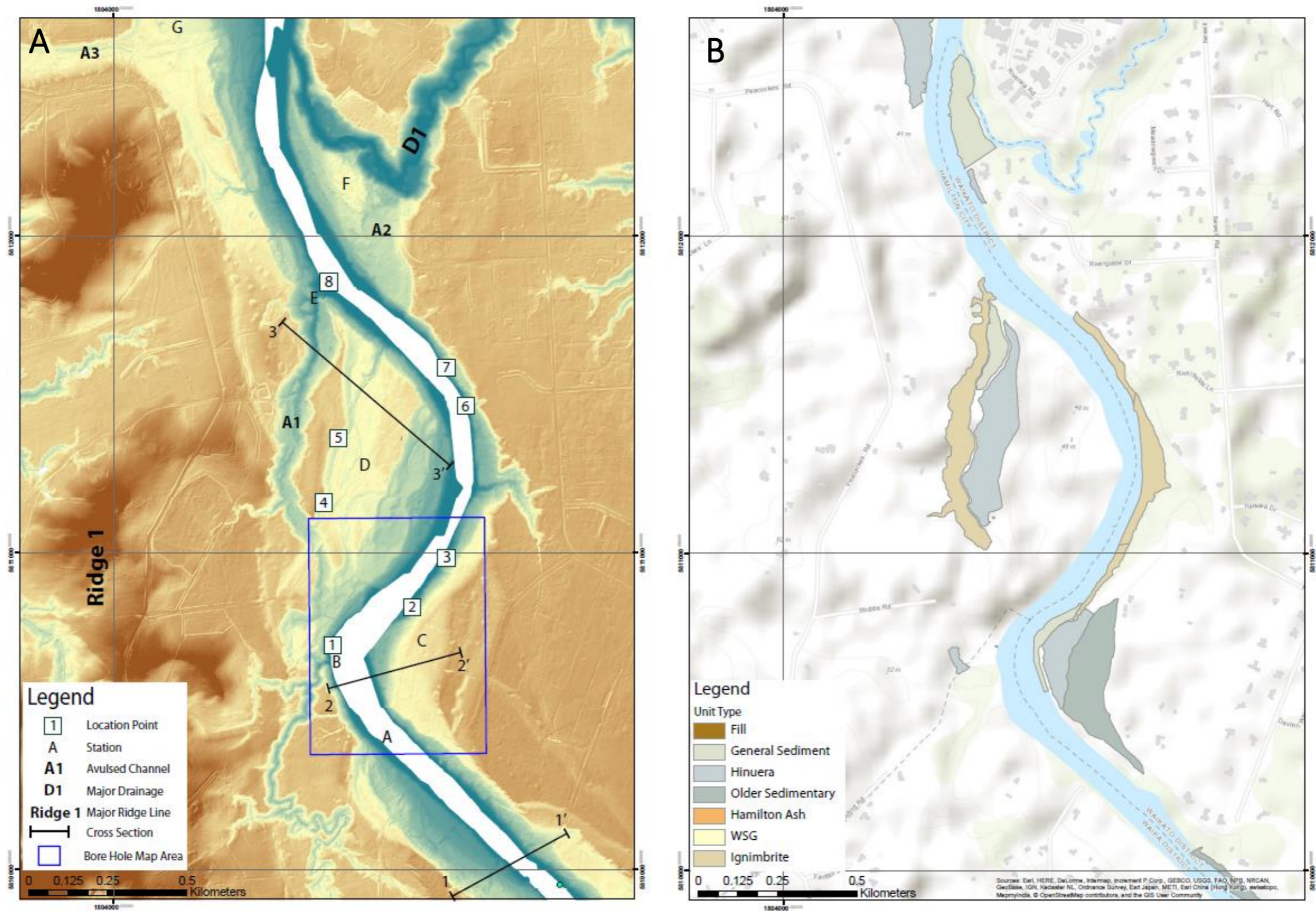

Figure 4.5. A) Geomorphic map of Stubbs Road. Major geomorphic features such as ridges, major drainage systems, avulsed/abandoned channels are shown. Important areas of interest in the field and from remote sensing are marked by station numbers. Locations with importance to field outcrops are marked by location numbers. Locations of additional investigations conducted through LiDAR cross sections and bore hole transections are presented on this map with specific results from these studies presented later on in this section. B) Geological Units map of Stubbs Road with all potential lithologies along the Waikato River presented in the Legend and mapped lithologies found in the field shown on the map.

4.3 Stubbs Road

4.3.1 Geomorphology

The Waikato River maintains a NW orientation as it progresses from the Narrows Bridge towards Stubbs Road. The river bends approximately 97° to the NE and then approximately 139° back towards the NNW, forming a large half-moon shaped terrace along the western bank (Fig. 4.5A; Table 4.1). As it continues downstream the Waikato River maintains a northerly orientation until it reaches Hammond Park. On the western side of the Waikato River between Stubbs Road and Hammond Park is a large north-south oriented ridge, Ridge 1, and on the eastern side is a set of southeast-northwest oriented drainages, D1, that are beheaded by a northeast-southwest tributary. Along the southern section of the Waikato River at Station A, LiDAR images show a set of paired terraces along the river (Fig. 4.6A). Near Station A the river channel becomes constricted, after the constriction the Waikato River forms a small single terrace along the eastern bank, marked by Station C (Fig. 4.6B). As the river wraps back around, creating the half-moon shape, three large terraces are present, with a fourth smaller one bordering the river (Fig. 4.6C). Each terrace decreases in height toward the east and a deep N-S oriented abandoned channel, A1, cuts into these terraces along the western outer most edge (Fig.4.5A).

Table 4.1. Table of measured angles of the major river bends (Fig. 4.1) occurring between Stubbs Road to Horotiu Bridge. These angles are approximate based on lines draw on down the main river path on GIS maps and then measured with a protractor

River Bend Number	Bend Angle
1	97
2	139
3	100
4	94
5	108
6	122
7	98
8	137
9	115
10	110
11	128
Average Angle	113

The channel width measures between 30-50m in the south near Station B and becomes 50-100m wide as it progresses to the north near Station E. Along the northern section of the abandoned river channel, near station E, a set of terraces can be observed, whereas at

the southern end near Station B there are no major terraces. The channel begins near Station B at the sharp bend in the southern portion of Stubbs Road and then links to the Waikato River in the north at Station E, showing that it once followed the alignment of the upstream N-S oriented section of the Waikato River before it reached Hammond Park. Located near Station F is a second N-S oriented gully system, D1, along the western bank that enters the Waikato River at the crest of the river bend north of Station F. This gully system not only aligns with the larger N-S channel along the western bank, but LiDAR images show an older abandoned outlet, marked A2, that is aligned with A1 (Fig. 4.5A). Along the eastern shore at Station C is a single terrace (Fig.4.6B). North of Station C is a peninsula shaped terrace, marked as Station F, with the outlet to D1 located just north at its tip. The LiDAR images show that the northern section of Station F is at high elevation of between 36-39m, whereas the southern portions are at an elevation between 27-30m and contain an abandoned outlet, A2. To the NE of Station F is a large and extensive drainage network, D1, with a tributary that is oriented NNE-SSW. LiDAR data also shows that this main tributary is aligned with abandoned channel A1 near Station D, but makes a sharp NW turn at Station F where it then meets with the Waikato River (Fig. 4.6C).

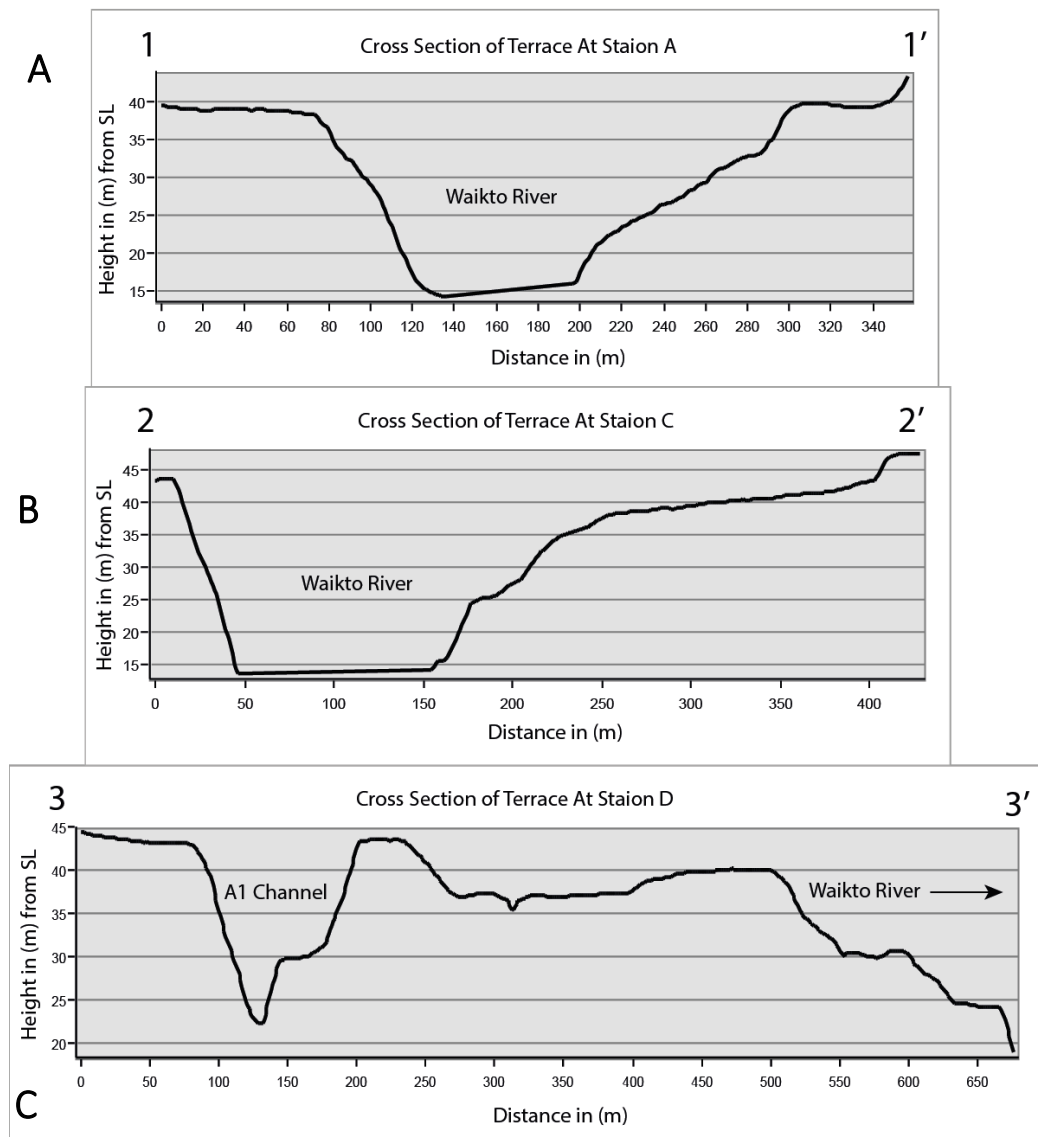

Figure 4.6. A) Cross section of terraces located at Station A. B) Cross section from east to west of the single terrace at Station C. C) Cross section across A1 channel from east to west. Note the three major terrace, to the west and a small fourth terrace near river level to the far east.

4.3.2 Field Results

Along the eastern bank at Station C recent river deposits were found along the lower portion of the terrace (Fig. 4.5B). Toward the east, as the bottom of the terrace begins to rise, Taupo Pumice Alluvium deposits are present. At the top of the terrace Hinuera Formation is present. The land above, where homes have been built, is also composed of older sediments, possibly Hinuera Formation, but evaluation close to the homes was not undertaken out of respect for the landowners' wishes. Hand augers taken to a maximum depth of 0.8 m along the terrace are marked as Bore Holes (1-8) (Fig. 4.7).

These boreholes confirmed the presence of the Hinuera Formation along the top of the

terrace (Fig 4.7). At the north section of this eastern terrace, at Location 2, was a thinly bedded yellow-white outcrop containing alternating silt with yellow-white clay layers present along the slope leading from the bottom terrace to the upper second terrace (Fig.4.7). These material characteristics are features of the Walton Subgroup and an attempt was made to follow the contact back toward the south to find its exact location. Unfortunately, due to the construction of an access road by the property owners the contact was lost under disturbed Hinuera Formation sediments that have been pushed over the slope during the construction. Similar outcrops were found near this area during boat surveys, and further down river ignimbrite was found at Locations 3, 6, 7, and 8. Samples from some of these outcrops during the boat survey were collected for thin section analysis of samples were taken. The thin sections showed an abundance of glass shards and ashy matrixes with some containing suspended pumices in an ashy matrix (Fig. 4.8; Table Appendix I). Few minerals were found in these samples, with only quartz and plagioclase being present. These characteristics indicate the samples were from primarily ignimbrite outcrops with some sections being locally reworked ignimbrite.

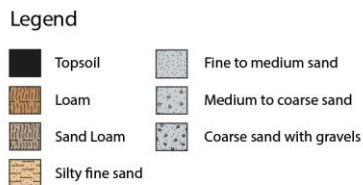
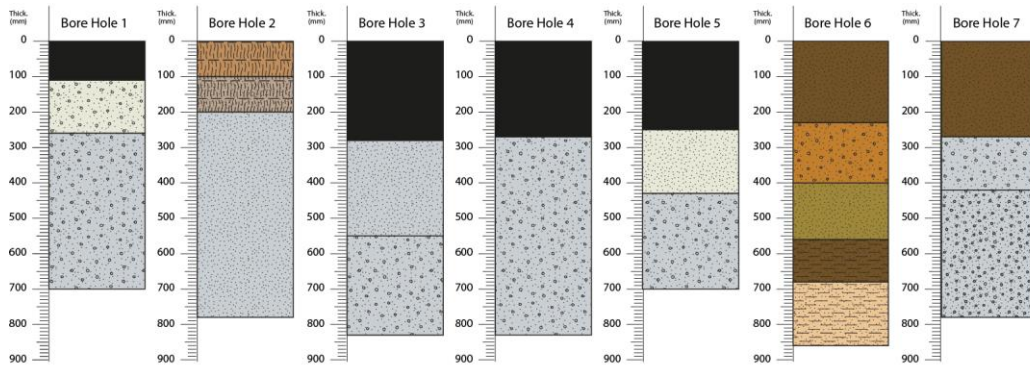
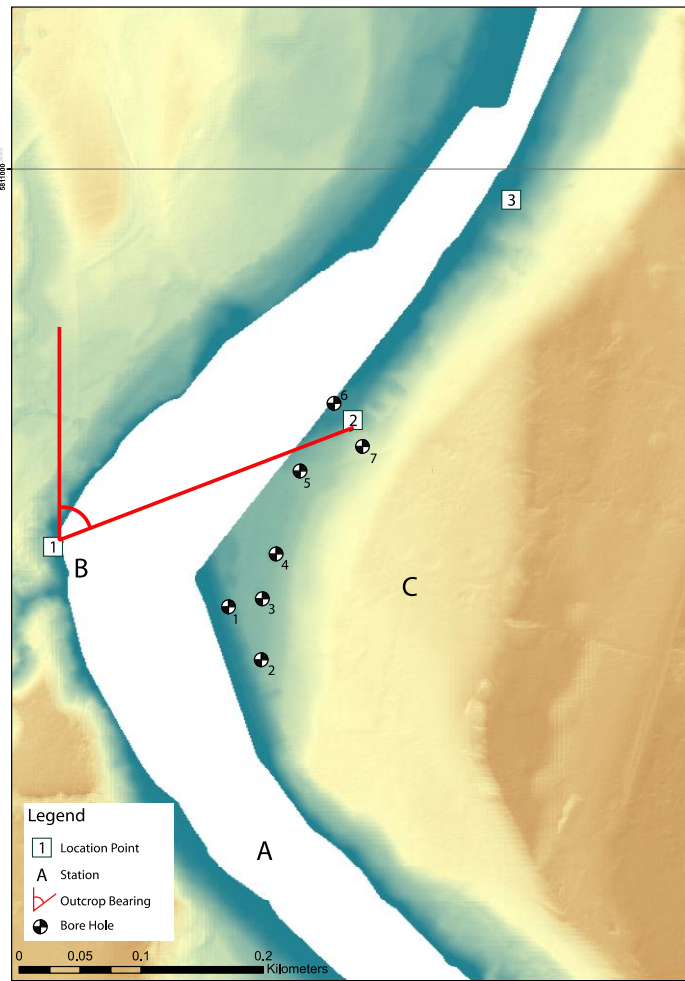

Figure 4.7. Map of showing the location of borehole transect taken at Station C along the lower terrace. Field locations are displayed by location numbers. The bearing between the two similar outcrops found at Location 1 to Location 2 across the river shown. Results from boreholes are presented in visual logs.

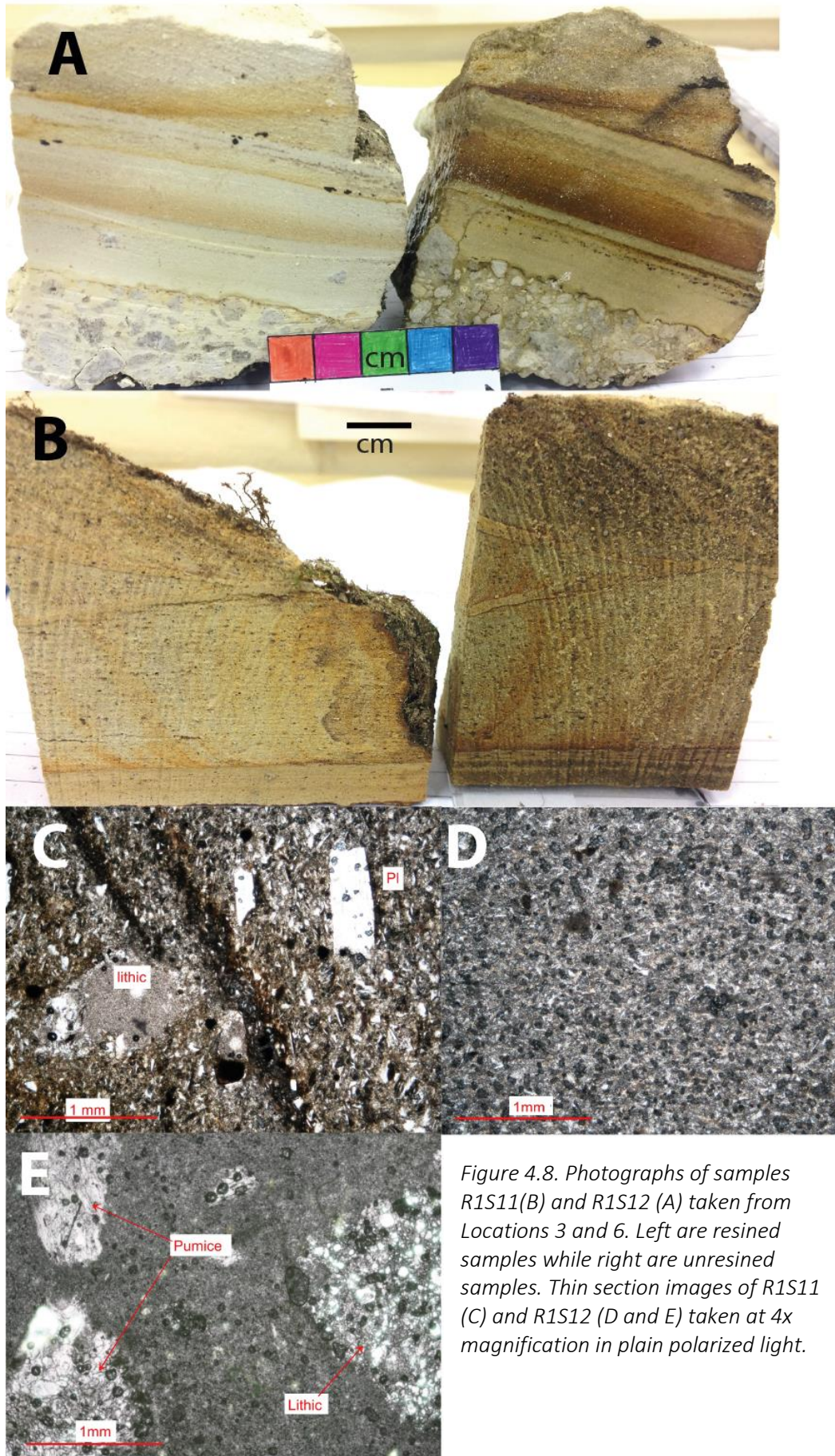

Figure 4.8. Photographs of samples R1S11(B) and R1S12 (A) taken from Locations 3 and 6. Left are resined samples while right are unresined samples. Thin section images of R1S11 (C) and R1S12 (D and E) taken at 4x magnification in plain polarized light.

The unit was followed down river to the peninsula shaped terrace at Station F where the deposits changed from ignimbrite to sedimentary deposits. Field investigations along the peninsula-shaped terrace showed Hinuera Formation along the higher elevations of the terrace outcrop and Taupo Pumice Alluvium deposits at the base near the river level. The contact between these two formations was unable to be located due to the heavy vegetation.

Along the western bank at Station D the western abandoned channel, A1, was composed of massive white cliffs with large pumice clasts and quartz and feldspar crystals. This unit was followed all throughout the drainage, but the best exposure of this unit is present along the northern section of the Stubbs Road region at Station E, Location 8, where a small beach landing and nature reserve is located (Fig. 4.9). The material makes up the steep cliffs along this region and thin sections collected throughout the drainage and the cliffs show massive, poorly sorted glass- and pumice-rich material indicative of an ignimbrite, particularly the Ongatiti. Mineral content consisted predominantly of plagioclase and quartz.



Figure 4.9. Photograph of Station E Location 8 of Ongatiti Ignimbrite cliff face.

At Location 4 a large exposed face along the SW side showed fine to coarse sands and gravels that are cross bedded, horizontally laminated, and graded, all classic signatures of the Hinuera Formation (Fig. 4.10A and C). I was unable to sample or evaluate the lower terraces due to farm works taking place at the time of the field evaluation and heavy

vegetation growth along the river during boat surveys. However, one exposed area at Location 5 did show sedimentary deposits were present along the western bank just past the sharp bend.

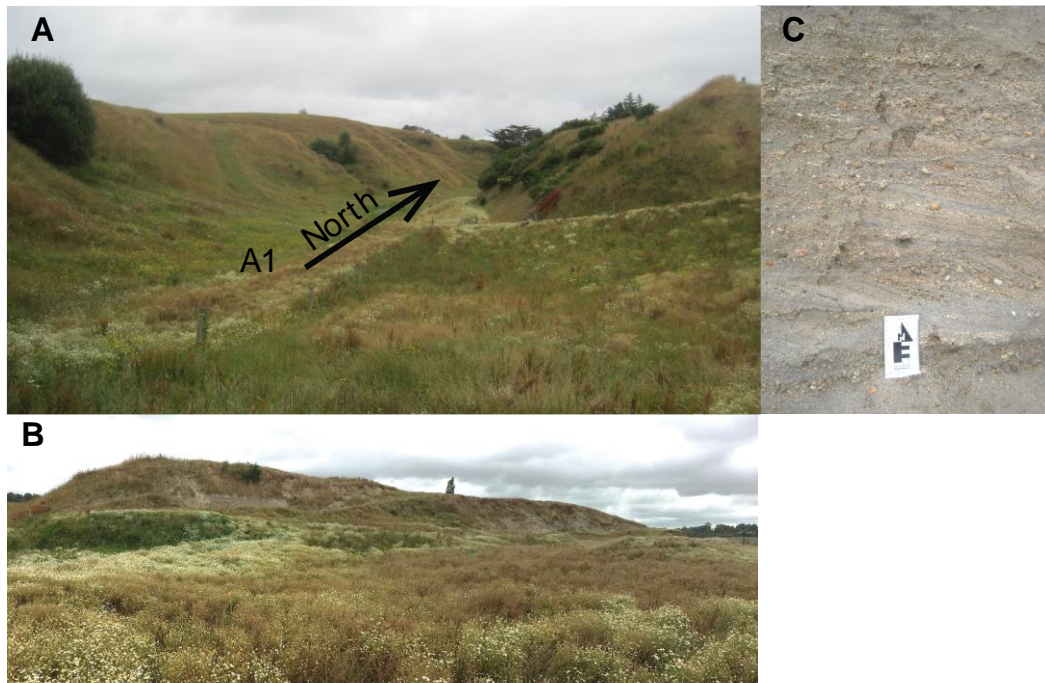

Figure 4.10. A) Photograph of A1 channel looking from the south to the north. B) Photograph of the tallest terrace at Station D, where Locations 4 and 5 were. C) Photo of Hinuera Formation cross bedded coarse sands and gravels from Location 4.

The field location that contained the most information was along the crest of the sharp river bend (Location 1; 37° 49' 38" S 175° 19' 34" E) on the western bank where a small fault was discovered (Fig. 4.11A). Near this location the larger N-S drainage begins and the small N-S gully drains into the Waikato River via a small waterfall. Outcrop at Location 1 displayed offset depositional beds (Fig. 4.11A photo). The outcrop consisted of alternating pale yellow to white clay layers with a band of medium pumiceous yellow sediments toward the top (Table 4.2, 4.8C). The other lower sections contained pumice clasts suspended in an ashy matrix indicating an ignimbrite deposit (Fig. 4.11D). The beds appeared to have a shallow plane of offset to the south which was marked by the ductilely deformed clay beds and a precipitated iron pan along the plane (Fig. 4.11A and B). Measurements were taken along the contact between the looser sediments, the clay, and the ironpan deposit. The plane is oriented with a dip of 85° with a dip direction of 047° with a measured apparent offset of 43mm. Measurements between this outcrop and the Walton Subgroup-ignimbrite outcrop across the river to the east shows a 66° angle from north between them (Fig 4.7A).

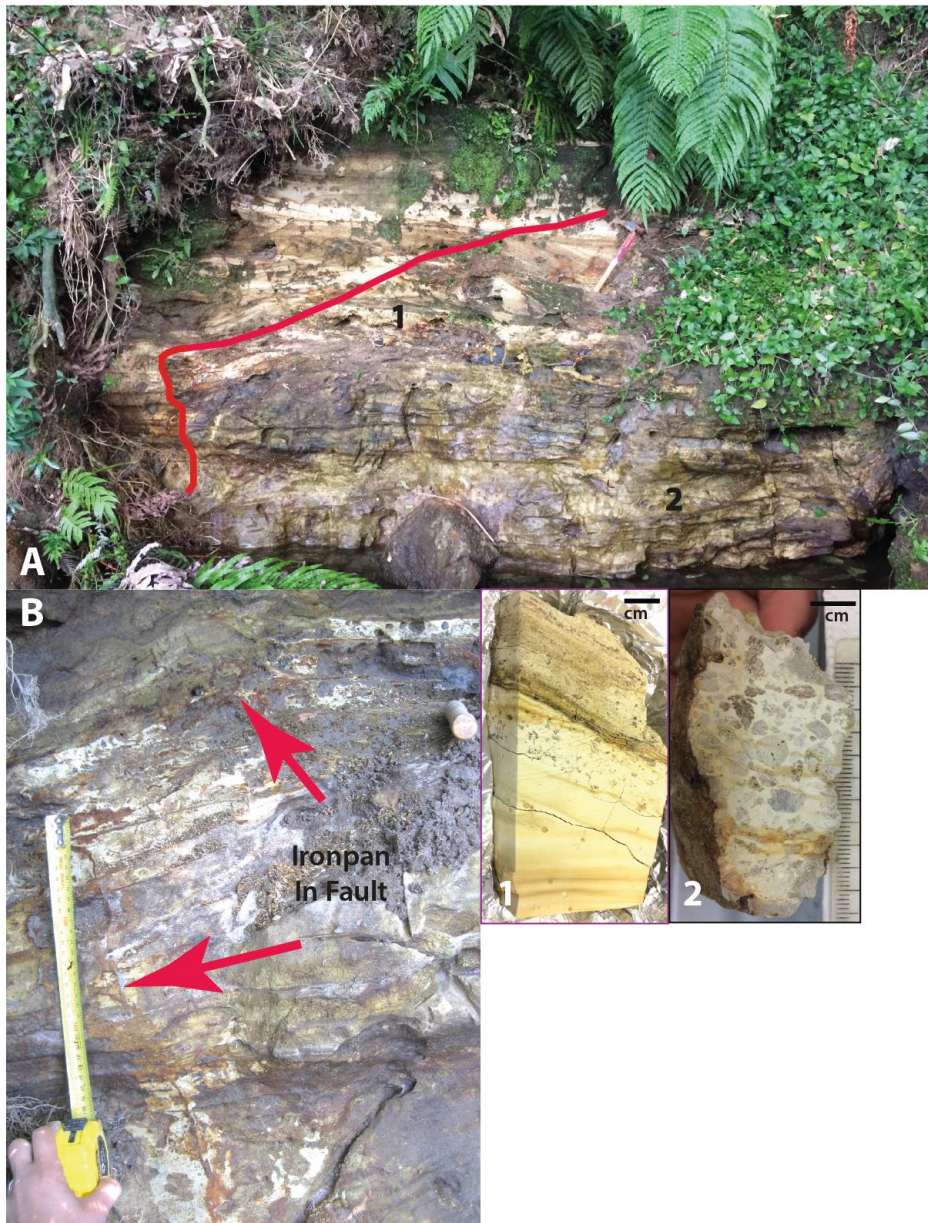

Figure 4.11. A) Photograph of fault outcrop at Location 1. The fault line is traced in red and cuts through the units toward the river. Samples taken from the outcrop are marked by numbers 1 and 2 on photograph. B) Close up of the lower section of the fault plane with ironpan precipitation, marked by red arrows, present within the fault line. Above offset beds can be observed. 1) Sample R1S8B_Lower consisting of ash section topped by glass shards, minerals, lithics and pumiceous material on top. 2) Sample R1S8D taken during second visit to the site. Consists of pumices and lithic pieces suspended in an ashy matrix.

4.3.3 Multibeam and Seismic data

Multibeam data shows a large ENE lineation near Station B with a bearing measuring 74° with a small NE oriented step with a bearing measuring 42° (Fig. 4.11A and B). A deep depression is present on the NW side of the lineation along the crest of the bend in the westerly corner. To the south of this depression is a distinctive lineation indicating a

stronger material to the south followed by a depression to the north (Fig. 4.11B). Seismic survey data shows a narrow depression occurring from south to north (Fig. 4.11C). On the southern section the data shows a dense material reflecting up to five areas. On the north only three dense areas are reflected. A lineation with slight offset is seen cutting through the top layer on the south portion and another offset is located on the northern section within the top portion the material (Fig 4.11C). No offset is present within the depression from this survey, but there is a difference in densities from the south to the north, indicating a possible change in the lithology or a difference of induration.

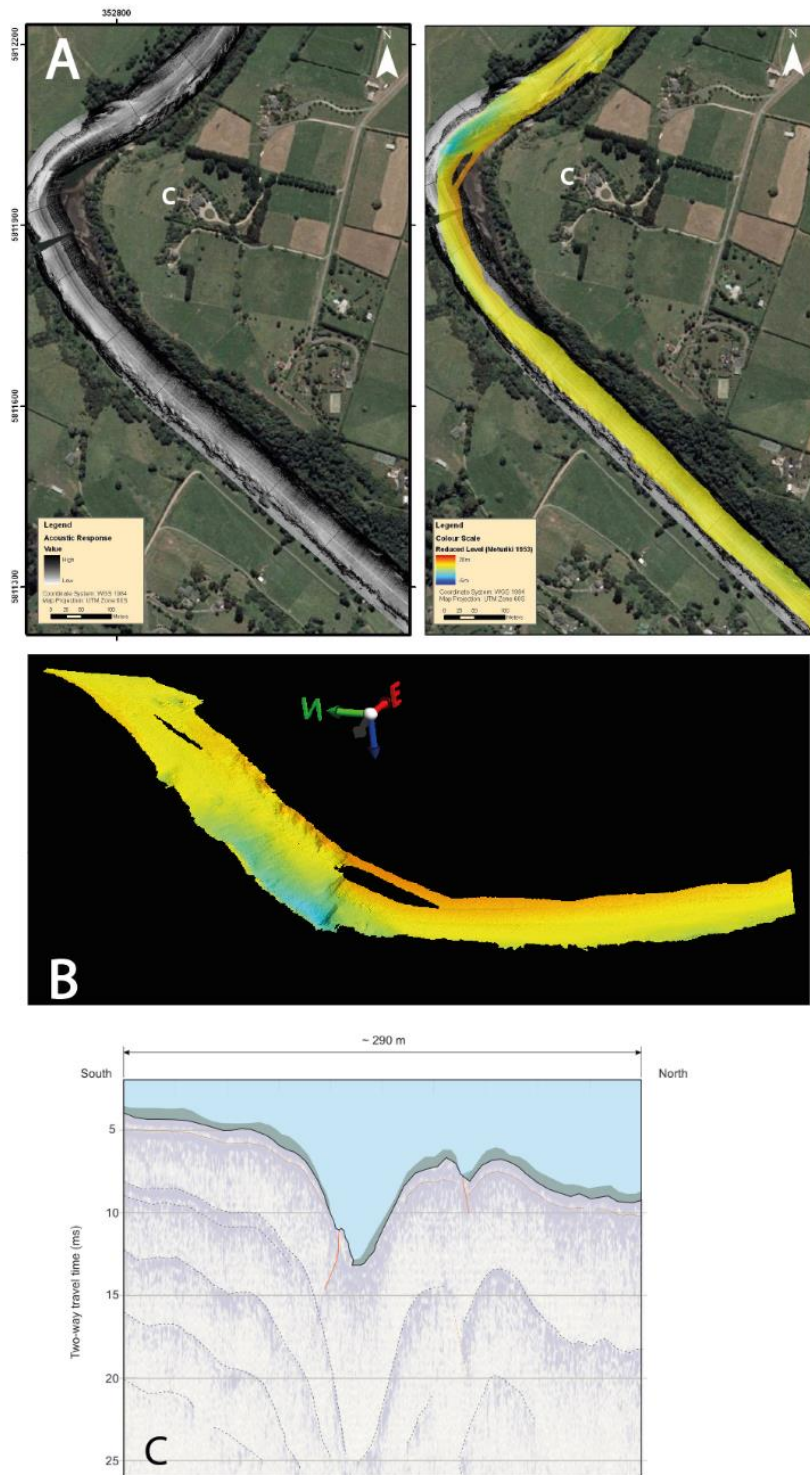

Figure 4.12. A) Sidescan Sonar and multibeam imaging taken during Wood's (2006) investigation of the Waikato River's geomorphology. Note the orientation of the depression seen in the multibeam image on the right. B) 3D multibeam image of the depression constructed by Wood (2006). Note the NE lineation along with a secondary step oriented N. C) Seismic survey results taken across along the bend and across the depression. Denser material is present to the south as seen by more reflected multiple material, whereas the north has fewer.

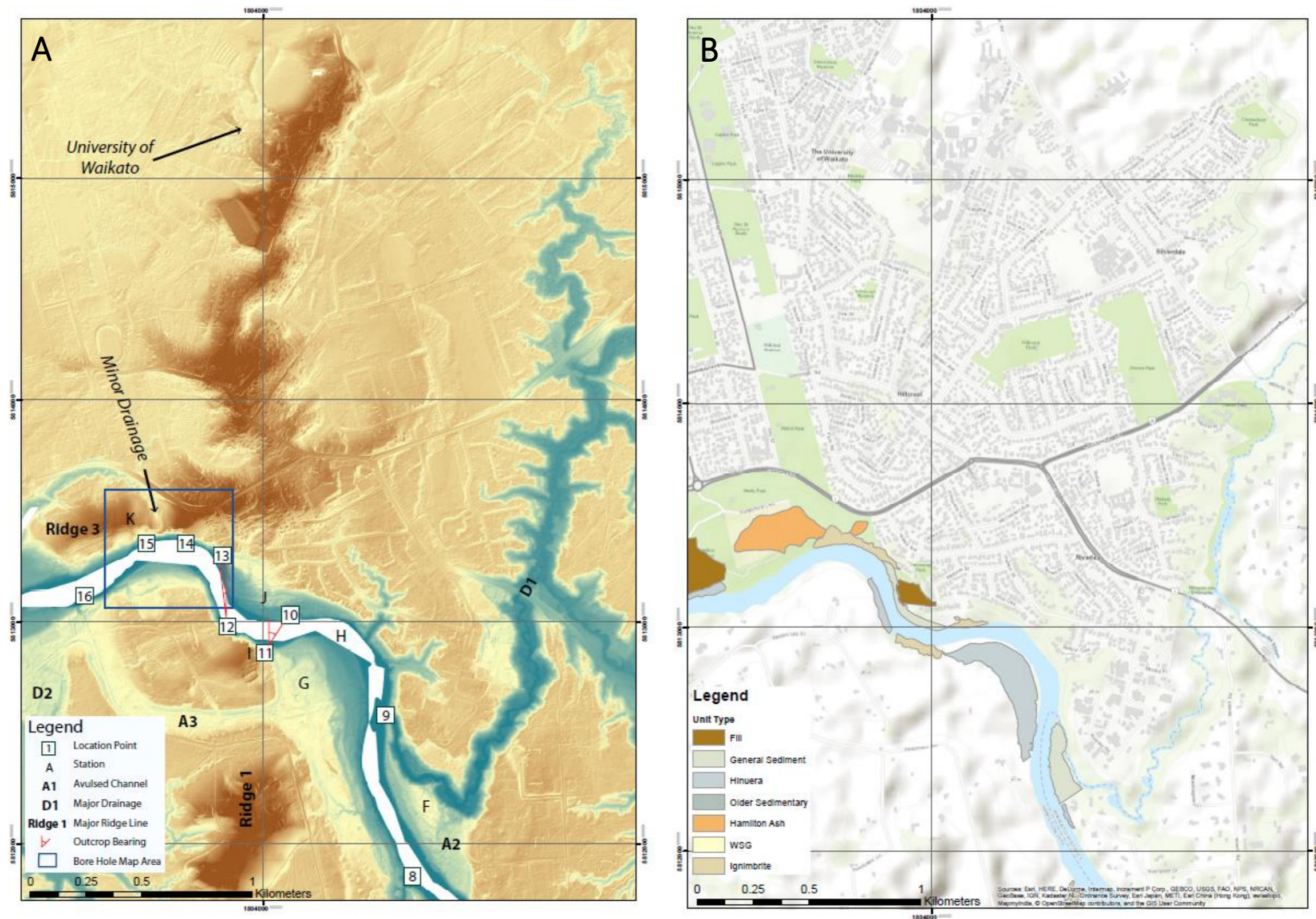

Figure 4.13. A) Geomorphic map of Hammond Park. Major geomorphic features such as ridges, major drainage systems, avulsed/abandoned channels are shown. Important areas of interests in the field and from remote sensing examinations are marked by station numbers. Locations with importance to field outcrops are marked by location numbers. Locations of additional investigations conducted through LiDAR cross sections and bore hole transections are presented on this map with specific results from these studies presented later on in this section. Bearings between outcrops found at Location 10 to 11 and 12 to 13 are marked on this map. B) Geological Units map of Hammond Park with all potential lithologies along the Waikato River presented in the Legend and mapped lithologies found in the field shown on the map

4.4 Hammond Park

4.4.1 Geomorphology

In this section the area of focus extends from south Hammond Park at Riverglade Drive to the Cemetery in the Hamilton Gardens (Fig. 4.1). Located in this area is a series of bends measuring approximately 100° and 94° that form an eastward rotated “M”. A large NNE-SSW oriented ridge, Ridge 1, cuts through the middle of these bends (Fig. 4.1). The ridge line begins in the SSW along the western side of the Waikato River near Ohaupo and extends north to where it crosses the Waikato River. From here the ridge extends in a NNE orientation towards the University of Waikato. East of the ridge, and the Waikato River, there is a large drainage that parallels the ridge line. This drainage was introduced in Section 4.3.1 with attention given to its outlet and its beheading of a set of large NW oriented drainages (Fig. 4.1). Note that the section of the tributary that beheads these other drainages is the only segment oriented parallel to the ridge line (Fig. 4.1). Along the western bank of the Waikato River and the west side of the large linear ridge is a set of smaller semi-parallel ridges separated by linear drainages (fig. 4.1). These ridges and their associated drainages will be discussed further in Section 4.6.

From the Stubbs Road study area the Waikato River continues with a northerly orientation. As the river begins to approach the ridge line it bends orthogonally to the west beginning at Station H, then again to the north near the crest of the ridge line at station I, and orthogonally again back to the west, near station K, where it maintains its orientation as it continues on past the Hamilton Gardens (Fig. 4.13A). Wide terracing on both sides of the Waikato River can be observed along station F as the river approaches the first bend near Station H; this then changes to a one sided terraces located at Station J until it reaches the western side of the large ridge line. LiDAR images show that the Waikato River becomes constricted beginning just south of Malcolm Street near Stations J and I where the river meets Ridge 1. The constricted section ends just past the west side of the cemetery at station H (Fig. 4.13A). The terraces along the eastern area marked by Station I and J appear to form a choking point similar to those seen at Stubbs Road.

Near the first bend at station G there is a large, wide terraced section. LiDAR data shows a large abandoned river channel, A3, which begins on this terrace and ends on the other side of the ridge line near Location 16 (Fig. 4.13A). A3's inlet is narrow, measuring about 90-100m wide, and occurs in line with the western side of the ridge. The channel maintains a westward orientation until it reaches the other side of the ridge line where it makes a sharp

rectangular bend to the north, similar to others observed along the Waikato River and in Hammond Park. At its outlet at Location 16, A3 measures 120-130m wide and is flanked by terraces on either side (Fig 4.13A). Just downriver is another set of N-S oriented drainages running along the eastward side of the ridge line that feeds into a large aggradational area along the Hamilton Gardens west of Station K. This aggradational area is complex and will be discussed further in Section 4.6. Along the northern bank of the Waikato River at Station K is a secondary W-E oriented linear ridge line, labelled Ridge 3, which extends from the western edge of the cemetery and ends near Beech Crescent. Separating the Ridge 3 from Ridge 1 is a N-S oriented drainage measuring 340° from north (Fig. 4.13A).

4.4.2 Field Results

The large terrace at Station G near the first bend is composed of Hinuera Formation sediments (Fig 4.13B). The Hinuera Formation was followed west toward the ridge to Location 11. At the base of the ridge line the Hinuera Formation disappeared and an outcrop composed of an amalgamation of material was present. The outcrop was highly weathered and contained sections of fine to coarse sand, gravels, and pumice clasts mixed with large randomized ripped up silt clasts ranging in width from 130mm to 500mm across (Fig. 4.14A). These materials appeared to be layered and graded in some sections, but also appeared random and almost massive in others (Fig. 4.15), indicating a landslide debris deposit.

Five metres west and slightly uphill an outcrop of yellow pumice lenses mixed with layers of white reworked ashes was present (Fig. 4.14C). Thin section samples taken from both the pumice lenses and the reworked ash indicated the deposit to be a slightly reworked ignimbrite, due to the presence of intact glass shards, fresh streaky pumices, and lithic pieces with angular minerals in the samples (Appendix I). Attempting to follow this outcrop further up the ridge was difficult due to erosional debris and heavy vegetation, but two more outcrops were found near the top. The first outcrop on the ridge was composed of yellow, pumiceous, fine to coarse gravels deposited in thin beds, and the second outcrop was a large ignimbrite showing three eruption events separated by sharp wavy contacts (Fig. 4.14B and D). The ignimbrite was massive, white, non-welded, and rich in pumice, but it was not distinct enough to tell what specific ignimbrite formation was there (Fig. 4.14D). Outcrops of ignimbrite were found during boat surveys along the cliffs along the ridge line at Location 12 and appeared to have a dip between 20-30° to the south. Slightly down river from Location 12 were outcrops of Hinuera Formation. Back tracking upriver to investigate this change led to the discovery of another outcrop, marked as Location 12, which

appeared to have offset beds (Fig. 4.16A). However, the bed was high up on the near vertical cliff face with grasses covering sections, making it hard to determine and measure. The location of this outcrop was marked as an inferred fault due to the change in outcrops observed and the offset beds, but confirmation cannot be given unless the outcrop reveals better exposure. It is clear that a transition and change of lithologies from east to west occurs from Station G to south of Station K at the other side of the Ridge 1, but erosion, steep slopes, and heavy vegetation has covered any possible location where exact contacts between units could exist.



Figure 4.14. Outcrops found at Location 11 with 10cm arrow for scale. Stratigraphic log of outcrops A and B are below in Fig. 4.15. A) R2S2.1 outcrop from the lower section of Location 11 where the terrace meets the ridge. Note the large ripped up silt clast where the scale arrow is located. Additional small ripped clast can be seen near the bottom left of outcrop. B) R2S2.2 second outcrop taken close to S2.1. Note the sharp contact and lens of iron stained pumice. C) R2S2.3 outcrop of thin layer of pumiceous coarse sands found up on the ridge line. D) R2S2.4 Ignimbrite outcrop at top of ridge. A contact can be seen below the arrow marked by the change in colour. The contact indicates that the outcrop consists of potentially two ignimbrites formed during different eruption events.

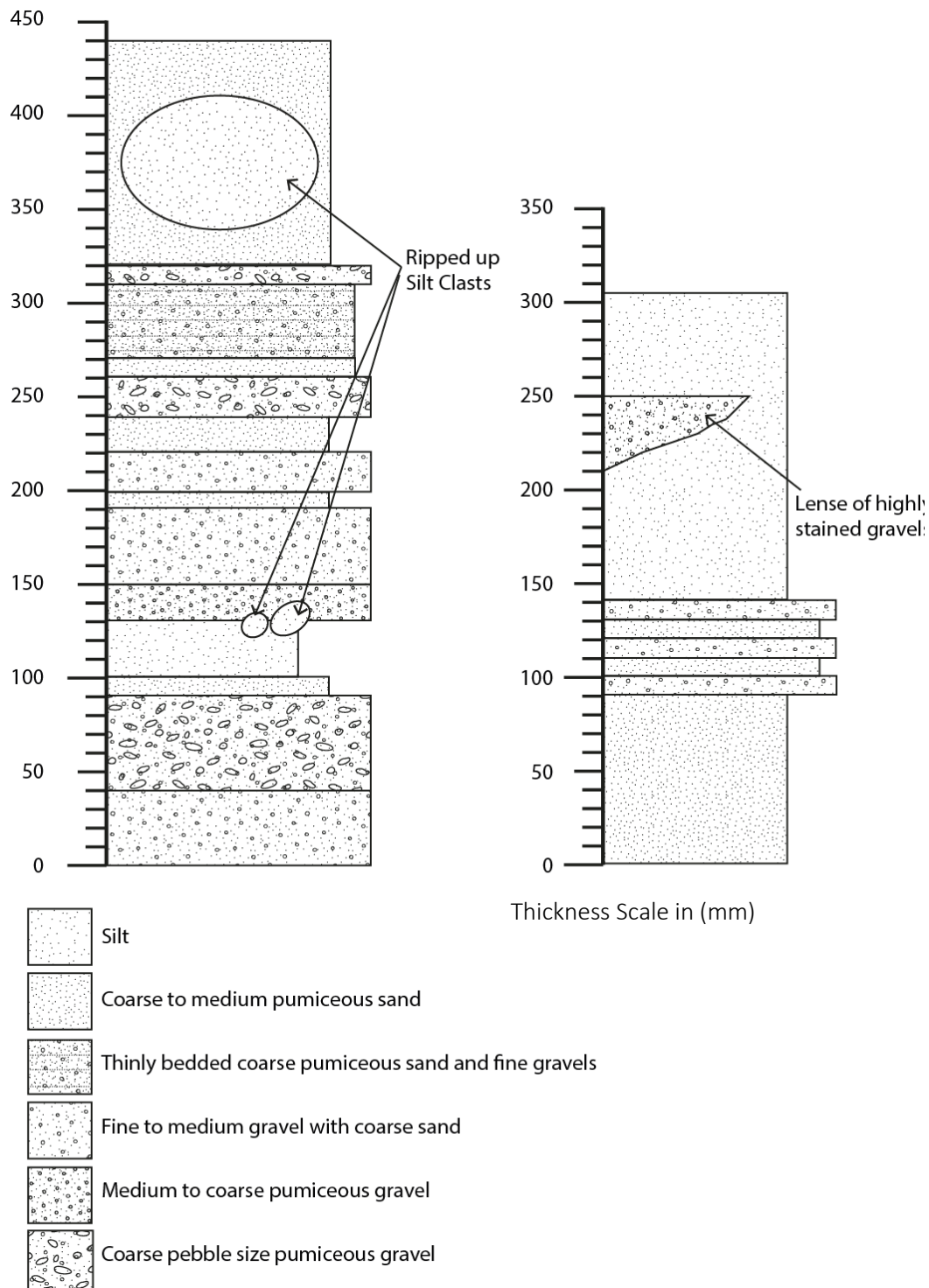

Figure 4.15. Stratigraphic log of R2S2.1 and R2S2.2 as seen in photographs A (on Right) and B (on left) in Figure 4.14. Details regarding colour not addressed given photos are provided. Note the alternating layers of the R2S2.1 and how all material found at this site have a pumiceous component to their structure.

Across the river at Station J along the single sided terrace, recent river sediments and Hinuera Formation were found, but while walking eastward toward Location 10 the topography rose suddenly and the geology present became a highly pumiceous ignimbrite

(Fig. 4.12A and B). The ignimbrite was followed up river just south of the nature reserve entrance in south Hammond Park where the river then covered the exposures. It is important to note that the ignimbrite was present at the river level between Station H and J, whereas slightly down river at Station J sediments were found instead. Outcrops found between Stations H and K via boat survey were limited due to heavy vegetation growth along the bank with only few accessible exposures near at Locations 12, 14, and 15. The bearing between the ignimbrite outcrops found at Location 11 on the west bank to the ones at Location 10 on the eastern bank was measured to be 33° (Fig. 4.12A). Down river along the bank at Station J Hinuera Formation and fill are found through many sections of Hammond Park. However, at the far northern corner at Location 14 where the terrace stops at the ridge line, and tucked in behind lots of overgrowth and trees were several small outcrops of alternating layers of yellow pumice clasts and white clays, indicating locally reworked ignimbrite (Fig. 4.16C). As mentioned previously, across the river, along the western bank near Station I, boat surveys found a change from ignimbrite deposits to sedimentary deposits along the cliffs with one outcrop marked by Location 12 possibly containing offset bedding, inferring the presence of a fault (Fig. 14.16A and C). The offset between the ignimbrite from along the cliffs on the western bank at Location 12 to the outcrop of the locally reworked ignimbrite on the northern bank at Location 13 was 7° (Fig. 4.12A).

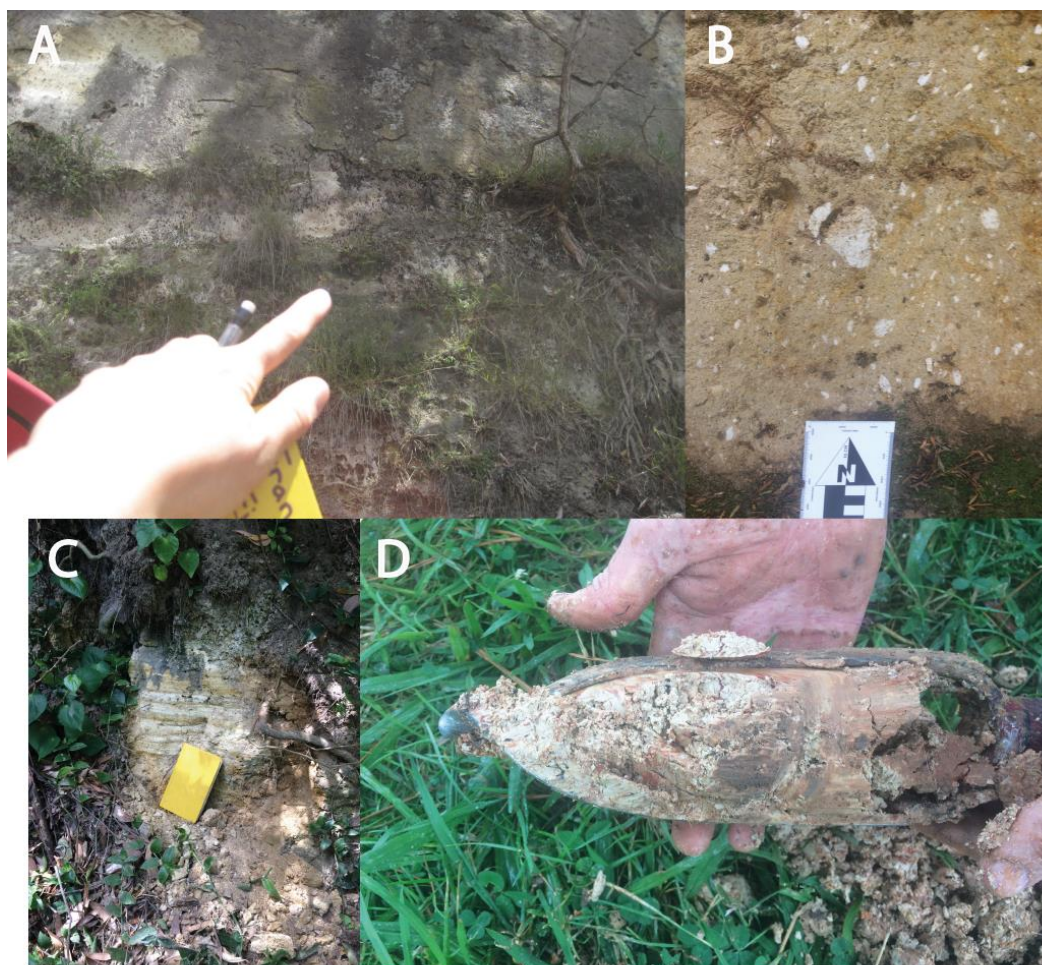

Figure 4.16. A) Photograph of outcrop at Location 12 with finger indicating the offset bed. Also note how far up this bed occurs, making it difficult to access. B) Ignimbrite outcrop at Location 10. C) Locally reworked ignimbrite outcrop found at Location 13. Field notebook for scale. D) Photo of borehole 4 of the white clay rich material in contact with Hamilton Ash above.

Along the E-W ridge at Station H 2.0-3.0m hand augers were taken from the west to east of the drainage for cross section analysis (Fig. 4.17). A drainage oriented at 340° is present, separating the smaller western ridge, Ridge 3, from the main NNE-SSW ridge line, Ridge 1. It must be noted that due to poor weather, swelling of the clay, and hole collapses some of these holes are limited in depth and they do not terminate at the same level. Many of the holes revealed clay rich materials varying in many shades of brown, indicative of the Hamilton Ashes. Boreholes 1-3 and 6-8 contained only this layer aside from topsoil, and showed it extended between 780mm to 2800mm (Fig. 4.18 and Table of description). Holes 4 and 5 showed only a small layer of this clay from 65mm to 890mm, but below was a purple, micaceous layer and/or white clays and silts with strong concentrations of pumice, indicating Rangitawa tephra and ignimbrite. Hole 4 measured up to a depth of 2090mm of

the ignimbrite material before the hole collapsed, similar to the depth of hole 3 which showed 2800 of Hamilton Ash (Fig.4.18).

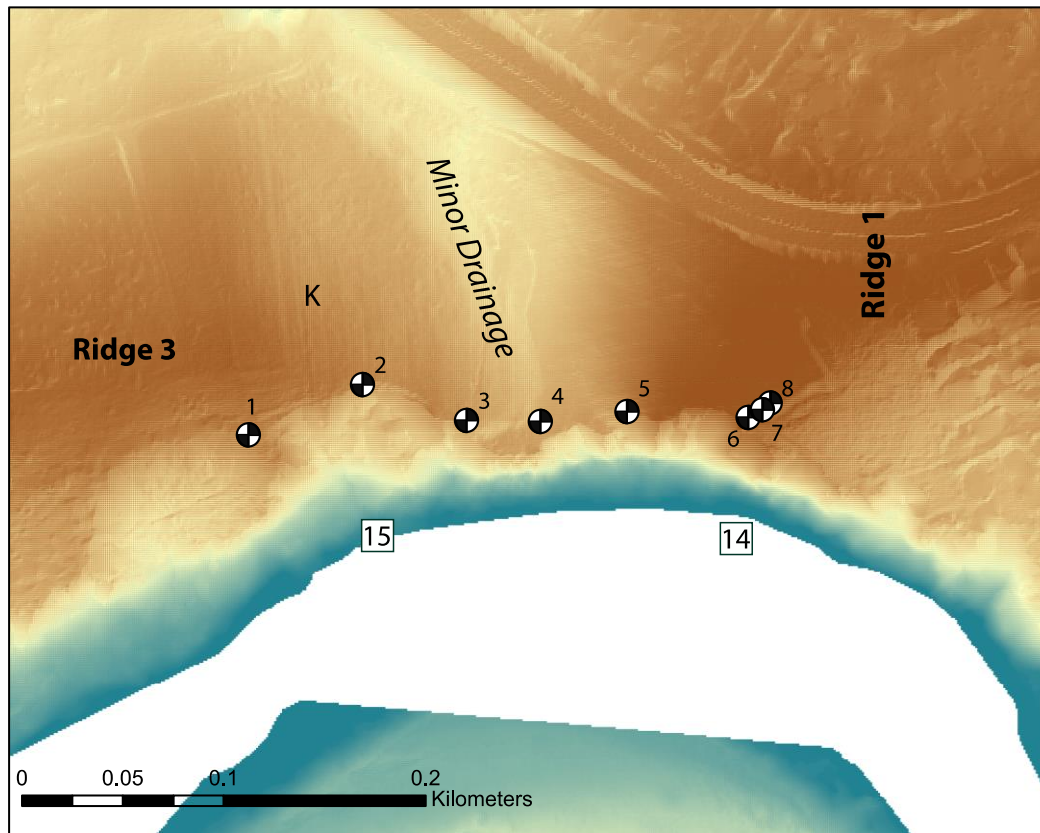

Figure 4.17. Map of bore hole transect taken at Station K between Ridges 1 and 3. Bore holes 6 to 8 taken across a small hill with dip in middle that had similar orientation to the minor Drainage. Cross section was taken from hole to hole along the ridge line on ArcGIS to get elevation due to issues with the GPS. Results of cross section and borehole data are given below in Figure 4.18. Location of ignimbrite outcrops found during boat survey are marked by Location 14 and 15.

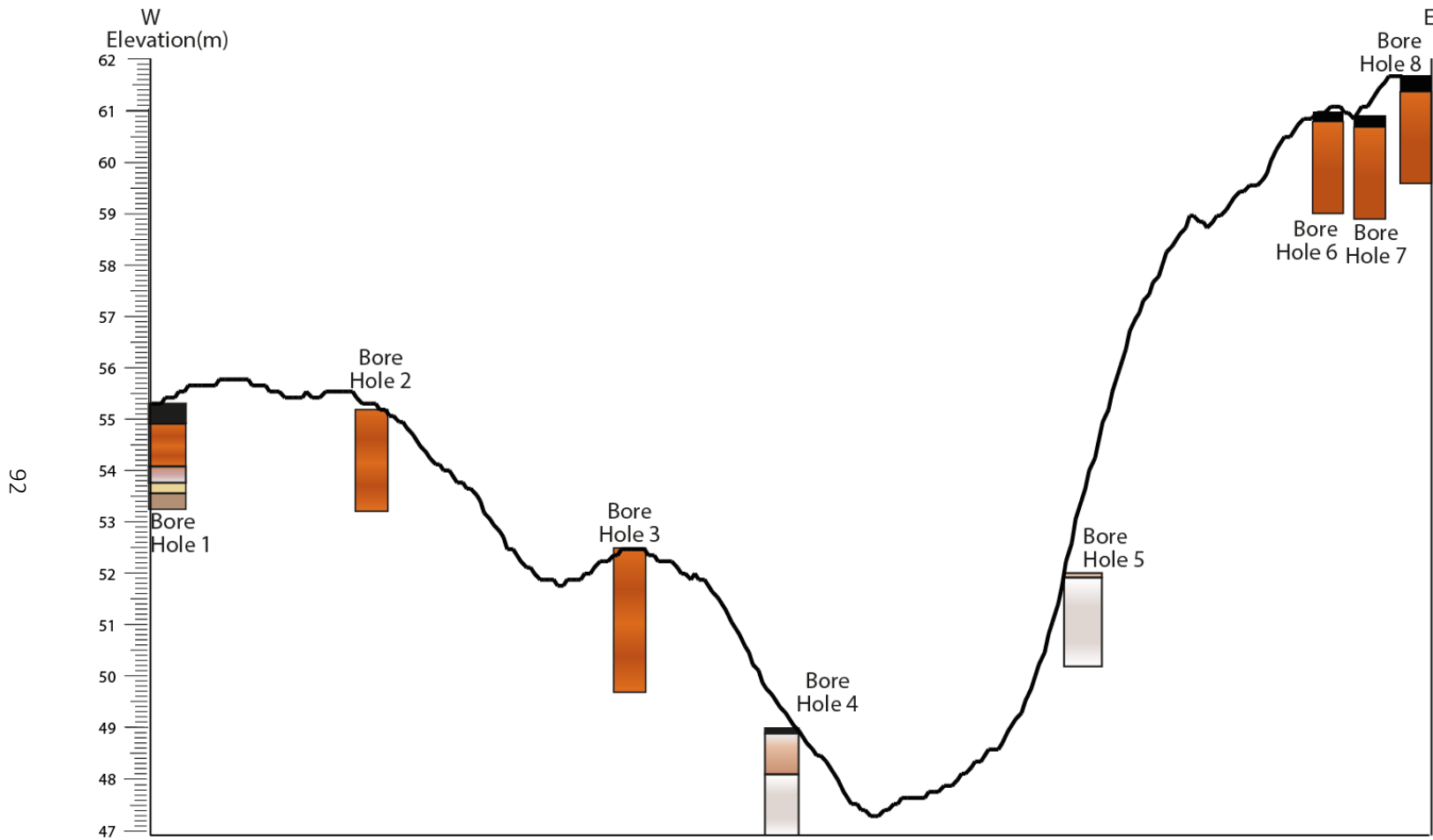

Figure 4.18. Cross section of bore holes taken at Station K. Note the change of ignimbrite out crops at holes 4 and 5, with 5 having similar elevation to hole borehole 3. Dip in ridge line can be seen near boreholes 6-8 but results did not show difference in material.

4.4.3 Multibeam and Seismic Data

Multibeam images show two areas with strong lineations cutting across the river bed (Fig. 4.19). The first is located at the first bend. The line at this location is oriented SW-NE, with a deep depression located along the northern and western side of the lineation. The deepest section of this depression occurs along the northern section of the Waikato River bank and just west of the first bend's crest. On the east and southeast section material that is either different or more indurated is present. The bearing of this lineation cutting across the river bed was measured to be 031° (Fig. 4.19).



Figure 4.19. A) Multibeam image taken by Wood (2006) with location of 3D images marked by numbers 1 and 2. 1) 3D multibeam image with a depression on the western side and a strong linear feature cutting across the bottom of the riverbed. This lineation is also stretches between Location 12 and 13. 2) 3D multibeam image with a depression on the northern side and a strong linear feature cutting around and across the riverbed near Bend 3. This lineation also stretches between Location 10 and 11

Just past the middle of the two bends is a lineation oriented NNW-SSE and measuring at a bearing of 003° (Fig. 4.19). On the eastern section either a different lithology or more indurated material is present, whereas a depression indicating weaker or different material is located along the western side of the lineation. These structures are similar to the ones observed in the multibeam data of Stubbs Road.

Along the first bend at station H, seismic surveying shows a narrow knickpoint present with offset bedding located within the depression (Fig. 4.20C and D). At the beginning of the second bend the survey showed more complex formations with up to seven locations with offset bedding (Fig. 4.20A and B). There is no single knickpoint at this location, but a sharp change in gradient does occur from south to north indicating that there is one present, just not as well formed.

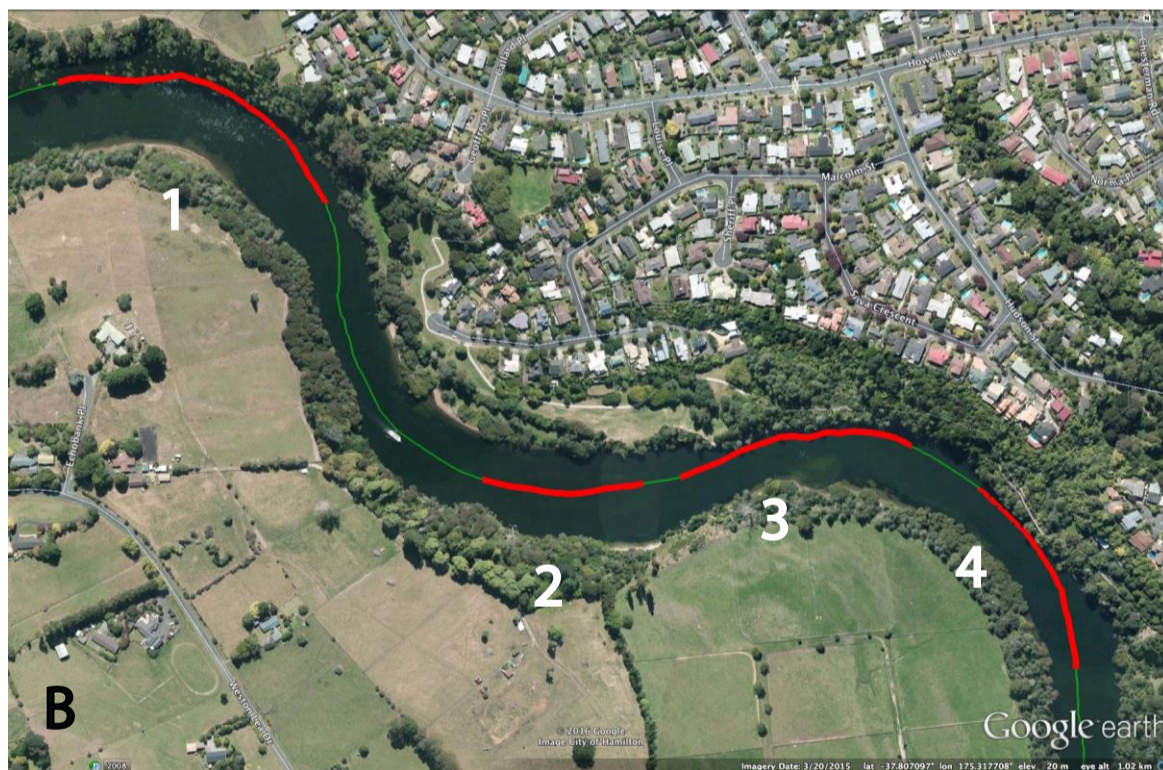
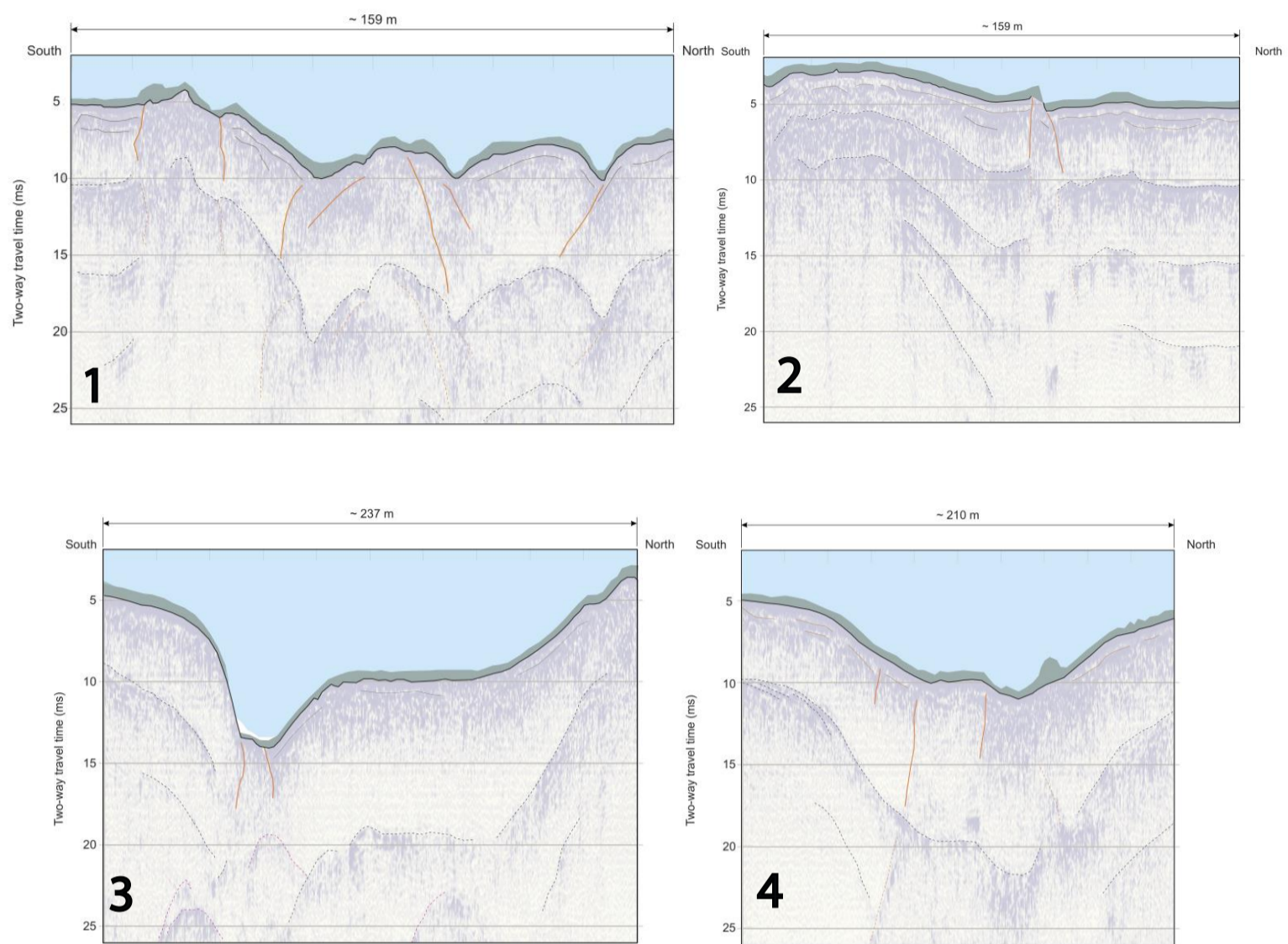

Figure 4.20. Seismic Survey data taken along Bends 3 and 4 at Hammond Park. Location of each specific survey image is marked by number 1-4 in the map below. Image 3 was taken along the transect of the scourhole seen in the 3D multibeam image in 4.19-2 and shows knickpoint with discontinuity. No transect was taken along the region between Location 12 and 13, but images 1 and 2, taken up and down river of that region, show a discontinuity. Image 2 shows a change in the density of the riverbed geology from less dense in south and more dense in the north.

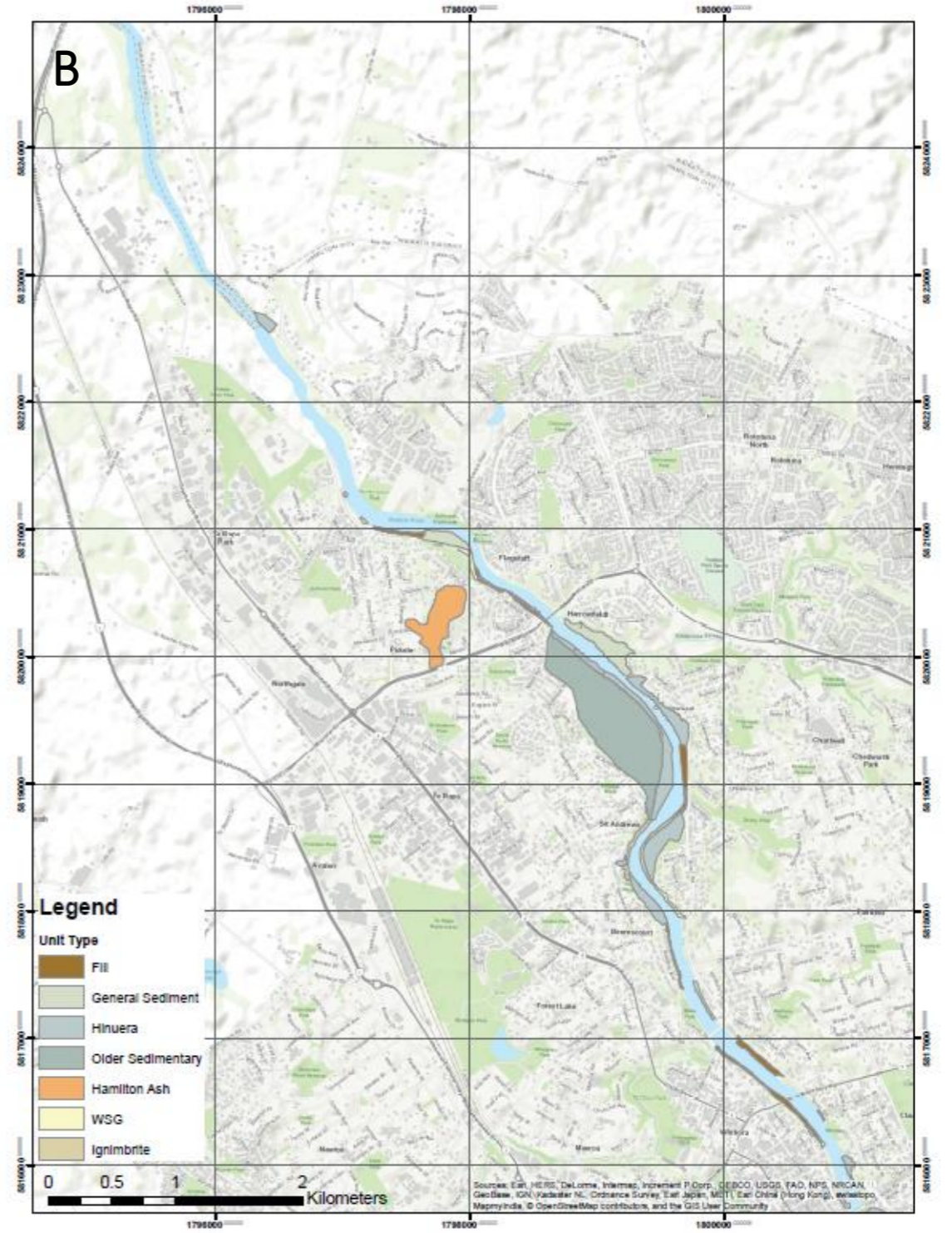
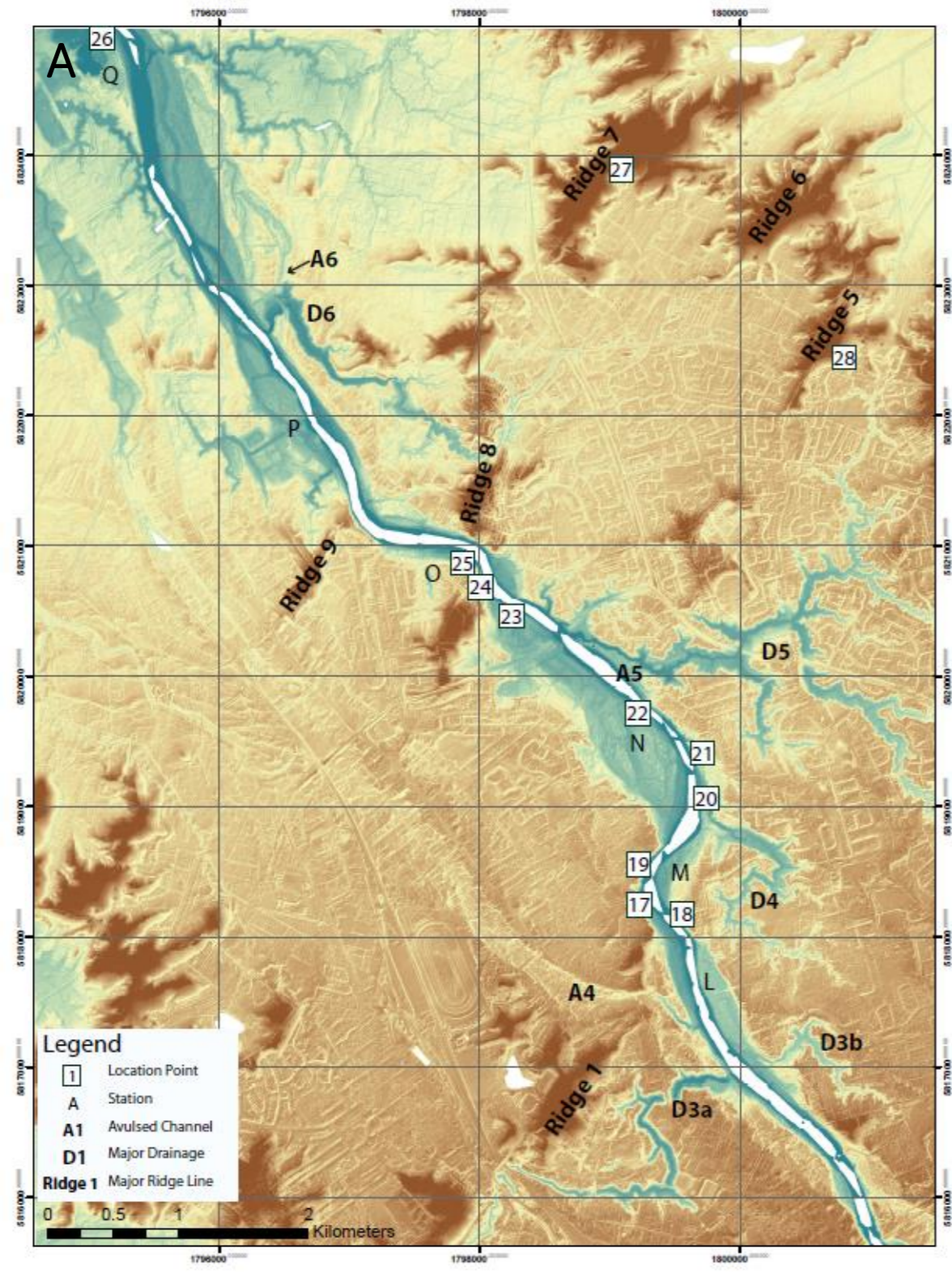

Figure 4.21. A) Geomorphic map of region from Day's Park to Horotiu. Major geomorphic features such as ridges, major drainage systems, avulsed/abandoned channels. Important areas of interests both in the field and from remote sensing examinations are marked by station number. Locations with importance to field outcrops are marked by location numbers. B) Geological Units map of Day's Park to Horotiu with all potential lithologies along the Waikato River presented in the Legend and mapped lithologies found in the field shown on the map.

4.5 Day's Park, Braithwaite Park, and Horotiu

4.5.1 Geomorphology

In this section the area of focus will include locations just south of Day's Park at Station L near Awatere Avenue and extend to the old Horotiu Bridge at Station Q (Fig. 4.1). The Waikato River within this field area has several similar geomorphic features to the ones at Stubbs Road and Hammond Park. The first is that as the Waikato River travels past central Hamilton it maintains a general NW orientation, then turns orthogonally near Station M to the NE, making an half-moon shape terrace along the eastern bank before it turns back again to the NW along Station N and continues (Fig. 4.1). At Station M, where River Bend 7 begins, a large NE-SW oriented ridge, Ridge 2, is present (Fig. 4.1 and 4.21A). The ridge begins in the west just past Whatawhata and curves around to the NE as it makes its way into the Hamilton Basin (Fig. 4.1). What is different about Ridge 2 when compared to Ridge 1 is that Ridge 2 does appear to continue along the eastern side of the Waikato River. However, to the east and north are several linear ridge lines, Ridges 4, 5, 6, 7 and 9, that possess similar orientations. Ridge 8 located just north of the Ridge 2, has an N-S orientation and crosses the Waikato River at Braithwaite Park at Station O (Fig. 4.21A). Interestingly, Ridge 8 appears to almost be an extensional arm between Ridges 2 and 7 (Fig. 4.1). Located at River Bend 10 is Ridge 7, a very small ridge near Braithwaite Park which parallels Ridge 2 on the western bank where the Waikato River returns to a NW orientation (Fig. 4.1).

At Station L, LiDAR data shows the Waikato River is flanked by alternating terraces with a height variation of approximately 5 m (Fig. 4.22). As the river approaches the southern area of Day's Park at Station M it becomes constricted, resulting in the beginning of River Bend 7 measuring approximately 98°. Following the bend is the formation of an entrenched segment accompanied with a single sided terrace at Station M (Fig. 4.21A). Near Station N the river turns back to its NW orientation and forms an exceptionally large floodplain in the structure of a single terrace. This large terrace is the land on which St Andrews Golf Course is located. At Station O, where Ridge 8 crosses the Waikato River, LiDAR data shows the river becoming constricted and turning about 115° to the west where it then entrenches until Station P (Fig. 4.21A). At Ridge 9 the river takes another sharp angular bend of approximately 110°, turning back again to the NW (Fig. 4.21A). Along Station P the Waikato River is flanked by wide terraces the rest of the way toward Horotiu at Station Q (Fig. 4.21A). Major drainage systems D3, D4, D5, and D6 are located with this field area (Fig. 4.1). Though each drainage system has its own specific characteristics, each possesses a

rectangular drainage pattern or sharp angular turns located prior to the drainage's outlet. D3 is a set of linear drainages, labelled as "a" and "b", located south of Station L and Ridge 2 (Fig. 4.21A). Along the western bank D3a has a general NE orientation and follows along south of the Ridge 2. The western side of D3a has bends between 100°-127° before it connects to the river. Across on the eastern side of the Waikato River, the small drainage of D3b has an outlet aligned with the outlet of the western one. This smaller drainage contains two rectangular turns measuring 80° and 117°, occurring along the same axis (Fig. 4.21A). D4 is a singular drainage system along the eastern bank of the Waikato River and makes up the grounds of Donny Park. D4 contains four major rectangular bends measuring between 87-124° (Fig 4.21A). What is interesting about these turns is they each occur in alignment with one another and Ridge 2 almost as if they were on a similar axis (Fig. 4.21A). Along the eastern bank across from Station N is a large drainage system D5. This system has a general NE-SE orientation with its tributary nestled between Ridges 3 and 4 (Fig. 4.1). However, the drainage system has several branches that are oriented NW and become captured, or beheaded, by the main NE oriented tributary. As the drainage makes its way toward the Waikato River it takes an angular bend of approximately 111°, abruptly changing its orientation from NE to the NW and leaving an abandoned outlet labelled A5 (Fig 4.21A). Along the eastern bank at Station P is another long drainage (D6) that has a NW orientation but also makes a rectangular turn of about 60° before it outputs into the Waikato River (Fig. 4.21A). North of this abrupt turn the LiDAR data shows a NW oriented abandoned channel (A6) connected to D6. At Station L is a NW oriented abandoned channel, labelled A4, which cross cuts Ridge 2. A4 has been deemed a paleochannel of the Waikato by McCraw (2011). The inlet of the channel is located on a wide western terrace at Station L, but becomes quickly choked as it passes through Ridge 2 with its inlet measuring a width of about 80-90m. At this choke point the paleochannel makes turn of approximately 140° and is oriented westward before it then turns back to the NW, a similar pattern to the Waikato River Station O (Fig. 4.21A). When the paleochannel passes Ridge 2 it widens to widths between 140-180m and traces of the channel slowly fade away into the topography as it continues NW (Fig. 4.21A).

4.5.2 Field Results

Considerable amounts of fill were found on both sides of the river from the Boundary Road Bridge north to the Station M, making it difficult to locate and follow geological units (Fig. 4.21B). Part of the reason the fill is present is because this region of the Waikato River has seen heavy urban development and changes close to the river in order to make way for

walking paths, homes, and businesses. There are some sections along the river where recent river sediments and Hinuera Formation are present, but care had to be taken to watch out for areas where the sand was placed during alterations to the ground rather than by the Waikato River. Along the western side fill continues until Anne St Park at Station L (Fig. 4.21B). Here a terrace composed of Hinuera Formation is present until Minchin Crescent, where Ridge 2 meets the Waikato River. At Location 17 the elevation dramatically increases and continues as a high elevation until the south tip of the St Andrews Golf Course, at Station N (Fig. 4.21B). At the base of this cliff near the river level reworked ignimbrite deposits consisting of a high concentration of lapilli to bomb sized pumices with little to no minerals were present (Fig. 4.22). Thin section evaluations from samples taken in this area showed large amounts of glass that have been slightly weathered and are graded with small layers of rounded, small (0.3 to 9mm) wide pumices (Fig. 4.22).

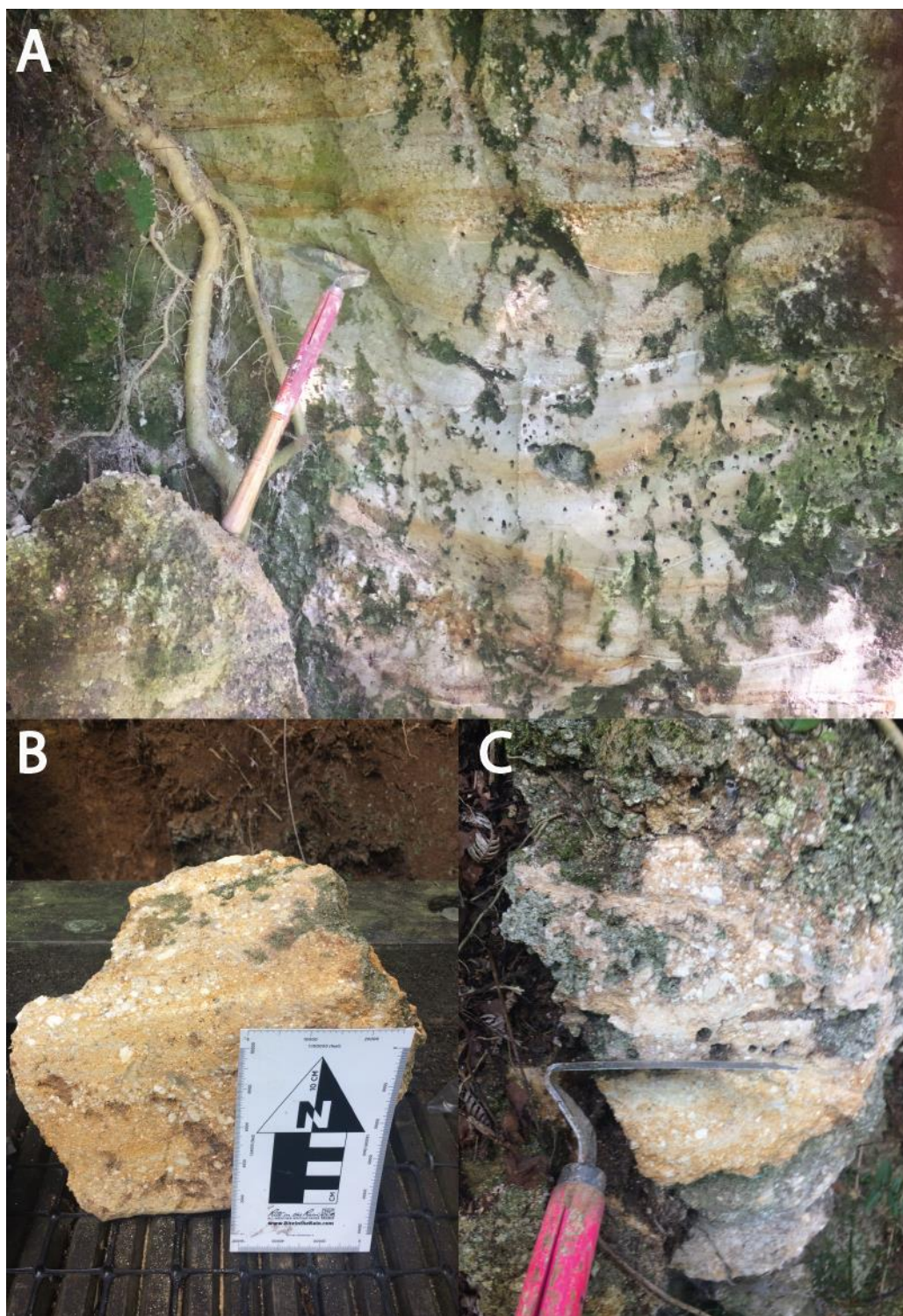

Figure 4.22. Photograph of Samples and outcrops found along Location 17 to 19. A) Outcrop found at base of hill at Location 17 near the river level. B) Photo of cleaned outcrop piece taken along foot path between location 17 and 19 that was taken for samples. C) Outcrop near Location 19 scraped along ridge line when it came close to the foot path.

Along the footpath large outcrops of heavily weathered volcaniclastic material indicative of Walton Subgroup were present, except for Location 19 where Hinuera Formation was present and had been reworked for home development (Fig. 4.21B). At Location 19 boat

surveys revealed that the Walton Subgroup was present at river level as well with outcrops composed of multiple small, grey, normal graded layers of reworked volcanic material consisting mostly of clays and weathered ash (Fig. 23). Though this material is graded and grey in colour similar to the Hinuera Formation, the bedding found at this location was consistently thin, and it is known that sections of the Puketoka Formation have been described as thin bedded normal graded grey reworked volcanoclastic deposit in sections (Kear and Schofield, 1978).

Along the eastern bank between Station L and M was a large steep white cliff containing up to five layers of reworked volcanic material (Fig.4.24). The cliff outcrop included a large 200-300mm thick coarse pumiceous lapilli layer, a 3.0m thick fine to medium lapilli layer, and massive silt/clay deposits deposited as layers and in some locations as lenses. This material is related to the Walton Subgroup, possibly the Karapiro Formation (Fig.4.25). The bearing of the line joining the outcrops on the west bank at Location 18 to the east bank at Location 17 was measured as 104°. Along Station M and extending up the river path toward Swarbricks Landing across from Station N, recent river sediments and sediments belonging to the Hinuera Formation were present (Fig. 4.21B). Between Day's Park to Swarbricks Landing large amounts of fill and sediments were found, probably placed during road construction. At Swarbricks Landing Hinuera Formation was present again (Fig 4.21B). Good exposures revealing these materials were found from a landslide that occurred north of Swarbricks Landing and from construction along River Road, both marked with Location 21 (Fig4.26A). Exposures along the eastern bank north of Location 21 became limited due to urbanization, heavy vegetation growth, and limited access. At Location 20 is an old pier where the geology makes a steep descent into the water (Fig. 4.26B). However I was unable to collect samples due to the rising water level and the material being heavily saturated. Across the river, along Station N where the St Andrews golf course is located, sedimentary based deposits are present but outcrops with the best exposure were found mostly along the beach. These outcrops comprise of coarse sands and gravels, but are highly ironstained and cemented making it difficult to tell if they belong to the Taupo Pumice Alluvium or Hinuera Formation.

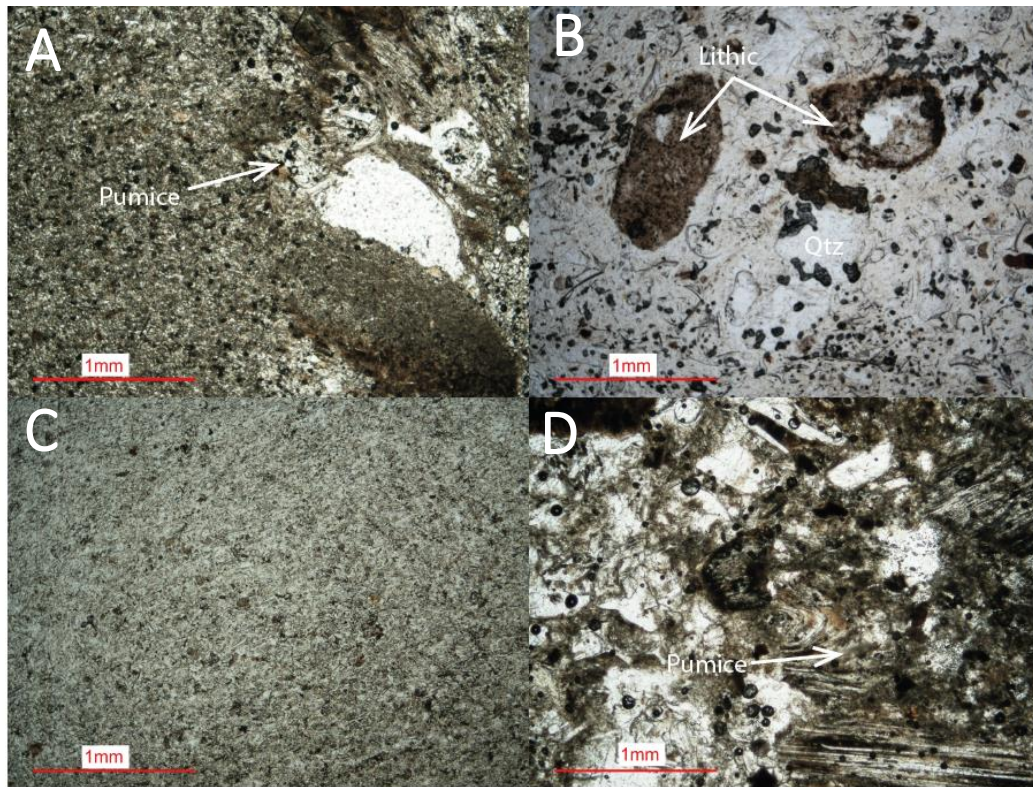

Figure 4.23. Thin section images of F6S2 (A) and R1S12 (B) F2S3(C and D) taken at 4x magnification in plain polarized light are shown.

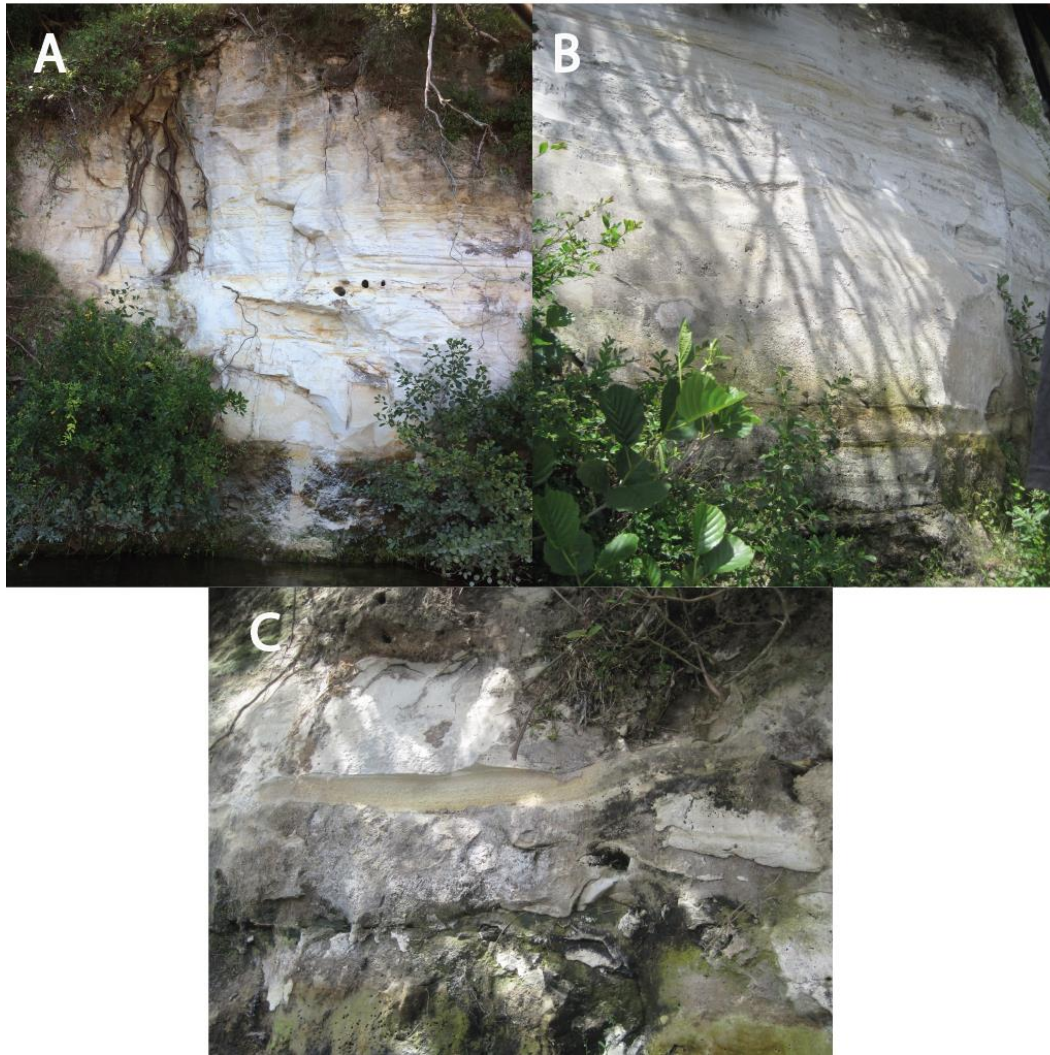

Figure 4.24. Photographs of outcrops found near and at Location 18. A) southernmost outcrop with erosion pipes in silt layer. B) Outcrop of R2S4 located on the southern section of Location 18. C) Outcrop near Day's Park between Location 18 and Station M. Stratigraphic log taken from this outcrop.

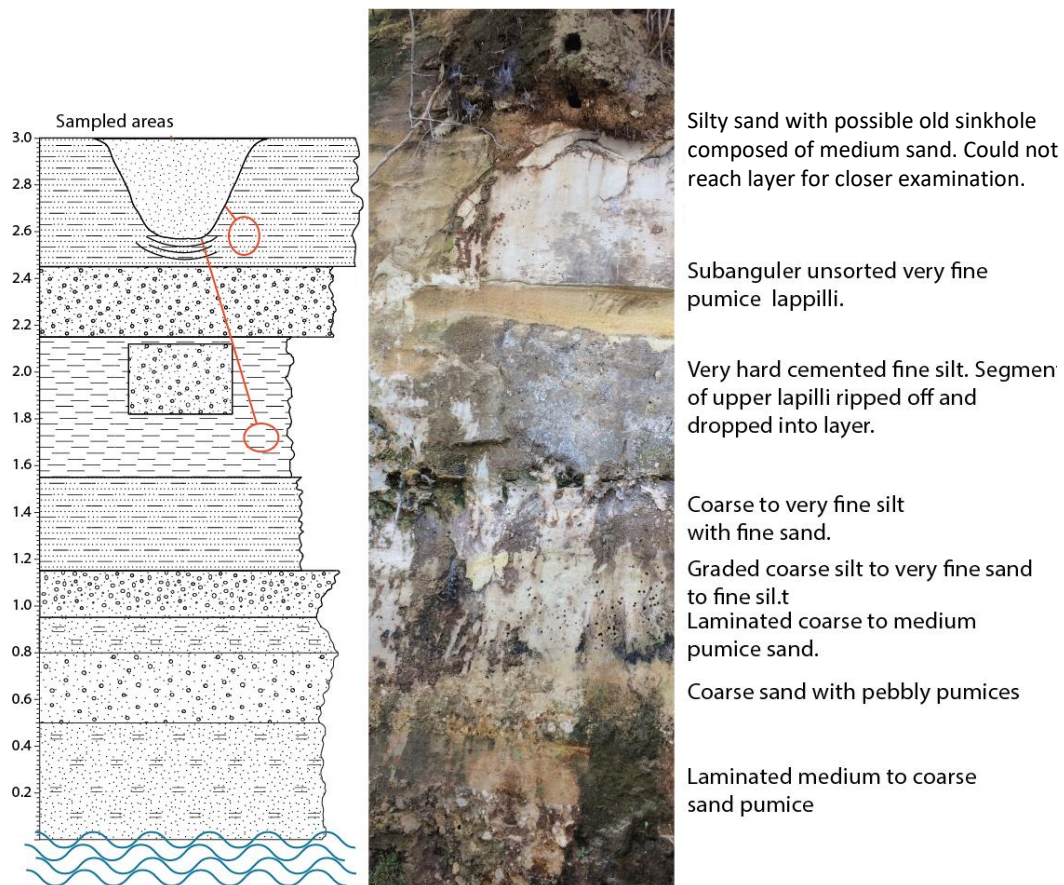

Figure 4.25. Stratigraphic log of outcrop near Location 18 displaying reworked volcanically derived material. Penecontemporaneous deformation seen with sag hole and ripped off pumice lapilli layer that has deposited into lower lying layer.

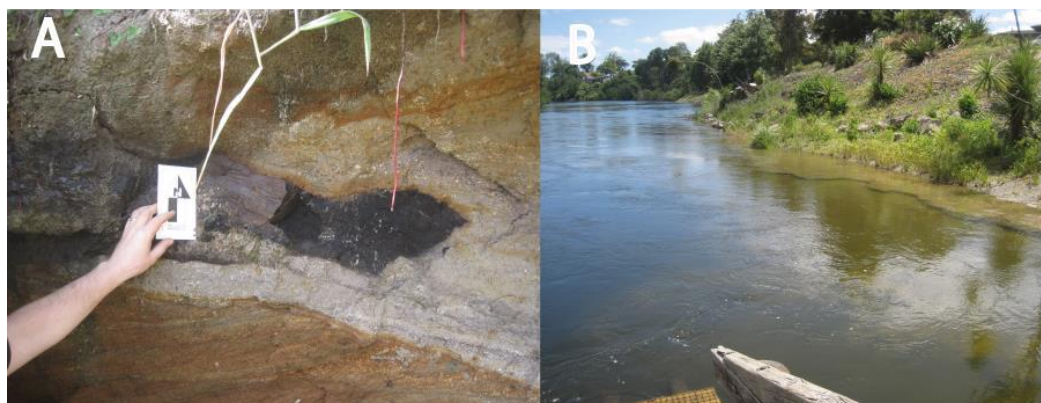

Figure 4.26. A) Photography of decomposed tree in Hinuera Formation outcrop at Location 21 with 10cm arrow for scale. B) Location 20 where the geology drops sharply into the river as seen by the outcrop lines along the bank.

On the western side of the Waikato River at Station N, recent river sediments and Hinuera Formation were found all along the region near the golf course area (Fig. 4.21B). Just past

the Wairere Bridge near Station O fill, Hinuera Formation, and sediments belonging to recent river deposits were present. At Location 23 a small outcrop of Hinuera Formation along the bottom of the footpath contained a strange layer of organic matter that appears to display soft sediment deformation (Fig 4.21A and 4.27). Closer examination showed that overlying medium and coarse sand makes a narrow and deep dip into the organic layer below, pinching the organic layer out in sections. Finer sands and silts shift upward and there is one section where these deposits seem to be almost offset, indicating that this outcrop may be a possible seismite (Fig. 4.27-A2 and A4).

Hinuera Formation is present until Location 24, where a large steep white outcrop is present consisting of silt, clay, and large pumices that have been layered and current bedded indicating Walton Subgroup and classic Karapiro Formation (Fig. 4.28A). The deposit was followed down river into the hills of Braithwaite Park at Location 25 where it is then buried (Fig. 4.28B1 and 2). One metre auger holes throughout the park showed no trace of the deposit. Instead the park consists of sedimentary material and nothing related to ignimbrite or fluvially reworked ignimbrite deposits. After the Braithwaite Park only fill with a few scatterings of sediment were found (Fig. 4.21B).

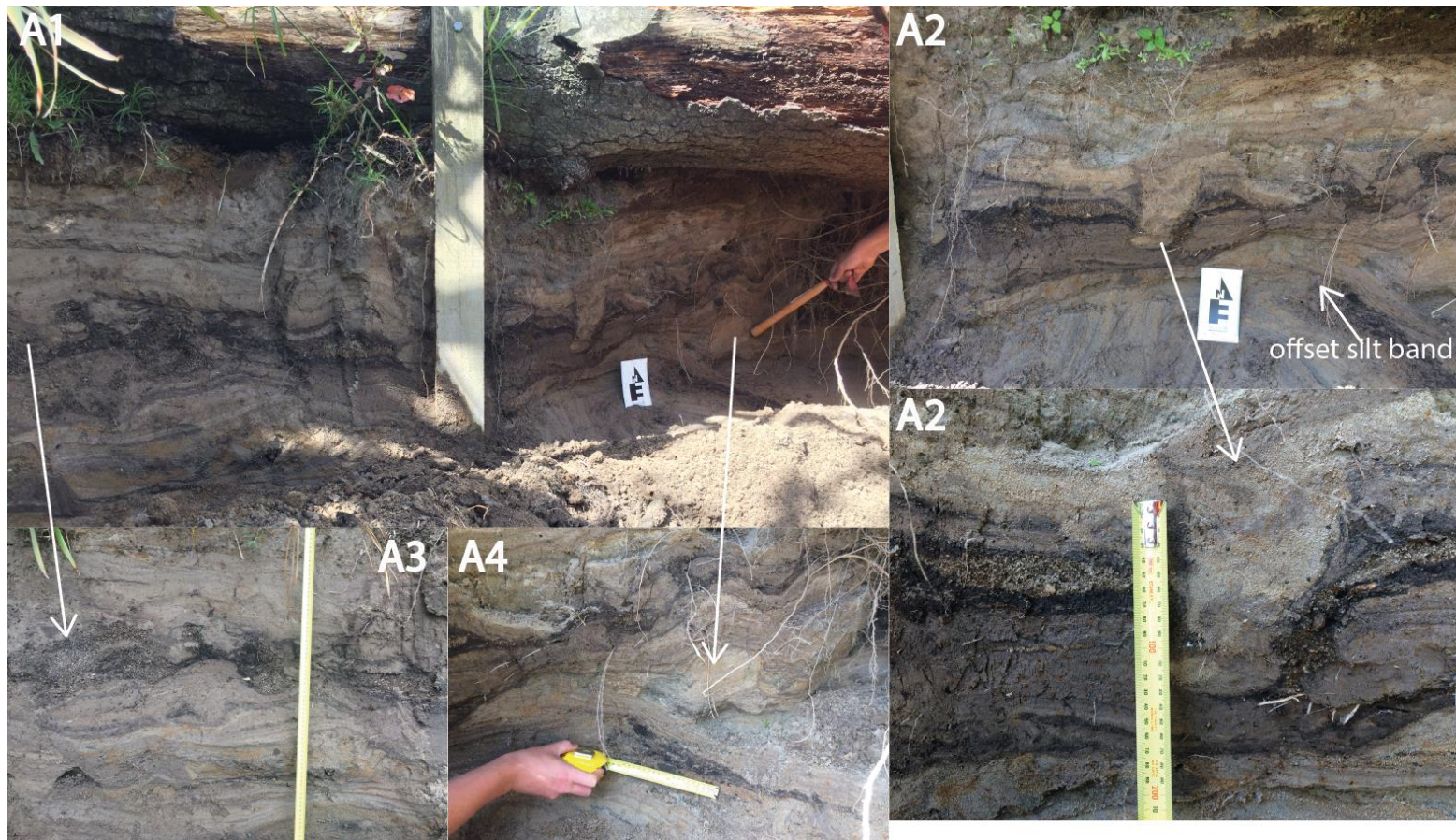

Figure 4.27. 28 Hinuera Formation outcrop at Location 23. A1) Photo of outcrop as a whole with 10cm arrow for scale and hand point to section where offset bed of silt was located. A2) Close up photos of the deep saghole that cuts into the lower more organic unit with a large context photograph above and close up of the material in the hole below. A3) Close up of left side of outcrop showing how the organic layer structure. A4) Photograph of offset silt beds with 10cm tape measure for scale.

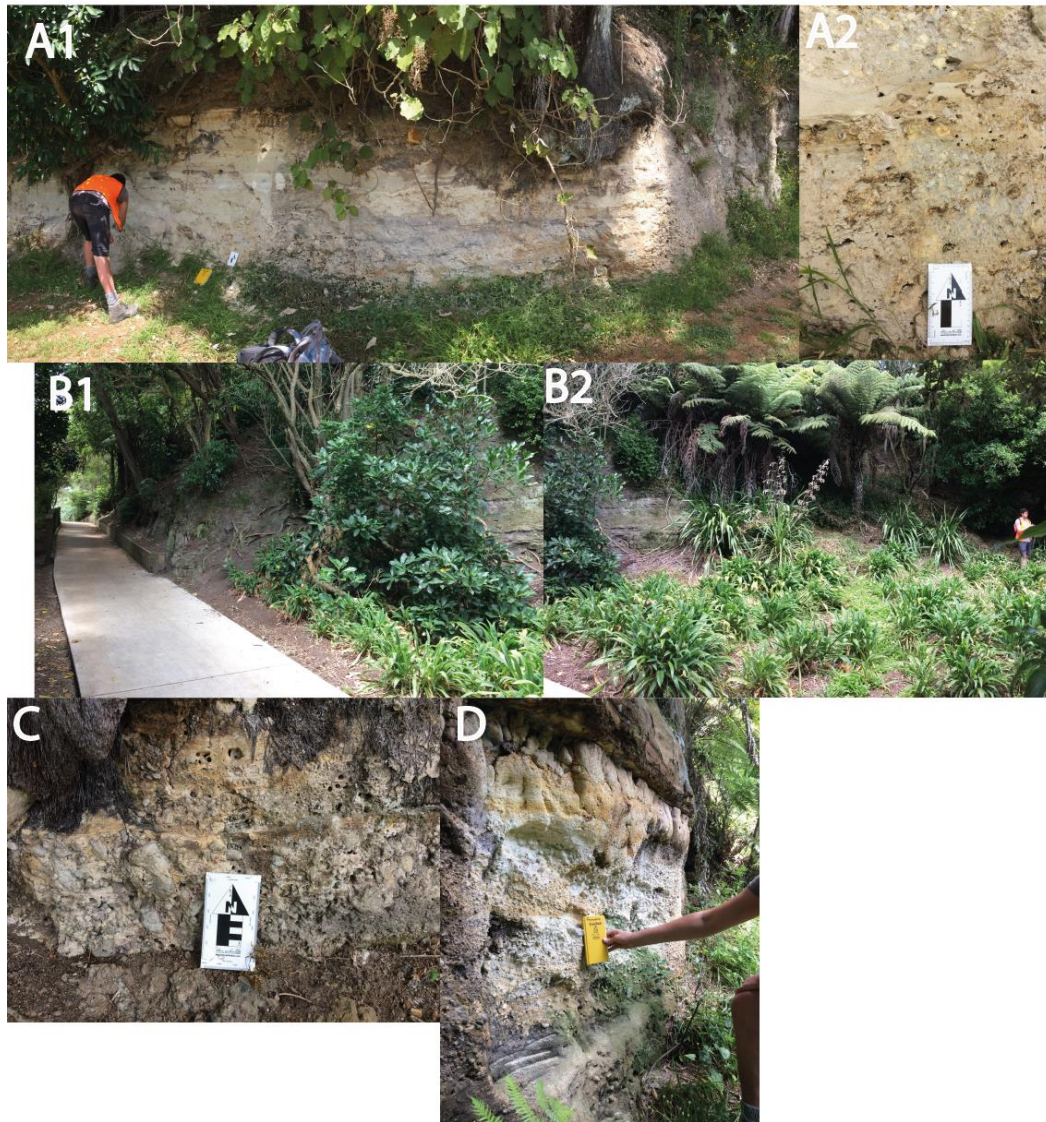

Figure 4.28. Outcrops at Station O. A1) Photograph of outcropped wall at Location 24 with close up of the outcrop shown in A2. B1) Photograph showing where the contact was followed to at Location 25, with where the unit disappears into the hills show in B2. C) Photograph of pumices suspended in clay matrix found under a tree near location 24. D) Outcrop with suspended pumice layer found while following contact between location 24 and 25.

Boat surveys conducted down river from Station O to Station Q had limited outcrops for investigation, resulting in limited field data collection for this region. Most of these outcrops showed Hinuera Formation and other unidentified sedimentary deposits. Only near the Horotiu Bridge at Location 26 was there an outcrop of a clay material with what felt like coarse sands (Fig. 4.28). The material was highly saturated due to being underwater, so samples were collected, dried, and examined as thin sections and under a Scanning electron microscope (SEM) for more information. Thin sections revealed the material contained large amounts of glass shards, but was also mixed with clay

characteristics that are normally found in the Walton Subgroup (Fig. 4.23B; Appendix I). The SEM images showed similar results with few glass shards mixed with clay, further supporting that the material is of a volcanic origin and has been reworked and weathered, possibly indicating Walton Subgroup (Appendix III). Sonar on the boat indicated the river became narrow with a deep depression and hard rock to either side near Kay Road. The description from the boat sonar and the location of this area matched the location where a constricted deep scour hole was found by Wood (2006).

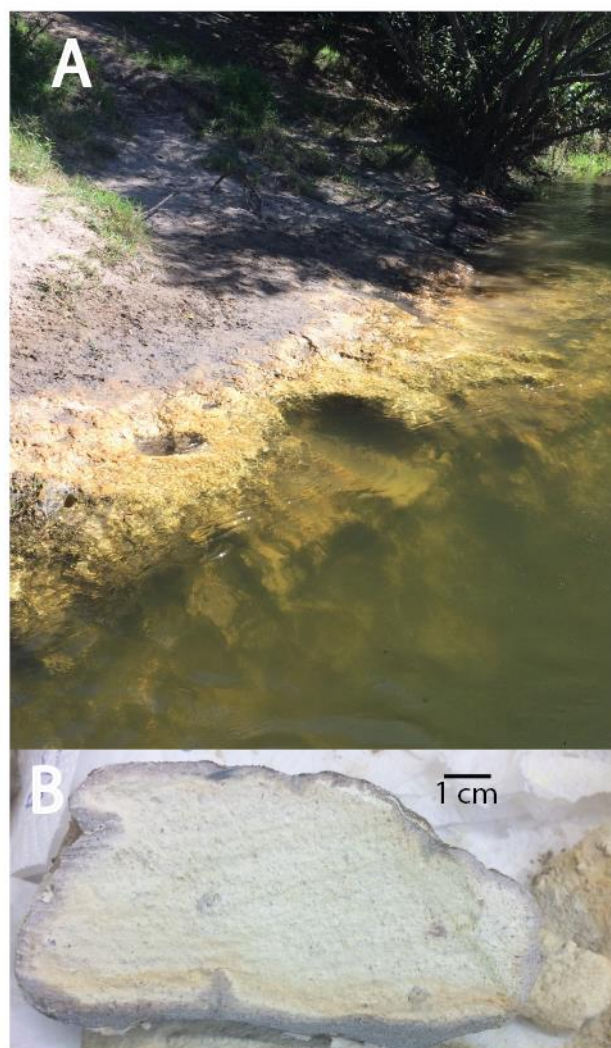

Figure 4.29. A) Submerged outcrop found at Horotiu at Location 26, Station Q. B) Photo of sample taken from the area once it has been dried and coated with a thin layer of resin on the outside to keep it from breaking during cutting.

4.5.3 Known Faults

Two fault zones were discovered within ridges at Rototuna in Ridge 5 and in North Horsham Downs area in Ridge 7 (Fig 4.21A). The initial fault zone that sparked this study, Location

26, was exposed in Walton Subgroup beds along an excavated wall during construction in the Rototuna Subdivision (37°43'24" S, 175°16'40" E). The zone possesses four normal fault traces striking at 356° and dipping between 51-84° with an 89° average dip direction (Moon and de Lange, 2017). The total offset along these fault lines was measured to be 0.5m and offset was observed into the Kauroa Ashes with infilled fault traces composed of material from the Hamilton Ashes. Hamilton Ash was absent above because it had been stripped away during construction, but based on the Hamilton Ash material contained within the traces the timing of movement along this zone can be inferred to have occurred within the last 250 ka (Moon and de Lange, 2017).

Near Horsham Downs, at Location 27, construction along the Kay Road section of the Waikato Expressway Hamilton Bypass uncovered a large complex fault zone (37°42'40" S, 175°15'25" E). Campbell (2017) conducted a study of these faults and found the zone contained numerous steeply dipping normal faults with additional conjugate systems. The faults offset Walton Subgroup material and splinter into the overlying Kauroa Ash Beds but did not progress into the Rangitawa Tephra, indicating that the fault is no longer active. The average dip and dip direction varied greatly due to the conjugate systems present at the site but the total throw measured was 7.4m (Campbell, 2017).

4.5.4 Multibeam and Seismic Results

Multibeam 3D taken near Stations N and P by Wood (2006) were available, but images of River Bends 7 and 9 were not available. Images from Station N show a long drawn out depression with what could be interpreted as a more resistant material along the SW and NE bank of the river (Fig. 4.30). Two seismic survey images along the Waikato River near Station N both show discontinuities in the upper areas of the riverbed. Image F1 is the southernmost survey and shows a deep and narrow profile from south to north. One discontinuity is present in the narrow depression, with a possible second at the bottom, and another discontinuity located north of the first (Fig. 4.30). To the south the density of the material is less than that on the northern side. Image F2 is the northern survey of this area taken at Station N and shows a long draw out change in the riverbed gradient (Fig. 4.30). There are three discontinuities present and a possible change in density from south to north.

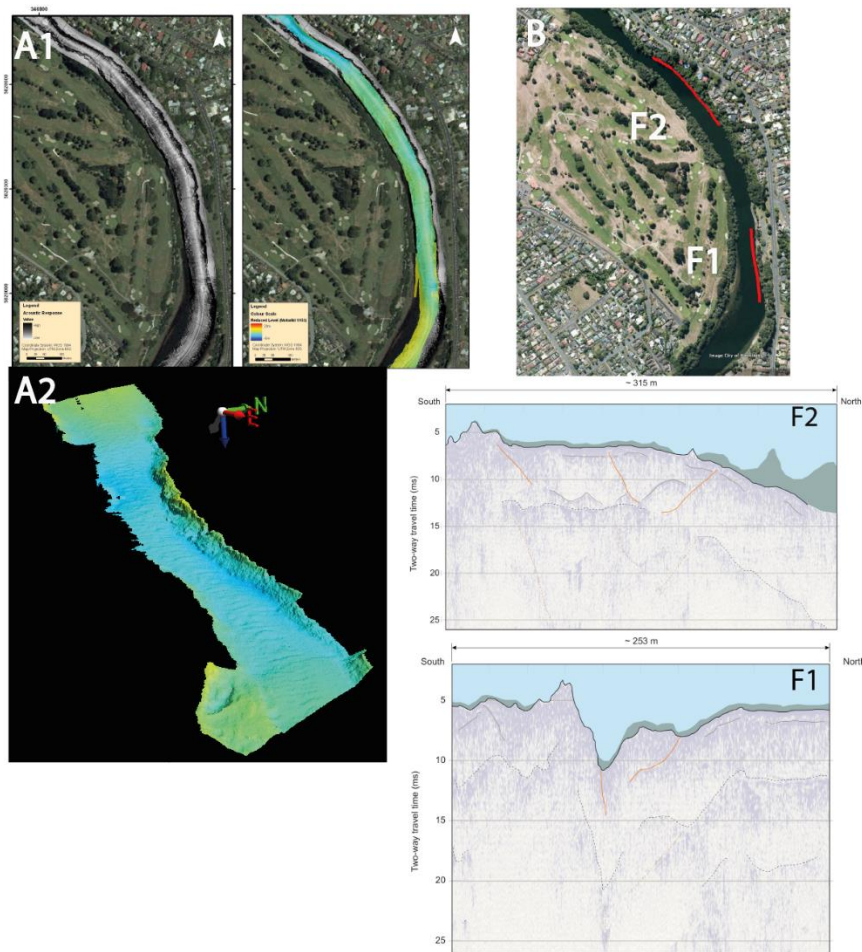

Figure 4.30. A) Multibeam with sidescan sonar images displayed in A1 and the resulting 3D multibeam image shown in A2. B) Map showing where seismic surveys were conducted with results from survey marked as F2 and F1. Note F2 was taken near the 3D multibeam image, and shows a change in density of material with some failures. F1 shows a knickpoint with discontinuity contained within the depression.

No 3D multibeam images were available for the area near Station O. However two seismic surveys were conducted between Stations P and Q. The first multibeam image taken along the river bed near Kay Road near the southern section of Station P shows multiple lineations and outcrops of either indurated or differing geology (Fig. 4.31). There is a main lineation in a NW orientation which consists of a lithology that is either harder than its surroundings or different along the NE bank of the Waikato River. To the south there is a second NE oriented lineation that cuts through the centre of one the main depressions along the SW bank and appears to potentially cut into the material at the top of the NE bank. The second lineation is located up river from the first depression and consists of a second deep depression with an upside down T-shaped outcrop in the middle of it (Fig. 4.31). Sections of this outcrop are oriented to the NW and the NE, making the T-shape and

showing similarities to the lineations upriver in the same area. The depression is deepest along the front of this outcrop. In between these two depressions is an area of constriction along the river bed with what looks like another NE oriented lineation. These depressions and constrictions match those seen on the boat sonar during field surveys, and thus show that the river bed morphology has not changed much over the last 10 years. No seismic image was available at this exact location however one is available just north of this location (Fig 4.31). The seismic survey image shows a trough like depression containing two discontinuities within it and a third one located just north of the trough (Fig 4.31). There appears to be a slight change in the densities from south to north, with the south containing 4 areas of high density and the north section containing only two (Fig 4.31)

Up river near Osborne Road 3D multibeam images show another constricting depression present along the river bed with an indurated or possibly differing geology along the banks to the east and west (Fig. Fig 4.32). Scouring appears to occur mostly along the SW side of the bank with a strong lineation occurring in the NW-SE direction (Fig 4.32). The seismic image 1326-F2 shows a larger drawn out trough shape with no discontinuities present (Fig 4.32).

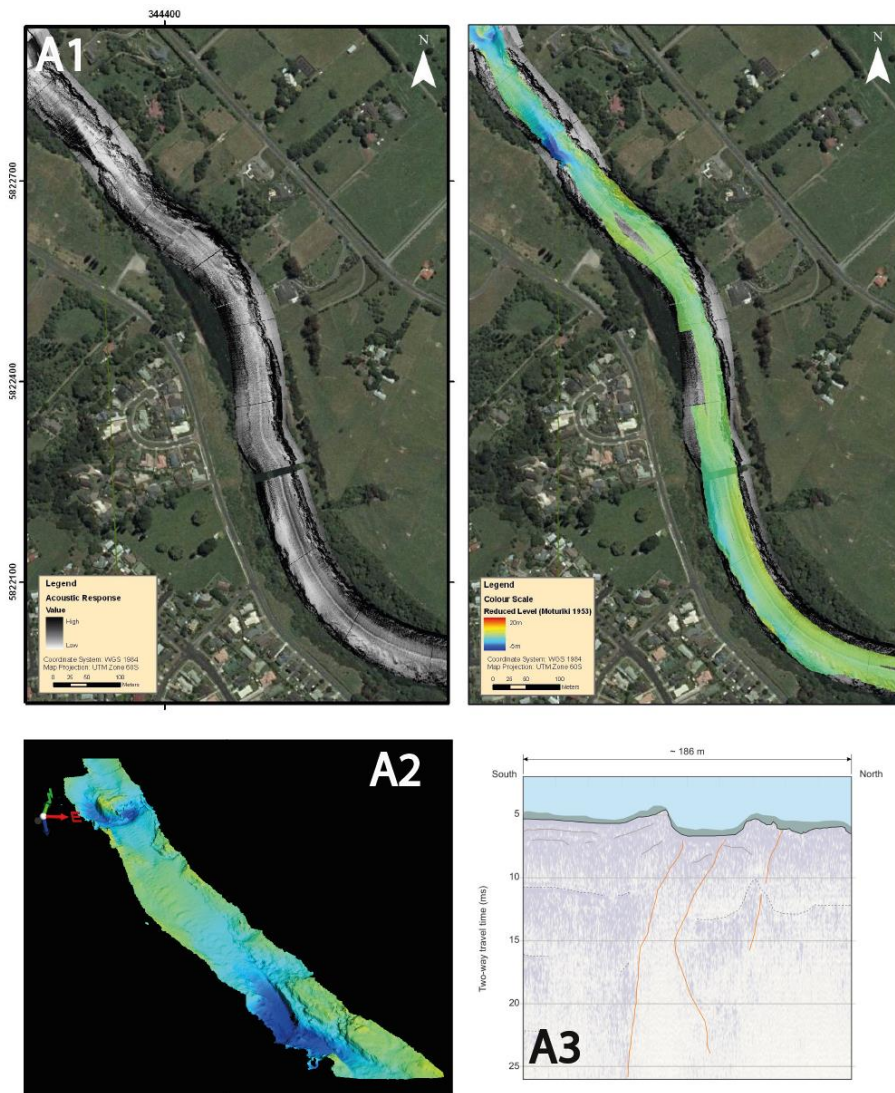

Figure 4.31. Results of sidescan, multibeam, and seismic surveys. A1) Location of where the sidescan and multibeam test with the resulting 3D image presented in A2. A3) Seismic Survey results taken along the region showing a trough shape depression with two large discontinuities.

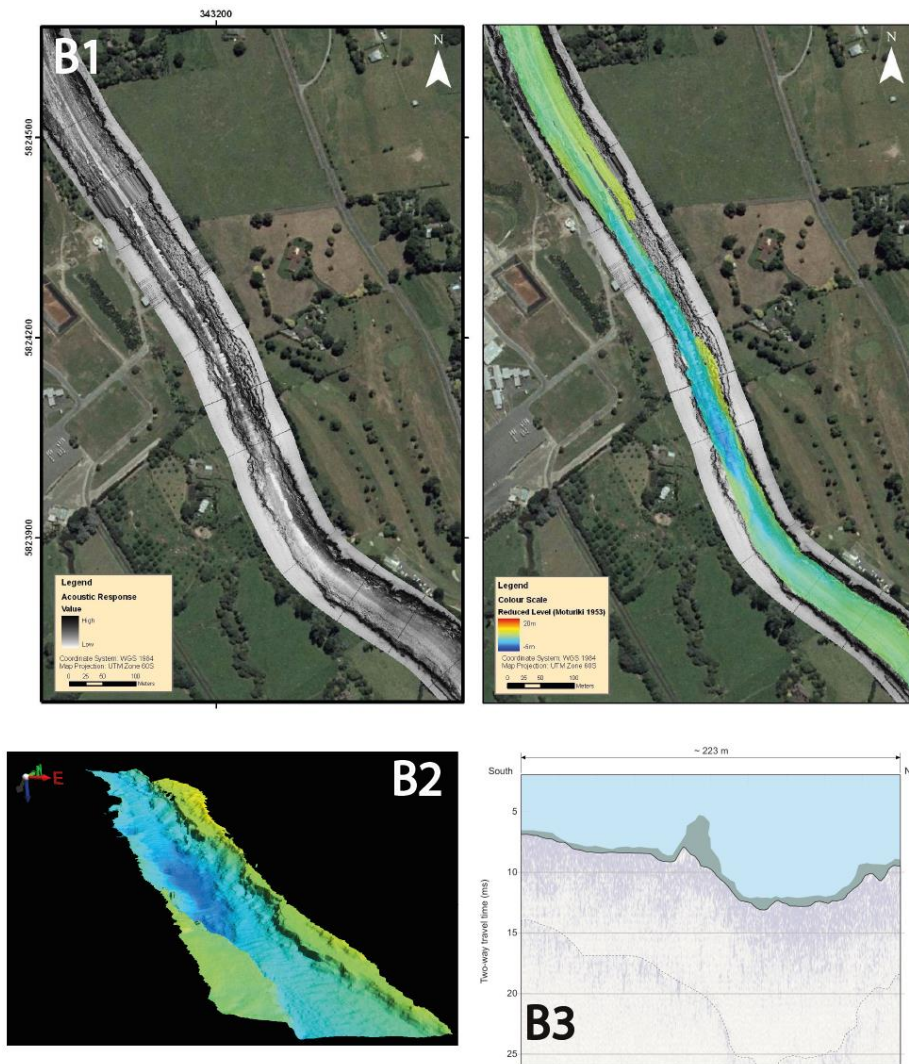

Figure 4.32. Results of sidescan, multibeam, and seismic surveys. B1) Location of the sidescan and multibeam test with the resulting 3D image presented in B2. B3) Seismic Survey results taken along the region showing a trough shape depression with two large discontinuities.

4.6 Areas of interest that were non-conclusive

Attempts were made to gather geological information along the Waikato River near Drainage D2, along River bends 4 and 5 near the Hamilton Gardens, along the Central Hamilton area, and near Horotiu between River Bends 10 and 11, but many of these sections were inaccessible, having been heavily altered during development, or blocked by heavy vegetation (Fig. 4.1). In the north outcrops became limited along the river as the topography become more and more subdued. In the south and central Hamilton regions urban development and heavy vegetation growth were the issues. LiDAR data shows a strong linear drainage system (D2) nestled between a system of similarly oriented ridge lines, labelled as Ridge 4 (Fig. 4.1). At the outlet of D2 is a large floodplain that shows a slight constriction just before the Cobham Drive Bridge at the end of Ridge 3. Shortly after

this the river takes shifts to NW direction marked by major river bend 5 then takes another bend at 6 just before Anzac Parade (Fig. 4.1). These features have similarities to Hammond Park, and Day's Park regions, but limited evidence was able to be gathered, consequently no information was presented for these areas. However, the area is still of interest for future research.

4.7 Concluding Remarks

Basic observations of the Waikato River shows that the river follows a general NW trend across the Hamilton Basin, but with a series of sharp, near-orthogonal, bends along the way. Such bends can be observed at Stubbs Road, Hammond Park, Hamilton Gardens, Hamilton City, Day's Park, Braithwaite Park, and Horotiu (Fig. 4.1). From the LiDAR, multiple large NE to NNE trending ridge lines, Ridges 1-9, can be observed cutting through the basin and intersecting the Waikato River where many of these river bends occur (Fig. 4.1). Geomorphology at these bends consists of a pattern with upriver aggradational zoning, seen through broad and unpaired terracing and floodplains, accompanied by downriver degradation as indicated by incision of the Waikato River and knickpoints observed in the multibeam, and seismic data. Field investigations revealed stratigraphic patterns of offset terraces at Stubbs Road, Hammond Park, Day's Park, Braithwaite Park, and possibly Horotiu with units often switching between Ignimbrite or Walton Subgroup to Hinuera Formation. The bearing of offset between stratigraphic units at Stubbs Road and Hammond Park show similar bearing of offset to those measured from the multibeam data for those areas. No measurements were able to be compared near Day's Park. Multibeam 3D image data corroborates the evidence of possible change in stratigraphy as indicated by abrupt changes in riverbed geomorphology located along these bends, where the upriver sections show a more indurated material often separated by a lineation with a "scour hole", now discovered to be knickpoints on the downriver side. Locations for this can be seen at Stubbs Road, the double bends at Hammond Park, and north of Braithwaite Park.

A general trend in the stratigraphy observed though the Hamilton Basin along the Waikato River is that ignimbrite is present through most of the southern half of the field area, with little Hinuera Formation, Whereas in the north section there is more Walton Subgroup and again bits of Hinuera Formation. It must be mentioned that limited Hinuera Formation outcrops could be due to its unconsolidated nature and easy erodibility. Also, many sections along the river had dense vegetation causing observations to be limited in many sections. Further limitations were due to the extensive urban development which has placed large amounts of fill along the river to make more land to build on.

DISCUSSION AND CONCLUSION

5.1 Introduction

In this chapter interpretation of remote sensing, field survey, multibeam, and seismic results will be presented. First I will discuss the Junction Magnetic Anomaly and how it produces other structural features that may be influencing the Hamilton Basin. Section 5.3 will present an overall interpretation of the Waikato River's geomorphology and explain how many of these features are signatures of tectonic geomorphology. Discussion regarding the three specific field areas of focus will be presented in Sections 5.4-5.6 with an opening statement of the overarching interpretation observed at each area based on the field, LiDAR, seismic, and multibeam data followed by specific pieces of evidence that lead to these interpretations. In Section 5.7 I will discuss how the findings from these particular areas indicate a large structural fault zone system as well as how that system may have formed and is currently being influenced. Attention will be given to future research topics based on these findings given the uncertainty regarding the specific geophysical processes that may be contributing to the formation of the fault systems observed in the Hamilton Basin, in Section 5.8.

5.2 Junction Magnetic Anomaly

The Junction Magnetic Anomaly (JMA) marks a major N-S oriented basement suture coinciding with the Waipa Fault, and creates the western boundary of the Hamilton Basin marked by high hills. Though the Waipa Fault is associated more with the subduction processes that occurred along the Gondwana margin, there is evidence that right lateral movement was occurring along the fault at least into the Paleogene as was discussed in [Section 2.81](#). It has been proposed by Hunt (1978) and Kirk (1991) that a secondary NE oriented fault, named the Taupiri Fault exists along the base of the Hakarimata Ranges and is connected to the Waipa Fault (Fig. 2.16). The existence of this fault helps to explain the angular deviation of the Hakarimata-Taupiri block from the rest of the Murihiku Terrane while also maintaining the location of the Waipa Faults along the JMA, and the anomaly itself. It is possible that both the Waipa fault and the Taupiri Fault may be influencing the structural geology of the Hamilton Basin. LiDAR data shows that the ridges found throughout the Hamilton Basin have similar orientations as the Taupiri Fault and contain

complex normal fault zones in some locations (Moon and de Lange, 2017; Spinardi et al., 2017; Campbell, 2017)

5.3 Geomorphology of the Waikato River

Fluvial systems are used as important tools to understand the interaction between tectonic influences and geomorphologic processes. In order to discuss results gathered from remote sensing and field expeditions we must first consider key features of tectonic geomorphology and what they mean for the Hamilton Basin. Background regarding these features was discussed in Section 2.7. Key geomorphological trends along the Waikato River observed from the LiDAR, field data, multibeam, and seismic results include a rectangular drainage system, areas of aggradation as seen by both floodplains and wide paired or alternating terraces, and areas of degradation as seen by sections of river incision, abandoned/capture channels, and knickpoints observed in the multibeam and seismic data.

The 11 different major river bends with angles varying between 140 and 97° indicate that the Waikato River possesses a rectangular drainage pattern (Fig. 4.1). Bends in rivers can form through many different fluvial processes, but rectangular drainage patterns are formed through the influence of joints, faults, or other discontinuities in the underlying geology (Howard, 1967; Schumm et al., 2000; Burbank and Anderson, 2012; Fryirs and Brierley, 2013). Located at each of Waikato River bends are areas of aggradation that become constricted on their downriver section and then switched to degradation. Many of these constricted locations occur upstream of a river bend such as seen at Stations A, I, L, and between N and O. Regions of aggradation contain features such as floodplains, terraces, and wider river profiles, while areas of degradation contain knickpoints, incised regions, steep banks, and narrower channels (Schumm et al., 2000; Burbank and Anderson, 2012; Fryirs and Brierley, 2013). Incised areas often occur in the regions of the major River bends such as seen at River Bend 1, 3, 4, 7, 9, and 10. Bends 5 and 6 were not included because of limited data.

Coupled with many of these major river bends are scour holes which, when compared to the seismic data, are actually knickpoints. At the time Wood (2006) equated the formation of these holes to a differential strength between the underlying geologic material causing sections of the river bed to be eroded away more easily than other sections. After the discovery of the first fault zone in the Hamilton Basin these multibeam images were revisited, and it was then observed that there was a pattern occurring. In almost every location where the geomorphology inferred a fault a scour hole was also in the same

location, resulting in these scour holes being reclassified as knickpoints. Further evidence of this hypothesis is also contained in the seismic images where profiles of the river show sharp gradient changes in many locations along the river particularly near Stations B, I, K, and P, further supporting this hypothesis (Fig.4.5A, 4.13A, and 421A).

5.4 Stubbs Road

I hypothesise that the abrupt orthogonal nature of the Waikato River bends along Stubbs Road is due the presence of a fault zone acting on the river's path. Supporting evidence for this hypothesis comes from the geomorphology, field surveys, and the fault outcrop along the western bank, and can be confirmed with the 3D multibeam images and seismic surveys (Fig. 5.1).

Geomorphological observations at Station A shows the Waikato River has a wider profile and is flanked by terraces on each side as it approaches Station B. Between Stations A and B the river becomes constricted, showing it has incised. The river then takes a sharp turn, and forms a single terraces, first on the eastern bank (Station C) and then the western (Station D) as it progresses down river. From these geomorphic features it can be interpreted that the section of the Waikato River along Station A experienced a period of aggradation and then changed to degradation at the location of the river bend at Station B. It is true that changes in flux, sediment or just differences in material strength can influence a river to change from a floodplain to an entrench segment. However, the aggradational segment observed at Stubbs Road has a defined bottleneck that clearly stops at Station A. Normally if there was a change from aggradation to degradation caused purely by fluvial processes, and not a seismic event, we would be able to track the progress of the river's change in path with the terraces to the south and possibly to the west. What is seen instead is a choke point and an abrupt change from aggradation to degradation, more consistent with tectonics, which cause abrupt fluvial shifts due to uplift or down drop. In such a situation, aggradation happens when the local base level of the fluvial geomorphic system has lowered or become blocked causing the fluvial system to slow and deposit material as much as it can in order to re-establish its equilibrium baseline. Along the uplifted section the opposite would occur with the river incising itself in order to lower its elevation to the sustainable local base line forming an area of degradation (Ouchi, 1985, Schumm et al., 2000; Burbank and Anderson, 2012; Fryirs and Brierley, 2013). As discussed in Section 2.7, if a river is flowing perpendicular to the strike of a fault plane and in the opposite direction of the planes dip direction, the flow path can become blocked or diverted resulting in back flooding (aggradation) along the lowered block and incision (degradation) along the uplifted block (Ouchi, 1985; Schumm et al., 2000; Burbank and

Anderson, 2012). Similar signals have been observed at the Baghmata River in India (Jain and Sinha, 2005).

Looking at the geomorphology of the large single terrace at Station D it can be observed that each of the smaller terraces has a similar orientation to that of the abandoned N-S channel, A1 (Fig. 4.5A). Field investigations and rock samples showed much of the western bank consists of Ongatiti Ignimbrite topped by Hinuera Formation along on the tallest terraces at Location 4 and 5, whereas across the river on the eastern bank at Station C Hinuera Formation and Taupo Pumice Alluvium were found along the terrace except along the northern section at Location 2 where Walton Subgroup and ignimbrites were found. The difference in geological formations when comparing the western to eastern terraces can be interpreted as evidence of disruption or even offset (Fig. 4.5B). The bearing of offset between the outcrop of the fault at Location 1 to the outcrop of the ignimbrite/ Walton Subgroup on the eastern terrace at Location 2 was 66° and came in close alignment with the lineation found in the multibeam data. Though there is almost 7° difference between the bearing of the lineation along the riverbed and the terrace offset, they it are still within a reasonable proximity to one another, with possible error being contributed by the observed outcrop not being at the exact contact location, alteration due to erosion and/or development (Fig. 4.5A).

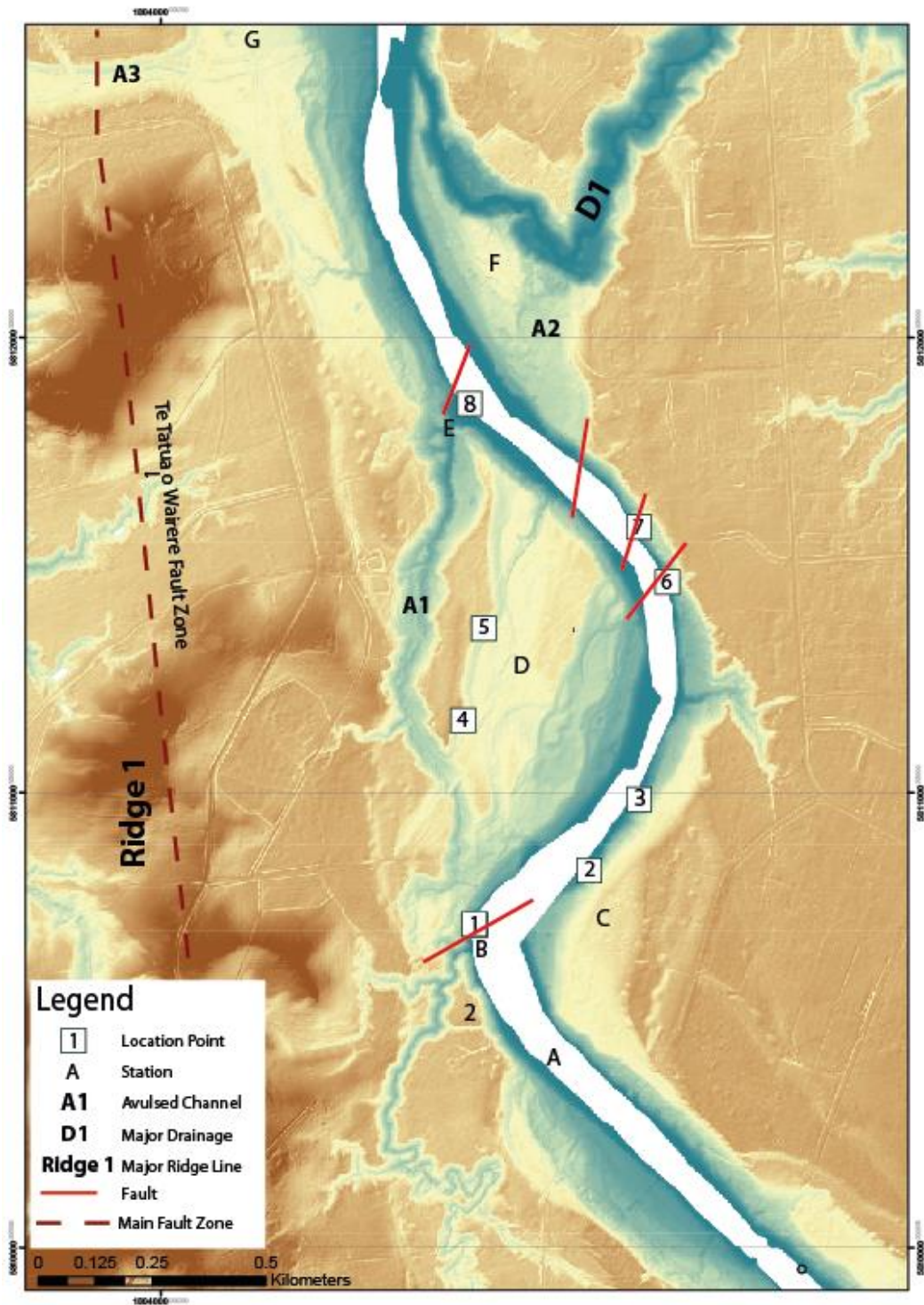

Figure 5.1. Geomorphic map of Stubbs Road showing faults lines, both inferred and exposed, marked as the small red lines in relation to the location of the proposed Te Tatua O Wairere Fault Zone.

The large N-S channel, A1, is interpreted as an avulsed river path once taken by the Waikato River, but was cut off either during a seismic event or by creep along the fault zone. Evidence for this interpretation can be seen in the channel's “inlet” width and depth indicating it has a well developed nature. Additional evidence also comes from A1’s

alignment with other gully systems such as the small western gully at Station A and the major drainage system, D1 to the north. The inlet of A1 is in alignment with the outlet of the smaller gully at Station 1, and the outlet of A1 is in alignment with the D1 to the north and its abandoned outlet, A2 (Fig. 4.5A). The A1 channel also has evidence for aggradation/degradational patterns as seen in the change from a narrow inlet with no terraces near Station B, to an outlet area with terraced sections near Station E. This pattern is similar to other locations along the modern Waikato River, further indicating the river travelled along this path. It is interesting to see that the avulsed channel contains Ongatiti Ignimbrite, confirmed by both distinct features in field outcrops, collected samples, and the thin sections, but along the eastern bank the ignimbrite is only present along half of the bank between Location 2 and 7 then switches again to sediments upriver near Station F (Fig. 4.5B). This alternating nature of geologic deposits may indicate other faults nearby, suggesting that the system present at Stubbs Road may be a part of a larger fault system. It is important to note that D1 on the eastern side of the river also contains a sharp bend with an abandoned outlet (A2), indicating a change in the tributary's direction. The tributary also beheads other drainages that have a similar orientation the Waikato River's general NW trend and are also oriented orthogonally to the tributary, showing a sudden change in topography that caused a drastic change in direction, a classic signature of tectonic geomorphology (Schumm et al., 2000; Burbank and Anderson, 2012).

At Station B multibeam imaging shows a NE lineation across the river bed with a bearing angle of approximately 73° and a secondary plane oriented at about 41° , creating a step feature. To the north of the NE plane a scour hole can be observed, and what can be assumed as either harder or different material is present to the south (Fig. 4.12). Though this hole was originally thought to be a scour depression due to the erosional processes of the Waikato River, when paired with the seismic survey data it can actually be considered as a knickpoint. Knickpoints can form through changes in geology but they also mark the location of a fault plane (Burbank and Anderson, 2012). Seismic survey data also shows a deep entrenchment (knickpoint) located between where what could be possibly two materials consisting of different densities exist on either side of the depression (Fig 4.12). Further evidence for a fault plane also comes from the interpretation that there is a change in the geological material from south to north as indicated by noneroded material along the southern section of the NE lineation and the change in lithologies observed on land (Fig. 4.12).

A small exposed fault plane is located along the western bank of the Waikato River at the crest of the bend and is further evidence of tectonic influences acting upon the Waikato

River (Fig. 4.11). The plane is oriented dipping 85° with a dip direction of at 47° SE and is conjugate to the main fault trace inferred along the riverbed and even the secondary step feature along the bed (Fossen, 2010). However, Campbell (2017) found evidence of similar features and conjugate faulting at Kay Road, a further indication that the tectonic features at Stubbs Road is a part of a large fault zone system.

From the geomorphic, field, multibeam, and seismic data it can be interpreted that tectonic influences are acting upon the Waikato River at Stubbs Road and influencing its drainage pattern. When a river is traveling perpendicular to a fault it will either form an area of aggradation or degradation along the footwall or hanging wall, depending on its orientation to the dipping fault plane to the direction of flow from the river (Ouchi, 1985, Schumm et al., 2000; Burbank and Anderson, 2012). We know the orientation of the pane is approximately 73° , a NE-SW orientation, and we can see the Waikato River is traveling in NW direction then changes to NE. The change in direction tells us that the Waikato River is flowing almost perpendicular to the fault plane and hitting the fault line, causing the southern area at Stubbs Road to have an area of aggradation and the northern degradation (Fig. 5.2). There is no clean measurable evidence to help determine the main type of movement along this fault zone, but given evidence of a complex normal fault zone located in the north of Hamilton, it can be inferred that the dominant movement is probably normal faulting (Moon and de Lange, 2017; Spinardi et al., 2017; Campbell, 2017). However, due to the presence of a conjugate faulting system there is also potential for reverse faulting.

From the data and patterns observed, it can be assumed that the Waikato River once took a more N-S path, but a seismic event caused either the southern section to drop or the northern section to rise, creating an obstacle that caused in the Waikato River to either slow or back flood, as seen by the wider profile and paired terraces. Over time the Waikato River was able to makes its way around the obstacle and slowly erode it away, as seen by the eastwardly stepping terraces.

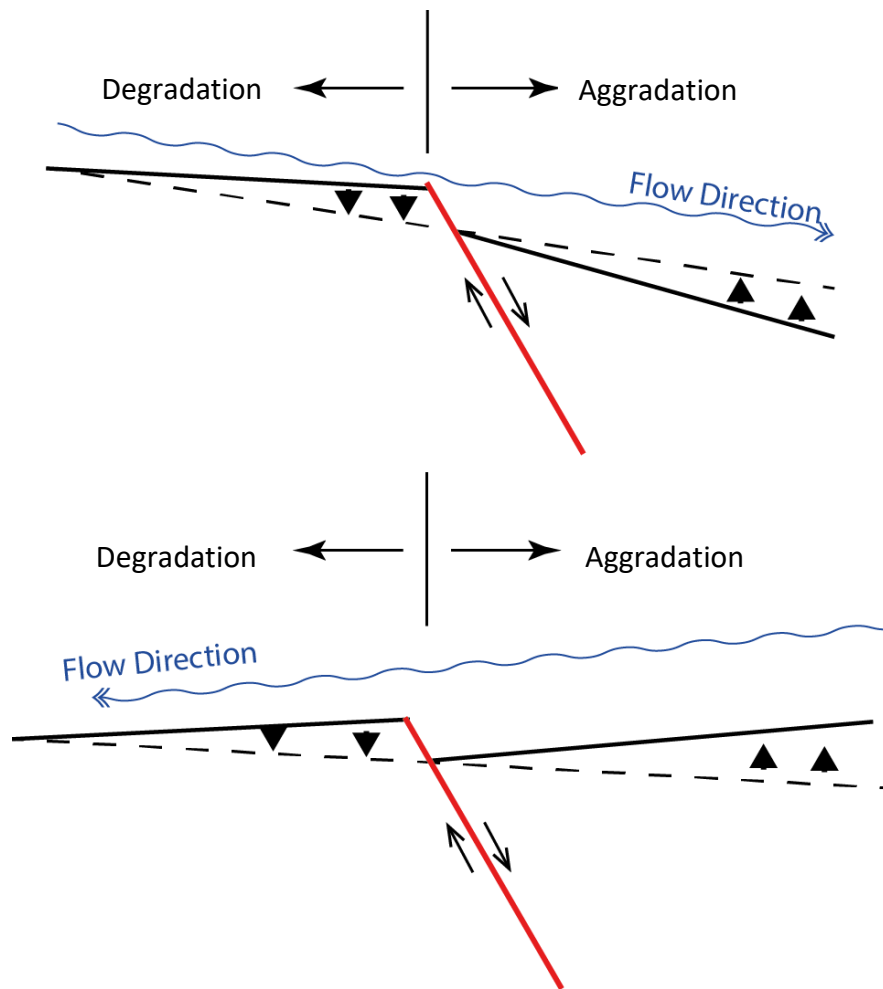

Figure 5.2. Diagram showing how river direction across a fault plane can result in different areas of aggradation and degradation. Diagram is based on similar one by Schumm et al. (2000).

It can be postulated that the movement along this fault was within the last 20 ka because the uppermost terrace at Station D, which is composed of Hinuera Formation, has been eroded by the avulsed A1 channel. Across A2, the abandoned outlet of D1 cuts through between outcrops of ignimbrite and Hinuera Formation at Station F. These two avulsed areas are aligned showing a relationship and a pattern between these two channels. If a seismic event caused the Waikato River to become blocked and/or change its direction it would mean, based on the erosion of Hinuera Formation Terraces, that the event would have occurred after the Hinuera Formation was deposited.

5.5 Hammond Park

Similar to Stubbs Road, the orthogonal double bend system located at River Bends 3 and 4 is also interpreted as being influenced by faulting (Fig 5.3). Similar geomorphic patterns to the ones observed at Stubbs Road are present, the only difference is the double bend system occurs along a ridge (Ridge 1) which previous studies and other observations are

indicating might be a main fault zone (Fig. 5.1 and 5.3; Moon and de Lange, 2017; Spinardi et al., 2017; Campbell, 2017).

At Station H, the Waikato River orientation changes from northward to westward at an angle of 89°, creating an orthogonal bend in the river similar to Stubbs Road. However, unlike Stubbs Road the geomorphology along the river bends first occurs when the river intersects Ridge 1, a N-S oriented ridge line, indicating that the ridge is influencing the river's path (Fig. 4.1). Ridge 1 is a large topographic and geomorphic feature with few low lying areas. As seen in Figure 4.1 the ridge extends through the Stubbs Road area along the western bank of the Waikato, then crosses the river and continues until it stops near the University of Waikato. It is strange to have such a large topographical feature be significantly cut by the river in only a few sections without influence from differential uplift/downdrop (Boulton and Whittaker, 2009). For example ridges are the boundary features when viewing catchment systems. When rivers meet an area of significant higher elevation their path will generally change based on the topographic limit (Fryirs and Brierley, 2013). Ridge lines can be eroded down over time, but generally speaking the whole ridge line would have a more subdued appearance, unlike Ridge 1 where the Waikato River Cut through only a few low lying area. However, specific sections of a ridge lines or high topographic features can be eroded when there changes to rivers and drainage systems and that where these low lying areas occur coincides with the bends in the Waikato River and transition points from aggradational/degradational areas (Fig. 4.13A). Based on evidence from Campbell (2017) the ridge line alone can be a geomorphic indication of a fault zone, therefore it is possible that the ridge in the Hammond Park area is another fault zone similar to the ones found at Ridge 5 and 7 (Moon and de Lange, 2017; Spinardi et al., 2017; Campbell, 2017). However, this alone is not enough information to confirm or deny this possibility so more evidence for this hypothesis is discussed below.

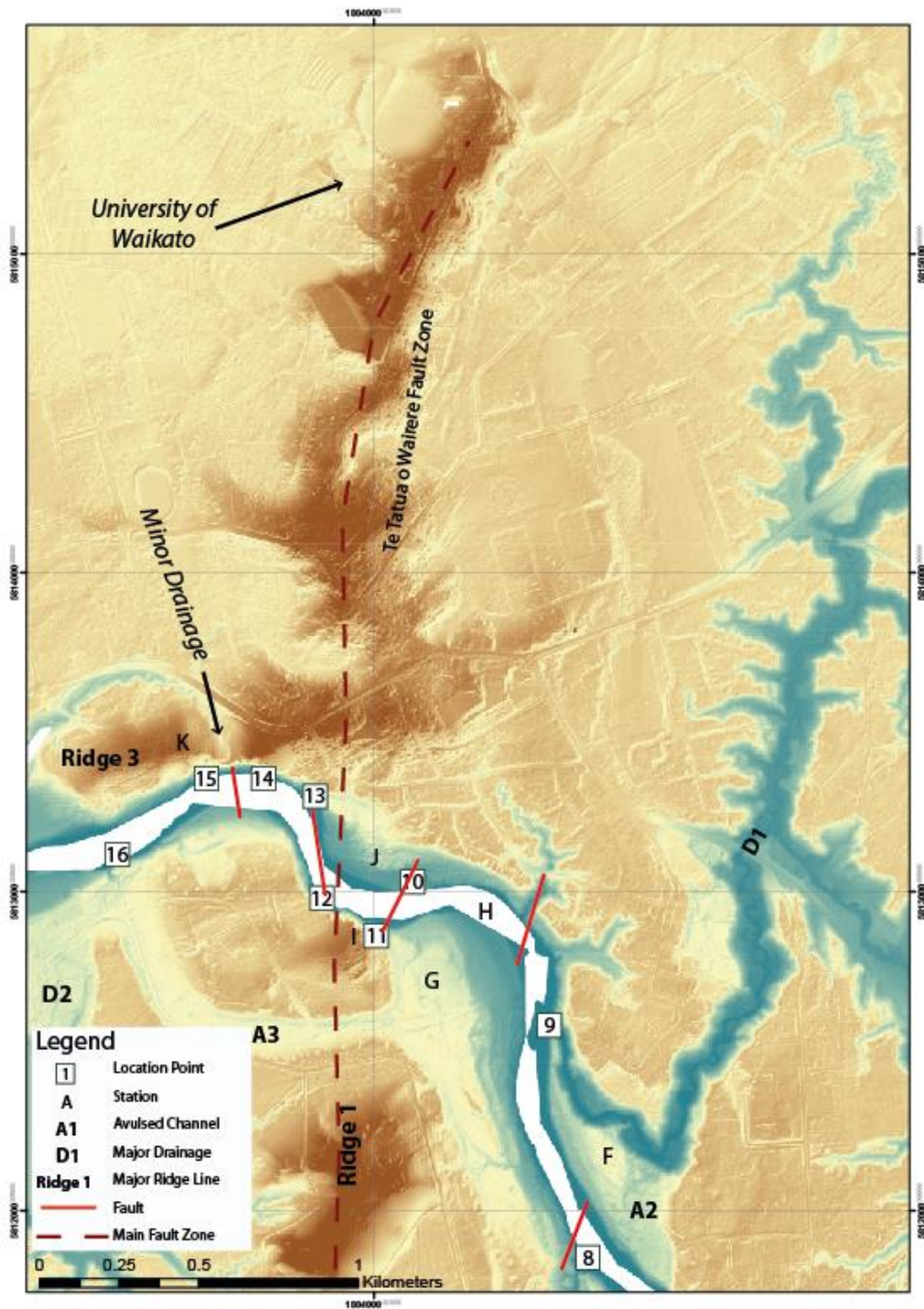

Figure 5.3. Geomorphic map of Hammond Park showing faults lines, both inferred and exposed, marked as the small red lines in relation to the location of the proposed Te Tatua O Wairere Fault Zone.

Station G marks an area of aggradation similar to the one observed at Stubbs Road. Following the location where the river becomes constricted, near Station J, an area of degradation occurs as seen by the narrow river path flanked by steep cliffs and a single sided terrace. After Station K aggradation occurs again as seen by the large floodplain and terraces near D2 (Fig 4.1). The presence of terraces often flanking a river, floodplains, and

wider cross sections are all evidence of aggradational processes occurring. In the case of Hammond Park, river terraces are flanking the Waikato River along both sides from Stations F to G. Evidence for degradational processes occurring includes the constriction of the Waikato River, near Stations I and J, coupled with the river cutting through a large ridge line beginning near Station I and ending near Station K. Further evidence for degradational processes can also be seen in the multibeam images and seismic data where knickpoints are present near the border of each of these geomorphic areas (Fig 4.19 and 4.20). The geomorphic data shows that the Waikato River has experienced a time where it was either slowed or blocked as indicated by the aggradational patterns. The river then incised as it either broke through or diverted around the obstacle as seen by the degradational area. Evidence for a similar event occurring to the more recent one that has resulted in the currently location of the Waikato River can also be found in the geomorphology along an avulsed river channel labelled as A3. A3 also contains a sharp orthogonal bend, changing from a west orientation to north. Large terraces at Station G are present leading up to A3's inlet, followed by constriction at the ridge line near Station I, and wider paired terracing at its outlet near D2, another indication of an alternating aggradation/degradation patterns (Fig. 4.13A).

Further evidence for tectonic influences on the Waikato River is provided by the comparison of field data to the remote sensing data, where the measured bearing angles of the outcropped ignimbrites located at Stations I and J were similar to the lineations seen in the multibeam data are similar (Fig. 4.13 and 4.19). A bearing of 33° was measured from ignimbrite outcrops at Location 11 to 10, only a 2° difference from the angle measured from the multibeam lineation, which was 31° . The similar angles suggest that these outcrops may be offset. Similar evidence is present for the area near the second bend; the bearing between the outcrops at Location 12 and 13 is 353° and the lineation found in the multibeam data is 357° , only a 4° difference. These angles are closer than the ones observed at Stubbs Road, but a margin of error can still exist depending on erosion of the material over time and the position of the outcrop not being exactly on the contact in some locations. Multibeam and seismic data also shows evidence for knickpoints as seen by the change in gradient both on the seismic data and the depressions on the multibeam data (Fig. 4.19 and 4.20). It can be interpreted from the multibeam images that the downstream section is either made of a softer, more erodible material compared to the upriver section, or if faulting is occurring that there is instead a change in lithology. Change in lithology seems more likely given the sharp difference from the upriver section to the downriver section. Further indication for a change in material and faulting can be seen in the

discontinuities in the seismic data and in some locations density differences from south to north of the transects (Fig. 4.20)

Outcrops found along the west and southern banks of the Waikato River show a change in lithology from east to west with younger material found along the large terrace at the first bend and older material in the ridge. Between these two outcrops on the large terrace was a landslide deposit that at some time had a period of reworking as indicated by the grading and lamination structures. It is possible that such changes in lithology are due to normal fluvial geomorphic process where young sediment is deposited along fluvial terraces as it weaves its way around topography composed of strong and older material. However, the observed change in material along the cliffs down river accompanied by an outcrop with possible offset bedding indicates that perhaps faulting is present, but without the location of exact contacts or better exposures confirmation cannot be given. Faulting does seem more likely due to the offset of ignimbrite outcrops, the alternating ignimbrite-sedimentary deposits at similar heights along the river, the possibly offset bedding, and the geomorphic signatures of aggradation and degradation coupled with the knowledge that fault zones have been found in similar ridges throughout the Hamilton Basin (Moon and de Lange, 2017; Spinardi et al., 2017; Campbell, 2017).

5.6 Day's Park, Braithwaite Park, and Horotiu

Geomorphological patterns observed at Day's Park and Braithwaite Park are similar to the ones observed at Stubbs Road and Hammond Park indicating that River Bends 7 to 10 are being influenced by the presence of a fault zone that is also creating the large NE oriented linear ridges in the area. However, what is different about this specific field area is that Ridge 2 does not propagate across the river like Ridge 1, instead it maintains a similar orientations to Ridges 4 to 7, and 9 with a possible connection through Ridge 8, indicating that this fault zone is splaying (Fig. 5.4). As presented in Sections 5.4 and 5.5 the Waikato River shows offset terraces, avulsed river channels, and an alternating pattern of aggradational and degradational areas with each transition point occurring along one of the major river bends, all signatures of tectonic influences on the Waikato River. What is unique to Day's Park and Braithwaite Park however is the presence of several drainage systems, D3a-D6, located on both sides of the river and each containing either a rectangular pattern or drainage capture in a perpendicular direction. These observations coupled with the confirmation of two faulted zones located in Rotouna and Kay Road is further indication of tectonic influences (Fig. 4.21A and 5.4).

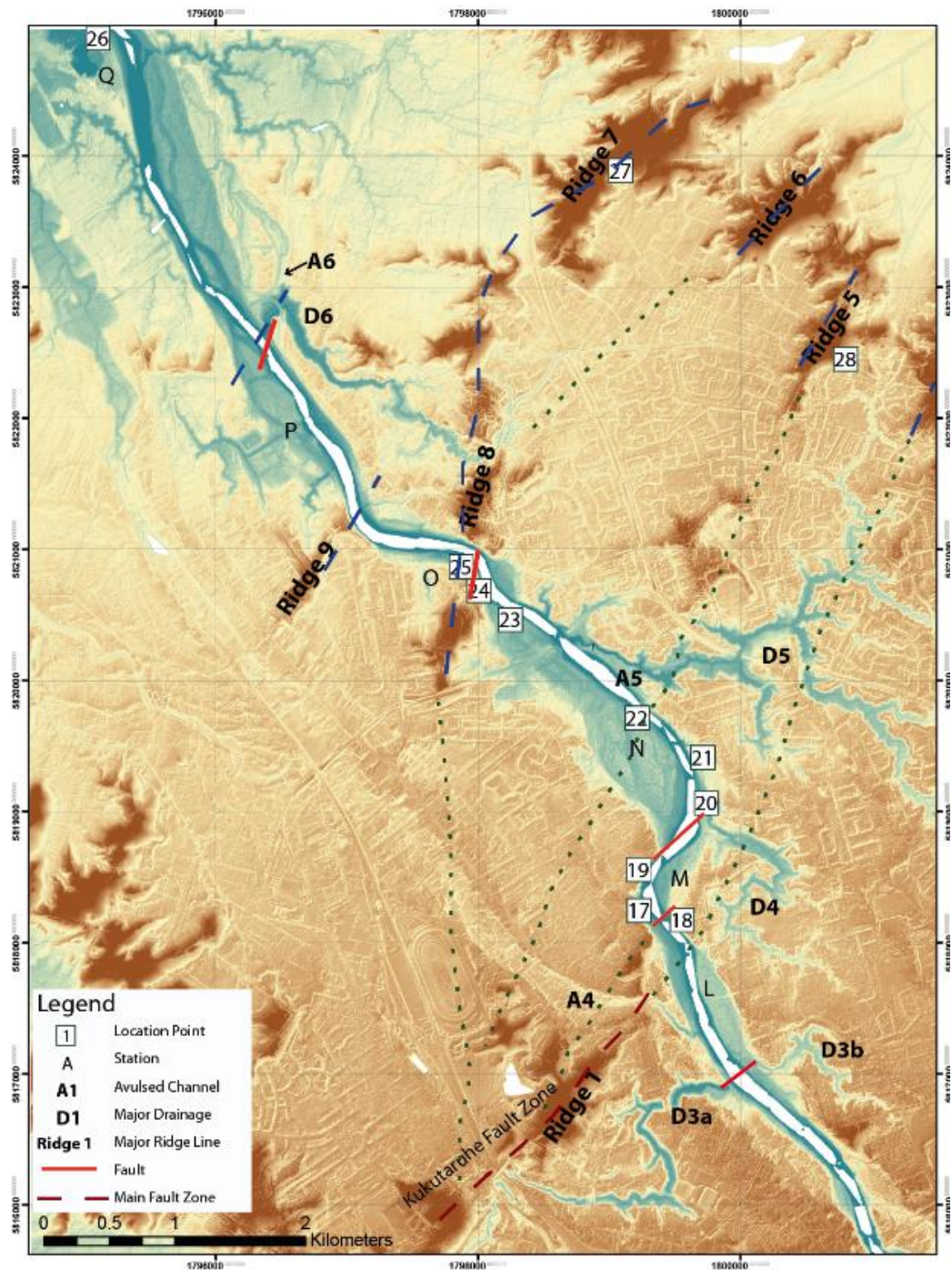

Figure 5.4. Geomorphic map of the area from Day's Park to Horotiu showing faults lines, both inferred and exposed, marked as the small red lines in relation to the location of the proposed Kukutaruhe Fault Zone. Secondary Fault zones are indicated by dashed blue lines, and proposed splays linking the secondary fault zones to the main fault zone are indicated by the dotted green lines.

The orientation of the Waikato River changes from NW to NE at Station M, creating a sharp orthogonal bend of approximately 98° similar to Stubbs Road and Hammond Park (Table 4.1). The bend at Station M occurs in the same location where Ridge 2 meets the Waikato River. A similar pattern is also observed at Station O where Ridges 8 and 9 intersect the

Waikato River creating bend angles of 115° and 110°. The coincidence of the major orthogonal bends in the river occurring in conjunction with these ridges suggests the ridges may be influencing the Waikato River's path (Fig. 4.21A). Ridge 2 located near Day's Park is a significant topographic and geomorphic feature that appears to originate near the Waipa Fault. It has been established that fault zones exist nearby in the smaller ridges, Ridge lines 5 and 7, which are both located near Ridge 2 and have similar orientations to one another (Campbell, 2017; Moon and de Lange, 2017). The similarity of these ridge lines and their proximity to one another are interpreted as an indication that these other small ridge lines can either be splays from a main fault or part of a larger fault zone. But before rushing to conclusions we must first consider other evidence, as discussed below.

The LiDAR data again shows a pattern of alternating aggradational /degradational zones along the Waikato River in this specific field zone. The first section of aggradation occurs from near Riverview Terrace to Awatere Avenue, marked by Station L, as indicated by the alternating wide fluvial terraces observed on either side of the Waikato River (Fig. 4.21A). A transition from aggradation to degradation is marked by the constriction of the Waikato River between Stations L and M just before Bend 7 at Day's Park. Aggradational signals are repeated again at Station N, but this geomorphology is dominated more by an extensive single terrace rather than paired or wide alternating terraces. The aggradational area is then choked off at Station O and is followed by the entrenchment, indicating a transition to degradational processes. Similar to Stubbs Road and Hammond Park, large extensive fluvial terracing followed by a point of constriction can be interpreted as the Waikato River being blocked or slowed by an obstacle in its path. If these changes from aggradation to degradation were caused by normal fluvial process along the Waikato River with help from the Taupo break out flood, directional changes of the Waikato River path would be marked by more abandoned river bars left behind when the river transitioned from a braided system to entrenchment. However, large number of such bars are not present.

Field survey data shows a possible offset of terraces near and along Station M, similar to Stubbs Road and Hammond Park. Steep sections at this location are composed of an older geological unit, in this case the Walton Subgroup, from the river level and up. On the Eastern side directly across the river and at similar levels Hinuera Formation is present (Fig. 4.21). However, based on this field evidence alone arguments can be made that the offset could either be due to the regular fluvial processes as the Waikato River was becoming entrenched, or tectonics. Unfortunately, no 3D multibeam images were available for this exact area nor were seismic survey data, so offset bearing could not be compared. However, data was available for the area near Station N. Comparison of the seismic data

to that of the multibeam data throughout Station N does not show any obvious lineations present in the multibeam image. However, the seismic data shows discontinuities and change in densities of material from south to north with these changes occurring at or near these discontinuities, indicating that a fault is present and could be causing these differences. No change in material was present in the field along the western Bank at Station N, and there is no data available for the area across the river so comparisons cannot be made. However, the possibility for a fault is present and more research in this area needs to be done to confirm whether or not this is the case.

Similar limitations exist for the bends at Station O. Limited field outcrops and lack of 3D multibeam images along the eastern bank of the Waikato River makes it difficult to determine if an offset these particular bends. However, seismic images were available and showed a change in density of the materials along the river bend from south to north, as seen by a single large dark area appearing in the south and up to four in the north. At the area where this transition occurs there is both a discontinuity indicating the presence of a fault and a possible change in lithology (Fig. 4.21B and 5.4).

Multibeam images were available between Stations P and Q and show strong lineations and either changes in geology or harder indurated material in these locations. Field information was limited due to lack of exposures, but it appears that near Station Q the material present is some type of reworked ignimbrite, possibly Walton Subgroup as indicated by the coarse clay material mixed with glass, and other volcanoclastic based material seen both in the thin sections and SEM photos. There is uncertainty regarding specifically what formation this outcrop is, either Walton Subgroup or ignimbrite, but either way it indicates that an outcrop of older geology is indeed present along this area. Having an older material present in a low lying area where not far down the river is Hinuera Formation shows a shift in the geology that was either caused by fluvial processes, or tectonic activity.

The surrounding drainages within the Day's Park and Braithwaite Park area should also be considered as evidence of tectonic geomorphology. Beginning in the southern section of the area at D3a and b, it is interesting to see a set of drainages not only aligned with Ridge 2, but also each other, though the Ridge 2 does not appear to directly continue across the river on the eastern side (Fig. 4.21A). It is also interesting to see that both D3a and b have rectangular patterns to them with their change of direction occurring along a similar axis. The same is observed at D4, Donny Park, but the axis in which these rectangular bends occur are both aligned with Ridge 2 and the location where the Waikato River shifts from an aggradational system to a degradational system (Fig. 4.21A). Rectangular drainage

patterns are often associated with joints, discontinuities, and faults within the area, indicating that a fault or fracture in the geology is present in this area and may be associated with Ridge 2 (Howard, 1967; Schumm et al., 2000; Burbank and Anderson, 2012). Along Ridge 2 on the western side of Station L and within the same alignment as D4's bend axis is the inlet for the avulsed Waikato River channel, A4 (Fig. 4.21A). Observationally, it is quite uncommon to have all these geomorphic features to be occurring together in the same region and alignment. It is even more suspicious to also have these features occurring within the same location where field results showed a possible offset on geological outcrops (Fig. 4.21B). It is possible that these changes could just be occurring due to differences in the underlying geology and the river is just taking advantages of these changes and weakness, but considering the geomorphic patterns, field data, and the seismic data taken further down the river there is an indication that the Waikato River is being influenced by tectonics at Day's Park. There is also evidence that what is occurring at Day's Park may be recent given the avulsed channel A4 that has been identified by McCraw (2011) as a paleochannel of the Waikato (Fig. 4.21A). Further evidence can be seen in drainages D5 and D6 along the eastern bank near Station N and P (Fig. 4.1). D5 possesses both a rectangular drainage pattern through its catchment, and drainage beheadment as seen by the NW oriented drainages being crosscut and flowing to a NE oriented tributary. At the outlet of the D5 is an abandoned outlet, A5, which indicates the tributary was flowing out to the modern Waikato River near Location 22 before something caused it to shift NW and output near Location 23 instead. The change in outlet location and the capture of NW drainages by the NE tributary are both similarities to D1 at Hammond Park, where D1 beheads other drainages from a NW direction to a dominant NE direction. Located just north of D5 is a system of NE oriented ridge lines, Ridges 5, 6, and 7, where two fault zones were uncovered by Campbell (2017) and Moon and de Lange (2017), giving more indication that faults may be having an influence in the area. Lastly, D6, located at near Station P, also shows rectangular patterns and abandoned channels that are present in recent geological material. The beginning of D6 occurs between the north sections of Ridge 8. Like the other drainages in this area, D6 takes four rectangular bends before it connects to the Waikato River. Similar to D5 and D1, this drainage takes a sharp bend near its outlet, causing it to drain into the Waikato toward the SW rather than continuing NW like it normally did as indicated by the abandoned channel A6 (Fig. 4.21A). The first series of rectangular bends taken by D6 are aligned with Ridges 7 and 9. It has been established that a fault zone is present at Ridge 7 (Campbell; 2017), indicating that the diversion and change along the drainage's path is likely due to the presence of this fault zone. However, this fault zone was concluded to be inactive which brings up the debate of

whether the drainage pattern of D6 is either the result of exploitation of the pre-existing discontinuities and/or changes in the lithology, or if there is still an active system influencing it. It is important to point out that pathways chosen by surface water can be biased toward weak structural features and can still be affected by them whether the features are the cause of active or non-active deformation. It is for this reason that more information will be needed to determine if the faults within the Hamilton Basin are indeed active or not.

5.7 The Hamilton Basin Fault Zones

Reviewing the information gathered from the LiDAR, field survey, multibeam images, and seismic survey, geomorphic patterns suggestive of fault structural controls on the landform development can be observed along the Waikato River from north Tamahere to Horotiu. These geomorphic patterns occur at each major rectangular bend in the river and are accompanied by crossing of NE to NNE ridge lines that extend from the west near the Waipa Fault into the Hamilton Basin (Fig. 5.5). Preliminary evaluations made through remote sensing and field investigations indicate that the major NE and NNE trending ridge lines of the basin are linked to major fault zones within the Hamilton Basin, causing the Waikato River to be influenced by this activity (Fig. 5.5). From this investigation, coupled with investigations by Campbell (2017) and Moon and de Lange (2017), two major fault zones have been identified within Hamilton Basin. The Kukutaruhe Fault Zone runs through the Kay Rd and Rototuna area and includes the identified and previously investigated faults zones along the Hamilton Bypass and residential development. The Te Tatua o Wairere Fault Zone encompasses the ridge line along Stubbs Road and Hammond Park, extending to the University of Waikato (Fig. 5.5).

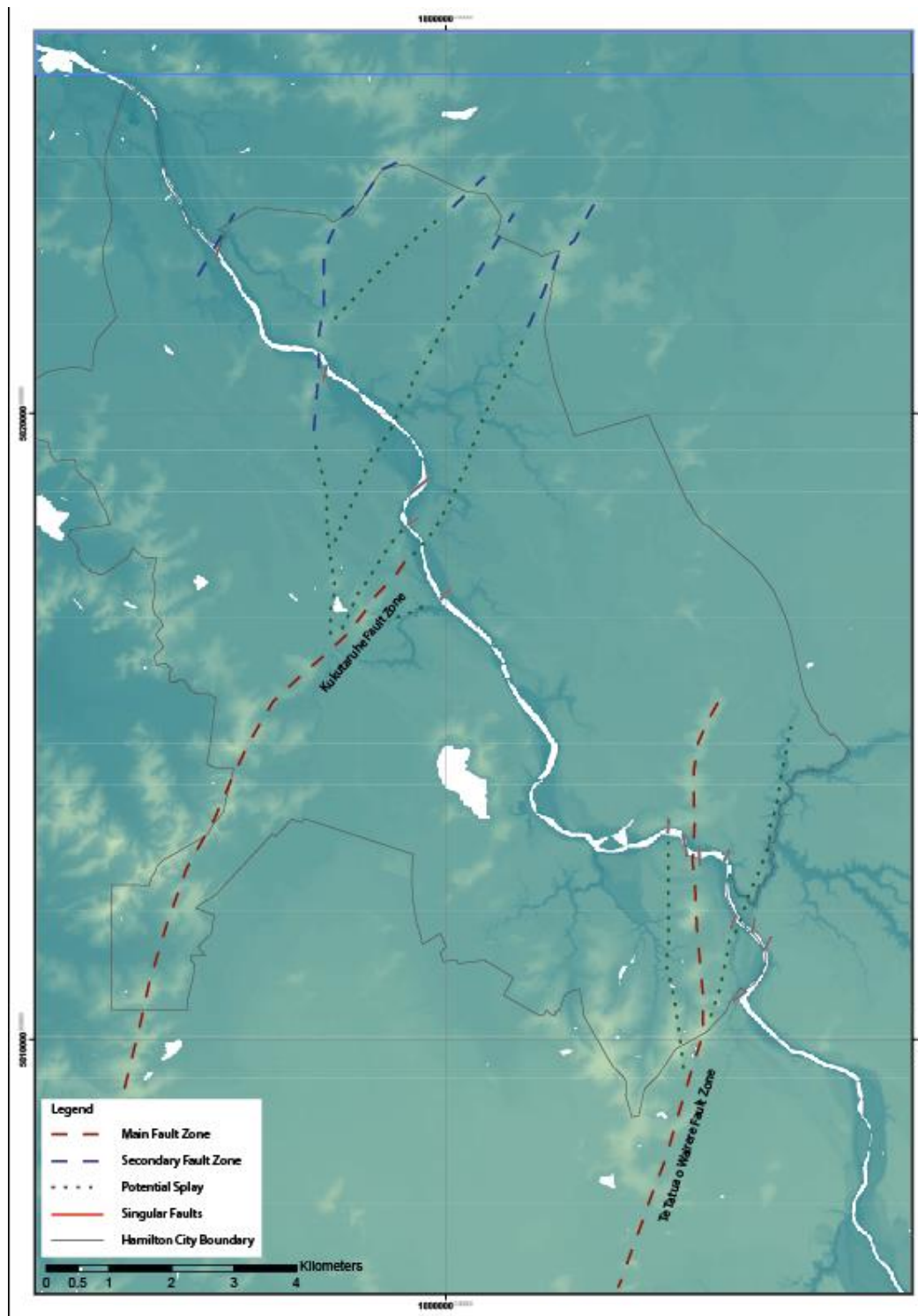

Figure 5.5. Map showing the location of the proposed Kukutaruhe and the Te Tatu o Wairere Fault zones based on the geomorphic and field evidence from this study. Secondary fault zone systems are indicated by the blue dashed lines and proposed connecting splays by the green dotted lines. Fault lines either found or inferred during this study are shown by the small red lines along the Waikato River.

As discussed in Section 2.6.3 faults lines progress in failures from their tips, and as a result can form splays (Reaches and Lockner, 1994; Feng and Harrison, 2002; Fossen, 2010). Unlike the Hammond Park region, Ridge 2 at Day’s Park does not cross the river, but we

see many smaller ridgelines across the river with the same alignment. It is possible that at this particular location the fault zone is splaying, creating these other fault lines. It is also possible that though the fault zone discovered at Kay Road is inactive, it could have been an abandoned splay of the larger system as it has progressed (Gudmundsson et al., 2010; Fossen, 2010). Possible evidence for this is the avulsed river channel A4 near Day's Park. The channel maintained a NW direction containing only one bend when it first cut through Ridge 2, but now the Waikato River moves a completely different direction with lots of bends causing it to switch direction temporarily before returning to its overall NW orientation. It could be that if Ridge 2 is indeed a fault zone that it could be the main active zone accommodating for the acting stresses. If it is still developing the area where failure is likely to occur would be at its tip, which based on the geomorphology is located at Day's Park near Chartwell (Reaches and Lockner, 1994; Feng and Harrison, 2002; Fossen, 2010).

Considering all the presented information, including previous studies of the surrounding larger structural geological features such as the Waipa and Taupiri Faults together with the Junction Magnetic Anomaly (JMA) and basin depression with the Hamilton region, there is evidence that these larger structural features are influencing the formation of normal extensional faults, possibly in the form of a domino listric fault system, within the Hamilton Basin (Odinsen et al., 2000). Review of information regarding the JMA and the Waipa fault shows that dextral slip was occurring along the Waipa fault into the Paleogene. However, the Waipa Fault stops in the north just past Hamilton and to the east are two active normal faults, the Wairoa Fault and the Kerepehi Fault, and one inactive fault, Maungaroa Fault (Fig. 5.6). When viewing the Waipa Fault to the Maungaroa Fault and Wairoa Fault it can be observed they have similar orientations and that the offset and space between these two faults resembles that of a relay ramp (Fig. 5.6). Between these two fault lines is the Taupiri Fault proposed by Kirk (1991), which is indicated to have a normal movement with the down dropped section containing the Hamilton Basin. Given the position and movement of these faults it can be interpreted that the Taupiri Fault is the breaching failure between the Waipa Fault and the Wairoa North Fault (Fig. 5.6). There is evidence that strike-slip movement was occurring along the Waipa Fault. If the movement of this fault has since transferred over to the Maungaroa and Wairoa Faults, or even partly the Kerepehi Fault, then the Taupiri Fault would have acted as the propagated failure between these two structures as stresses and movement shifted to its current location as seen by the active fault lines in the east. Not much is known about the Maungaroa and Wairoa Faults except that the Wairoa is an active west ward dipping normal fault (Wise et al., 2003). It is proposed that as this propagation was occurring, and in some ways is still actively

deforming, that the Taupiri Fault and the faults contained within the Hamilton Basin formed as a result to help accommodate for the change in space as stress and failure was shifting and propagation from the Waipa Fault to the east (Fig. 5.5 and 5.6). The larger structure that is interpreted to be forming in the Hamilton Basin is a transtensional pull apart basin that is forming as an accommodation zone between the non-active Waipa Fault, and the active normal faulting Taupiri, Wairoa, and Kerepihi Faults (Fig.5.6).

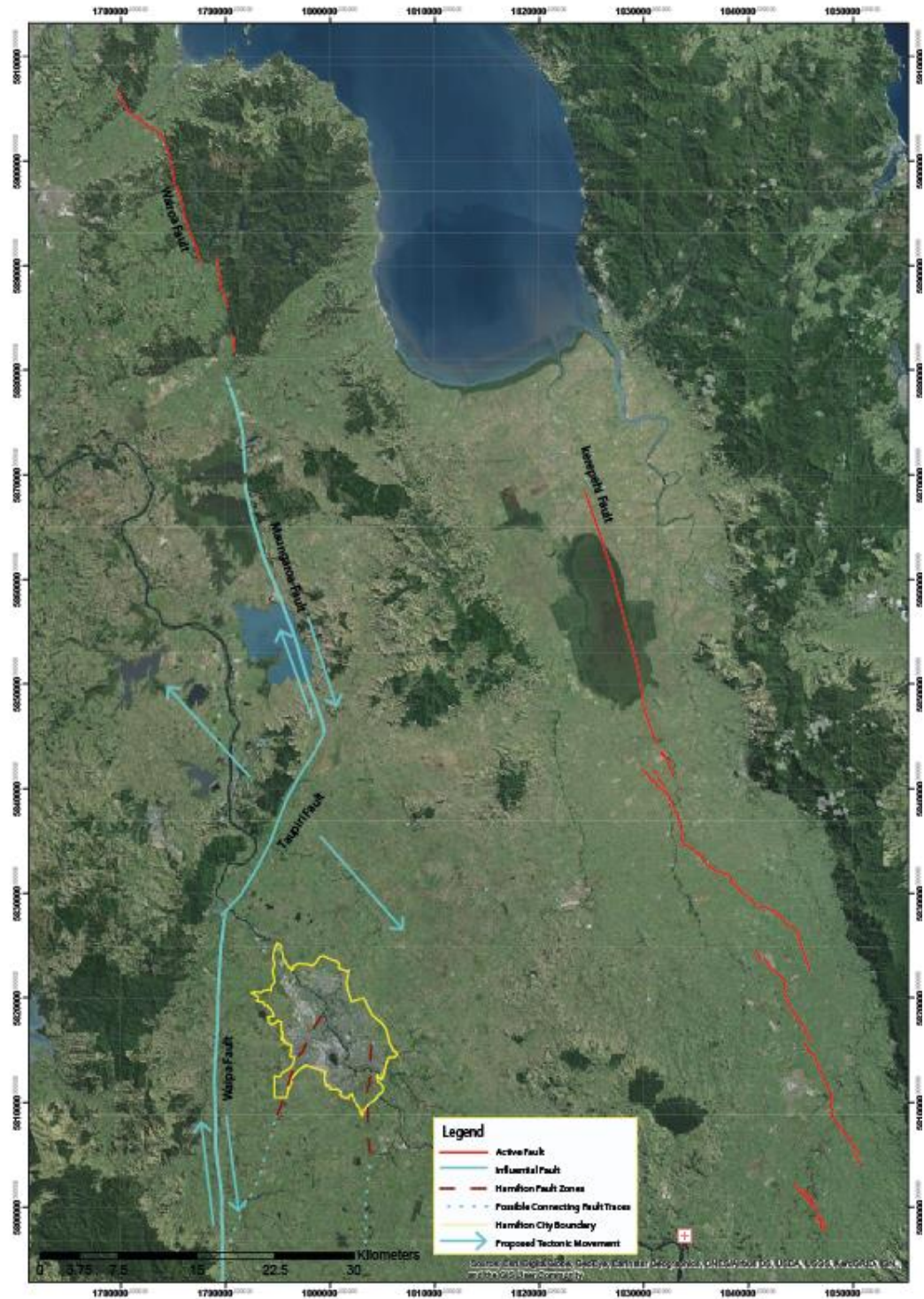

Figure 5.6. Map of proposed tectonic hypothesis for how and why the fault zones in Hamilton are forming. The influential faults, the Waipā and the Maungaroa Fault indicated by the light blue, are offset. The Taupiri Fault, also indicated by the light blue line, is the breached failure linking the two faults. Note that though the active Wairoa fault is not highlight blue, it has a similar orientation to the Maungaroa Fault, indicating that it too could be contributing to the formation of fault zones in Hamilton.

5.8 Concluding Remarks and Future Research

The principal aim of this study was to examine the Hamilton Basin's geomorphology for possible tectonic influences and to use the information to build a hypothesis of how and why these structures are present. Due to poorly consolidated nature of the material found in the Hamilton Basin together with the heavy urbanization and vegetation growth, outcrops containing structural geologic features indicative to faulting are difficult to find. As a result of these limitations standard geologic mapping practices were used in conjunction with remote sensing in order to examine the basin for tectonic geomorphological features. What was discovered is that the major orthogonal bends along the Waikato River show a relationship and pattern to other geomorphology features such as fluvial terrace, alternating aggradational degradational zones separated by sudden points of constriction, abandoned river channels, rectangular drainage patterns, beheaded drainages, and linear ridges. When comparing geomorphological data from LiDAR imaging with the result from field survey, 14 faults were found that seem to be related to a large system. It is proposed that at least two major fault zones named the Kukutaruhe and the Te Tatua o Wairere Fault Zones are present along the southern and middle section of the Hamilton Basin. Evidence from the tectonic geomorphology features, field data, and remote sensing data indicate that these zones are normal fault faults with a possible listric structure. Geomorphic signatures in the area from the Hamilton Garden to Days Park are similar to those found at Day's Park and Hammond Park, indicating that a possible third fault zone could be present, and cutting through central Hamilton. However, more investigation is needed to determine if the fault zone is there given data was limited and inconclusive. Additionally their structures located near the Melville, Fitzroy, and Glenview area that indicated the presence of another fault zone, possibly a splay, but more investigation of this area is needed.

The Kukutaruhe and the Te Tatua o Wairere Fault zones seem to originate from the western boundary of the Hamilton Basin, possibly near the Waipa Fault and extend in to the centre of the city of Hamilton. Though Campbell (2017) investigated a secondary fault zone located near the Kukutaruhe Fault zone, and found it was not active, there is geomorphic evidence such as the avulsed river channels and outlets A1 to A6, indicating possible recent movement. However, more investigation is needed to be sure whether these systems are indeed active. It is proposed further field investigation be conducted in these locations during the summer and when water levels are low, in order to gain more exposure of outcrops. Examination of the geology during the construction of the Hamilton Bypass, and the Wairere Extension Bridge will also allow for better examination of the geology.

Additional investigation will also need to be conducted at Horotiu, Hamilton Gardens, Central Hamilton, and Day's Park areas in order to assess if these faults are active. Suggested future studies should involve examination of the sinuosity of the Waikato River, resistivity of the geology along tectonic geomorphic features, such as ridges. If possible, updated seismic reflection data or trenching would also help to determine activity and offset along these fault zones.

Review of information of the surrounding regional faults and the geophysical data of the region show that the Waipa fault has experienced dextral shearing resulting in the rotation of the Hakaramata Ranges from a pivotal axis point without disturbing the Junction Magnetic Anomaly. This rotation has resulted in the formation of a NE oriented normal fault called the Taupiri Fault which acts as the northern boundary of the Hamilton Basin. It is my hypothesis that the Taupiri Fault is acting as a breached relay ramp between the Waipa Fault in west and the Maungaroa and/or the Wairoa Fault in the east. Both the Waipa Fault and the Wairoa have a history of dextral slip occurring at some stage in their history. It is proposed that the Taupiri Fault and the fault zones found in the Hamilton Basin are the results of transtensional movement along a release bend between the Waipa, Maungaroa, and Wairoa Faults. It is also proposed that the fault zones in the Hamilton Basin have developed as a way to accommodate space between the major fault systems. However, to determine this hypothesis geophysical and structural geological examination will need to be conducted in the Hamilton Basin and along the Taupiri Fault.

REFERENCES

- Adams, C. J., Campbell, H. J., Graham, I. J., & Mortimer, N. (1998). Torlesse, Waipapa and Caples suspect terranes of New Zealand: integrated studies of their geological history in relation to neighbouring terranes. *Episodes*, 21, 235-240.
- Anderson, E. M. (1951). *The dynamics of faulting and dyke formation with applications to Britain* (2nd rev. ed.). Edinburgh: Oliver and Boyd.
- Burbank, D. W., & Anderson, R. S. (2011). *Tectonic geomorphology*. John Wiley & Sons.
- Ballance, (1988) The Huriwai Braidplain delta of New Zealand: A late Jurassic, coarse-grained, Volcanic-fed depositional system in a Gondwana Forearc basin, in Nemec, W., and Steel, R. J. (1988). *Fan deltas: Sedimentology and tectonic settings*. Glasgow: Blackie
- Ballance, P. F. (1993), The Paleo-Pacific, post-subduction, passive margin thermal relaxation sequence (Late Cretaceous-Paleogene) of the drifting New Zealand continent, in *South Pacific Sedimentary Basins*, edited by P. F. Ballance, pp. 93–110, Elsevier, Amsterdam, Netherlands.
- Ballance, P. F.; and Campbell, J. D. (1993) A murikihiku arc-related basin of New Zealand (Triassic-Jurassic) in *Balance South Pacific Sedimentary Basins*, in *South Pacific Sedimentary Basins*, edited by P. F. Ballance, pp. 22–33, Elsevier, Amsterdam
- Black, P. M., Clark, A. S. B. and Hawke, A. A. (1993), Diagenesis and very low-grade metamorphism of volcanoclastic sandstones from contrasting geodynamic environments, North Island, New Zealand: the Murikihiku and Waipapa terranes. *Journal of Metamorphic Geology*, 11: 429–435. doi:10.1111/j.1525-1314.1993.tb00159.x
- Black, P. M. (1994). The "Waipapa Terrane", North Island, New Zealand: Subdivision and correlation (MEMORIAL VOLUME TO THE LATE PROFESSOR TERUHIKO SAMESHIMA). *Geoscience Reports of Shizuoka University*, 20, 55-62.
- Boulton, S. J., & Whittaker, A. C. (2009). Quantifying the slip rates, spatial distribution and evolution of active normal faults from geomorphic analysis: Field examples from an oblique-extensional graben, southern Turkey. *Geomorphology*, 104(3), 299-316.
- Briggs, R. M., Gifford, M. G., Moyle, A. R., Taylor, S. R., Norman, M. D., Houghton, B. F., & Wilson, C. J. N. (1993). Geochemical zoning and eruptive mixing in ignimbrites from Mangakino volcano, Taupo Volcanic Zone, New Zealand. *Journal of volcanology and geothermal research*, 56(3), 175-203.
- Briggs, R. M., Middleton, M. P., & Nelson, C. S. (2004). Provenance history of a Late Triassic-Jurassic Gondwana margin forearc basin, Murikihiku Terrane, North Island, New Zealand: Petrographic and geochemical constraints. *New Zealand Journal of geology and geophysics*, 47(4), 589-602.

- Brink, M. (2012). *Emplacement processes of ignimbrites in the Ongatiti Valley, southeast Te Kuiti*.
- Butler, R. W. H. (1982). The terminology of structures in thrust belts. *Journal of Structural Geology*, 4(3), 239-245. doi:10.1016/0191-8141(82)90011-6
- Campbell, H. J., Mortimer, N., & Turnbull, I. M. (2003). Murihiku Supergroup, New Zealand: redefined. *Journal of the Royal Society of New Zealand*, 33(1), 85-95
- Campbell, B. R. (2017). *Hamilton's Hidden Hazard: The Characterisation and Mapping of Zones of Tectonic Deformation within the Hamilton Basin (In Progress)*. MSc thesis, The University of Waikato, Hamilton, New Zealand.
- Cannat, M., Fontaine, F., & Escartín, J. (2010). Serpentinization at slow-spreading ridges: Extent and associated hydrogen and methane fluxes. *Diversity of Hydrothermal Systems on Slow Spreading Ocean Ridge*. American Geophysical Union Geophysical Monograph, 188, 241-264.
- Cassidy, J., & Locke, C. A. (1987). Thin ophiolites of North Island, New Zealand. *Tectonophysics*, 139(3), 315-319.
- Cartwright, S. (2003). *Cenozoic geological evolution of the central eastern King Country Basin, North Island.*
- Coombs, D. S., Landis, C. A., Norris, R. J., Sinton, J. M., Borns, D. J., & Craw, D. (1976). The Dun Mountain Ophiolite Belt, New Zealand, its tectonic setting, constitution, and origin, with special reference to the southern portion. *American journal of science*, 276(5), 561-603.
- Davy, B. (1993). The bounty trough – Basement structure influences on sedimentary basin evolution, in *South Pacific Sedimentary Basins*, edited by P. F. Ballance, pp. 93–110, Elsevier, Amsterdam, Netherlands.
- de Lange, P. J., & Lowe, D. J. (1990). History of vertical displacement of Kerepehi Fault at Kopouatai bog, Hauraki Lowlands, New Zealand, since c. 10 700 years ago.
- Deschamps, F., Godard, M., Guillot, S., & Hattori, K. (2013). Geochemistry of subduction zone serpentinites: A review. *Lithos*, 178, 96-127
- Eccles, J. D., Cassidy, J., Locke, C. A., & Spörli, K. B. (2005). Aeromagnetic imaging of the Dun Mountain Ophiolite Belt in northern New Zealand: insight into the fine structure of a major SW Pacific terrane suture. *Journal of the Geological Society*, 162(4), 723-735.
- Edbrooke, S. W., Sykes, R., & Pocknall, D. T. (1994). *Geology of the Waikato coal measures, Waikato coal region, New Zealand (Vol. 6)*. Institute of Geological & Nuclear Sciences Limited.
- Edbrooke, S.W., Bregg, J. G., & Institute of Geological & Nuclear Sciences Limited. (2005) *Waikato. Lower Hutt, N.Z.: Institute of Geological & Nuclear Sciences*.
- Edbrooke, S.W. (compiler) (2005). *Geology of the Waikato area: scale 1:250,000*. Lower Hutt: Institute of Geological & Nuclear Sciences. Institute of Geological & Nuclear Sciences 1:250,000 geological map 4. 68 p. + 1 folded

map

- Edbrooke, S. W. (2005). *Geology of the Waikato Area*. Lower Hutt, N.Z: Institute of Geological & Nuclear Sciences
- Elliott, D. (1976). The motion of thrust sheets. *Journal of Geophysical Research*, 81, 949-963. doi: 10.1029/JB081i005p00949
- Evans, J. P., Forster, C. B., & Goddard, J. V. (1997). Permeability of fault-related rocks, and implications for hydraulic structure of fault zones. *Journal of Structural Geology*, 19(11), 1393-1404. doi:10.1016/S0191-8141(97)00057-6
- Fang, Z., & Harrison, J. P. (2002). Development of a local degradation approach to the modelling of brittle fracture in heterogeneous rocks. *International Journal of Rock Mechanics and Mining Sciences*, 39(4), 443-457. doi:10.1016/S1365-1609(02)00035-7
- Fleming, C. A. & Kear, D. (1960). The Upper Jurassic sequence at Kawhia, New Zealand, with reference to the ages of some Tethyan guide fossils (pp. 264-9). Det Berlingske Bogtrykkeri.
- Fleming, C. A., & Kear, D. (1960). The Jurassic Sequence at Kawhia Harbour, New Zealand:(Kawhia Sheet, N73) (No. 67). New Zealand Department of Scientific and Industrial Research.
- Fossen, H. (2010). *Structural geology*. Cambridge; New York: Cambridge University Press.
- FrOG Tech, 2011. Waikato Structural GIS and SEEBASE Project: Phase 1 November 2010, FrOG Tech Project Code CWE701 and Phase 2 November 2011, FrOG Tech Project Code CWE703. Ministry of Economic Development New Zealand Unpublished Petroleum Report PR 4432
- Fryirs, K. A., & Brierley, G. J. (2012). *Geomorphic analysis of river systems: an approach to reading the landscape*. John Wiley & Sons.
- Furlong, K. P., & Kamp, P. J. (2009). The lithospheric geodynamics of plate boundary transpression in New Zealand: Initiating and emplacing subduction along the Hikurangi margin, and the tectonic evolution of the Alpine Fault system. *Tectonophysics*, 474(3), 449-462. doi:10.1016/j.tecto.2009.04.023
- Gibbs, A. D. (1983). Balanced cross-section construction from seismic sections in areas of extensional tectonics. *Journal of Structural Geology*, 5(2), 153-160. doi:10.1016/0191-8141(83)90040-8
- Gudmundsson, A., Simmenes, T. H., Larsen, B., & Philipp, S. L. (2010). Effects of internal structure and local stresses on fracture propagation, deflection, and arrest in fault zones. *Journal of Structural Geology*, 32(11), 1643-1655. doi:10.1016/j.jsg.2009.08.013
- Healy, D., Sibson, R. H., Shipton, Z., & Butler R. (2012). Stress, faulting, fracturing and seismicity: the legacy of Ernest Masson Anderson. Geological Society, London, Special Publications, v.367: 1-6; doi: 10.1144/SP367.1
- Henza, A. A., Withjack, M. O., & Schlische, R. W. (2010). Normal-fault development during two phases of non-coaxial extension: An experimental study. *Journal*

- of Structural Geology, 32(11), 1656-1667. doi:10.1016/j.jsg.2009.07.007
- Hochstein, M. P., Tearney, K., Rawson, S., Davey, F. J., Davidge, S., Henrys, S., & Backshall, D. (1986). Structure of the Hauraki Rift (New Zealand). *Royal Society of New Zealand Bulletin*, 24, 333-348.
- Hochstein, M. P., & Ballance, P. F. (1993). Hauraki Rift: a young, active, intra-continental rift in a back-arc setting. *South Pacific Sedimentary Basins, Sedimentary Basins of the World*, 2, 295-305.
- Houghton, B., & Cuthbertson, A. (1989). Sheet T14 BD—Kaimai. Geological map of New Zealand, 1(50), 000.
- Howard, A. D. (1967). Drainage analysis in geologic interpretation: a summation. *AAPG bulletin*, 51(11), 2246-2259.
- Huggett, R. (2007). *Fundamentals of geomorphology*. Routledge
- Hume, T. M., Sherwood, A. M., & Nelson, C. S. (1975). Alluvial sedimentology of the upper pleistocene hinuera formation, hamilton basin, New Zealand. *Journal of the Royal Society of New Zealand*, 5(4), 421-462.
- Hunt, T. (1978). Stokes magnetic anomaly system. *New Zealand journal of geology and geophysics*, 21(5), 595-606.
- Jackson, J., & McKenzie, D. (1983). The geometrical evolution of normal fault systems. *Journal of Structural Geology*, 5(5), 471-482. doi:10.1016/0191-8141(83)90053-6
- Jain, V., & Sinha, R. (2005). Response of active tectonics on the alluvial Baghmata River, Himalayan foreland basin, eastern India. *Geomorphology*, 70(3), 339-356.
- Jiao, R., Seward, D., Little, T. A., & Kohn, B. P. (2014). Thermal history and exhumation of basement rocks from Mesozoic to Cenozoic subduction cycles, central North Island, New Zealand. *Tectonics*, 33(10), 1920-1935.
- Kamp, P. J. J. (2000). Thermochronology of the Torlesse accretionary complex, Wellington region, New Zealand. *J. Geophys. Res.*, 105(B8), 19,253–19,272, doi:10.1029/2000JB900163.
- Kamp, P. J. J., & Lowe, D. J. (1981). Quaternary stratigraphy, landscape, and soils of the Hamilton Basin. In R. M. Briggs (Ed.), *Geological Society of New Zealand Miscellaneous Publication, Vol. 29B (Tour Guides)* (pp. 14–28). Hamilton, New Zealand: University of Waikato
- Kim, Y., & Sanderson, D. J. (2006). Structural similarity and variety at the tips in a wide range of strike–slip faults: A review. *Terra Nova*, 18(5), 330-344. doi:10.1111/j.1365-3121.2006.00697.x
- Kear, D. (1971). Basement rock facies—northern North Island. *New Zealand journal of geology and geophysics*, 14(2), 275-283.
- Kear, D., & Mortimer, N. (2003). Waipa Supergroup, New Zealand: a proposal. *Journal of the Royal Society of New Zealand*, 33(1), 149-163.
- Kear, D., & Schofield, J. C. (1964). Stratigraphic Summary, Ngaruawahia Subdivision. *New Zealand journal of geology and geophysics*, 7(4), 892-893.

- Kear, D., Schofield, J. C., & Couper, R. A. (1978). Geology of the Ngaruawahia subdivision (No. 88). New Zealand, Dept. of Scientific and Industrial Research.
- King, P. R. (2000). Tectonic reconstructions of New Zealand: 40 Ma to the present. *New Zealand Journal of Geology and Geophysics*, 43(4), 611-638.
- Kirk, P. A. (1991). Waipa Fault and the tectonic rotation of Hakarimata–Taupiri Block. *Record—New Zealand Geological Survey*, 43, 81-84.
- Laird, M. G. (1993). Cretaceous continental rifts: New Zealand region. *South Pacific sedimentary basins. Sedimentary basins of the world*, 2, 37-49. Elsevier, Amsterdam
- Laird, M. G., & Bradshaw, J. D. (2004). The break-up of a long-term relationship: the Cretaceous separation of New Zealand from Gondwana. *Gondwana Research*, 7(1), 273-286.
- Lowe, D. J. (2000). Upbuilding pedogenesis in multisequal tephra-derived soils in the Waikato region.
- Lowe, D. J. (2010). Introduction to the landscapes and soils of the Hamilton Basin.
- Lowe, D. J., Tippett, J. M., Kamp, P. J., Liddell, I. J., Briggs, R. M., & Horrocks, J. L. (2001). Ages on weathered Plio-Pleistocene tephra sequences, western north Island, New Zealand.
- Lowrie, W. (2007). *Fundamentals of Geophysics* (2nd ed.). Cambridge: Cambridge University Press.
- Manville, V. (2002). Sedimentary and geomorphic responses to ignimbrite emplacement: readjustment of the Waikato River after the AD 181 Taupo eruption, New Zealand. *The Journal of Geology*, 110(5), 519-541.
- McCraw, J. D. (2011). The wandering river: landforms and geological history of the Hamilton Basin. Geoscience Society of New Zealand.
- Mortimer, N. (2004). New Zealand's geological foundations. *Gondwana Research*, 7(1), 261-272.
- Moon, V. G., & de Lange, W. P. (2017). Final Report on EQC Potential shallow seismic sources in the Hamilton Basin. Retrieved September 6, from.
- Moyle, A. (1989). *Volcanic geology and geochemistry of the rocky hill ignimbrite, upper Waipa Valley*.
- Nash, D. (2013). 5.10 Tectonic Geomorphology of Normal Fault Scarps. In *Treatise on Geomorphology* (pp. 234-249).
- Odinsen, T., Christiansson, P., Gabrielsen, R. H., Faleide, J. I., & Berge, A. M. (2000). The geometries and deep structure of the northern North Sea rift system. *Geological Society, London, Special Publications*, 167(1), 41-57.
- O'brien, J. P., & Rodgers, K. A. (1973). Alpine-type serpentinites from the Auckland Province—I. The Wairere serpentinite. *Journal of the Royal Society of New Zealand*, 3(2), 169-190.
- Ouchi, S. (1985). Response of alluvial rivers to slow active tectonic movement. *Geological Society of America Bulletin*, 96(4), 504-515.

- Persaud, M., Villamor, P., Berryman, K. R., Ries, W., Cousins, J., Litchfield, N., & Alloway, B. V. (2016). The Kerepehi Fault, Hauraki Rift, North Island, New Zealand: active fault characterisation and hazard. *New Zealand Journal of Geology and Geophysics*, 59(1), 117-135.
- Purser, B. H. (1961). Geology of the Port Waikato region (Onewhero sheet N51) (No. 67-69). New Zealand Dept. of Scientific and Industrial Research.
- Peacock, D. C. P. (2002). Propagation, interaction and linkage in normal fault systems. *Earth Science Reviews*, 58(1), 121-142. doi:10.1016/S0012-8252(01)00085-X
- Peacock, D. C. P., & Sanderson, D. J. (1991). Displacements, segment linkage and relay ramps in normal fault zones. *Journal of Structural Geology*, 13(6), 721-733. doi:10.1016/0191-8141(91)90033-F
- Reches Z, Lockner DA (1994) Nucleation and growth of faults in brittle rocks. *Journal of Geophysical Research* 99(B9):18159–18173. doi:10.1029/94JB00115
- Selby, M. J., & Lowe, D. J. (1992). The middle Waikato Basin and hills. In: *Landforms of New Zealand: Second Edition: The University of Waikato.*
- Schumm, S. A., Schumm, S. A., Dumont, J. F., & Holbrook, J. M. (2002). *Active tectonics and alluvial rivers*. Cambridge University Press.
- Simpson, R. W. (1997). Quantifying anderson's fault types. *Journal of Geophysical Research: Solid Earth*, 102(B8), 17909-17919. doi:10.1029/97JB01274
- Spinardi, F., Campbell, B., Moon, D. V., Pittari, A., Fox, B. R. S., & de Lange, W. P. (2017 (In Press)). Unravelling Fault Structures of the Hamilton Basin. Proc. 20th NZGS Geotechnical Symposium.
- Spörli, K. B. (1978). Mesozoic tectonics, north island, New Zealand. *GSA Bulletin*, 89(3), 415-425. doi:10.1130/0016-7606(1978)89<415:MTNINZ>2.0.CO;2
- Spörli, K. B., Aita, Y., & Gibson, G. W. (1989). Juxtaposition of Tethyan and non-Tethyan Mesozoic radiolarian faunas in melanges, Waipapa terrane, North Island, New Zealand. *Geology*, 17(8), 753-756.
- Stagpoole, V., & Nicol, A. (2008). Regional structure and kinematic history of a large subduction back thrust: Taranaki Fault, New Zealand. *Journal of Geophysical Research: Solid Earth*, 113(B1).
- Thatcher, W., & Hill, D. P. (1991). Fault orientations in extensional and conjugate strike-slip environments and their implications. *Geology*, 19(11), 1116-1120.
- Tulloch, A.J., Ramezani, J., Mortimer, N., Mortensen, J., van den Bogaard, P., Maas, R., (2009). Cretaceous felsic volcanism in New Zealand and Lord Howe Rise (Zealandia) as a precursor to final Gondwana break-up. In: Ring, U., Wernicke, B. (eds.), *Geological Society of London Special Publications* 321, pp. 89–118.
- Wilson, C. J. N. (1986). Reconnaissance stratigraphy and volcanology of ignimbrites from Mangakino volcano. *Late Cenozoic volcanism in New Zealand. Royal Society of New Zealand Bulletin*, 23, 179-193.
- Wernicke, B., & Axen, G. J. (1988). On the role of isostasy in the evolution of normal fault systems. *Geology*, 16(9), 848-851. doi:10.1130/0091-7613(1988)016<0848:OTROII>2.3.CO;2
- Wernicke, B., & Burchfiel, B. C. (1982). Modes of extensional tectonics. *Journal of*

Structural Geology, 4(2), 105-115. doi:10.1016/0191-8141(82)90021-9

Wise, D. J., Cassidy, J., & Locke, C. A. (2003). Geophysical imaging of the quaternary Wairoa North Fault, New Zealand: a case study. *Journal of Applied Geophysics*, 53(1), 1-16.

Wood, A. (2006). *Morphodynamic channel and stability of the Waikato river : Karapiro to Ngaruawahia reach*. 2006.

APPENDIX I

Sample No.	Lithology Type	Examination Observations
R1S7A	sediment	Moderately sorted with 45% lithic or pumice. Sorting is less at the bottom of the slide and more sorted in the iron stained band
R1S7B	sediment	moderately sorted with small angular-subangular minerals in fine matrix; quartz, plagioclase, glass, and fibrous pumices are present; toward bottom lithic are sub rounded and mineral sub round to sub-angular
R1S7C	ignimbrite	Uniform segment of rock with subangular to subrounded minerals and rounded to subround lithics; small fragments of pumice or lithics makes 20% sample and 40% is glass, minerals are quartz and plagioclase and seem almost imbricated or flattened in one section.
R1S8sed A	reworked ignimbrite	Lots of glass, pumice, plagioclase, and glass; Well sorted with subrounded lithics and sub round to sub angular minerals; small amount of pumice fragments and glass; clast supported; lithic fragments look like older ignimbrite pieces
R1S8Bup TOP	ignimbrite	light fines with coarse upper parts consisting of lots of glass and scatterings of feldspar and quartz; material is poorly sorted
R1S8Blo w2	ignimbrite	lots of glass with small amounts of angular minerals; poorly sorted with section containing suspended pumice in ash matrix; minerals are plagioclase
R1S8Blo w3	ignimbrite	massive glass with scatters of plagioclase; minerals are angular and sharp; pumice fragments also present
R1S8D	ignimbrite	moderately sorted subround to round lithics and angular to subangular minerals, mostly plagioclase; clasts suspended in ash matrix; scattering of pumices
R1S8E	ignimbrite	moderately sorted with lots of glass and no grading; lithic pieces by minor and are subangular to subrounded; Plagioclase minerals with minor quartz
R1S11To p	ignimbrite	high amount of glass shards and poorly to moderately sorting of angular to subangular minerals with occasional lithic and pumice clasts; elongated minerals look imbricated in sections.
R1S11Bot	ignimbrite ignimbrite	poor to moderately sorted with lots of glass, some minerals and little lithics; one lithic contains plagioclase mineral; clast supported and angular to subangular; looks imbricated in section

R1S12To p		upper portion is massive and glassy with very few minerals scattered; glass size increased while approaching the iron band; minerals look to be plagioclase and small amount of quartz
R1S12Bot	ignimbrite	same above and separated from bottom by sharp contact; bottom is pumices suspended in ash matrix; little to no minerals
R1S13	ignimbrite	massive and poorly sorted with angular to subangular minerals suspended in matrix of glass shards
R1S15E	ignimbrite	Pumice and glass rich; massive and poorly with angular to subangular mineral; sorted with plagioclase and minor lithics; lithic are subround to subangular
R1S15W	ignimbrite	same as above but with more minerals and slightly more angular
R1S18A	Rhyolite tuff/ignimbrite	quartz and plagioclase minerals poorly sorted angular to sub angular; lithic are subangular to round; glass shards
R1S21A	ignimbrite	lots of glass and bits of fibrous pumices; poorly sorted with plagioclase and subangular to subround lithic pieces that are not pumice;
R1S21B	ignimbrite	lots of glass and pumice and moderate lithics; lithics are subangular to subround; poorly to moderately sorted with plagioclase and little quartz; ignimbrite due to pumices being still angular and can be a good indicator for deposition environment
R1S24AT op	Sediment	moderately sorted sub angular to subround minerals, mostly quartz and moderate plagioclase; no imbrication or grading
R1S24AB ot	Sediment	upper portion is similar to 24A, but there is an increase in glass; coarse material seems to grade into fine material of glass shards; few minerals present most are quartz with some feldspar; lots of lithics in top of the coarse area
R1S24B	ignimbrite/ slight reworked ignimbrite	lots of glass shards and scattering of minerals; well sorted subangular to subround quartz and plagioclase; coarse to fine grading with lots of glass in the fine area that appears to have been reworked
R1S24C	ignimbrite	massive fines with well to moderately sorted areas; minerals are mostly subround to round and are plagioclase or quartz; minerals are mostly contained in glassy matrix; glassier than sample 24B
R1S29To p	ignimbrite	can be divided into three section in slide top, mid, and bot. poorly sorted with lots of glass scattered plagioclase minerals subangular to angular with a few rounded lithics. Middle: mod sorted and coarse grading toward bottom layer; glass is thinner and areas have more mineral present but same shape and type; Bottom:

		coarse with large mineral and lithics; most material is pumice pieces with little to no minerals
R1S29Bot	ignimbrite	mostly glass shards that appear to be imbricated scattering of minerals that are subrounded to subangular and lithics; poorly sorted
F1S11	ignimbrite	poorly sorted with lots of angular to subangular minerals of plagioclase and quartz; scattering of subround to round lithics;
F2S3Atop	minimal reworked ignimbrite	Laminated fines that look like very small glass, but not sure; fine material seems to grade and have freckled amounts of quartz
F2S3Abot	minimal reworked ignimbrite	same as above but with more sprinkle layers with slightly high concentrations of minerals; overall sample looks well sorted
F2S3Btop	minimal reworked ignimbrite	mostly laminar fine glass shards. In coarse pockets is sub round to round lithics of pumice and brown/grey material; very little minerals found but seems to be the few quartz and field.
F2S3Bmid	minimal reworked ignimbrite	fine material with little to no minerals even in the coarse pockets; coarse bits are pumices mostly
F2S3Bbot	minimal reworked ignimbrite	starts as massive very fine layer with scatter band of lapilli pumices 2mm to 5mm thick; towards bottom sharp contact into well sorted and graded sand layer with lots of angular to subangular minerals of plagioclase and quartz; at top grading coarsens with more glass and fewer minerals; there is a large 2mm fine clast square where it has been cracked and minerals penetrated into it like it is spilling or leaking into it; moderately sorted at bottom and glass and mineral rich; pumice rich to mineral rich with glass all the way through with a sharp contact indicates ignimbrite
F2S3C	minimal reworked ignimbrite	mostly lithics and glass with small angular to subangular minerals of quartz and feldspar; material grades to high concentration of fines; laminated fines the rest of the way after a sharp contact;
F5S2	ignimbrite	matrix supported angular to subangular minerals of plaioclase and quartz; poorly sorted
F6S2upAtop	ignimbrite	top of slide has large pumice with dash of minerals; moderate ironstaining acting as a cement in places; sharp change to poorly sorted glass, quartz, and plagioclase; small amount of lithics and pumices present; grades to coarse large clasts supported material at bottom of slide
	ignimbrite	

F6S2upA Bot		Similar to above, but gets a higher concentration of lithics and pumice in middle; minerals are subangular to sounround
F6S2Blow top	ignimbrite	similar to the bottom samples but has moderate sorting and a fine bands in the middle; grades to coarse material; plagioclase and quartz present and angular to subangular
F6S2Blow Bot	ignimbrite	poorly sorted and very coarse with round pumices; glass and angular minerals; and quartz present
R2S2.2	ignimbrite reworked	weather and fractured material with fines and scattering of minerals; minerals are plagioclase ad quarts angular to subangular; grades to medium material well to moderately sorted subangular to subround; texture similar to that in sample R2S2.1A
R2S2.1A	ignimbrite reworked- land slide	lithics of round to sub round some have angular minerals in them; minerals and lithics are clast supported, but lots of glass shards are present; lots of large pumices and minerals both are subangular to subround; plagioclase, quartz, hornblend present and another with high relief grey/blue to colourss in normal light but high biofringe in cross pol light; pumice appear to be fresh and streaked
R2S2.1B1	ignimbrite reworked; landslide	lithics of round to sub round some have angular minerals in them; minerals and lithics are clast supported; lots of large pumices and minerals both are subangular to subround; plagioclase, quartz present and another with high relief grey/blue to colourss in normal light but high biofringe in cross pol light; pumice appear to be fresh and streaked
R2S2.2lo B2	ignimbrite reworked; landslide	Similar to sample above but has fine portion with few minerals and fine from larger minerals to smaller; mostly plagioclase and quartz b very few biotite; glass shards present but very small
R2S3upA	slightly reworked ign	similar to sample B but even fewer minerals; angular to sub angular plagioclase and quartz; lost of glass
R2S3upB	slightly reworked ign	same as A
R2S3LoA	slightly reworked ign	well to moderate sorted and lots of glass and pumice with few minerals; minerals are mostly quartz present with some plagioclase
R2S3LoB	slightly reworked ign	coarse poorly sorted lapilli pumice and minerals suspended in matrix and grade to finer materials with lots of glass shards; Clast of lithics and pumice round to sub round; minerals are angular to sub angular; mostly quartz with few plagioclase; lots of glass
R2S3L4A	reworked ign	Pumice bomb mostly with some material around the outside; contains trace quartz and plagioclase minerals that are mostly large and angular

R2S4L4B	reworked ign	Large pumice with fine slightly iron stained section on one side; iron acting as a cement; little to no minerals or large material
R2S4L5T op	reworked ign	moderately sorted glassy bits what are imbricated; rounded lithics with subangular to subround minerals; massive;
R2S12	unknown	lots of glass and decently preserved but sitting clay; does not have gradation almost like they are separate; SEM conducted. ; mafic minerals are present and has a high concentration of them; describe this and the SEM photos and compare to other samples for now. it seems complex.

APPENDIX II

Field Code	Station	NZ Transverse Mercator 2000 North	NZ Transverse Mercator 2000 East	North	East	Waypoint	Formation	Notes
RV1	1	5809176	1806636				sedimentary	location taken from map not waypoints
RV1	2	5809264	1806544				sedimentary	location taken from map not waypoints
RV1	3	5809377	1806600				sedimentary	location taken from map not waypoints
RV1	4	5809632	1806125	6371254	2716359	1	sedimentary	
RV1	5	5809737	1805735	6371360	2715969	3	sedimentary	
RV1	6	5809944	1805407	6371567	2715642	4	sedimentary	
RV1	7	5810775	1804733	6372399	2714969	5	unknown	resembles a poorly sorted Ignimbrite Originally though sediment, results show ign and sed
RV1	8	5810700	1804688	6372324	2714924	6	contact_type1	ignimbrite under sediment. Samples have showed lots of glass
RV1	8.1	5810699	1804686	6372323	2714922	7	fault	Fault was 047/85 BEDS 099/02, 080/03, 081/03, 022/03
RV1	9	5810877	1804822	6372501	2715058	8	sedimentary	Beach landing with sediment but unsure if it is TPA or hinuera
RV1	10	5810849	1804856	6372473	2715092	9	contact_type1	ignimbrite under sediment
RV1	11	5810985	1805044	6372608	2715280	10	ignimbrite	hard with mafic crystals but has fine sandy rock and crystal rich. Content of glass and it's lack of weathering makes up conclude that it is ignimbrite; appears to be sediment due to bedding structures similar to st7
RV1	12	5811462	1805104	6373085	2715341	11	ignimbrite	
RV1	13	5811582	1805045	6373205	2715282	12	ignimbrite	
RV1	14	5812153	1804596	6373777	2714834	13	sedimentary	
RV1	15	5811849	1804672	6373473	2714910	14	ignimbrite	
RV1	16	5812974	1803844	6374599	2714084	15	ignimbrite	contains both ignimbrite and Hinuera
RV1	16.1	5812992	1803829	6374617	2714069	16	fault	
RV1	16.2	5813087	1803805	6374712	2714045	17	sedimentary	

RV1	17	5813310	1803765	6374935	2714005	18	unknown	Pale cream YLW-WHTish. Thin-med bedded pumiceous sands and gravel alternating with pebbly-gravel lithic rich sand and gravels. Sandy layers thinner. Planar bedded but some fine layers are discontinous. Unsure if sed or ignimbrite because it looks like sediment but it is crystal rich and has bedds located on lower portion just above the water
RV1	17.1	5813357	1803648	6374982	2713888	19	ignimbrite	Went up river and changed to ignimbrite along the west bank. Marked location of ignimbrite.
RV1	18	5813356	1803472	6374981	2713712	20	ignimbrite	Ignimbrite with sediment on top similar to station 7; ignimbrite
RV1	19	5813111	1803193	6374737	2713433	21	contact_type2	sediment in contact with volcanic deposits layered bedding with Pink staining and hard cement. Sand well sorted and fine layer on bottom, sand upper layers are light orange where as the clay and silt below is light grey whitish. Seidment unit possible, maybe Karipiro.
RV1	20	5813073	1802967	6374699	2713207	22	unknown	small island in middle of the river. On the surface the colour is whitish with pink staining. Was unsure if sed or ignimbrite in field. samples indicate ignimbrite
RV1	21	5813035	1802411	6374662	2712651	23	ignimbrite	Possible ignimbrite but Unsure. Whitish and no bedding. need more information because close examination seems like it is made of sediments.
RV1	22	5813165	1802280	6374792	2712520	24	unknown	appears to be Hinuera
RV1	23	5813372	1801727	6375000	2711968	25	sedimentary	Thin sections beofre mounting were indicating some character of ignimbrite. after review of thin sections samples look eto be ignimbrite or a ignimbrite that has been slightly reworked.
RV1	24	5813457	1801661	6375085	2711902	26	ignimbrite	
RV1	25	5814153	1801437	6375781	2711679	27	sedimentary	
RV1	26	5814969	1801613	6376596	2711856	28	sedimentary	Sedimentary (possible Hinuera) confired at this out crop. Coarse sand and gravels of pumce and lithics present.
RV1	26.1	5815695	1800975	6377323	2711220	29	sedimentary	Hinuear @marked 26a

RV1	27	5816028	1800944	6377656	2711189	30	unknown	Out crop has crossbedding sediments that are heavily iron stained and slightly cemented even in the cross bedding orientation. Landslide in area shows debries has pumice gravels coarse and pumiceous.
RV1	28	5816396	1800737	6378024	2710983	31	sedimentary	Pumice is in contact with each other but no matrix present (TPA). Walking along the bank and we got layers of coarse sand and minor silt layers over layer (bed) of silty clay. These parts are Hinuera reworked ignimbrite material, looks to belong to the WSG just not sure if Puketoka or karaprio
RV1	29	5818088	1799550	6379718	2709799	32	ignimbrite	reworked ignimbrite material, looks to belong to the WSG just not sure if Puketoka or karaprio
RV1	30	5818178	1799463	6379808	2709712	33	ignimbrite	reworked ignimbrite material, looks to belong to the WSG just not sure if Puketoka or karaprio
RV1	31	5818464	1799280	6380094	2709529	34	ignimbrite	reworked ignimbrite material, looks to belong to the WSG just not sure if Puketoka or karaprio
RV1	32	5821079	1797166	6382712	2707420	35	unknown	Sediment based outcrop. Has areas that look like TPA. Cream in colour coarse sand and gravels material on lower protion. Above matierial is white and fine, looks different from below and though appears to be massive, there it appears to be multiple beds of massive white.
RV1	33	5819371	1799641	6381000	2709892	36	sedimentary	
F1	1	5810676	1804448	6372300	2714684		unknown	
F1	2	5810600	1804517	6372224	2714753	37	unknown	
F1	3	5810561	1804480	6372185	2714716	38	unknown	
F1	3.1	5810563	1804481	6372187	2714717	39	unknown	
F1	4	5810630	1804560	6372254	2714796	40	sedimentary	appears to be massive with large pumice within; mica and quartz Large clasts (lithics) approximately 40mm wide for some. Harder toward the base, less on top. Dug Deeper and deposit becomes silty. Predominantly sandy towards top. Baseed on appearance it seems like it is graded coarse to silt from top to bottom. But outcrop is really dry and dusty.
F1	5	5810813	1804554	6372437	2714790	41	unknown	
F1	6	5811148	1804663	6372772	2714900	42	sedimentary	

F1	6.1	5811149	1804662	6372773	2714899	43	sedimentary
F1	7	5811384	1804581	6373008	2714818	44	ignimbrite
F1	7.1	5811480	1804587	6373104	2714824	45	ignimbrite
F1	8	5811479	1804588	6373103	2714825	46	ignimbrite
F1	9	5811609	1804681	6373233	2714918	47	sedimentary
F1	9.1	5811608	1804682	6373232	2714919	52	sedimentary
F1	10	5811274	1804541	6372898	2714778	48	ignimbrite
F1	11	5811117	1804500	6372741	2714737	49	ignimbrite
F1	12	5811093	1804560	6372717	2714797	50	ignimbrite
F1	13	5811363	1804709	6372987	2714946	51	sedimentary
<hr/>							
F2	1	5820526	1798263	6382157	2708516	53	sedimentary
F2	2	5820651	1798037	6382283	2708290	54	ignimbrite
F2	3	5820702	1798040	6382334	2708293	55	ignimbrite
F2	3.1	5820835	1797975	6382467	2708228	57	ignimbrite
F2	4	5820835	1797975	6382467	2708228	58	ignimbrite
F2	4.1	5820848	1797929	6382480	2708182	59	ignimbrite
F2	4.2	5820836	1797910	6382468	2708163	60	ignimbrite
F2	5	5819735	1799224	6381365	2709475	61	sedimentary
F2	6	5819521	1799435	6381151	2709686	62	sedimentary
F2	6.1	5819479	1799471	6381109	2709722	63	sedimentary
F2	7	5818709	1799400	6380339	2709650	64	ignimbrite
F2	8	5818494	1799265	6380124	2709514	65	ignimbrite
F2	9	5819690	1799310	6381320	2709561	67	sedimentary
F2	10	5816169	1800785	6377797	2711030	98	ignimbrite
F2	10.1	5816283	1800676	6377912	2710922	99	ignimbrite
F2	10.2	5816361	1800609	6377990	2710855	100	fill
F2	10.3	5816369	1800600	6377998	2710846	101	fill
F2	10.4	5816629	1800312	6378258	2710558	102	fill
<hr/>							
F3	1	5818928	1799699	6380557	2709949	68	sedimentary
F3	1.1	5818788	1799673	6380418	2709923	69	sedimentary
F3	2	5818479	1799350	6380109	2709599	70	sedimentary
F3	2.1	5818462	1799388	6380092	2709637	71	sedimentary
F3	3	5818226	1799449	6379856	2709698	72	sedimentary

F3	4	5819046	1799664	6380675	2709914	73	unknown	platform of a deposit that drops away sharply. material was grey silty with medium iron staining. could be hinuera. Photos taken but no smaple.
F3	5	5820625	1798250	6382256	2708503	74	unknown	Took photos at the level of the path to get better depth perception of this because it is strange this one spot of the path dips. This dip also aligns to the other side where we saw the sediment deposit that may have a seismite. could not see outcrop due to water level being high
F3	6	5820551	1798535	6382182	2708788	76	sedimentary	
F3	7	5819488	1799694	6381117	2709945	77	sedimentary	
F3	8	5817163	1799905	6378793	2710152	78	Fill	Ground has been manicured for foot path and most out crops appear to be sediment based fill.
F4	1	5813408	1803407	6375033	2713647	79	Hamilton Ash	
F4	2	5813433	1803464	6375058	2713704	80	Hamilton Ash	
F4	3	5813415	1803515	6375040	2713755	81	Hamilton Ash	
F4	4	5813414	1803551	6375039	2713791	82	ignimbrite	
F4	5	5813419	1803594	6375044	2713834	83	ignimbrite	
F4	6	5813416	1803654	6375041	2713894	84	Hamilton Ash	
F4	7						Hamilton Ash	
F4	8	5813423	1803665	6375048	2713905	85	Hamilton Ash	
F5	1	5813212	1803827	6374837	2714067	87	sedimentary	
F5	2	5813207	1803826	6374832	2714066	88	ignimbrite	
F5	3	5813042	1803886	6374666	2714126	89	sedimentary	
F5	3.1	5812988	1804021	6374612	2714261	90	sedimentary	
F5	3.2	5813005	1804066	6374629	2714306	91	sedimentary	
F5	4	5813019	1804116	6374643	2714356	92	ignimbrite	
F5	5	5812999	1804159	6374623	2714399	93	ignimbrite	
F5	6	5813007	1804208	6374631	2714448	94	ignimbrite	
F5	6.1	5813008	1804181	6374632	2714421	95	ignimbrite	
F5	7	5812996	1804525	6374620	2714764	96	unknown	fine to medium sand that is silty with elements of clay. There are small pumice bits and Angular qtz and plag. Small dark minerals maybe ironbased litics. This appears to be non weathered ignimbrite.

F5	8	5812708	1804595	6374331	2714834	97	unknown	Area was overgrown and places seemed changed by building in areachanged by building but in drainage we can see what looks like ignimbrite but can't confirmed because drainage was unsafe.
F6	1	5817955	1799536	6379585	2709784	106	sedimentary	walking on sediment fill across river is ign
F6	1.1	5818014	1799499	6379644	2709747	107	sedimentary	walking on sediment fill across river is ign
F6	1.2	5818135	1799385	6379765	2709634	108	sedimentary	walking on sediment fill across river is ign
F6	1.3	5818212	1799301	6379842	2709550	109	sedimentary	walking on sediment fill across river is ign
F6	2	5818283	1799250	6379913	2709499	110	ignimbrite	increase in topo start of ignimbrite?
F6	2.1	5818281	1799228	6379911	2709477	111	ignimbrite	sediment on ground cliff ign
F6	2.2	5818272	1799241	6379902	2709490	112	ignimbrite	sediment on ground cliff ign
F6	2.3	5818354	1799227	6379984	2709476	113	ignimbrite	spring source
F6	3	5818415	1799234	6380045	2709483	114	sedimentary	based on steps present
F6	4	5818435	1799246	6380065	2709495	115	unknown	Looks like weather Ignimbrite but unsure could be fill
F6	5	5818492	1799259	6380122	2709508	116	ignimbrite	
F6	6	5818566	1799289	6380196	2709538	117	ignimbrite	large darinage with water fall Look like ignim
F6	6.1	5818618	1799338	6380248	2709587	118	ignimbrite	Slump could be associated with fault
F6	6.2	5818611	1799337	6380241	2709586	121	ignimbrite	ourcrop at slump
F6	7	5818649	1799349	6380279	2709598	119	fill	
F6	8	5818684	1799404	6380314	2709654	120	unknown	cant tell if fill or sediment
F7	1	5810799	1804860	6372423	2715096	122	sedimentary	beach
F7	1.1	5810792	1804850	6372416	2715086	123	sedimentary	beach
F7	1.2	5810783	1804834	6372407	2715070	124	sedimentary	beach
F7	1.3	5810772	1804822	6372396	2715058	125	sedimentary	beach
F7	1.4	5810756	1804804	6372380	2715040	126	sedimentary	beach
F7	1.5	5810736	1804790	6372360	2715026	127	sedimentary	heavy iron stained sediment making platform
F7	2	5810691	1804796	6372315	2715032	128	sedimentary	sediment
F7	2.1	5810698	1804810	6372322	2715046	129	sedimentary	TPA layer
F7	3	5810641	1804815	6372265	2715051	130	sedimentary	borehole 1
F7	4	5810598	1804842	6372222	2715078	131	sedimentary	bourehole2 in dip. Normal results
F7	5	5810648	1804843	6372272	2715079	132	sedimentary	mix sand with fine silt looks like it could be human influence, old kumra patch
F7	6	5810685	1804854	6372309	2715090	133	sedimentary	similar to st5, all holes are aligned
F7	7	5810779	1804843	6372403	2715079	134	sedimentary	

F7	7.1	5810763	1804820	6372387	2715056	135	sedimentary	rabbit holes showed sediment
F7	8	5810807	1804902	6372431	2715138	136	sedimentary	
F7	8.1	5810824	1804942	6372447	2715178	137	ignimbrite	hill steepen similar to Nor Hammond park
F7	9	5810789	1804915	6372413	2715151	138	ignimbrite	hill steepen similar to Nor Hammond park
F7	9.1	5810785	1804889	6372409	2715125	139	sedimentary	from hole dug in hill
F7	9.2	5810777	1804909	6372401	2715145	140	sedimentary	cant tell if debris sediment or natural too dry
F7	10	5810752	1804874	6372376	2715110	141	sedimentary	borehole
F7	10.1	5810772	1804925	6372396	2715161	142	sedimentary	borehole
RV2	1	5812587	1804553	6374211	2714792	143	sedimentary	The thick bands of rounded pumice mixed with chunks of charcole, yellow cream colour. show that the area is TPA.
RV2	1.1	5812579	1804556	6374203	2714795	144	sedimentary	TPA
RV2	2.1	5812894	1804089	6374518	2714328	145	sedimentary	fresh river terrace
RV2	2.2	5812893	1804049	6374517	2714288	146	sedimentary	fresh river terrace
RV2	2.3	5812889	1804045	6374513	2714284	147	unknown	looks like sediment. Unsure what it is. Has inclusion of large silt both angular and rounded, some 200mm wide and some 500mm. Pumice layer with no ash maxtric and seem to be sorted and rounded, which would relate to hinuera but still unsure. Poossible debrite from an ignimbrite or regular sedimentary
RV2	2.4	5812897	1804069	6374521	2714308	148	unknown	looks like sediment
RV2	2.5	5812887	1804005	6374511	2714244	149	ignimbrite	3 sequenced flow ignimbrite.
RV2	2.6	5812877	1804017	6374501	2714256	150	ignimbrite	3 sequenced flow ignimbrite.
RV2	2.7	5812892	1804015	6374516	2714254	151	sedimentary	Walking the contact back down this we foudn sediment again marked at 151. The sediment is below the iginbrite.
RV2	2.8	5812910	1804019	6374534	2714258	152	contact_type2	Incase the signal in the tress was off I got another location on 152 and 153 via hte boat on the river outside the trees but infron tthe spots we were out. This area could be a faul tor discontinuity. there is an uppe rterrace then the hill, the terrance ignimbrite on sediment
RV2	2.9	5812912	1804024	6374536	2714263	153	contact_type2	

RV2	3	5818180	1799463	6379810	2709712	154	ignimbrite	revisit from R1ST30 and 29 days park east bank area. Looks to be a fall deposit that is alluvial sequence but @ bottom seiment unit we think bottom is Karipiro=Fluvial reworkeded, then the coarse band is a fall deposit. Sampled lower and uppe rbanding ash th
RV2	3.1	5818097	1799528	6379727	2709777	155	ignimbrite	revisit from R1 (RV1ST30 and 29).Went up River to massive what layers and outcrop for another look to compare to ST3. Samples confirm a reworked ignimbrite
RV2	4	5818238	1799418	6379868	2709667	156	ignimbrite	reworked ignimbrite.
RV2	5	5818238	1799419	6379868	2709668	157	ignimbrite	small out crop 1 meter above the river and next to southern boundary of Day's park . Simalr stuff here as to the toher site at 3 and 4.
RV2	6	5819733	1799297	6381363	2709548	158	sedimentary	across standres golf coarse where we scrapped for F2. cross beds and pumice= Hinuera
RV2	7	5821276	1797031	6382909	2707285	159	sedimentary	Alternation beds of coarse to medium sand with silty sand layer . The sands have cross bedding in serveral locations=Hinuera
RV2	8	5821393	1797009	6383026	2707263	160	unknown	Looks volcanic. Whiteout crop with fine massive top part. Material feels like a fluffy silt (pyroclastic ash?)Below is a coarse lappili layer with pumice horizontally layered, but no cross bedding present. Has coarsening and fining with alteration in col
RV2	9	5822617	1796381	6384251	2706637	161	sedimentary	TPA across river looks like Hinuera but could not obsever
RV2	10	5825426	1794507	6387062	2704768	162	unknown	Looks like possible volcanic. On the surface material is yellow white but augered deep shows green blue colour . It is clay with lots of coarse sandy material grains are sub angular in places
RV2	10.1	5825429	1794488	6387065	2704749	163	unknown	looks volcanic
RV2	10.2	5825438	1794460	6387074	2704721	164	unknown	looks volcanic

RV2	11	5825414	1794615	6387050	2704876	165	unknown	south past bridge at station 10. trying to back track and look for same contact. Found outlet on east side river. Scrapped to find a clay material with coarse sand. It was hard and really iron stained in places shaping the beach platform. Samples collected
RV2	12	5825388	1794585	6387024	2704846	166	unknown	Checked opposite side of ST11 on the west bank and also found similar stuff to station 10 east side river to see if outcrop of white from ST10 has switched sides. We spaded a section and found we do have similar material. Samples collected
RV2	13	5825307	1794715	6386943	2704976	167	sedimentary	organic materials when augered. looks volcanic. east river down closer to the expressway bridge. White bank was checked with auger. Found clay with lots of coarse sandy material similar to what we saw at station 10. samples collected
RV2	14	5825326	1794761	6386962	2705022	168	unknown	
RV2	15	5821998	1796703	6383631	2706958	169	unknown	Narrow river passage and sonar on boat indicates a scower hole in location. There is a sudden drop and hard rock it seems below then a shallow area.
RV2	15.1	5821829	1796853	6383462	2707108	170	unknown	Narrow river passage and sonar on boat indicates a scower hole in location. There is a sudden drop and hard rock it seems below then a shallow area.
RV2	16	5820974	1797950	6382606	2708203	171	unknown	outcrop peaking out on a high area of hill side at this location on the east side. Could not observe close up because of location but got photos with a zoom lens to help evaluate
Kay	1	5823914	1799007	6385543	2709265			fault zone in road cutting does not cut ashes
Osborne	1	5824531	1797120	6386163	2707380			fault Ben C site

APPENDIX III

