

# FLIPPED CLASSROOM LEARNING IN A FIRST-YEAR UNDERGRADUATE ENGINEERING COURSE

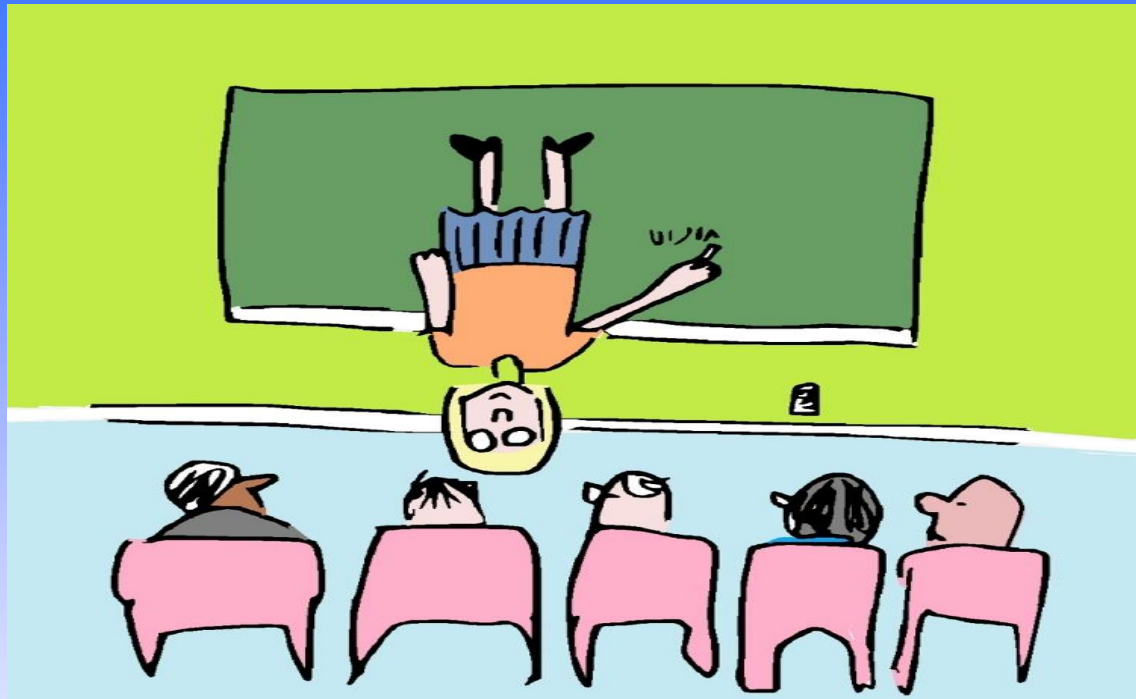

Elaine Khoo, Mira Peter, Jonathan Scott  
& Howell Round

UNIVERSITY OF WAIKATO  
NEW ZEALAND



Wilf Malcolm Institute  
of Educational Research

*Te Pūtahi Rangahau Mātauranga o Wilf Malcolm*

THE UNIVERSITY OF WAIKATO



TEACHING & LEARNING  
RESEARCH INITIATIVE

NĀU I WHATU TE KĀKAHU, HE TĀNIKO TAKU

# OUR INTERDISCIPLINARY TEAM



Wilf Malcolm Institute  
of Educational Research

*Te Pūtahi Rangahau Mātauranga o Wilf Malcolm*

THE UNIVERSITY OF WAIKATO



TEACHING & LEARNING  
RESEARCH INITIATIVE

NĀU I WHATU TE KĀKAHU, HE TĀNIKO TAKU

# FLIPPED CLASSROOM

A move away from using class time for lecturing

Students engage with new class material for the first time outside of class

Part/all of instruction through **videos/other medium**

Class time is used for the **harder work** of assimilating and applying that knowledge

Students gain **responsibility** for their learning  
(studying course material outside of class)

Instructors = **facilitators** of the learning process, guides students to apply concepts and engage creatively in the subject matter

Class time becomes **dynamic, interactive learning environment**

# OUR STUDY

**Design-based research** (DBR) approach,  
practitioner-led cycles of planning, design and  
implementation

Two-year funded research project  
investigating the **impact of using a flipped class  
approach** on student learning in a first-year  
engineering course that involved **threshold  
concepts** (TCs)

# THRESHOLD CONCEPT (TC) THEORY

“In each academic discipline, there exist special concepts  
- *threshold concepts* -  
that once grasped, reveal new and previously inaccessible ways of thinking about a subject”.

(Meyer & Land, 2003)

# TCs ARE:

**TRANSFORMATIVE:** we are (become) what we know

**IRREVERSIBLE:** difficult to unlearn  
(learners cannot return to previous view of the world)

**INTEGRATIVE:** cohere key aspects of the subject  
(reveal hidden inter-relatedness & connections between apparently disparate information)

**BOUNDED:** delineate a particular conceptual space  
(serving a specific and limited purpose)



**BUT...**

# TCs ARE:

**TROUBLESOME!** counter-intuitive, difficult to learn,

**AND...**

**STUDENTS TEND TO GET STUCK!**



# How can lecturers help students to *transition...*

FROM BEING STUCK...



TO

MASTERING TCs



# OUR RESEARCH CONTEXT



DE-CLUTTER THE  
CURRICULUM



# OUR RESEARCH CONTEXT

IFAT

## IMMEDIATE FEEDBACK ASSESSMENT TECHNIQUE (IF AT®)

Name \_\_\_\_\_

Test # \_\_\_\_\_

Subject \_\_\_\_\_

Total 32

### SCRATCH OFF COVERING TO EXPOSE ANSWER

	A	B	C	D	E	Score	
1.	<input type="checkbox"/>	<input type="checkbox"/>	<input checked="" type="checkbox"/>	<input type="checkbox"/>	<input type="checkbox"/>	5	_____
2.	<input checked="" type="checkbox"/>	<input type="checkbox"/>	<input type="checkbox"/>	<input type="checkbox"/>	<input type="checkbox"/>	5	_____
3.	<input type="checkbox"/>	<input type="checkbox"/>	<input checked="" type="checkbox"/>	<input type="checkbox"/>	<input type="checkbox"/>	2	_____
4.	<input type="checkbox"/>	<input type="checkbox"/>	<input type="checkbox"/>	<input type="checkbox"/>	<input checked="" type="checkbox"/>	2	_____
5.	<input type="checkbox"/>	<input checked="" type="checkbox"/>	<input type="checkbox"/>	<input type="checkbox"/>	<input type="checkbox"/>	0	_____
6.	<input type="checkbox"/>	<input type="checkbox"/>	<input checked="" type="checkbox"/>	<input type="checkbox"/>	<input type="checkbox"/>	5	_____
7.	<input type="checkbox"/>	<input type="checkbox"/>	<input type="checkbox"/>	<input checked="" type="checkbox"/>	<input type="checkbox"/>	5	_____
8.	<input checked="" type="checkbox"/>	<input type="checkbox"/>	<input type="checkbox"/>	<input type="checkbox"/>	<input type="checkbox"/>	1	_____
9.	<input type="checkbox"/>	<input type="checkbox"/>	<input type="checkbox"/>	<input checked="" type="checkbox"/>	<input type="checkbox"/>	5	_____
10.	<input type="checkbox"/>	<input type="checkbox"/>	<input type="checkbox"/>	<input type="checkbox"/>	<input checked="" type="checkbox"/>	2	<u>32</u>

# OUR RESEARCH CONTEXT

## ONLINE TUTORIALS

### 107. Thévenin 4b

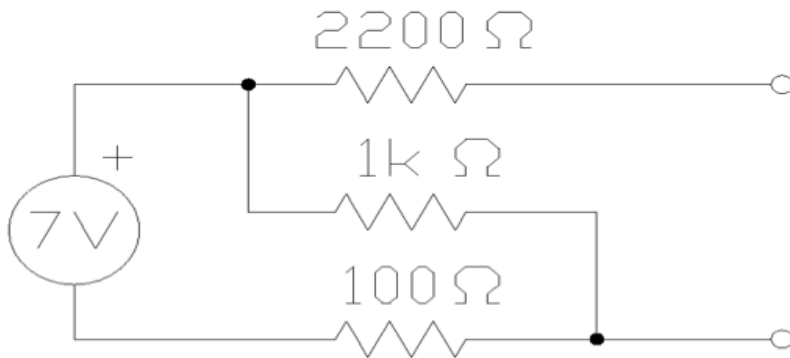

What is the Thévenin equivalent resistance of this circuit?

Select an Answer

- 2290 Ohms
- 2300 Ohms
- 3200 Ohms
- 3300 Ohms

Reason for your Answer

Please give a reason for your answer...

Submit

### Resource Links

Need some help? Try these links...

#### Section Links

[Hyperphysics - Current Law](#)

#### General Links

[Hyperphysics](#) [Electronic-Tutorials.ws](#) [All About Circuits](#) [Electronics Club](#) [MIT Electronics Videos](#)

# OUR RESEARCH CONTEXT

Traditional first-year Introduction to electronics engineering

Conceptually challenging

~150 students

2 lecturers (analog & digital)

6 weeks each

1 2hr face-to-face tutorial

1 lab/week

2-3 lab demonstrators

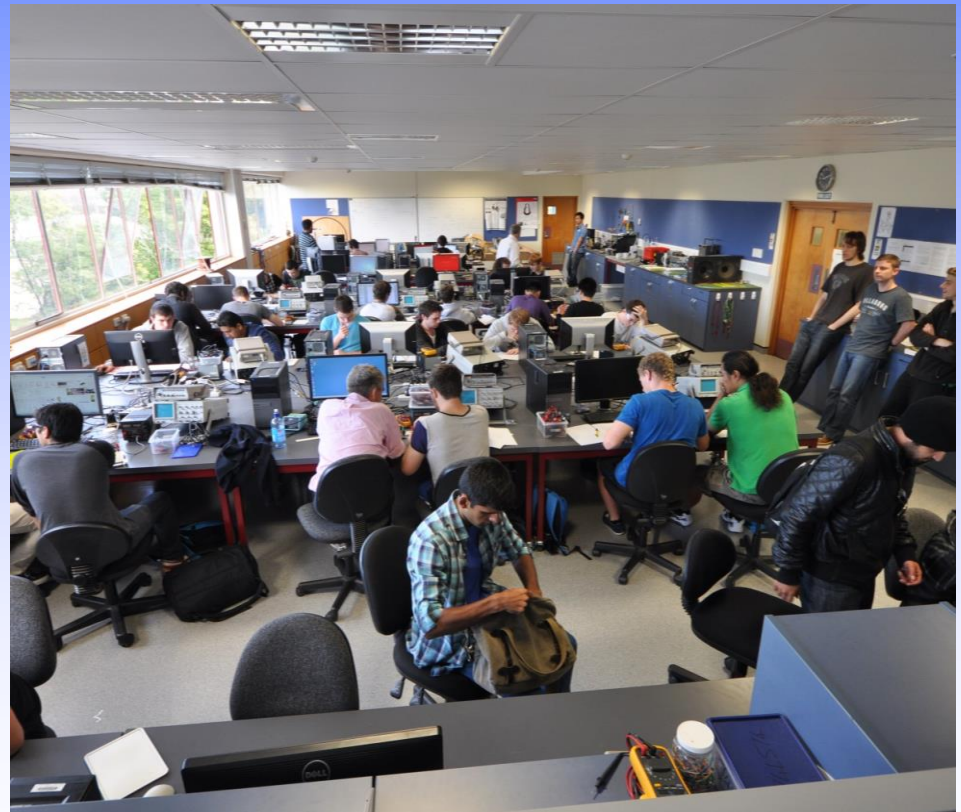

SINCE SUMMER 2014...  
5 CYCLES OF FLIPPING

# CYCLE 1: PREPARATIONS...

Looked at (what makes) good education videos  
Sorden (2005) - (e.g., coherence, redundancy, spatial & temporal contiguity)

Recorded lecturer purpose-developed videos and supplemented  
Youtube videos ~60 videos @ ~8-13 minutes each  
(3 months learning, planning, recording, watching YouTube)

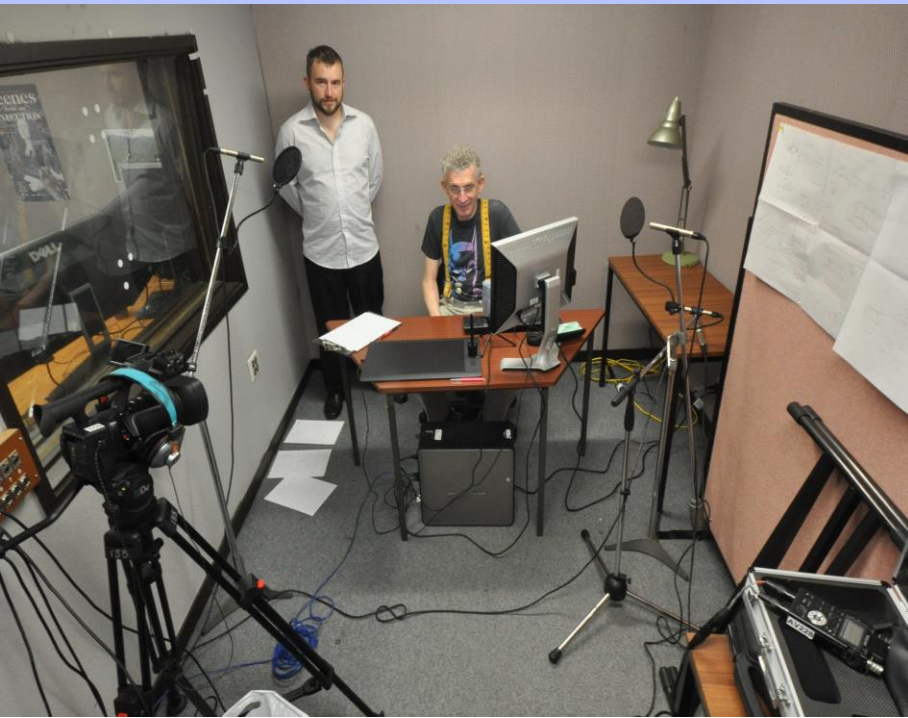

- Netlists  
of circuits

- Recognising  
elements in  
series and parallel





$$V=IR$$

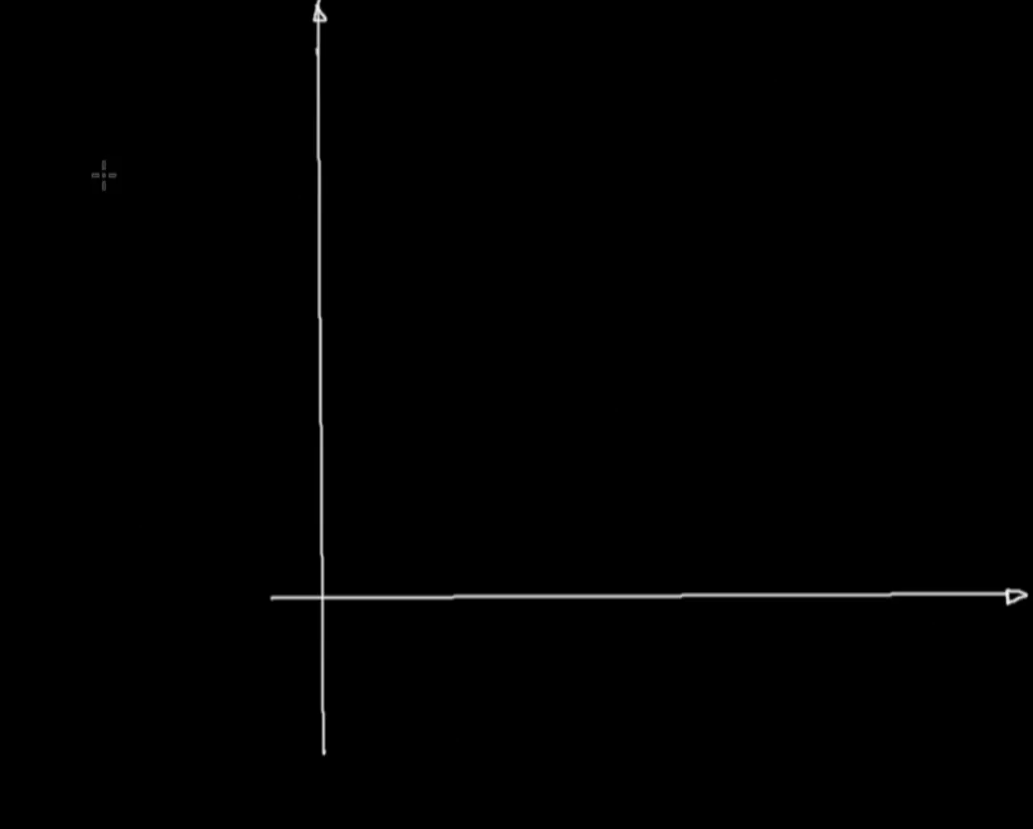

# CYCLE 2

Building on cycle 1, we added the following:

Monitored student video watching

Lecturer 1 - new  
Lightboard-based videos

Lecturer 2- Panopto-  
captured lecture videos

Continuous assessment

Revised problem solving  
questions



# CYCLE 3

Lecturer 2 purpose-developed videos

Monitored student video analytics (stricter) & Moodle usage logs

Increased support for student learning- drop-in session, Q&A forum

**Are steps a problem?**

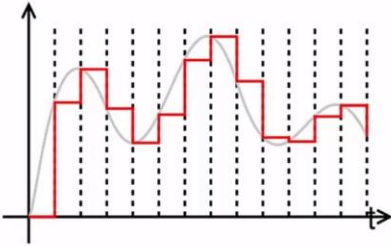

Not for sound as

- i) speakers will not operate fast enough to follow steps so sound coming out is a smoothed version of the steps
- ii) your ears can't hear above 20 kHz (can't sense the steps)

▶ 204 -307 1x Speed

# THE CLASS

2015, Sem. A -> **PARTIAL FLIP (3 weeks)** lecturer-created videos; + group problem solving activities

2015, Sem. T -> **FULLY FLIPPED** - 50% lecturer-created videos; + problem solving + continuous assessment

2016, Sem. A -> **FULLY FLIPPED** - 100% lecturer-created videos +, +

2016, Sem. T -> **FULLY FLIPPED** - 100% lecturer-created videos +, +

2017, Sem. A -> **FULLY FLIPPED** - 100% lecturer-created videos +, +

# WHAT THE FLIPPED CLASS LOOKED LIKE

3/week x 50 min. lectures replaced by videos

Lecture slot allocated for group problem-solving activities

Labs = 3 hours; in-class mini-lectures

Continuous assessment; extra tutorials, drop-in sessions on demand

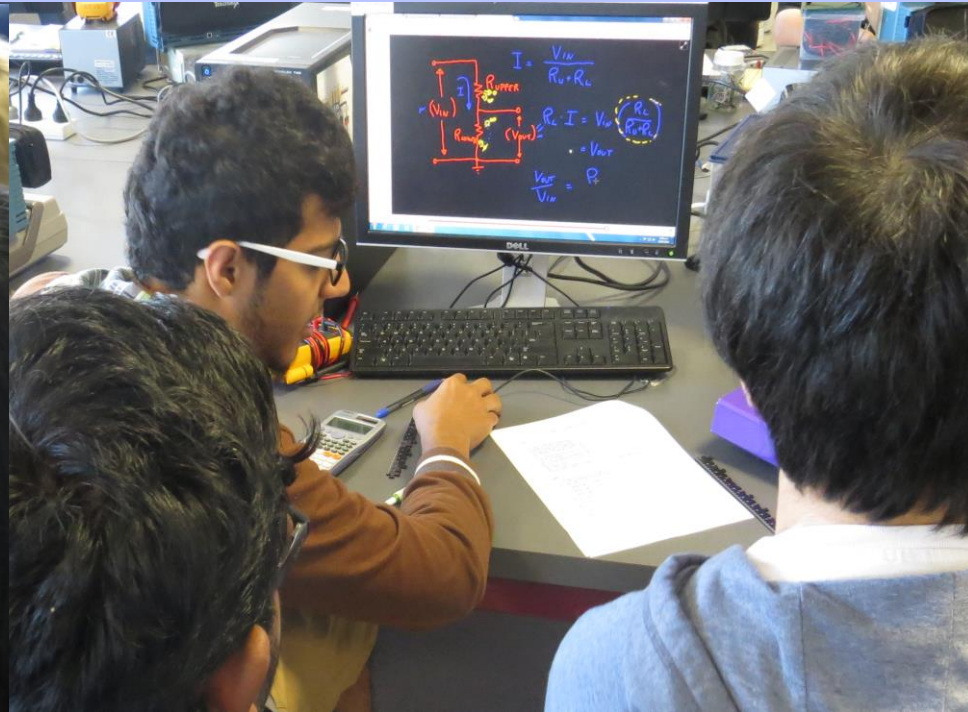

# STUDENT ACHIEVEMENT

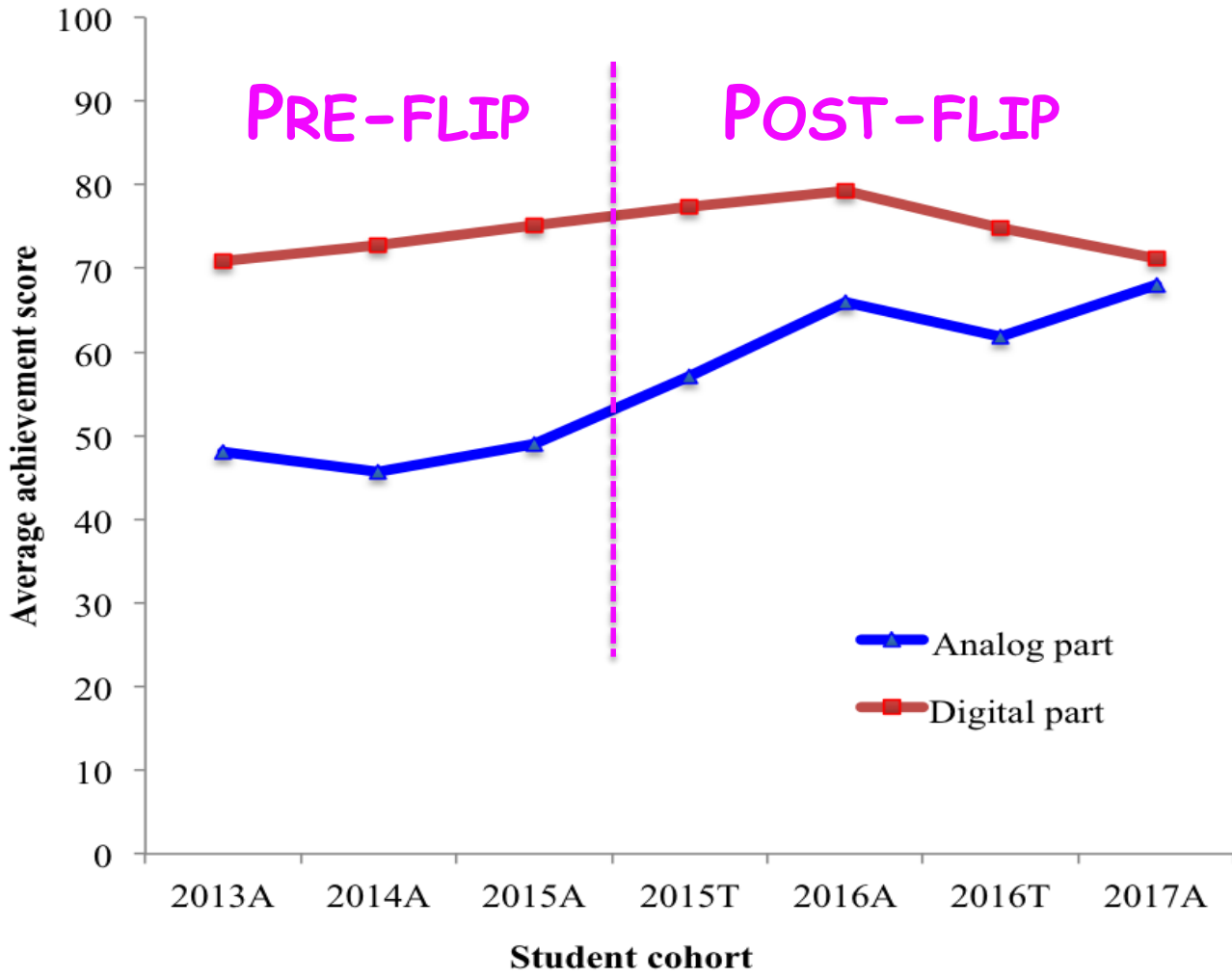

# VALUE OF VIDEOS?

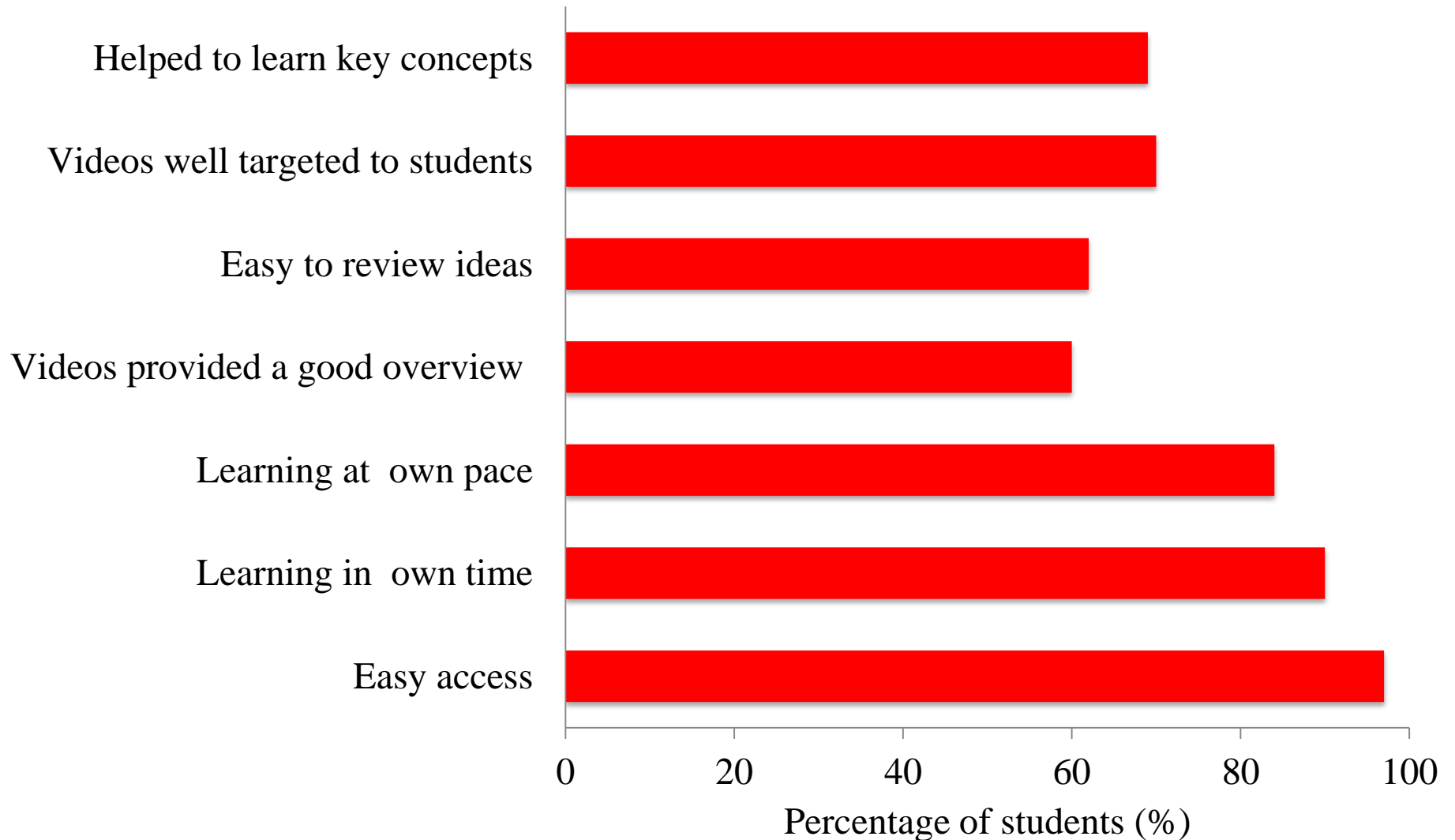

# VALUE OF GROUP WORK?

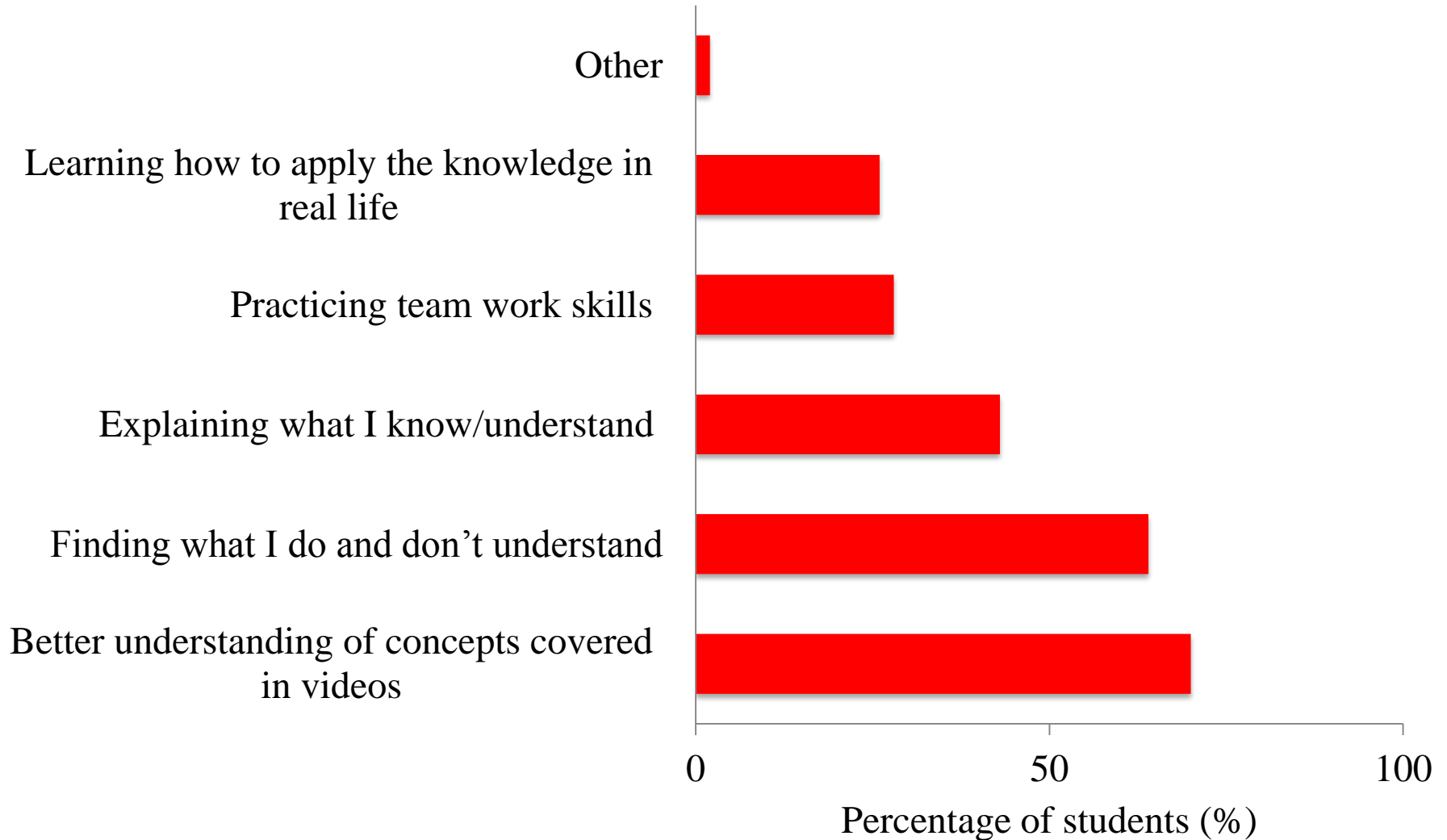

# HOW HELPFUL CONTINUOUS ASSESSMENT?

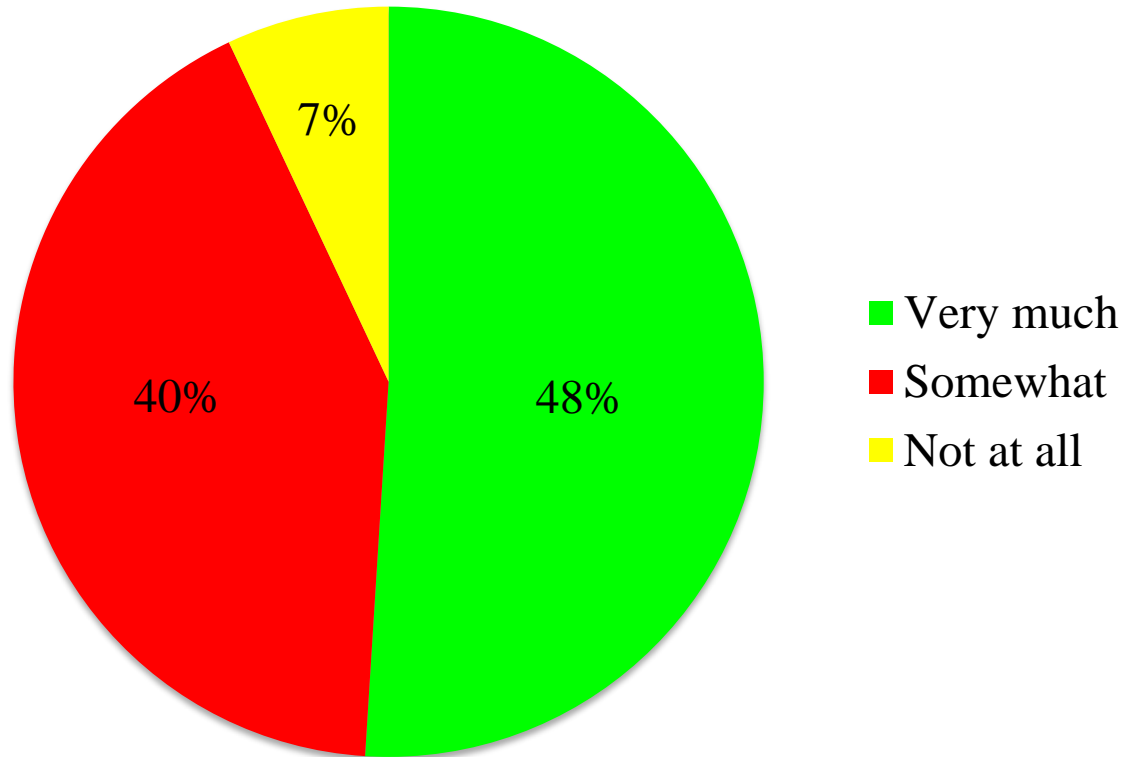

# FLIPPED VS TRADITIONAL

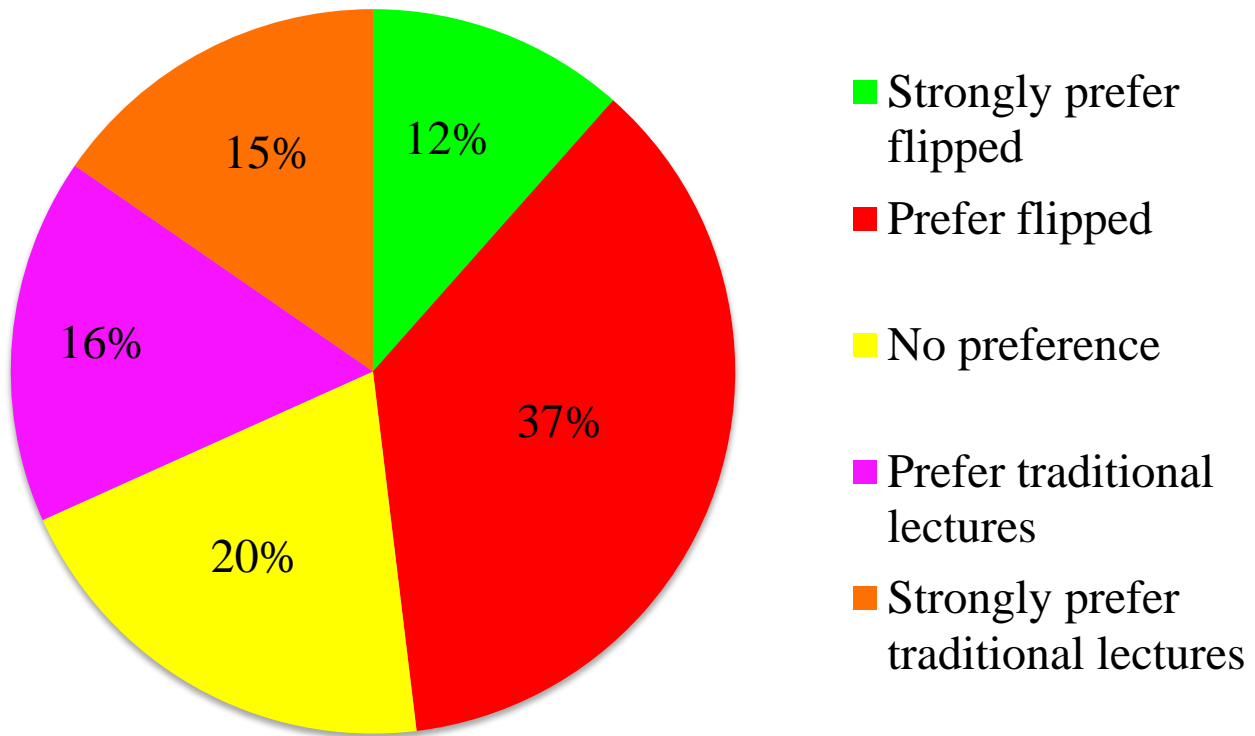

# LECTURERS' REFLECTIONS

Lecturers liked flipping the class!

Students were more engaged and seemed to enjoy the paper more as a result of flipping.

Frequent tests were good - students had to keep up to date.

Students need guidance on the order of lecturer purpose-made videos to watch (they seemed a bit overwhelmed by the number of video clips available).

Problem solving worked well - students found some of it a bit challenging, but they help to complement the lectures.

# IMPLICATIONS

## CURRICULUM

Refine course content and structure

Ensure coherence of overall course design

Make incremental changes

## PEDAGOGY

Short, educationally good quality videos are essential

Variety of learning supports

Changing lecturer role

# IMPLICATIONS

## ASSESSMENT

Continuous assessment

## STUDENT LEARNING

Changing student role

Learning technical and non-technical skills

## INSTITUTIONAL SUPPORT

Interdisciplinary collaboration

Time and incentive for lecturers

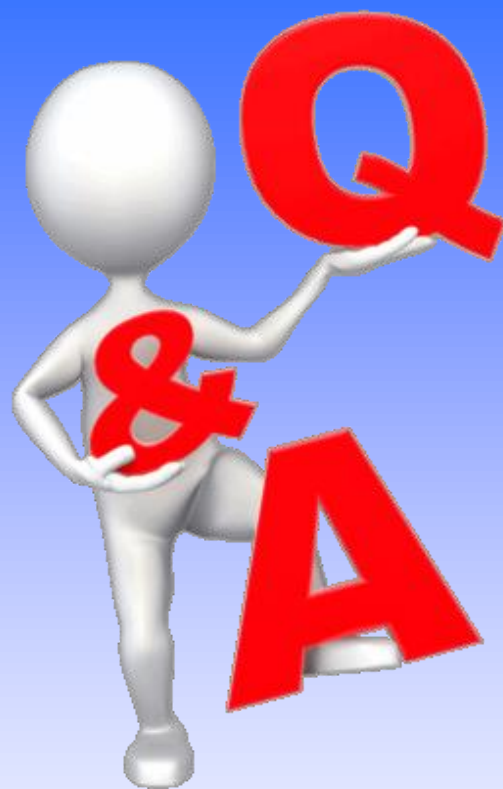

Wilf Malcolm Institute  
of Educational Research

*Te Pūtahi Rangahau Mātauranga o Wilf Malcolm*

THE UNIVERSITY OF WAIKATO



TEACHING & LEARNING  
RESEARCH INITIATIVE

NĀU I WHATU TE KĀKAHU, HE TĀNIKO TAKU