



THE UNIVERSITY OF
WAIKATO
Te Whare Wānanga o Waikato

Research Commons

<http://waikato.researchgateway.ac.nz/>

Research Commons at the University of Waikato

Copyright Statement:

The digital copy of this thesis is protected by the Copyright Act 1994 (New Zealand).

The thesis may be consulted by you, provided you comply with the provisions of the Act and the following conditions of use:

- Any use you make of these documents or images must be for research or private study purposes only, and you may not make them available to any other person.
- Authors control the copyright of their thesis. You will recognise the author's right to be identified as the author of the thesis, and due acknowledgement will be made to the author where appropriate.
- You will obtain the author's permission before publishing any material from the thesis.

**PROFESSIONAL DEVELOPMENT FOR A NEW
CURRICULUM IN A DEVELOPING COUNTRY: THE
EXAMPLE OF TECHNOLOGY EDUCATION IN THE
SOLOMON ISLANDS**

*A Thesis
submitted in fulfilment of
the requirements for the Degree*

of

Doctor of Philosophy

By

David Sade



The
**University
of Waikato**
*Te Whare Wānanga
o Waikato*

Centre for Science & Technology Education Research

Hamilton, New Zealand.

2009

ABSTRACT

This thesis explores the impact of a specially designed technology education professional development programme for traditional technical education secondary teachers to assist with the implementation of technology education in the Solomon Islands. Technology education is a new development for the teachers in Solomon Islands who are used to a more prescribed technical education. The technology education in the Solomon Islands is in the process of change with the curriculum being developed into a broader technological literacy approach comprising of technological knowledge, technological process, and technological and societal values. Thus, the development of teacher knowledge of technology and technology education and their technology education practices are crucial for the successful implementation of the new technology curriculum proposal.

The theoretical framework of this thesis is based on the interpretivist paradigm with a qualitative case study approach. A two-year study with eight secondary technology education teachers in the Solomon Islands was undertaken in 2005 and 2006. The teachers existing perceptions of technology and technology education, classroom practices and student learning in 2005 are described. The professional development programme undertaken in 2006 and its impact on the secondary school teachers' perceptions of technology and technology education, classroom practices, and student learning in technology education are also examined.

The preliminary inquiry in 2005 showed that the technology teachers in the Solomon Islands held narrow perspectives of technology and technology education, with views centring on narrow technical aspects. The teachers' 2005 classroom practices were very conservative with technical skills focussed teaching approaches fostered mainly rote learning, and their assessment was dominated by summative assessment foci. The 2005 findings were used as a basis for a professional development to prepare teachers to become more effective when teaching the proposed technology curriculum. A professional development intervention programme was undertaken in 2006. It was based on key professional development principles of teacher support and teacher reflection and sharing. It was on-going and was undertaken over time. A social constructivist learning model was used by the professional development provider to

help bring about teacher change. This programme built on the localised context and was crafted around best practices from other professional development models.

The study provides empirical evidence that the professional development intervention programme had a positive impact on the teachers' perceptions of technology and technology education, and teachers' teaching practices which changed from having a technical education focus to a technology education focus. There were strong links between teachers' perceptions and their classroom practices. When teachers developed robust knowledge about technology and technology education, and used appropriate technology education specific pedagogies they were able to successfully implement the new Solomon Island technology education curriculum. The positive impact of the professional development programme on teachers' understandings of the nature of technology and technology education, their classroom practices, and student learning demonstrate its effectiveness. The success of the professional development model justifies the recommendation for its wider use in other developing countries with similar contexts and situations to the Solomon Islands.

ACKNOWLEDGEMENTS

I would like to thank the following people for their contributions to the production of this thesis:

- To the Almighty God; the provider of all knowledge and wisdom, for sustaining me throughout this study;
- To my chief supervisor, Dr. Judy Moreland; thank you for your superb supervision, guidance and assistance with my work, and my most sincere thanks for your inspiration;
- To my second supervisor, Professor Alister Jones; thank you for your brilliant advice and direction in assisting me to establish a solid foundation in technology education on which this thesis is based;
- To Raewyn Oulton; thank you for your excellent secretarial support, and especially for your help and assistance during my study here at CSTER;
- To CSTER staff and colleagues at this centre; thank you for your professional assistance and friendship during my two years of study at CSTER; a special thanks to CSTER for the financial support provided for the PD intervention programme in the Solomon Islands.
- To the proof reading team Paula Williams, Jennifer Buckle; thank you for your time in proof reading this thesis and also for your great help with English;
- To the participants of this study, the Solomon Islands secondary school teachers; thank you for your cooperation and willingness to become part of this study, and for the valuable resources that you have provided for this study;
- To the New Zealand Government; thank you for the NZAID scholarship which made it possible for me to do this study at the University of Waikato;
- To the Solomon Islands Ministry of Education and Human Resources; thank you for your approval to conduct this study in the Honiara secondary schools in the Solomon Islands;
- To the International Students Office staff; thank you for your friendship and support and especially to Sonya, Sue, Mart and Huy Vu, for your excellent management of my scholarship;
- To my dearest wife Betty; thank you for your endless love, encouragement and support, and understanding during my study;

- To all my family members, brothers and sisters, and all the in-laws; thank you for your love and constant support and inspiration during my research study both at home and in New Zealand; a special thanks to my brother-in-law, Banabas Anga for the financial support provided through the Ministry of Education for the PD intervention programme in Honiara.
- To all my friends, and *wantoks* in Hamilton and abroad; thank you for your support and friendship during my study at the University of Waikato;

This research study would not have been possible without your cooperation and contributions.

DEDICATIONS

*This thesis
is dedicated to my dearest wife
Betty Sade*

*my father
Sade A. Molia
and beloved mother
Tosasai Sade*

*my brothers
Alick and Peter*

*and my Sisters
Margret, Rosie and Kerry*

Publications from this Thesis

Book Chapter

- Sade, D. (2008). Technology education development in the Solomon Islands. In R. Coll, & N. Taylor (Eds). *Science Education in Context: An International Examination of the Influence of Context on Science Curricula Development and Implementation*. (pp. 45-54). Sense Publisher, Netherlands.

Published Paper

- Sade, D., Moreland, J., & Jones, A. (2007). Technology education teacher development in the Solomon Islands: Enhancing teachers' perceptions and classroom practices. *Tenz conference 2007 papers booklet*. (pp. 46-55). Auckland, New Zealand.

Published Abstract

- Sade, D. (2008). Professional development of technology education teachers in the Solomon Islands: Enhancing teachers' perceptions and classroom practices in technology education. *Building pacific research capacity and scholarship 2008*. (p. 30). BRCSS Network, New Zealand.

Table of Contents

| | |
|---|------|
| Abstract..... | ii |
| Acknowledgements..... | iv |
| Dedications..... | vi |
| Publications from this thesis..... | vii |
| Table of Content..... | viii |
| List of Figures and Table..... | xv |
| 1: Introduction | 1 |
| 1.1 Introduction | 1 |
| 1.2 The Context of the Research Inquiry..... | 2 |
| 1.2.1 The Solomon Islands..... | 2 |
| 1.2.2 Education in Solomon Islands..... | 3 |
| 1.3 Rational for this Research Study..... | 8 |
| 1.4 Research Focus..... | 10 |
| 1.4.1 Research Outline..... | 11 |
| 1.4.2 Role of the Researcher..... | 11 |
| 1.5 Research Significance..... | 12 |
| 1.6 Overview of Thesis Chapters..... | 12 |
| 2: Literature Review | 14 |
| 2.1: Introduction | 14 |
| 2.2 Technology and Technology Education | 14 |
| 2.2.1 Definitions of Technology..... | 15 |
| 2.2.2 Types of Technology..... | 17 |
| 2.2.3 The Development of Technology Education..... | 23 |
| 2.2.4 Teachers’ Perceptions of Technology and Technology Education..... | 29 |
| 2.3 Curriculum Development Context..... | 32 |
| 2.3.1 Defining Curriculum Context..... | 33 |
| 2.3.2 Curriculum Development..... | 33 |
| 2.3.3 Teachers and Curriculum Decision Making..... | 34 |
| 2.3.4 Teachers’ Attitude to Curriculum Change..... | 35 |
| 2.3.5 Curriculum Development in the Solomon Islands..... | 35 |
| 2.4 Professional Development..... | 36 |

| | |
|---|-----------|
| 2.4.1 Professional Development and Curriculum Reform..... | 36 |
| 2.4.2 Professional Development Model..... | 37 |
| 2.4.3 Effective Professional development..... | 37 |
| 2.4.4 Professional Development in Technology Education..... | 39 |
| 2.4.5 Theoretical View of Learning for the Professional Development of Technology Education Teachers in the Solomon Islands..... | 40 |
| 2.4.6 Professional Development and Teacher Knowledge..... | 41 |
| 2.5 Summary of the Literature and Research Questions for this Thesis..... | 44 |
| | |
| 3: Methodology..... | 47 |
| 3.1 Introduction..... | 47 |
| 3.2 Methodological Paradigm for this Research..... | 47 |
| 3.3 Interpretivist Research Design..... | 49 |
| 3.3.1 Multiple Data Generation Methods..... | 50 |
| 3.3.2 Data Analysis..... | 57 |
| 3.3.3 Ethical Consideration..... | 57 |
| 3.3.4 Establishing the Quality of Qualitative Inquiry..... | 58 |
| 3.4 Research Design for the Thesis..... | 61 |
| 3.4.1 Multiple Data Generation Methods..... | 61 |
| 3.4.2 Data Generation Processes..... | 64 |
| 3.4.3 Data Analysis Methods | 65 |
| 3.4.4 Validity and Reliability..... | 66 |
| 3.4.5 The Role of the Researcher..... | 67 |
| 3.4.6 Ethical Issues for the Inquiry..... | 67 |
| 3.4.7 Research Participants..... | 68 |
| 3.5 Chapter Summary..... | 70 |
| | |
| 4: Teachers' Perceptions of Technology and Technology Education: 2005 Findings | 72 |
| 4.1 Introduction..... | 72 |
| 4.2 Teachers' Perceptions of Technology..... | 73 |
| 4.2.1 Technology as Artefacts..... | 73 |

| | | |
|-----------|---|-----------|
| 4.2.2 | Technology as Making Something..... | 74 |
| 4.2.3 | Technology as Applied Knowledge..... | 75 |
| 4.3 | Teachers' Perceptions of Indigenous Technology..... | 76 |
| 4.3.1 | Indigenous Technology as Traditional Ways of Doing Things..... | 77 |
| 4.3.2 | Indigenous Technology as Locally Made Artefacts..... | 77 |
| 4.3.3 | Indigenous Technology as the Use of Traditional Materials..... | 78 |
| 4.4 | Teachers' Perceptions of Technology Education..... | 79 |
| 4.4.1 | Technology Education as Hands-on Activity Education..... | 80 |
| 4.4.2 | Technology Education as Creative and Innovative Education..... | 81 |
| 4.5 | Teachers' Perceptions of the Value of Technology Education..... | 82 |
| 4.5.1 | Value of Practical Knowledge and Technical Skills in Technology Education..... | 83 |
| 4.5.2 | Value of Technology Education for Less Academic Students Exiting Secondary Education..... | 84 |
| 4.5.3 | Value of Technology Education as an Up-to-Date Education that Takes into Account New Changes in Society..... | 85 |
| 4.6 | Teachers' Classroom Technology Activities..... | 88 |
| 4.6.1 | Activities Based on Procedural Notes and Practical Follow up..... | 88 |
| 4.6.2 | Activities Based on Using Tools..... | 89 |
| 4.6.3 | Activities Based on the MoE Produced Documents..... | 89 |
| 4.7 | Teachers' Perceptions of their Teaching Strategies..... | 90 |
| 4.7.1 | Providing Student Notes with Practical Follow-up-based | 91 |
| 4.7.2 | Use of MoE Produced Documents | 92 |
| 4.7.3 | Other Views | 93 |
| 4.8 | Teachers' Reflections on Assessment of Students' Learning in Technology Education..... | 94 |
| 4.8.1 | On-going Form of Summative Assessment..... | 95 |
| 4.8.2 | One-off Form of Summative Assessment..... | 96 |
| 4.8.3 | Form influenced by the Curriculum Assessment Policy..... | 96 |
| 4.9 | Chapter Summary..... | 97 |
| 5: | Traditional Technical Classroom Practices: 2005 Findings..... | 99 |
| 5.1 | Introduction..... | 99 |

| | |
|---|------------|
| 5.2 Teachers' Teaching Documents..... | 99 |
| 5.2.1 Overview of Each Class..... | 100 |
| 5.2.2 Ministry of Education (MoE) Produced Materials..... | 101 |
| 5.2.3 Teachers' Individually Developed Teaching Materials..... | 104 |
| 5.2.4 Teachers' Learning Outcomes Considerations..... | 109 |
| 5.2.5 Working Procedures as Key Feature of the Lessons..... | 111 |
| 5.2.6 Summary of the Teachers' Teaching Documents..... | 113 |
| 5.3 Teaching and Learning Situations in the Technology Classrooms..... | 114 |
| 5.3.1 Factors Influencing the Teaching of Theoretical and Practical Lessons..... | 114 |
| 5.3.2 Narrow Technical Approach to Teaching and Learning Technology... | 117 |
| 5.3.3 Teaching Approaches..... | 120 |
| 5.3.4 Teachers' Assessment Practices..... | 123 |
| 5.3.5 Summary of the Teaching/Learning Situations in Technology Classrooms..... | 130 |
| 5.4 Key Findings of Chapter 5..... | 131 |
| 6: Teacher Professional Development: More than Technical..... | 135 |
| 6.1 Introduction..... | 135 |
| 6.2 Key Principles underpinning this Professional Development Programme.... | 136 |
| 6.2.1 On-going Nature of the Professional Development Programme..... | 136 |
| 6.2.2 Teacher Support Approach to Professional Development..... | 138 |
| 6.2.3 Role of the Professional Development Provider..... | 140 |
| 6.3 The Professional Development Programme..... | 141 |
| 6.3.1 Workshop One | 142 |
| 6.3.2 Workshop Two..... | 158 |
| 6.3.3 Workshop Three..... | 169 |
| 6.4 Chapter Summary..... | 184 |
| 7: Teachers' Changed Perceptions of Technology and Technology Education, and Classroom Practices: 2006 Findings..... | 185 |
| 7.1 Introduction..... | 185 |
| 7.2 Teachers' Changed Perceptions of Technology Education and Technology.. | 186 |

| | |
|--|------------|
| 7.2.1 Teachers' Changed Perceptions of Technology | 186 |
| 7.2.2 Teachers' Changed Perceptions of Technology Education | 191 |
| 7.3 Teachers' Changed Classroom Practices..... | 197 |
| 7.3.1 Teachers' Technology Lesson Planning | 197 |
| 7.3.2 Teachers' Change of Teaching Approaches | 209 |
| 7.3.3 Teachers' Assessment Practices..... | 218 |
| 7.4 Effects of Teachers' Change of Teaching Practices..... | 224 |
| 7.4.1 Teaching using the Design Process Teaching Approach with Other Classes..... | 225 |
| 7.4.2 Teachers' Decision to Continue with the Design Process Teaching Approach..... | 226 |
| 7.5 Factors in Hindering the Development of Teachers' Teaching Practices..... | 227 |
| 7.5.1 Need for Uniformity of the Project to be Mass-produced..... | 227 |
| 7.5.2 Time and Monetary limits..... | 228 |
| 7.5.3 School-Based Assessment and External Examination Requirements... | 229 |
| 7.6 Chapter Summary..... | 230 |
| | |
| 8: Impacts on Students' Learning..... | 232 |
| 8.1 Introduction..... | 232 |
| 8.2 Students' New Learning Experiences..... | 232 |
| 8.2.1 Teachers Classes selected in 2006..... | 233 |
| 8.2.2 Students' Learning Experiences in Anthony's Class..... | 234 |
| 8.2.3 Students' Learning Experiences in Timmy's Class..... | 237 |
| 8.2.4 Students' Learning Experiences in Zebedee's Class..... | 246 |
| 8.2.5 Students' Learning Experiences in Ronald's Class..... | 251 |
| 8.2.6 Students' Learning Experiences in Gilson's Class..... | 254 |
| 8.2.7 Students' Learning Experiences in Richard's Class..... | 256 |
| 8.3 Chapter Summary..... | 257 |
| | |
| 9: Discussion of the Research Findings..... | 259 |
| 9.1 Introduction..... | 259 |

| | |
|--|------------|
| 9.2 Teachers' Limited Understandings of the Nature of Technology and Technology Education and Teachers' Conventional Technical Teaching Practices in 2005..... | 260 |
| 9.2.1 Teachers' Limited Understandings of Technology and Technology Education..... | 261 |
| 9.3.2 Teachers' Conventional Prescriptive Teaching Practices..... | 267 |
| 9.3 The Impact of the Professional Development Programme | 273 |
| 9.3.1 Effects of the Key Characteristics of the Professional Development Programme | 274 |
| 9.3.2 Impacts on Teachers' Perceptions of Technology and Technology Education..... | 277 |
| 9.3.3 Impacts on Classroom Practices..... | 280 |
| 9.3.4 Impacts on Students' Learning Experiences in Technology Education..... | 288 |
| 9.3.5 Factors Hindering Teachers' Teaching Practices in Technology Education..... | 291 |
| 9.3.6 Effects of Effective Professional Development Programme | 293 |
| 9.4 Chapter Summary..... | 294 |
| | |
| 10: Conclusions and Implications: Towards a Professional Development Model for Technology Education Teachers in Developing Countries..... | 296 |
| 10.1 Introduction..... | 296 |
| 10.2 Enablers and Constrains to PD in the Solomon Islands..... | 296 |
| 10.3 Articulating a PD Model for Technology Education in the Solomon Islands..... | 298 |
| 10.4 Implications of the Research Findings..... | 306 |
| 10.5 Implication for Future Research..... | 312 |
| | |
| References..... | 313 |
| | |
| Appendices..... | 322 |
| Appendix A - The Research Study Plan Timeline | 323 |
| Appendix B - Application for Ethics Approval..... | 324 |

| | |
|--|-----|
| Appendix C - The Initial Interview Questions | 329 |
| Appendix D - Observation of Technology Teaching Approaches Format..... | 331 |
| Appendix E - Ministry of Education Letter..... | 332 |
| Appendix F – Letter of Consent..... | 333 |
| Appendix G - Teachers’ Backgrounds..... | 336 |
| Appendix H- Screws and Screwing Notes | 337 |
| Appendix I – Orthographic Drawing..... | 339 |
| Appendix J – Claw Hammer Notes..... | 340 |
| Appendix K - Raymond’s Photocopied Notes | 341 |
| Appendix L - School Backgrounds..... | 343 |
| Appendix M - Technology Education Questionnaire Sheet..... | 345 |
| Appendix N - Definitions of Technology..... | 347 |
| Appendix O - Rest of the teachers’ technology lesson planning..... | 348 |
| Appendix P –Observation Notes and Analysis..... | 358 |

Lists of Figures and Tables

Pages

Chapter One

Figure

| | |
|-----------------------------------|----|
| Figure 1.1 Research timeline..... | 11 |
|-----------------------------------|----|

Chapter Two

Figures

| | |
|---|----|
| Figure 2.1 Diagrammatic definition of technology and technology practice, incorporating three aspects of technology; cultural, organisational, and technical..... | 17 |
|---|----|

Chapter Three

Table

| | |
|------------------------------------|----|
| Table 3.1 Teacher backgrounds..... | 69 |
|------------------------------------|----|

Chapter Four

Tables

| | |
|---|----|
| Table 4.1 Teachers' perceptions of technology..... | 73 |
| Table 4.2 Teachers' perceptions of indigenous technology..... | 76 |
| Table 4.3 Teachers' perceptions of technology education..... | 80 |
| Table 4.4 Value of technology education in the Solomon Islands..... | 83 |
| Table 4.5 Summary of teachers' perceptions..... | 87 |
| Table 4.6 Categories of classroom technology activities..... | 88 |
| Table 4.7 Teachers' perceptions of their teaching strategies | 91 |
| Table 4.8 Summary of teachers' classroom technology activity and teaching strategies..... | 94 |
| Table 4.9 Teachers' reflections on assessment | 95 |
| Table 4.10 Summary of teachers' perceptions of assessment practices..... | 97 |

Chapter Five

Figures

| | |
|--|-----|
| Figure 5.1 Photocopied notes from MoE produced textbooks..... | 102 |
| Figure 5.2 A Form Two technical drawing exercise..... | 103 |
| Figure 5.3 Anthony's lesson outline | 105 |
| Figure 5.4 Students' paper funnel projects in Anthony's class | 106 |
| Figure 5.5 Gilson's lesson on identifying the values of resistors..... | 106 |
| Figure 5.6 Isometric view of Richard's file tray design..... | 107 |
| Figure 5.7 Student's work in Richard's class..... | 108 |
| Figure 5.8 Step-by-step procedure for joining sheet metal with rivets..... | 112 |
| Figure 5.9 Lesson on steps to construct rebate joint as outlined in the Industrial Arts Form Two textbook..... | 113 |

Tables

| | |
|--|-----|
| Table 5.1 Class overview..... | 100 |
| Table 5.2 Teachers' lesson sources..... | 108 |
| Table 5.3 Teachers' learning outcomes..... | 110 |
| Table 5.4 The teacher participants' teaching timetable for teaching Industrial Arts and Design Technology..... | 115 |

Chapter Six

Figures

| | |
|--|-----|
| Figure 6.1 Research inquiry structure | 141 |
| Figure 6.2 Example lesson plan format..... | 149 |
| Figure 6.3 Programme of work format..... | 151 |
| Figure 6.4 Ronald’s view of the new teaching approach..... | 160 |

Tables

| | |
|--|-----|
| Table 6.1 Professional development structural programme overview..... | 137 |
| Table 6.2 Overview of the sessions of Workshop One..... | 142 |
| Table 6.3 Evaluation of the overall content and length of time of Workshop One.... | 153 |
| Table 6.4a Relevance evaluation of Day One sessions of Workshop One..... | 155 |
| Table 6.4b Relevance evaluation of Day Two sessions of Workshop One..... | 155 |
| Table 6.5 Overview of the sessions of Workshop Two..... | 158 |
| Table 6.6 Evaluation of the overall content and sharing time of Workshop Two..... | 164 |
| Table 6.7 Teachers’ evaluation on the relevance of Workshop Two sessions..... | 166 |
| Table 6.8 Sessions of Workshop Two that teachers gained most from..... | 167 |
| Table 6.9 Overview of sessions of Workshop Three..... | 170 |
| Table 6.10 Summary of teacher reflections in Workshops Two and Three..... | 174 |
| Table 6.11 Aspects teachers found easy to implement and difficulties encountered. | 176 |

Chapter Seven

Figures

| | |
|---|-----|
| Figure 7.1 Zebedee’s lesson plan..... | 199 |
| Figure 7.2 Zebedee’s programme of work..... | 201 |
| Figure 7.3 Anthony’s lesson plan..... | 202 |
| Figure 7.4 Anthony’s programme of work..... | 204 |
| Figure 7.5 Timmy’s lesson plan..... | 205 |
| Figure 7.6 Timmy’s programme of work..... | 207 |
| Figure 7.7 Some of Zebedee’s Form Two students’ products..... | 213 |
| Figure 7.8 Photo of Anthony’s Form Five students’ dust brushes and a pan..... | 213 |
| Figure 7.9 Timmy’s Form Two students’ group artefacts..... | 214 |
| Figure 7.10 MoE assessment format..... | 222 |
| Figure 7.11 Zebedee’s project assessment criteria..... | 223 |
| Figure 7.12 Timmy’s project assessment criteria..... | 224 |
| Figure 7.13 Sample of Zebedee’s Form Four students’ mass produced stools..... | 228 |
| Figure 7.14 Richard’s Form Two students’ work..... | 229 |
| Figure 7.15 Gilson’s Form Five students’ work..... | 230 |

Tables

| | |
|---|-----|
| Table 7.1 Summary of 2005 and 2006 findings of teachers’ perceptions of technology..... | 191 |
| Table 7.2 Summary table on 2005 and 2006 findings of teachers’ perceptions of technology education..... | 196 |

Chapter Eight

Figures

| | |
|--|-----|
| Figure 8.1 James’ design of the coconut scraper..... | 235 |
| Figure 8.2 Anthony’s student working on his coconut scraper project..... | 236 |
| Figure 8.3 First sample of the students’ calendar..... | 241 |

| | |
|--|-----|
| Figure 8.4 Second samples of the students' calendar | 242 |
| Figure 8.5 Timmy's students using computers..... | 244 |
| Figure 8.6 Students' self assessment format in Timmy's class..... | 246 |
| Figure 8.7 Paul's sketched ideas..... | 247 |
| Figure 8.8 Paul's working drawings..... | 248 |
| Figure 8.9 A student welding his stool project..... | 249 |
| Figure 8.10 Paul's self assessment of his class project..... | 250 |
| Figure 8.11 Samson's sketched ideas..... | 251 |
| Figure 8.12 Willie's preliminary sketch and working drawings..... | 252 |
| Figure 8.13 Two students working with chisels..... | 253 |
| Figure 8.14 Two students working on their electronic projects..... | 255 |
| Figure 8.15 A student using the saw to cut plywood to required size..... | 256 |

Table

| | |
|---|-----|
| Table 8.1 Overview of teachers' class selections in 2006..... | 233 |
|---|-----|

Chapter Nine

Figure

| | |
|---|-----|
| Figure 9.1 Student products from prescriptive and open-ended teaching Approaches..... | 286 |
|---|-----|

Chapter Ten

Figures

| | |
|--|-----|
| Figure 10.1 PD Model for developing technology education teachers in developing countries..... | 299 |
|--|-----|

CHAPTER ONE

INTRODUCTION

1.1 Introduction

This study explores the impact of a specially designed technology education professional development programme for traditional technical education secondary teachers to assist with the implementation of technology education in the Solomon Islands. The Solomon Islands is a developing country and just before the commencement of this study had undergone two years (2000 and 2001) of civil unrest. Out of the civil unrest, major curriculum reform was undertaken by the Ministry of Education in 2004 and 2005. Technology education was one of the subjects included in the reform. Changes made to the curriculum reflect much of technology education curriculum reform that has recently occurred in other countries. Contributing to the difficulties of curriculum reform in the Solomon Islands is its developing nature, the backdrop of civil unrest and the geographic spread of its many islands. This study took up the challenge of researching professional development for technology education in the Solomon Islands. The aim of this study was to develop a professional development programme that took into account of the local context, teachers' views, and best practices which focussed on enhancing teacher knowledge to influence curriculum implementation.

This chapter provides an introduction to the thesis. It begins with a description of the context in which this study was conducted. This is followed by details of the technical education system and the development of the technology education curriculum in the Solomon Islands. The rationale and theoretical framework for the study is presented next, followed by the focus of the research along with the research questions, the research outline and role of the researcher. A discussion of the significance of this study follows, and the chapter concludes with an overview of the thesis chapters.

1.2 Context of the Research Inquiry

1.2.1 Solomon Islands

History

The Solomon Islands is a small island nation in the Pacific region. The main inhabitants of the Solomon Islands are mostly Melanesians (93%) with a small number of Polynesians (1.5%) and Micronesians (1.5%), and a few others. Although the origin of the present Melanesian inhabitants is uncertain, archaeological and linguistic evidence suggests that the Solomon Islands was probably settled between four and five thousand years ago by Austronesian, Neolithic people from South East Asia. The first European contact was made in 1568 by the Spanish explorer Alvaro de Mendana, and many of the islands in the Solomon Islands bear Spanish names because of Mendana's Spanish heritage (Honan & Harcombe, 1997).

Politics

The Solomon Islands became a British Protectorate in 1893, with the Santa Cruz group added in 1899, and the Shortland group transferred by treaty from Germany to Great Britain in 1900. The Solomon Islands was governed by Great Britain until 1978, after which the country became independent. As an independent nation, the Solomon Islands has taken up a self-governing role and has adopted a democratic system of government. Its constitution established a modified Westminster form of government with the British monarch as the official head of state. The head of state is represented in the Solomon Islands by a Governor General, who is a Solomon Island citizen appointed on the recommendation of the Solomon Islands parliament (Honan & Harcombe, 1997).

Geography

The Solomon Islands is located among the other Melanesian island nations within the South Pacific region. The Solomon Islands consists of six major islands and approximately 992 smaller islands, atolls and reefs, stretching over approximately 1,500 square kilometres, with a land area of some 28,369 square kilometres. The climate is maritime tropical with heavy rainfall and an average temperature of 27 degrees Celsius and periodic maritime cyclones (Honan & Harcombe, 1997).

Honiara, the capital of the Solomon Islands, is located on the main island of Guadalcanal province, and has a population of about 60,000 (Kudu, 2001). The capital is the centre for the government and commerce, as well as the international airport and main seaport. The east and west of Guadalcanal, as well as smaller provincial islands, are isolated with some islands only visited by ship once a month. Most provincial islands have an air service several times a week, and a regular shipping service. The main industries in the country are canned fish, agro-processing, timber, copra, palm oil and cocoa which are a major part of the country's economy (World Bank Report, 1993).

The country's population is estimated to be about 409,000, and is increasing at a rate of 2.8% per annum with some 47% of Solomon Islanders under the age of 15 years. These unusual demographics have resulted in an alarming unemployment rate, especially amongst the youth (Kudu, 2001). There are nine main provinces in the Solomon Islands and about 86 different languages across the country, although Solomon pidgin is the main spoken language, and English is the official language (Honan & Harcombe, 1997).

1.2.2 Education in Solomon Islands

Prior to European contact, most Solomon Islanders considered education to be an internal issue in which teaching and learning were conducted within the traditional Solomon Islands societal context. Education was perceived to involve parents and elders teaching youth the precautions and norms of life. This traditional education in the Solomon Islands served to prepare young people for life through participation in community tasks amidst their own social, political and physical environment (Kii, 1994).

During the missionary era, the influence of Christianity brought about many changes and had a great impact on the lives of most Solomon Islanders. In particular, the early Christian missionaries brought education to the country. Upon becoming a British Protectorate, the Government of the Solomon Islands, along with the churches, took an active role in the provision of education in the Solomon Islands (Groves, 1939). In 1946, the first Department of Education was established and from time to time the government made proposals for educational development in cooperation with the missionaries (Kii,

1994). This collaborative phenomenon is still continuing and respected by all parties as far as the education development in the Solomon Islands is concerned.

The current formal education system in the Solomon Islands consists of three education levels: primary, secondary, and tertiary. Primary education in the Solomon Islands begins with the preparatory class, and goes up to Standard Six, with secondary education beginning from Form One, and going through to Form Five, with some schools going through to Forms Six and Seven. The College of Higher Education is the government's only tertiary institution in the country, apart from regional Universities that Solomon Islanders attend after their secondary schooling. The University of the South Pacific's extension Centre in Honiara also offers tertiary courses for students after completion of secondary schooling.

Technical Education

Technical education has always been a part of the indigenous education system in the Solomon Islands, as it is concerned more with the development of life skills basically needed for survival. This traditional education was rarely institutionalised as it was seen as the sole responsibility of the whole community. Therefore, the adaptation of an institutionalised education system under the guidance of a single teacher was seen as a Western intervention (Kii, 1994). The year 1965 was the beginning of this western intervention era, when Dr. J.M. Carswell, who was then the Deputy Director of Technical Education in New South Wales, Australia, established the first technical college in the Solomon Islands, known as Honiara Technical Institution (HTI). Although this technical institute offered trade and vocational courses, it also had its shortcomings. The focus was basically on developing trade skills for a paid job, and only a few Solomon Islanders who had advanced through to complete their secondary education actually got this education privilege (SITC, 1981).

It has always been the intention of the Solomon Islands government that technical education be included in the post-colonial education system, and that the curriculum of secondary schools include practical subjects tailored specifically to suit the lifestyle in

the urban and rural Solomon Islands. In 1974, prior to the Solomon Islands' independence, a new education policy paper (Education for What? 1974) was written to address the foreign curriculum which was used in the secondary schools in the Solomon Islands. The policy statement emphasized the notion that curriculum development should take into account the Solomon Islands context when developing curricula for secondary schools. The four aims set for the curriculum were (a) to complete the basic education begun in the six years of primary; (b) to equip the child for young adult situations and responsibilities; (c) to provide a basis for technical learning and employment in agriculture, trade and industry; and (d) to develop interests and skills with roots in the cultural heritage (CDC, 1983). The rationale for this choice was that those who graduated from the secondary schools would feel that they were well equipped with knowledge and skills relevant for life in the Solomon Islands (Kii, 1994).

Another development in technical education was the establishment of rural and vocational training centers by various church authorities to provide technical education for primary school leavers (Grade Six) who are not given space in Form One. However, the number of secondary school dropouts has been on the rise every year at an alarming rate, due to there being few senior secondary schools available in Solomon Islands. With not much choice, these vocational training centres have to take in the secondary school leavers as well. These institutions offer vocational training in various trades and award certificates at the end of the courses. The graduates are expected to use the skills acquired to earn a basic living in the rural community in Solomon Islands.

In the search for the root of the ethnic tension in the Solomon Islands, most believed that the education policies of the Ministry of Education are to be blamed (MoE, 2004), as it has been noticed that the education policies and practices seem to have so much bias towards the academic education than technical education, and apparently unemployment, has been on the rise. This forced the national government, through the Ministry of Education, to set a task force to revisit its policies and practices in order to strike a balance between academic and technical education. Consequently, new policies were

developed to provide that balance between the academic and technical education (MoE, 2004).

Technology Education

The two existing technology education curricula used in the secondary schools in the Solomon Islands are imported from abroad. The first is the *Technology A & B* (USP, 1998) developed by the University of South Pacific in Fiji, and is currently introduced in the seventh form as a foundation level course for students interested in taking up engineering courses at university. The other technology programme is the *Design Technology Prescription* (SPBEA, 2002) which was developed by the South Pacific Board of Educational Assessment (SPBEA), also based in Fiji, and is offered in the sixth form. This curriculum is focussed mainly on the design process approach.

A new Technology syllabus for Forms One to Five was developed during a recent curriculum reform programme undertaken by the Ministry of Education in the Solomon Islands, in 2004 and 2005. The development of the Form One to Five technology syllabus is basically to enhance the continuity of learning of technological concepts and practices, from Form One through to Form Seven. This new syllabus is not a new learning area in the Solomon Islands curricula, but rather an upgrading of the current Forms One to Five Industrial Arts syllabus to include broader technological concepts and practices. The new technology curriculum is taking on board the issues raised in the new technical education policy *Education for Living* (MoE, 2004).

Aim of the New Technology Curriculum

The technology curriculum aims to develop students:

- Technological knowledge and understanding;
- Skills competency and confidence in solving technological problems through the technological process; and
- Awareness and understanding of the interrelationship of technology and society.

The new technology curriculum combines the concepts of technological literacy with the technological design process. The aim of the new technology curriculum is to develop technological literacy through an ongoing learning process and solve problems through the design process approaches. The design process involves students in identifying problems, needs, or opportunities in real life situations within the Solomon Islands context. The ultimate aim of the technology curriculum is to educate students to become knowledgeable and technically skilful, and to be aware of the social impacts and effects of technology and society both within the Solomon Islands context and globally (MoE, 2005).

Key Features of the New Technology Curriculum

- Technological Knowledge and Understanding

Knowledge is an important aspect of the technological activities. Students need to utilise their technological knowledge and transform other knowledge in order to carry out the technological activities. It is important that students have an understanding of safety and general technological practices, technological principles and processes within the different communities of technological practices in which the technological activity is performed. Students also need to understand the uses and operations of the range of technologies in which they are involved in carrying out the technological activities. Furthermore, students also need to understand the strategies required for communicating, promoting and marketing of the technological ideas and outcomes in regard to the task at hand (MoE, 2005).

- Technological Process

Technological activity begins with an investigation. This means that students have to investigate or identify a problem, need, or an opportunity, for which a possible technological solution is designed or generated. When a solution is selected, then it is constructed and produced. After completion, the technological solution is reviewed and evaluated according to the design brief or specifications. After the technological solution meets the design specifications, it is then presented for marketing. The students'

technological capability and competency is enhanced through the design process and technical skills aspect of the technology curriculum (MoE, 2005).

- Technological and Societal values

It is important that students understand that technology is not neutral, but an integral part of society. Therefore, it is important that students are aware of the factors, such as people's beliefs and attitudes, that influence the technological developments and the impact of technology on people and environment (MoE, 2005).

As the Solomon Islands community is divided into urban and rural communities, the specific context in which the technological activities are developed should be appropriate to either the urban or rural community (MoE, 2005). This new curriculum also embraces the four basic knowledge domains as being conceptual, procedural, technical and societal. These domains are considered the basis for teaching and learning in technology education. It is the development of this new technology education curriculum that provides the thrust for this research inquiry.

1.3 Rationale for this Research Study

Technology education is a newcomer in the curriculum arena worldwide in both the developed and developing countries. Considerable growth in research into this area of technology and technology education in the latter part of the last century has been evident. However, very little has been done in developing countries such as the Solomon Islands. Many recent studies in technology and technology education focussed on teachers' concepts and classroom experiences in teaching and learning in technology education have occurred in developed countries such as United States, United Kingdom, New Zealand, and Australia. In addition, the contexts of these studies are quite different from the context of a developing country, such as the Solomon Islands where this research inquiry is focussed. Therefore, doing this research in the Solomon Islands is both important and timely in preparation for the implementation of the new technology curriculum in the Solomon Islands.

The Curriculum Centre at the Ministry of Education in the Solomon Islands has recently undertaken a major curriculum reform, which prompted the curriculum developers to instigate some significant changes to the school syllabuses in the Solomon Islands. Consequently, a new curriculum which is now known as Technology was developed to replace the existing Industrial Arts syllabus. These changes have created considerable opportunities for research, mainly to inform the stakeholders involved in one way or another, particularly in technology education. This research study has a professional development aspect, where teachers were empowered to make curriculum decisions and to be creative and innovative. They were encouraged to be more self-directed and independent in their learning (Bell, 2005; McGee, 1997). The guidelines for the professional development programme in this study were based on the findings of Bell and Gilbert's (1994) research. These included the personal, social and professional needs of teachers and took into account teacher support, feedback and reflection principles.

Past research on teachers' perceptions of technology and technology education in the Solomon Islands has indicated that teachers have a narrow concept of technology and technology education (Liligeto, 2001; Sade, 2002). Therefore, the objective of this research inquiry was to expand teacher's technological knowledge to become more competent technology classroom practitioners. Jones and Compton (1998) suggest that a professional development programme in technology education that considers the importance of teachers' developing a robust concept of technology education, technological pedagogy and technological practices would help with effective technology curriculum implementation and the development of successful technological classroom practitioners. The professional development programme in this research study provided teachers with opportunities to construct technological knowledge by reflecting on both their own and others' concepts of technology and technology education, technological pedagogy, and technological practices.

The use of centrally developed programmes is the usual approach to teacher professional development in the Solomon Islands because of its geographical setting with many scattered islands and great isolation. Bell (1993) points out that meaningful teacher

change does not normally occur with a top-down dissemination approach for professional development. Rather a professional development model based on interaction and collaboration is more successful. Professional development with these characteristics was found to be effective for bringing about meaningful long-lasting changes in teaching practice (Bell, 1993). Therefore, part of this research aimed at investigating the effects the professional development programme had on teachers' classroom practices in technology education.

This research inquiry takes a social constructivist view of learning, where knowledge is socially constructed and situated. With this theory, knowledge is built in social interactions between participants and meaning is negotiated between those participating (Guba & Lincoln, 1989; Resnick, 1991). Learning and the contexts in which the learning takes place cannot be separated (Hennessy, 1993; Resnick, 1991). The theoretical perspective of this research is grounded on a social constructivist view, which then helped to form the methodological approach and methods selected.

1.4 Research Focus

This research study focussed on professional development and the effect it had on influencing technology education teachers' concepts of technology and technology education, and their classroom practice. The aim of this study was to develop and explore the impact of a technology education professional development programme that took into account the localised context and teachers' existing views and practice. Therefore, the objectives of this study were to explore:

1. Teachers' existing views of technology and technology education, and their current classroom practice;
2. The development of a professional development programme that takes account of the (a) localised context, (b) teachers' views, and (c) best practice;
3. The effects and influence a professional development programme has on teachers' concepts of technology and technology education; and
4. The impact of teachers' developing technology education understandings and practices in student learning.

1.4.1 Research Outline

The research study tracked the inquiry process over a period of two years (2005 and 2006), and was undertaken in two phases (see Figure 1.1: Research timeline), with a six month interval between each phase. The first phase of the research study took about two months, one school term. The study took four months in the second phase. The professional development programme was organised into three block workshops with sufficient time given to teachers between each workshop for classroom practice (see Figure 1.1). The professional development programme was developed by the researcher, who also delivered and directed it.

Figure 1.1
Research timeline

Phase 1 – Preliminary Inquiry – A two month period (September - October 2005)

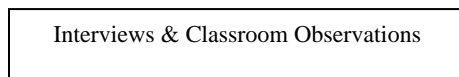

Phase 2 – Professional Development and Classroom Practice – A four month period (July - October 2006)

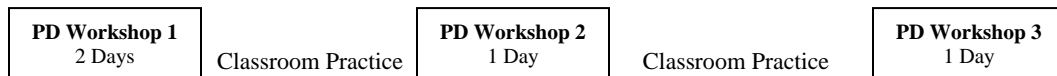

1.4.2 Role of the Researcher

The researcher is a local Solomon Islander, and has been actively involved in the development of the new technology education curriculum in the Solomon Islands. The technology education curriculum reform was undertaken by a team of Industrial Arts teachers, under the direction and leadership of the researcher. This research was undertaken prior to the implementation of the new curriculum. Therefore, the role which the researcher took was to provide eight secondary school technology education teachers with a professional development programme to prepare them for the implementation of technology education.

1.5 Research Significance

There has been very little research undertaken on professional teacher development programmes in the Solomon Islands, with very little in specific curriculum areas. This research is the first inquiry to be documented on professional development teachers of a specific curriculum area. Therefore, this research is a significant piece of documentation from which valuable recommendations can be drawn to assist respective stakeholders (the Funding Agencies, the Technology Education teachers, Teachers' College and the Curriculum Department of the Ministry of Education) who have been associated with the overall curriculum reform programme. The resulting data will be a useful source of feedback information, for providing guidelines to policy makers at the Ministry of Education to plan future professional development programmes, for the enhancement of the implementation process of technology education, as well as other curricula in the Solomon Islands. This research will also contribute to the wider body of research, as it will provide a perspective from a context, which differs from those of well-resourced developed countries. This research inquiry is a classroom-based inquiry focussed on enhancing teachers' concepts of technology and technology education, and their classroom practices in technology education. As Jones (2001) points out, more classroom-based research is required in technology education, and it must be focussed on student and teacher learning in technology. Hence, the outcome of this research study will contribute to the field of classroom-based research and also to the professional development research in technology education internationally.

1.6 Overview of Thesis Chapters

Chapter Two reviews the literature related to technology and technology education, curriculum context and professional development. Chapter Three discusses the methodology used for undertaking this research study. Chapter Four and Chapter Five discuss the findings of the preliminary inquiry undertaken in 2005. Chapter Four examines the teachers' existing perceptions of technology and technology education, and the teachers' classroom practices are discussed in Chapter Five. Chapter Six discusses the teacher professional development intervention programme undertaken in 2006. The findings of the impact of the professional development intervention programme are

discussed in Chapter Seven. Chapter Eight examines the extent to which teachers' changed perceptions of technology and technology education and their changed classroom practices impacted on student learning. Chapter Nine presents the discussion. A conclusion and implications of this research are presented in Chapter Ten.

CHAPTER TWO

LITERATURE REVIEW

2.1 Introduction

Chapter One introduced the thesis. It described the setting of the Solomon Islands to provide the context in which this research inquiry was undertaken. This included the general education system and technology education development. The focus of this research inquiry was also introduced including the rationale of this study, the theoretical framework and the research aims and objectives.

This chapter comprises a review of relevant literature. The literature review, which establishes the context for this thesis is divided into three main parts. The first part provides a discussion of definitions of the concepts of technology. This is followed by a discussion of the nature of technology education and development of technology education trends internationally. This is followed by the exploration of teachers' perceptions of technology education in relation to curriculum development and implementation. The second part looks at the factors influencing curriculum development, and teachers' attitudes to curriculum changes and implementation. The third examines the literature related to effective professional development (PD) in general followed by specific approaches to PD in technology education. The final section of the chapter provides a summary of the literature reviewed, and relates these findings to the research questions itemised in Chapter One.

2.2 Technology and Technology Education

This section discusses the aspects related to technology and technology education. Section 2.2.1 discusses a range of views on definitions of technology and types of technology are discussed in section 2.2.2. This is followed by a discussion of the development of technology education in section 2.2.3 and section 2.2.4 discusses the views teachers' hold on technology and technology education.

2.2.1 Definitions of Technology

Although attempting to define technology is a recent phenomenon, technology itself is as old as humanity. People have been using technology since their existence to manipulate and seek control over their environment (Dyrenfurth, 1984). Adam (1993) explains that the word technology is derived from the Greek words *tekhne*, which means art or skill, and *logia*, which means science or study. Lux (1983) states that, “technology is a praxiological knowledge,” (p.1). Over the past decades, many scholars have been involved in studying technology in an attempt to understand better the term. Hansen and Froelich (1994) confirm that philosophers, sociologists, historians, and teachers have continued to study this subject in search of a specific definition, and yet one accepted definition remains elusive. Broad definitions of technology have been discussed by Cutcliff (1981), Dyrenfurth (1990), Gardner (1994), Mitcham (1994) and Pacey (1983).

Some see technology as the end product of human engineering endeavours. Johnson (1989), for example, defines technology as the “application of knowledge, tools, and skills to solve practical problems” (p.2). Such authors see and view technology as the work of engineers, inventors and technologists when they apply knowledge, sometimes from scientific theories or other sources of knowledge and sometimes from experience, to create and commercialise devices and systems to meet human goals (Naughton, 1992).

Other authors view technology as the result of human influence and control. Mitcham (1994) argues that technology is more than engineering and incorporates philosophy, since all technology has been developed by people to satisfy human needs and wants. Cutcliff (1981) states that:

Technology is a social process in which abstract economic, cultural, and social values, shape, develop and implement specific artefacts and techniques that emerge from the distinct technical problem-solving activity called engineering which is embedded in that process. (p.36)

This view of technology is consistent with the definition of technology used in some curriculum documents such as the recent New Zealand Technology curriculum document, which defines technology as:

Technology is intervention by design: the use of practical and intellectual resources to develop products and systems (technological outcomes) that expand human possibilities by addressing needs and realising opportunities. Adaptation and innovation are at the heart of technological practice. Quality outcomes result from thinking and practices that are informed, critical, and creative (Ministry of Education, 2007, p.32).

According to these more holistic definitions, technology cannot be divorced from its creators. Mitcham (1994) points out that there are four dimensions of technology. First there is technology as an artefact, such as tools, machines, manufactured products and so forth. Second, technology can be viewed as an activity or process such as inventions or making, using, designing, and problem-solving. Third, technology may be seen as knowledge, scientific and engineering, as well as other relevant knowledge. Last, technology as volition, which incorporates a human and social dimension. Wright (1996) supports these views and articulates the view that technology is a subject that involves “human knowledge that uses tools, materials and systems to produce artefacts (human-made things) and perhaps other unintended outputs (pollution, scrap, etc.), to modify or control the natural and human-made environments” (p.2). de Vries (2005) also echoes similar views and defines technology as “the human activity that transformed the nature environment to make it fit better with human needs, thereby using various kinds of information and knowledge, various kinds of natural (materials, energy) and cultural resources (money, social relationships, etc.)” (p.11).

Several authors have indicated that technology and technological practice is very much a part of society. Pacey (1983) sees technology and technological practice in three dimensions: a cultural aspect, an organisational aspect, and a technical aspect (Figure 2.1). Burns (1997) explains that the cultural aspect takes into account people’s values and beliefs, while the organisational aspect takes into account the way in which each society manages technological development, and the technical

aspect takes into account the knowledge and skills which contribute to technological problem-solving. According to Pacey's (1983) model for defining technological practice, 'liveware,' (people) as well as hardware (man-made) needs to be included in the definition of technology. He further adds that technology is not only technical in nature, but also influenced by culture and the role of people and organisations in societies, and vice-versa.

Figure 2.1:
Diagrammatic definition of technology and technology practice, incorporating three aspects of technology; cultural, organisational, and technical

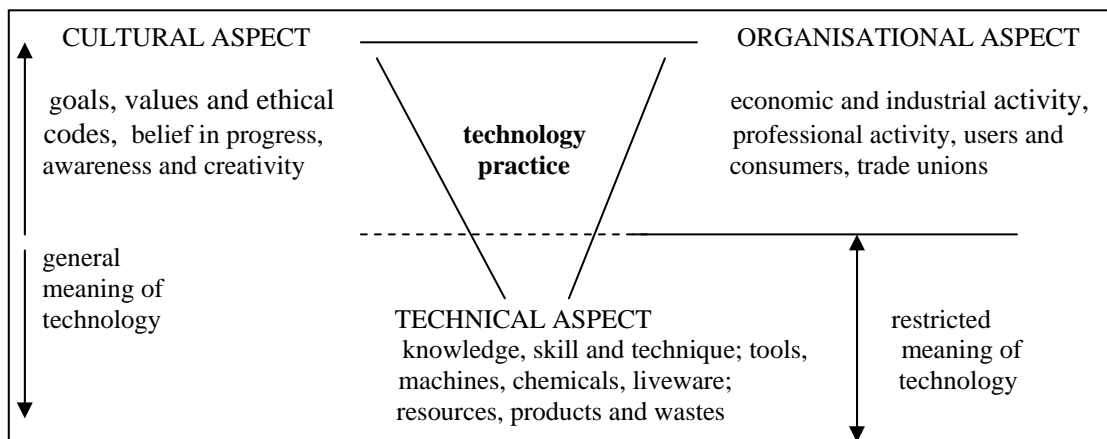

Source: Pacey, 1983, p.6.

Hence, technology seems to be a complex and difficult term to define. The broad definitions of technology have revealed the difficulty many authors have encountered in trying to clearly define a complex holistic concept. This, Henson and Froelich (1994) believe, occurs since people conceptualise technology from different viewpoints, with their concepts of technology formulated or based on their own prior experiences. Layton (1993) explains that the holistic nature of technology, as a “seamless web of interactive components in a complex socio-technical system” (p.26).

2.2.2 Types of Technology

Technology is a familiar term that is now widely used by many people, including children. Views of technology are compounded by the fact that the term has become

a household word, and has been used interchangeably with other similar terms. Custer (1995) argues that although the use of the term technology in the community at large appears to be a relatively simple concept, it is not so. He adds that the general public has a range of unsorted, mixed views of technology and even the academic community has failed to reach consensus. However, de Vries (2005) argues that understanding technology from a philosophical point of view would assist in reaching a consensus.

The view of technology used in this thesis is based on the work of both Mitcham (1994) and de Vries (2005) and comprises technology as artefact; technology as knowledge; technology as activity or process; and technology as volition, and organisation. Cluster (1995) comments that to better understand the term technology, the concepts of technology as artefact, knowledge, activity or process, and volition with both the human and social dimensions, also need to be considered. These dimensions enable the concept of technology to be much clearer, more complete, and simpler to understand, although that complexity is acknowledged as technology moves from artefacts through volition. The views of these dimensions of technology are now discussed in turn.

Technology as Artefact

A number of authors view technology as hardware or artefact. Mitcham (1994) describes technology in terms of all products fabricated by human engineers, and DeVore (1980) likewise acknowledges that technology is made up of physical elements invented or created by human beings (see also, Gardner, 1994). Typically, this means that technology is seen to consist of machines such as computers, lasers, supersonic aircraft, and so forth (Wright, 1996).

According to McRobbie et al. (2000), pre-service teachers view technology in this simple manner, as a product or generic thing, and Symington (1987) points out that this may be related to media portrayals of technology as complex sophisticated machinery such as lasers, computers, and robots. The view of technology as artefacts

becomes a common name, even for children, as people's immediate encounter with technology is through technical artefacts (de Vries, 2005).

de Vries (2005) explains that artefacts have a part in teaching and learning about technology. He adds that students can learn about the functions of the artefact in terms of their physical makeup. Also by learning about artefacts as systems, students would be able to make connections between the physical and functional nature of the artefacts (de Vries, 2005). Therefore, from a philosophical perspective, the view of technology as artefacts has implications for teaching and learning about technology.

Technology as Knowledge

A definition of the very word technology is often thought to connote knowledge, for example, Lux (1983) describes technology as 'praxiological knowledge,' (knowledge of practice). Adam (1993) explains the origin of the word technology in Greek as *tekhne*, art or skill, and *logia*, science (knowledge) or study. Thus technology implies a knowledge (science) of practice that involves the practising of an art or skill.

Thus some authors consider technology to be mostly associated with applied science. This view embraces the outlook of the 'Science, Technology and Society' (STS) movement, popular in the USA. Bentley and Watts (1994) suggest that in developing technology education three prominent views of technology-as-science become obvious: first, the application of science knowledge; second, technology as an all-embracing discipline, co-equal with science, but drawing its knowledge from science and other areas; third, technology as a combination of the two previous views, embracing an integrated knowledge and complex weave of ideas and activities. Jones (2005) comments that this is reflected in curricula such as science, social studies, and information technology in New Zealand in the 1970s and 1980s.

According to de Vries, (2005) the nature of technological knowledge has been a topic of controversy for many years, as some philosophers claim technology as

applied science, others claim technology has a body of knowledge different in nature to science. Cluster (1995) argues that technological knowledge predates scientific knowledge; some practical knowledge had been used throughout history long before the relevant explanatory science theories were formulated. He adds that the identification of the right type of stone for a stone axe is practical knowledge, and this knowledge was in existence prior to the development of mineralogy or geological sciences that might be used to explain the reasons such materials were useful for tools. Staudenmaier (1985) identifies technological knowledge as independent of science, and from a historical point of view technological tasks were done without scientific knowledge. Williams (1992) supports this view, and adds “technological knowledge is organised, coherent and intelligible, and is different from scientific knowledge” (p. 84). de Vries (2005) confirms that “nowadays most philosophers will agree that part of what engineers know is of a different nature from what scientists know” (p.29). However, there is a relationship between science and technology, since for scientific knowledge to be made appropriate to meet the specific demands of a design problem, it has to be transformed and restructured to meet practical ends (Staudenmaier, 1985; Williams, 1992).

According to de Vries, (2005) technological knowledge is very distinct from other knowledge in the sense that it can best be acquired through “learning-by-doing”. However, Compton and Jones (2004) explain that while technology can claim its own distinct knowledge, it also uses knowledge from other domains, when needed for undertaking the task at hand. This confirms that a wide range of technological knowledge is needed for teaching and learning about technology. The technological knowledge domain for teaching and learning about technology is identified by Compton and Jones (2004) as:

Technological knowledge includes understanding resources and their part in enabling the success of a technological outcome, including the physical properties of resources, and their current and long-term availability and viability. System/process knowledge focuses on understanding the way things work together as part of an overall outcome. Technological knowledge also includes understanding the social and physical environment of any technological development or site. It includes knowledge of appropriate ethics, legal requirements, cultural or domain protocols and the personal/collective needs of the end-users and technologists specific to the

development as well as the site where the outcome/s of the development may be located. (p.6)

In summary, technological knowledge is distinct from other knowledge domains. It has its own unique knowledge and this is increasingly recognised by scholars (de Vries, 2005). While technology has its own knowledge domain, it also draws knowledge from other domains. It draws from a wide range of knowledge when undertaking technological activities including knowledge of the properties of physical resources, knowledge of the social and physical contexts including ethical and legal requirements and people in society (Compton & Jones, 2004). Technology is an essential part of everyday living for all people. Therefore, technology is important as a school subject (Jones, 2001).

Technology as Process

For other educators, technology is perceived as a process, as the actions or techniques used to develop, produce, and use artefacts. It is more than an object and mental knowledge, and includes human activities, actions of making, and the processes of using technology (Mitcham, 1994). de Vries (2005) echoes a similar view of technological processes as activities where technological artefacts and processes are in constant development. He described technological process under three categories: design processes, making processes, and using and assessing processes.

According to Gardner, (1994) this view of technology is accepted by two distinct groups of educators. The first group believe that the process of technology involves invention, design, innovation, dissemination, and improvements. In this view, technology is seen as an elusive phenomenon without content, and if individuals master the design process, they will then understand technology. The second group of educators see the process of technology as a productive system, which involves a complex network of artefacts, processes and people. In this view, technology is seen as a body of knowledge and actions, used by people, to apply resources in designing, producing, and using products, structures and systems to extend the human potential

for controlling and modifying the natural and human-made environment (Mitcham, 1994; de Vries, 2005). Consequently, technology provides a more comfortable lifestyle for individuals and society, for example, feeding the hungry, and creating more shelter for an increasing population (Wright & Lauda, 1993).

Technology as Volition

Mitcham (1994) also identifies technology as volition. However, Custer (1995) argues that instead of defining technology as volition, it is more proper to refer to technology as having volitional qualities, as technology has the power or tendency to either push or pull in its influence and impact on human values, cultures, institutions, societies, and nations, for better or worse (Custer, 1995; Staudenmaier, 1989; de Vries, 2005). Technology as volition is discussed here in terms of the social impacts technology has on individuals and organisations, and vice-versa. de Vries (2005) discusses technology and the nature of humans, and states that technological activities are intrinsic to humans. Ginner (2007) also advocates similar view of technology as intrinsic to human, and commented that “technology is seen not only as a culture of its own rights but also a part of human culture as a whole” (p.3). In a recent technology development in New Zealand, Compton and Jones (2004) define technology as “a purposeful human activity that expands the dimensions of human possibilities, and in fact challenges notions of what it is to be human” (p.1). de Vries (2005) explains that humans behave technologically because they have needs to be fulfilled. Based on Friedrich Rapp’s ideas, de Vries (2005) explains that humans develop technology for three motives: basic human need to survive, power and control, and show of intellectual capacity of humans. These human motivations to develop technology demonstrate the notion of what it is to be human (Compton & Jones, 2004; de Vries, 2005)

Technology as Organisation

Some authors see technology as an organisation; in other words, it is the way people structure themselves to produce products and services. Burns (1997) suggests that the way a given society is organised has a great impact on technological

developments. She further adds that technology is part and parcel of society; therefore technology is a reflection of society and the way in which a society manages its technological developments. Educators holding this view of technology consider people developing and implementing technology as industrial or managerial organisations, which are responsible for the problems of technology in society (Wright, 1996).

In summary, technology is multi-dimensional in nature (Petrina, 2000) and includes artefacts, processes (de Vries, 2005) - including procedures and techniques, a body of knowledge - both conceptual and procedural (McCormick, 1997), and a societal aspect (Mitcham, 1994; Pacey, 1993). All these dimensions of technology have implications for teaching and learning about technology in schools (de Vries, 2005) and can be identified, classified and systematically studied. So technology denotes an interdisciplinary field of study in the same way as the traditional disciplines such as science, social science, mathematics and language. With this concluding note, the next section looks at the development of technology education internationally.

2.2.3 Development of Technology Education

Technology education is a subject which has been recently developed and is now gaining recognition by many educators and curriculum developers internationally. Internationally, technology education is seen to be very important for a variety of reasons, including educational and economic (Jones & Carr, 1993; McComick, 1992). The development of technology education differs across countries (Rasinen, 2003), and is influenced very much by various existing traditions forming interest groups, which determine what is to be taught as technology in schools (McComick, 1992). Jones (2005) confirms that the development of technology education within countries is set within a historical, cultural, and political environment. Many scholars from a range of countries, for example, Williams (2005) from Australia, Jones (2005) from New Zealand, and Dugger (2005) from USA discuss technology education curriculum in terms of its historical development and the political influences underpinning the developments. The history of technology education

development in many countries can be traced from the days of craft through to a broadening to technological literacy.

Technology education development in Zealand has a long history, back to when technical education was introduced in 1890 (Burns, 1992; Jones, 2003). Jones (2003, 2005) states that the traditional narrow focused technical education shifted during the 1970s and 1980s to include workshop technology, graphics and design. About the same time, technology was also emphasised in other “school subjects such as science (technology as applied science), social studies (technological determinism) and information technology (computers)” (Jones, 2005, p.3). The development of technology in these curricula was perceived as narrow and gender based, and only encompassed a limited range of skills, processes, and knowledge. The curriculum reform undertaken in 1990 resulted in an emerging separate technology education curriculum (Jones, 2003 & 2005). The technology curriculum was then given to schools to be trialled for the first time in 1995 (Mawson, 2007) and was fully implemented in 1999 (Jones, 2005). This technology curriculum aimed at students developing technological literacy through developing technological knowledge, technological capability, and awareness of the relationship of technology and society (MoE, 1995). Since the implementation of the new technology curriculum, two professional development programmes were developed to facilitate an effective implementation of technology in schools. The Learning in Technology Education (LITE) model was undertaken in the primary schools (Moreland, Jones, & Northover, 2001) and the Technology Education Assessment in Lower Secondary (TEALS) model was undertaken in the lower secondary schools (Compton & Harwood, 2003). The 1995 technology curriculum was reviewed in 2006-2008. Further changes were made where the three strands became technological knowledge, technological practice, and the nature of technology (Jones, in press).

In Dugger’s (2005) analysis of technology education development in USA, he noted that the Industrial Arts curriculum in USA evolved from Manual Arts in the late 1800s and early 1900s (Jones, in press), in other countries. It was not until 1994-

1996 the International Technology Education Association (ITEA) and its Technology for All Americans project (TfAAp) worked in collaboration, and they recently published the *Standards for Technological Literacy* (Dugger, 2005). The focus of this document is based on developing student technological literacy in five key areas: the nature of technology, technology and society, design, abilities of a technological world, and the designed world (ITEA, 2000). In 2003, ITEA published another document, *Advancing Excellence in Technological Literacy*. The focus of this document is on student assessment, professional development, and programme standards (Dugger, 2005).

Similarly, Australia also has a long history in regards to the development of technology education. According to Williams, (2005) a technical curriculum was introduced in the 1890s to provide trade training and develop housekeeping skills. It was reviewed in 1950s and 1980s as a solution to combat a period of economic downturn in Australian history. He comments that Australian states and territories worked in isolation educationally and politically. However, in 1994 the Australian Education Council (AEC) released a nationally agreed curriculum statement and profile for eight compulsory learning areas and technology was one of them. The development of technology education in Australia has been undertaken by all states and territories since the AEC released the 1994 statement.

Views of Technology Education Curricula

In the early stages of technology education development, diversity was evident. Black (1994) described five perspectives of technology education. Different countries have adopted these perspectives to varying degrees. The five perspectives are technology as craft skills, technology as design and make, technology as science, technology as design and make and the application of scientific principles, and, technology as practical capability. It was not only the technology curriculum content that varied from country to country, but also the curriculum format. Rasinén (2003) explains that some countries developed a prescriptive curriculum with specific details of what and how technology should be taught. Other countries

developed a less prescriptive curriculum, where only broad goals were outlined and schools had freedom to develop their own curriculum based on these. Still other countries were somewhere in between the two curriculum formats.

Petrina (1998) argues that technology education is a multi-dimensional discipline rather than a mono-discipline subject when considering the historical-political terrain in which it belongs. The adoption of a multi-disciplinary approach to technology education is one way of avoiding the restricted views of different perspectives. Williams (1992) adds that, “technology strives to go outside of itself while many traditional disciplines are much more introspective” (p. 84). In other words, technology does not protect its own knowledge within a confined academic orthodoxy, but rather encourages lateral thinking for solving practical problems (Williams, 1992).

These disparate views reflect the nature of technology education as that of a broad base that includes personal development, both vocational and intellectual. A balance must be maintained between theory and practice, between method and product. Thus, the technology in the New Zealand curriculum document defines technology education as:

A planned process designed to develop students’ competence and confidence in understanding and using existing technologies and in creating solutions to technological problems. It contributes to the intellectual and practical development of students, as individuals and as informed members of a technological society. (MoE, 1995, p.7)

Jones and Carr (1993) argue that the inclusion of technology in the National Curriculum is clearly justified because it has numerous implications for economic, pedagogic, motivational, cultural, environmental and personal reasons. The development of technology education has also become politically desirable, which has been instrumental in increasing the speed of development and in its far-reaching nature.

In summary, technology education is multi-dimensional in nature, and is “based within a philosophical, historical and theoretical context” (Jones, 2001, p.4.; Mitcham, 1994). When developing a technology education curriculum, consideration needs to be given to incorporating all aspects of technology into the discipline. The next section looks at how technology education curricula are developing internationally.

Technology literacy as the international trend for developing technology education curricula

As a discipline, technology is now included in many national curricula as more countries recognise the importance of having a technologically literate population. Technology education is considered to provide hope for the future, as Dyrenfurth (1990) states:

If our schools do not help youths understand technology, if they do not develop the capability to use technology, to assess technology, to control technology, then the only viable prediction is one of catastrophe. Catastrophe such as world wide economic chaos, annihilation, either by war or pollution, or a technocratic society that is foreseen to be controlled by masses of technological barbarians and a cadre of technological elite. (p.12)

According to Rasinen (2003), the technology education curriculum rationale of all the six countries (Australia, England, France, The Netherlands, Sweden, and United States) that he investigated, is that technology is an integral part of our society, and it is important for all students to know about it, and so it should be taught at schools. The technological rationale shared by all six countries in Rasinen’s study has advocated the need to prepare students to live in a rapidly changing technological world. This implies that technological literacy for all students has now become the trend in global technology education development. Jones (in press) confirms that in the last 15-20 years, countries such as Australia, USA, Canada, Europe, South Africa, and New Zealand have emphasised technological literacy as the focus of technology curricula development.

The United States developed a technological literacy curriculum for all, which advocates that it is important for all students to be technologically literate. The

focus of the technological literacy approach to technology education has an intention to enable students to develop knowledge and abilities about human innovation in action. It also establishes the requirements for technological literacy for all students from kindergarten through Grade 12. Technological literacy is also believed to enhance the participation of US citizens in the democratic decision-making process. In other words, a technologically literate population will understand what technology is, how it is created, how it shapes and is shaped by society in terms of maintaining and sustaining its economy (ITEA, 2000).

The New Zealand Ministry of Education produced a description of the New Zealand technology curriculum which is also based on the concept of technology literacy. The concept of the New Zealand technology education curriculum is focused on significant societal contexts which explore the effects of technology on society and society on technology, and “positioned within the socio-cultural theoretical stance” (Compton & Harwood, 2003, p.3). Technology is thus perceived as a creative activity, which combines technological and other knowledge, skills, and resources, to help solve practical problems. Technological practice is purposefully aimed at meeting needs and opportunities through the development of products, systems, or environments within a social context (MoE, 2005). Technology education in New Zealand is thus holistic in its approach and is for all students. Technology education in New Zealand also promotes the development of a liberating technological literacy through empowering students to undertake critique and comparative analysis of past and current technological practices (Compton & Harwood, 2003 & 2005; Jones, 2001).

The recent development of the New Zealand technology curriculum (MoE, 2007), three new learning strands were developed, aimed at helping students to achieve critical technological literacy: the nature of technology, technological knowledge and technological practices. These three strands are explained by Jones (2005):

The nature of technology strand focuses on students developing an understanding of the key characteristics of technology as a field of human endeavour. The technological knowledge strand focuses on students developing technological

knowledge that underpins devices, systems/processes, and procedures. The technological practice strand focuses on supporting students undertaking technological practice and examining the practice of others. (p.4)

Most of the teaching and learning programmes in the New Zealand technology curriculum will integrate all three strands: however, particular units may only focus on one or two (MoE, 2007). This can lead to further awareness of the holistic nature of technology. In teaching and learning technology education students should see the all-encompassing nature of technology, and how other subjects relate to technology education (Burns, 1997). Therefore, “students should be encouraged to access knowledge and skills from other learning areas” (MoE, 2007, p.32).

A technologically literate person understands the relationship between technology and society (Daker, 2005), and will participate actively in controlling technological decision-making (Jones, 2001), making rational and justified choices and become a contributing member of society once they leave school (Rasinen, 2003), and becoming an empowered decision-maker within their learning communities as well as in future communities they may participate in (Compton & Harwood, 2003). Therefore, the focus of technology education curricula development in many countries is now on critical technological literacy (Petrina, 2000). This is achieved by providing students with opportunities to undertake their technological tasks in a highly reflective and critical manner (Compton & Harwood, 2003).

While the development of technology education in developed countries tends towards a liberating technological literacy curriculum, most developing countries focus on developing a technology curriculum that is vocational and skill based (Ding, 2009; Kerre, 1994; Natarajan & Chunawala, 2009; Steven, 2009). However, there are indications that some developing countries such as India, (Natarajan & Chunawala, 2009), China, (Ding, 2009), and South Africa (Steven, 2009) are beginning to incorporate technology education as a subject in its own right with a technological literacy approach.

2.2.4 Teachers' Perceptions of Technology and Technology Education

Teachers' perceptions of technology and technology education have been examined and explored by researchers such as Jarvis and Rennie (1996), Jones and Carr (1992), Moreland (2003), Rennie (1987), and Symington (1987). Not surprisingly, these studies reveal that teachers hold a range of views on technology and technology education. Symington (1987) found that most primary teachers view technology as modern and sophisticated hardware, like computers, lasers and kidney transplants, while other teachers associate technology with a much broader definition. Rennie (1987) suggests that science teachers perceive science and technology to be related. Some teachers, for example, talked about technology as the application of scientific knowledge and others considered technology education to be the use of machines, making things to fulfil a need, or investigating how things work (Jarvis & Rennie, 1996). According to Rennie (1987), teachers considered technology to be artefacts, services, processes and techniques, problem-solving, improving of the quality of life, and environment control.

Prior to the implementation of the Technology in the New Zealand Curriculum (TNZC) document, Jones and Carr (1992) showed that many primary school teachers saw technology education in terms of computers and the use of computers and other technology to solve problems, whereas others saw technology education as finding out how things work. In contrast, most secondary school teachers perceived technology education within the subject subcultures in which they were trained (Jones & Carr, 1992). For example, science teachers talked about technology education in terms of applied science, whereas social studies teachers saw technology education from a social perspective. English teachers considered technology education in terms of media, journalism and drama, while accounting and economics teachers mentioned computers and resources, and technical teachers focused mainly on skills, designing and making (Jones & Carr, 1993). Similarly, Rennie (1987) suggests that science teachers perceive science and technology to be related. Some teachers, for example, talked about technology as the application of scientific knowledge and others considered technology education to be the use of

machines, making things to fulfil a need, or investigating how things work (see also, Jarvis & Rennie, 1996). According to Rennie (1987), teachers considered technology to be artefacts, services, processes and techniques, problem-solving, improving of the quality of life, and environment control.

More recent studies on New Zealand teachers' perceptions of technology and technology education state that teachers now have a broader view of technology and technology education (Moreland, 1998). Other studies found that, although New Zealand teachers' perceptions of technology and technology education have changed from previously held views (Jones & Carr, 1992), teachers still revert to subject subculture approaches when the face difficulties in implementing technological activities in the classroom (Jones, 2001; McGee et al, 2002; Northover, 1997) For example, McGee et al. (2002) state that intermediate and secondary teachers tend to integrate technology into Workshop Technology and Home Economics, as the areas they considered to be the easiest to implement. Jones (2003) explains that secondary school teachers use workshop technology and home economic facilities to teach technology in secondary schools. Even though technology programmes have been established in most primary schools, the teachers' views on student learning outcomes tend to relate to other subject areas such as language and science (Jones, 1997, 2003; Jones, Harlow, & Cowie, 2004; McGee et al., 2002). In another study, primary school teachers viewed technology as practical work and problem-solving through the design process approach (Jones & Moreland, 2004; Moreland, 2003). Thus, there can be a strong influence of subject subcultures on primary and secondary school teachers' perceptions of technology education. These perceptions appear consistent and strongly held (Jones, 2001). In considering the factors influencing teachers' views of technology education, Jones (2003) concludes that time is crucial for enhancing a teaching culture for technology education in New Zealand.

Teachers' views on technology and technology education in the Solomon Islands were examined and reported by Liligeto (2001) and Sade (2002). These studies

reveal that both the primary and secondary school teachers in the Solomon Islands have a range of views and their understanding of technology and technology education is very limited. Teachers viewed technology as consisting of a variety of artefacts and skills. This concept has led teachers to think that the western artefacts and skills are superior to the traditional artefacts and skills of Solomon Islands (Sade & Coll, 2003).

Understanding teachers' perceptions of a subject is seen to be important in curriculum development and implementation, as their perceptions of technology affect what and how they teach (Jones & Carr, 1992). Teachers' subcultures are a strong influential factor in teachers' perceptions of technology education (Jones, 2001; Jones & Moreland, 2004; Jones, Harlow & Cowie, 2004). Teachers' roles, understandings about the nature of a subject, the way a subject should be taught and assessed and expectations of student learning in a subject are influenced by their existing subject subcultures (Paechter, 1992). For example Paechter found that teachers' ties to their existing subject beliefs in craft design, home economics and art were transferred to technology education when they attempted to teach technology in the classroom. Jones (1997) also notes that teachers' classroom strategies are often positioned within particular teaching and subject subcultures. These subcultures directly influence the way teachers structure lessons, plan learning outcomes and develop classroom strategies. For example they develop strategies to allow for learning outcomes that more often closely relate to their existing subject subcultures than to technological outcomes. Sometimes they revert to learning outcomes of familiarity, such as discussion and debating skills in isolation from technological outcomes.

Developing technology education concepts, like other disciplines, requires knowledge of both technology and how students learn. Jones (1997) believes that both student concepts of technology and student learning in technology are of equal importance. There is also evidence that student attitudes and concepts are resistant to change. Burns (1992) comments that students' concepts of technology are limited

in terms of both their practice and learning in technology, and Jones and Carr (1993) also confirm that improving of student learning in technology depends on student understanding of the concepts of technology. Student expectations also appear to strongly influence how they carry out technological activities (McCormick et al., 1994).

In summary, several studies found that teachers' perceptions of technology and technology education were narrow but varied. Teachers' perceptions of technology were influenced by various factors which also impacted their classroom practices. Thus the understanding of teachers' perceptions of technology and technology education is crucial for the development of technology curriculum and its implementation. The literature on curriculum development is discussed next.

2.3 Curriculum Development Context

This section discusses aspects related to curriculum contexts. Section 2.3.1 discusses the literature defining curriculum contexts and the literature on curriculum development is discussed in section 2.3.2. Section 2.3.3 discusses teachers and curriculum decision-making, and teachers' attitude towards curriculum change is discussed in section 2.3.4. Curriculum development in the Solomon Islands is discussed in section 2.3.5.

2.3.1 Defining Curriculum Contexts

The term curriculum itself can have a range of meanings, depending on the context and views of the individual. In the past, curriculum was seen simply as a written prescription of what students should learn. However, curriculum is now seen to apply more broadly, and may cover a broad range of activities and experiences intended to bring about educational outcomes (McGee, 1997). Curriculum can also be seen to apply to what is unintended, in the sense of what is taught unintentionally and what is not taught (Eisner, 1994). The term curriculum applies across a range of levels from national curricula that describe, usually in general terms, what should be taught in schools, through to school curricula that use local contexts to provide more

detail, to classroom curricula that represent what actually takes place in the classroom (Bell, 2005; Bell & Gilbert, 1996; McGee, 1997). Consequently, there is a variety of different perspectives of curricula as described by authors such as McGee (1997), Taba (1962), and Tyler (1949) and these may have a significant effect on the direction and nature of curriculum and how it is developed and implemented (Johnson, 1992).

2.3.2 Curriculum Development

According to McGee, (1997) curriculum development is traditionally determined by a few people and usually occurs at a central location. He adds that curricula developed in this way are very prescriptive and structured in a manner that guides teachers by the curriculum statement content. It also allows central agencies to have more political control over what takes place in the classroom and also in schools. Recent debates on who has control over the school curriculum have led to the current understanding that more control lies with the teachers when curriculum is implemented in schools (Bell & Gilbert, 1996; Eisner, 1994; McGee, 1997; van den Akker, 1998). This recent phenomenon tends to suggest a new frame of thinking that shifts away from linear models of curriculum development as suggested by Taba (1962) and Tyler (1949) towards a view of it as a complex interaction between a variety of stakeholders at different levels. The New Zealand science curriculum (Haig, 1995) and technology curriculum (Jones, 2003) are examples of this recent phenomenon. This view advocates the idea that in curriculum development, teachers are the key decision-makers. Therefore, in practice, the link between professional development and curriculum development is crucial for effective curriculum development and implementation, as curriculum development and professional development are reciprocal and intertwined, whether from practice to policy or policy to practice (Bell, B, 2005).

2.3.3 Teachers and Curriculum Decision-Making

There is a growing belief that teachers, as the key curriculum decision-makers, have considerable control over what is actually taught (Bell & Gilbert, 1996; Eisner,

1994; McGee, 1997; van den Akker, 1998). In the development and implementation of a new curriculum, teachers' views are strongly influential. Consequently, implementation of a new curriculum must consider teachers' perceptions of the new development, and take into account how these views and ideas may influence the formulation and implementation of the curriculum (Jones & Carr, 1993). Jarvis and Rennie (1996) agree that there is a need to explore the ideas and understandings of teachers as curriculum developers before a new subject is introduced. Thus, it is seen as important that in order to tailor a new curriculum, teachers' priorities and past influences that might influence curriculum development and implementation must be taken into account (Goodson, 1991). Teachers' past influences are influential in constructing perceptions of a new area, and Jones and Carr (1992) note that teachers' perceptions are, for example, influenced by their own life experiences.

Implementation of any curriculum also depends on personal beliefs, views and ideas, experiences and influences that teachers have about curriculum implementation in general (Crawley & Salyer, 1995; Jarvis & Rennie, 1996). When a new curriculum like technology education is being introduced and implemented, teachers may not be committed to its implementation. According to Jones and Carr (1993), identification of teachers' views can aid implementation, since any weaknesses on the part of the teachers who are responsible for implementing a new curriculum can be identified, and a strategic plan can be put in place to address such issues. Therefore, Jones (in press) sums it up really well by stating that "all curriculum development is set within the social and political fabric of a nation and or state, in fact all curricula are essentially political".

2.3.4 Teachers' Attitude to Curriculum Change

Teachers' response to change is another dimension in the development and implementation of any new curriculum. Teachers have their own subjective views, and the literature suggests that teachers are not always readily receptive to the implementation of new curricula. Natarajan, and Chunawala (2009) state that teachers will avoid change if the present state is a scary one. Often, teachers who

have already been in a climate of pressure may not see change as a solution but view it as a further problem (Jones & Carr, 1992). According to Claxton and Carr (1991), any change enacted without the commitment of teachers may fail to convey the spirit anticipated, and instead, the curriculum may be implemented only in a rigid mechanical way. McRobbie and Tobin (1995) point out that beliefs about curriculum change are viable only in a limited context. In other words, change may be viable in one context, but not in another. Consequently, a new curriculum may necessitate changes or adjustments in the whole belief system of teachers as they work through curriculum development and implementation (Fullan, 1982; Jones, Mather, & Carr, 1995).

2.3.5 Curriculum Development in the Solomon Islands

The Curriculum Development Centre in the Ministry of Education in the Solomon Islands is the department responsible for developing and monitoring issues related to all curricula at all levels. This department has officers who are responsible for administering and coordinating teacher-workshops that involve teachers in curriculum writing. Curriculum development in the Solomon Islands is centralised, and almost all curriculum decisions are made at the centre. A handbook for curriculum developers was developed by the centre as a guide to enhance consistency, readability and uniformity of all curriculum documents (Rodi & Davy, 2002). However, teachers are still seen as the main contributors to curriculum development and writing in the Solomon Islands. Therefore, to involve teachers in curriculum writing, all curriculum development workshops are restricted to school mid-year holidays only, to make it possible for teachers to attend them.

In summary, curriculum development is political and is influenced by various stakeholders related to the development process of the curriculum in one way or another. Development of a new curriculum requires change, which impacts on teachers as well. A PD programme may assist teachers to cope with the changes when implementing a new curriculum. Literature on PD is discussed next.

2.4 Professional Development

This section discusses aspects that relate to PD. Section 2.4.1 discusses PD in relation to curriculum reform, and a range of PD models are discussed in section 2.4.2. The key principles underpinning effective PD are discussed in section 2.4.3 and a discussion on PD in technology education comprises section 2.4.4. Section 2.4.5 presents the theoretical framework for the PD of technology education teachers in the Solomon Islands, and this section finished with a discussion of PD and teacher knowledge in section 2.4.6.

2.4.1 Professional Development and Curriculum Reform

Changes to curriculum policies impact all stakeholders at all levels related to the curriculum at the national level, teacher and school level, classroom and resource level, and student and their learning experience level (Bell, B, 2005; McGee, 1997). For this reason, Bell, B. (2005) argues that it is essential to consider professional development for all stakeholders at all levels affected by the curriculum reform, so as to enhance the intended change required by the curriculum reform. In developing countries, the Non Government Organisations (NGO) are included as stakeholders as they are significant contributors to professional development and curriculum reform in many developing countries such as India (Natarajan & Chunawala, 2009), South Africa (Steven, 2009) and the Solomon Islands.

Bell, B. (2005), Jones and Compton (1998), and Zuga (1997) affirm that curriculum development associated with PD is an essential step for developing practical curriculum policies and an effective implementation of any new curriculum. PD enhances teacher understandings and teaching practices for implementing a new curriculum as intended. As Jones (2001) points out, teachers who are not familiar with any new curriculum often revert to traditional teaching and their subject subcultures.

2.4.2 Professional Development Model

Bell (1993) describes two competing models that are used for teacher development in association with curriculum implementation. One is the dissemination model, which is based on the technicist/functionalist top-down approach, and the other is the interactive/collaborative model, which is based on the critical/constructivist bottom-up approach. The latter model, which was used for developing science teachers in New Zealand, was found to be more effective and brought about meaningful changes in teaching practice in a lasting way. Meaningful change does not normally occur with top-down dissemination (Bell, 1993). Engelbrecht, Ankiewicz and De Swardt (1998) also found that a top-down approach through a cascade PD model used in South Africa was ineffective. The messages passed down were diluted and distorted each time the information was cascaded. The interactive/collaborative model is based on an integration of social, personal, and professional development (Bell, 1993; Bell, B, 2005; Bell & Gilbert, 1996). A technology professional development model, based on a socio-cultural approach, was found to be very effective in enhancing teacher changes in New Zealand (Jones & Moreland, 2004).

2.4.3 Effective Professional Development

Bell, B, (2005) points out that an effective PD programme should empower teachers to try out something new by themselves, even well after the professional development process ends. Another issue identified is the need for professional development to be ongoing. A long-term PD programme based on an ongoing process is crucial for effecting changes in classroom practice (Bell, 1993; Bell, B, 2005; Jones, 2003; Jones & Compton, 1998). This implies a culture of professional development that sees continual professional growth and change as important for effective teaching practice.

The other issue, which may also indicate the effectiveness of a professional development programme, is positive teacher response to the changes anticipated. The development of a new curriculum may necessitate changes or adjustments in

the whole belief system of teachers as they work through curriculum implementation (Fullan, 1982; Jones, Mather, & Carr, 1995). Teacher response to changes required by any new curriculum is a complex process. Often teachers, who have already been in a climate of pressure, may not see change as a solution but view it as a further problem (Jones & Carr, 1992). Bell (1993) and McGee (1997) agree that the teachers themselves must recognise the need for change, and see it as preferable to their current situation, before any change can occur. According to Claxton and Carr (1991), any changes enacted without the commitment of teachers may fail to convey the spirit anticipated, and instead, the curriculum may be implemented only in a rigid mechanical way. Inevitably, it may also affect the changes anticipated in student learning.

As has been mentioned, the teacher change process is complex. However, long-term PD programmes can have an affect on this process. Jones and Moreland (2004) point out that the long-term, on-going, PD in technology education in New Zealand has enabled technology education teachers to have a much broader view of technology and technology education, consistent with the technology curriculum.

A PD programme in itself is a form of teacher support. An effective PD programme enhances teachers' confidence to adjust to new situations. Jones and Moreland (2004) point out that teacher support is a crucial feature for enhancing teachers' confidence in implementing a new curriculum. Teacher support in PD includes teachers talking to each other and school-based support, including administrative support (Bell, 1993, 2005; Bell & Gilbert, 1996). Talking to each other about teaching practice is important, both in providing a feeling of support for the teacher and in helping to develop consistency of concepts. It also helps teachers feel more in control of their own development (Bell, B, 2005). Effective PD empowers teachers to interact and provide support for each other.

PD also provides opportunities for teacher learning. Bell, B, (2005) affirms that good PD with curriculum aims for teachers to learn about various aspects of the new

curriculum. Therefore PD is about teachers learning “how to implement a new curriculum - from policy to practice, and new teaching or assessment strategies” (Bell, B, 2005, p.181). Teachers have to see themselves as learners where PD is a form of learning, which could enable teachers to develop socially, personally and professionally (Bell, B, 2005; Bell & Gilbert, 1996). The key factors highlighted in the literature for successful PD programmes include addressing teachers’ personal, social and professional needs, teacher support, feedback and reflection.

2.4.4 Professional Development in Technology Education

Researchers stress that several issues need to be considered when developing PD programmes in technology education (Compton & Jones, 1998; Jones, 2001, 2003; Jones & Compton, 1998; Jones & Moreland, 2004). Some of these issues are that teachers should develop a robust concept of technology and understand technological practice. Teachers also need to experience technological practice in some form, rather than just have knowledge about it. As Jones (2001, p.9) comments, “technological practice needs to be experienced, reflected on and critically analysed” in order to develop an appropriate concept of technology. Compton and Jones (1998) state the importance of teachers establishing links with technological communities to enhance teachers’ technological concepts and provide teachers with some form of experience in technological practices. Teachers also need to understand the technology curriculum itself and technology appropriate pedagogies to be fully confident when implementing technology education in the classroom (Jones & Moreland, 2004; Moreland, 2003). Jones and Moreland (2004) additionally emphasise the importance of teacher knowledge, particularly pedagogical content knowledge, for teaching technology education effectively. They point out that students’ learning in technology education is enhanced when teachers understand more clearly technology-specific learning procedures and outcomes.

2.4.5 Theoretical View of Learning for Professional Development

The use of a constructivist/cognitive theoretical learning model in PD intervention programmes has been found to be effective in effecting teacher change. PD practices that address the social, personal and professional needs of teachers have impacted positively on teacher learning (Bell, B, 2005; Bell & Gilbert, 1996). A long-term ongoing approach to PD was effective with New Zealand teachers teaching science and technology education in new ways (Bell, 1993, 2005; Jones, 2003; Jones & Compton, 1998; Jones & Moreland, 2004).

Cognitivism, in contrast to behaviourism, looks at more the intellectual or mental aspects of learning. While behaviourism emphasizes the teachers' role in organizing the learning situation and passing information, cognitive approaches deal mainly with questions relating to cognition, or knowing. Cognitive theories are about how we develop our knowledge and how we eventually arrive at notions of ourselves as learners and problem-solvers. The constructivist view is that the conception held by each individual guides understanding. Accordingly, learning is not viewed as transfer of knowledge but as the learner actively constructing, or even creating, his or her knowledge on the basis of the knowledge already held. Piaget's concepts of assimilation and accommodation learning theory are processed through constructivism (Biddulph & Carr, 1999).

Social constructivists view learning as occurring as a result of social interaction, discussion, open-ended questioning, and meaningful contexts. The social constructivist model promotes cooperative situations with much interactive conversation in the classroom between teachers and students, and students themselves (Biddulph & Carr, 1999). The social constructivist theorists view the concept of learning as a social process. Vygotsky and his colleagues viewed development occurring in zones of proximal development where culturally valued skills are taught by experienced members to others in the community (Vygotsky, 1978). Learners learn through a process of being exposed to new knowledge and then attempting to make sense of the new knowledge in terms of existing

knowledge. Understanding involves creating links to existing mental frameworks. The acquisition of new concepts is dependent on the learner's previous learning experiences and an analysis of what the student is now ready to learn with the help of an adult or peer. Hodson and Hodson (1998) affirm that the cognitive and communicative tools, and skills, of a culture are learnt by a child through social interaction with family members, peers and adults. According to Resnick "the social context in which cognitive activities take place are an integral part of that activity" (1991, p.4). She adds that individual psychological development can only be understood if the "social relation in which the individual lives and grows" (p.8) is taken into account. According to Brown, Collins, and Duguid "concepts are situated and progressively developed through activity, and they are not abstract or self-contained entities" (1989, p.33). The situated perspective supports the notion that "knowledge moves from being private to being shared through engagement in social activity and discourses" (Hennessy, 1993: p.3). The theoretical framework of the PD programme undertaken in this study is grounded on the social aspects of these theories.

2.4.6 Professional Development and Teacher Knowledge

This section firstly discusses the significance of enhancing teacher knowledge and teaching practices through PD in general and then focusses especially on enhancing teachers' technological knowledge and practices.

Teacher knowledge and teaching practices

Teacher knowledge is a key factor in successful teaching practice, guidance of student learning and assessment. Therefore, a PD programme focussed on enhancing teacher knowledge will affect teaching practices, student learning and assessment. Desimone, Porter, Garet, Yoon, and Birman (2002) confirm that "professional development is considered an essential mechanism for deepening teachers' content knowledge and developing their teaching practices" (p. 81). Borko (2004) also advocates this view and adds that as educational scholars and policy makers in Colorado, USA, began to realise the significant link between teacher

knowledge and teaching practices, they then demanded that every professional development be focused on helping teachers “enhance their knowledge and develop new instructional practices” (p.3). Developing a knowledge base of the subject is pivotal for teaching (Shulman, 1999). Borko (2004) presents categories of a teacher’s knowledge base in a comprehensive and minimal framework: knowledge of the subject content; knowledge of general pedagogy; knowledge of the curriculum; pedagogical content knowledge; knowledge of the learners; knowledge of the educational contexts; and educational ends, purposes, and values. From this list of the knowledge base, pedagogical content knowledge was highlighted with special interest as it is the “distinctive body of knowledge for teaching” (p.64). Dana and Hoppey (2008) defined the knowledge required for teaching as being of three types: knowledge for practice, knowledge in practice and knowledge of practice. These three types of knowledge somewhat reflect pedagogical content knowledge which blends both content and pedagogy (Shulman, 1999). They explain that knowledge for practice is normally acquired from the experts and is then put into practice. Knowledge in practice is experienced as teachers test out their new knowledge for practice, and knowledge of practice is created by teachers as they uncover new solutions, through logical reasoning and reflection, to address classroom issues which may influence student learning. Therefore, they further add, that addressing all three types of knowledge in a PD programme is crucial for “professional growth that leads to real change” (p. 4). This kind of PD programme addresses teacher knowledge in greater depth for the purposes of effecting real change in teaching. Borko (2004) argues that a PD programme of high quality can result in “teachers deepen[ing] their knowledge and transform[ing] their teaching” (p.5).

Technological knowledge

Teachers of technology need to acquire knowledge of the nature of technology alongside technological practices and technological knowledge (Compton & Jones, 2004) in order to plan and teach technology education effectively. They add that the nature of technology has two important points to consider: firstly “the

understandings of the purpose and concepts of technology;” and secondly “the understandings of the impacts of and influences on technological developments” (p.4). Fox-Turnbull (2006) confirms this, commenting that it is crucial for teachers to have a thorough knowledge of technological practice in order to plan and teach technology education. She further adds that teachers with a thorough knowledge of technological practice were able “to give students quality feedback which will enhance their learning about relevant technological processes and techniques” (p.75). Therefore, in order for technology teachers to teach technology effectively they are required to develop three dimensions of knowledge: “the knowledge about the nature of technology and technological practice, knowledge in technology, such as the technological concepts and procedures, and general technological pedagogical knowledge” (Moreland, Jones, & Northover, 2001. p. 158). Moreland et al. further add that students learning in technology can only be enhanced and sustained if teacher knowledge is focused on “specific and detailed technological learning outcomes in conjunction with appropriate pedagogical approaches” (p.174). In other words, teachers need to have knowledge of specific technological practices, and with the application appropriate instructional practices, students in their learning in technology will be enhanced.

McCormick (1997) identified two main domains of technological knowledge to be considered when teaching technology: conceptual knowledge and procedural knowledge. From a research study on assessment in technology education by Moreland, Jones and Chambers (2001), two more technological knowledge domains were identified, societal and technical, which are used alongside the conceptual and procedural knowledge domain for teaching and assessment in technology. They found that student learning in technology was enhanced as teachers worked across all four knowledge domains which also positively influenced effective teaching and assessment in technology (Fox-Turnbull, 2006; Jones & Moreland, 2004; Moreland et al., 2001). Moreland et al. (2001) point out that using a well developed framework that focused teacher attention on the four knowledge domain is a process for enhancing teachers’ knowledge base. Therefore, understanding the nature of

technology and developing a technological knowledge base in all four domains is crucial for effective teaching and assessment of student learning in technology education (Moreland et al., 2001)

2.5 Summary of the Literature and Research Questions for this Thesis

The literature review on technology and technology education revealed that technology is a new learning area in the school curricula internationally, and is gaining recognition in many developed countries, as a study area in its own rights, and for all students inclusive of gender, background, location, experience, and career aspirations. Technology is not a singular concept, but rather a multi-dimensional concept. This includes artefacts, systems/processes, a body of knowledge, and societal aspects. The literature review also revealed that the development of technology education in many developed countries has a shared view of technology as multi-dimensional in nature, and has focused on technological literacy as the framework for developing their technology education curricula. Technological literacy is also gaining recognition as the framework for developing technology education curricula internationally. The rationale for technological literacy is for individuals to be aware of technology as a major force impacting society, and also for them to actively participate in a democratic society as technologically informed citizens.

The literature review found that the teachers' perceptions of technology and technology education were very influential in curriculum development and the implementation of technology education in their classrooms. Teachers' perceptions were influenced by many factors and these perceptions impact their classroom practices. Therefore, understanding teachers' perceptions was found to be crucial for curriculum development and implementation. The literature also revealed that curriculum development is political and may subtly affect the direction curriculum development and implementation will take. Teacher change was revealed as problematic unless teachers saw a need for it. However, long-term PD programmes

in technology education that focused on developing teacher knowledge and practices, and used best practices for PD, were effective in bringing about teacher change.

The development of the technology curriculum in the Solomon Islands is also based on the broader technological literacy approach to technology education. There was little literature was about technology education PD programmes in the Solomon Islands. Therefore, this study is the first of its kind in the Solomon Islands. The purpose of this study was to develop, implement and evaluate a PD model to be used for preparing technology teachers for the implementation of the new technology curriculum in the Solomon Islands. The study takes into account the teachers' existing perceptions of technology and technology education, classroom practices, and student learning. A PD intervention programme was developed and implemented. The effect of the PD intervention was explored, investigated and evaluated by re-examining the teachers' views, classroom practices, and student learning following the intervention. Data generation for this study was guided by the following research questions:

1. What were the teachers' existing views of technology and technology education, and their current classroom practices?
2. What is an appropriate professional development model for technology education in the Solomon Islands?
3. What effect and influence does a professional development programme have on teachers' concepts of technology and technology education, and their classroom practices?
4. What was the impact of teachers' developing understandings and practices in technology education on student learning?

The methodology used to undertake this study is outlined in Chapter Three. It describes the methodological paradigm and interpretative research design, the need for a multiple perspective approach to data generation and the analysis techniques for this study. Ethical considerations are described.

CHAPTER THREE:

METHODOLOGY

3.1 Introduction

Chapter Two discussed the factors influencing technology and technology education development, curriculum development and professional development related to this study. Teachers' perceptions of curriculum development and implementation, teachers' attitudes towards curriculum change, and curriculum development in the Solomon Islands were discussed. A review of professional development literature concluded that amalgamating professional development with curriculum reform, using effective general professional development models, and approaches specifically effective in technology education, impact on teachers' views and practices in technology.

This chapter describes the methodology used for undertaking such a study. Methodology is considered as the whole research inquiry (Cohen and Manion, 1994) and is used to guide a research inquiry (Guba & Lincoln, 1989). It provides the technical details that guide the research inquiry (Bell, 1999). It sets the basis for the theoretical view upon which the research is undertaken. The first part of the chapter outlines the methodological paradigm for this research in section 3.2, followed by a discussion of an interpretative research design in section 3.3. It describes the multiple perspectives underpinning this interpretive research inquiry, including multiple data generation, data analysis, ethical considerations and establishing quality for qualitative inquiry. Section 3.4 presents the research design for the thesis. It describes the multiple data generation methods used in this inquiry, data generation processes, data analysis methods, validity and reliability, the role of the researcher, ethical issues for this inquiry, and winds up with data sources. The chapter concludes with a summary in section 3.5

3.2 Methodological Paradigm for this Research

The term methodology is often confused with the term methods. According to Cohen and Manion (1994) methodology is best understood as a process, which considers the whole

research inquiry rather than just the inquiry outcome. Guba and Lincoln (1989) also advocate a similar notion arguing that methodology is the overall strategy used to guide a research inquiry, whereas methods are the tools or techniques used in the research inquiry for data collection.

Methodology is best understood as the overall strategy for resolving the complete set of choices or options available to the inquirer. Far from being merely a matter of making selections among methods, methodology involves the researcher utterly - from unconscious worldview to enactment of that worldview via the inquiry process. (Guba & Lincoln, 1989, p. 183)

Educational research, as well as research in other similar areas of inquiry, is typically conducted within a number of competing paradigms. Some of the competing or alternative paradigms are positivism, post-positivism, critical theory, and interpretivism/constructivism (Guba & Lincoln, 1994; Robottom & Hart 1993). As the research reported here was conducted from an interpretive paradigm, this paradigm is discussed in more detail. The post-positivist/constructivist or interpretivist paradigm is characterised by a concern for the individual and a focus on action (Miles & Huberman, 1994). This paradigm is based on a relativist ontology, which “asserts that there exists multiple socially constructed realities ungoverned by any natural laws” (Guba & Lincoln, 1989, p. 84). Hence, interpretivist research focuses on the revelation of the participants’ views of reality, rather than external true reality (Lather, 1992). Bryman (2001) also advocates that the interpretivist paradigm’s ontological position is social constructivist, arguing “that social properties are outcomes of the interactions between individuals, rather than phenomena ‘out there’ and separate from those involved in its construction” (p. 264). Cohen and Manion (1994) explain that an investigation using this model is ascribed to a subjective epistemology, and add that the main focus of the interpretative paradigm is to understand the world of human experience and how individuals are actively or directly involved in this world. Bryman (2001) adds that with an epistemological position of the interpretivist paradigm, “the stress is on understanding of the social world through an examination of the interpretation of that world by its participants” (p. 264). An interpretivist paradigm considers that the object of study and the investigator are interdependent; hence, the methods selected for this inquiry involved interaction between the researchers and the participants (Guba & Lincoln, 1989; Maykut & Morehouse, 1994). With this theory, knowledge is socially constructed and obtained through social interaction where a discourse is negotiated through a dialectal approach between the researcher and the participants (Guba & Lincoln, 1989; Resnick, 1991). This highlights the social constructivism

view of learning, which affirms that knowledge is socially constructed and situated, where learning and the context in which learning takes place cannot be separated (Hennessy, 1993; Resnick, 1991). This approach set the basis upon which the theoretical perspective of this research inquiry was grounded and the methodological approach and methods were selected.

For this research inquiry, a qualitative case study approach, based on the interpretivist paradigm (Guba & Lincoln, 1989), was an appropriate methodology for data gathering and analysis, as rich descriptions with detailed explanations of the processes, and deeper understanding of the key issues influencing teachers' perceptions and their classroom practices were obtained. This methodological paradigm enables the researcher to explore the sequence of development and identify situations affecting the process being investigated (Maykut & Morehouse, 1994; Miles & Huberman, 1994), and to see the development process of the teachers' change of views and classroom practices through the eyes of teachers and students as research participants (Bryman, 2001). The methodological paradigm also enabled the researcher to explore and identify the key issues that influenced the success or failure of the professional development in a flexible manner without a pre-determined, rigid structure (Bryman, 2001).

3.3 Interpretivist Research Design

The research undertaken in this project sought a practical understanding of the teachers' experiences during the professional development and classroom practice, as it explored how the professional development programme influenced the teachers' concepts of technology and technology education, as well as their classroom practices. Creswell (1998) points out that interpretive research engages researchers in building a complex and holistic picture in a natural setting (in this case the secondary technology teachers' classrooms). The context in which this research study was conducted was quite complex. Therefore, the interpretivist paradigm methodology was adopted as the most appropriate for gaining a practical understanding of meanings and actions in complex contexts.

Cohen and Manion (1994) argue that the main focus of the interpretative paradigm is to understand the world of human experience and how individuals are actively or directly involved in this world. The interpretivist approach views the world through the medium of interpretation (Banister, Burman, Parker, Taylor & Tindall, 1994). Therefore, the researcher

was committed to seeing events and the social world through the eyes of the research participants in order to interpret that world from their perspective (Bryman, 2001). The theory so generated must make sense to those to whom it applies and the researcher needs to understand the actions and meanings (Cohen & Manion, 1994). As an interpretivist research design took on a multiple perspective approach (Burns, 2000), it allowed teachers and students to speak for themselves (Maykut & Morehouse, 1994), and took into account their interpretations (Denscombe, 1995). It also fostered a process of dialogue for both researcher and participants to bring meaning and understanding that reflected the data (Creswell, 1998). Hence, the multiple perspective approach methodology selected considered the role of interpretation in creating understanding. The interpretivist paradigm also considers the researcher as an integral component of the inquiry; therefore, the real issue lies with finding ways in which the inquiry can be enhanced with the researcher's presence taken into account. A researcher is a participant observer in the interpretive process, and also part of the data generation process (Bryman; 2001; Guba & Lincoln, 1989; Miles & Huberman, 1994) by undertaking several positions from being an observer to an internal participant (Robottom & Hart, 1993). By undertaking such positions, the intentions, motives, and reasoning of the participants were identified, defined, and understood through an interpretivist paradigm, and this allowed for a deeper understanding on the part of the investigator about these issues as the investigation progressed (Maykut & Morehouse, 1994).

Cohen and Manion (1994) suggest that an interpretivist worldview is useful in understanding and comparing data gathered at different times or places within similar contexts, and Miles and Huberman (1994) point out that the interpretivist approach is that which is concerned with providing a practical understanding of meanings and actions. The research reported in this thesis sought to explore in depth the understanding of some Solomon Islands secondary technology teachers' existing perceptions of technology and technology education, and classroom practices and the impact of professional development on these teachers' perceptions and classroom practices. Therefore an interpretivist multiple perspective approach was employed.

3.3.1 Multiple Data Generation Methods

Case Study

Adelman, Jenkins and Kemmis (1977) state that case study is a type of qualitative research inquiry that has multiple research methods under its umbrella term with a goal to focus

inquiry around instances (cited in Bell, 1999). Merriam (1988) defines case study as a single instance or a bounded system of a social phenomenon such as an individual, event, group, intervention, or community. Cohen, Manion, and Morrison (2000) and Denscombe, (1998) assert that case study is a systematic type of inquiry. It takes a holistic view of investigation and gives insights into particular instances, events or situations. The holistic approach encompasses multiple sources for data collection (observations, interviews, archives, records, policies clinical, legal documents) in order to explore variable relationships and phenomenon within natural settings.

According to Cohen and Manion (1994) the strength of a case study lies in the attention to the subtlety and complexity of the case in its own right. A case study approach to a research inquiry provides a perfect opportunity to go into sufficient detail to uncover complexities of given situations (Denscombe, 1998). A case study is a social process (Burgess, 1982) and takes into account the participants' own accounts, individual perspectives, and explanations of situations (Cohen & Manion, 1994). Giving feedback information to participants accesses their interpretations and enlisting their responses strengthens the case. According to Denscombe (1998) and Cohen et al. (2000), a case study generally focuses on providing an in-depth account of events, relationships, experiences or processes of a contemporary phenomenon in social settings or real life situations.

A case study approach provides an ideal method for this particular study, which was situated in the context of technology education and secondary classrooms in the Solomon Islands as a developing country. It was preferred for its suitability for an in-depth study of a small group of eight secondary school teachers from six schools undertaken by an individual researcher over two years. A qualitative case study approach was used because of the small sample size, as well as the depth of meaning required in understanding the Solomon Islands secondary teachers' perceptions of technology and technology education and their classroom practices. Furthermore, because of the difficulty of understanding English, it being a third language for these Solomon Island teachers, a qualitative case study approach gave participants the opportunity to query questions if they were not clear.

The study also fitted a case approach because the cases were clearly bounded. They were bounded by people: secondary school technology teachers and their students; they were bounded by time: two years for data generation; they were bounded by place: secondary

school classrooms; they were bounded by subject: technology and technology education. Contexts and settings were taken into account and included the localised context of the Solomon Islands as a developing country.

In qualitative case study research, multiple methods of data generation are used. According to Creswell (2003), data collection procedures in qualitative research involve four basic types: “unstructured (or semi-structured) observations, interviews, documents, and visual materials” (p.185). All four basic types of data collection procedures are worth discussing as they all provide the basis for this case study research. However, for the purpose of this study, documents and visual materials are discussed together under documentation.

Interviews

Interviews were the main research method used for data generation. Interviewing can produce information which cannot be accessed through questionnaires (Bell, 1999). An interview is regarded as a social interaction or a conversation between two or more people. Interviews have many purposes with many variations in a wide context. Cohen and Manion (1994) state that:

Interviews may be used as a means of evaluating and assessing a person in some respect; for selecting or promoting an employee; for effecting therapeutic change, as in the psychiatric interview; for testing or developing hypothesis; for gathering data, as in surveys a experimental situations; or for sampling respondents opinions, as in doorstep interviews. (p. 271)

Regardless of all these variations, the common denominator identified by Cohen and Manion (1994) is the transaction that occurs between the interviewer who is seeking information, and the interviewee who is supplying information. Although the purpose of interview in the wider context of life is varied, the particular interview technique discussed here is confined to interviews used for gathering research data in qualitative inquiries. Cannell and Kahn (1968) defined a research interview “as a two person conversation initiated by the interviewer for the specific purpose of obtaining research relevant information and focused on content specified by research objectives of systematic description, predictions or explanation” (p. 271). Cohen and Manion describe four types of interview: structured, semi-structured, unstructured, and non-directive. For the purpose of this thesis, only the semi-structured interview is discussed.

Semi-structured Interview

The focused interview has a theme or focus, and the interviewer guides the discussion towards this focus, while the participants express themselves freely within the topic. As Cohen and Manion (1994) comment, this type of interview “focuses on a respondent’s subjective responses to a known situation in which he/she has been involved and which has been analysed by the interviewer prior to the interview” (p. 273). With this procedure the interviewer has to continuously evaluate the interview while it is in progress.

Like any inquiry method, semi-structured interviews have strengths and weakness. One of the distinctive advantages of the interview suggested by Bell (1999) is its ‘adaptability.’ As she explains:

A skilful interviewer can follow up ideas, probe responses, and investigate motives and feelings, which the questionnaire can never do. Questionnaire responses have to be taken at face value, but a response in an interview can be developed and clarified. (p. 135)

The nature of this method allows more room for interaction between the interviewer and the respondent. The interview is also viewed as a two-way opportunity. While the interviewer has an extensive opportunity to ask more open-ended questions in a semi-structured interview, the respondent has an extensive opportunity to ask the interviewer for clarification of the questions.

Bell, Osborne and Tasker (1985) also support this form of inquiry in the qualitative approach. Semi-structured interviews, for example, allow the interviewee the opportunity “to query the wording and meaning of a question” (p.157). Also, in cases where the respondent misunderstood or misinterpreted a question, the interviewer can further “clarify the questions and clear up any misinterpretation” (p.158).

The interactive nature of the semi-structured interview, whilst providing the advantages described above, makes it a highly subjective method, liable to bias. Selltiz, Jahoda, Deutsch and Cook (1962) note that “interviewers are human beings ... and their manner may have an effect on the respondents” (p. 95). Nevertheless, Cohen and Manion (1994) suggest some means to reduce the likelihood of bias:

Some writers suggested that bias can be reduced by: careful formulation of questions so that meaning is crystal clear; thorough training procedures so that an interviewer is more aware of the possible problems; probability sampling of respondents; and

sometimes by matching interviewer characteristics with those of the sample being interviewed. (p. 281)

Kitwood (1977) agrees that all kinds of bias can largely be eliminated with skilful interview techniques. He further states that accurate data can be obtained if the interviewee is sincere and well motivated. In addition, the use of multiple methods also increases the trustworthiness of data generated, rather than totally depend on what is said in an interview alone (Bryman, 2001). Therefore, other methods of data gathering such as, observation and document analysis were also used to access other important areas, which could not be accessed through semi-structured interviews.

Observations

Observation was used in this research inquiry in association with other research methods as a way of generating data and validating the research data (Bell, J, 2005). Bell, J, (2005) notes that the use of observation is to uncover “whether people do what they said they do or behave in the way they claim to behave” (p. 184). Yin (1994) affirms that the evidence gathered from observation is useful information for providing support for the topic being studied. Cohen, Manion, and Morrison (2007) outline five dimensions to be considered in observation:

(a) structured, systematic and quantitative observation versus unstructured and unsystematic observation; (b) participation observation versus non-participation observation; (c) overt versus covert observation; (d) observation in natural setting versus observation in unnatural, artificial setting; (e) self observation versus observation of others. (p.398)

However, for the purpose of this thesis, this discussion will focus on one kind of observational research technique and that is participant observation. Participant observation is when the researcher has become part of the object of study, rather than merely a passive observer (Yin, 1994). The researcher observes the object under inquiry as he/she participates in their activities and tries to see what they see by being with the people of the social setting being studied. An on-going interaction or long term involvement of the researcher with the participants in the same activities assists in building confidence and identity with those in the social setting being studied (Bryman, 2001, Denscombe, 1998). Participant observation enables the researcher to have a better view and understanding of the social world of the classroom. It also enables the researcher to gain insights into the culture or event which is being studied (Denscombe, 1998). As the researcher has become a part of the group being studied, a more intimate and informal relationship can be formed with those being observed

(Cohen et al., 2000). The presence of a participant observer may have some reactive effect on those being observed and may cause people to behave less naturally. However, the length of time the participant observer is involved with those being observed is crucial for creating less tension between the observer and those being observed as well as creating natural behavior on the part of the observed participants (Bryman, 2001).

The advantage of participant observation is that the observation procedures are normally planned beforehand. This guides the researcher on what to focus on during the observation process and this helps to make it clear how the descriptions were arrived at (Bouma, 1996; Cohen & Manion, 1994). However, with pre-planned observational instruments for collecting data, some aspects of the phenomenon under study, which might be of crucial importance, could be missed (Harker, 1999).

According to Cohen et al. (2007), the risk of bias is quite high in many observation situations, as the use of the observation technique is seen as subjective. However, when observation is used only as support data for other data sources the risk of bias is reduced (Bell, J, 2005). Cohen et al. (2007) affirm that observation alone, without evidence from other support data, may not create validity as understanding the reasons, intentions, causes and purposes of people's behavior is also necessary. In the case of reliability in observation, Cohen et al. (2007) argue that there are times when considering "reliability as consistency in observation is not always necessary" (p.404). An incident may be a one off and could activate great interest to the observer, more than the others, warranting detailed recording and offering important insight. They also add that, although these kinds of incidents are non-routine, they are critical in the sense that they may reveal insights that may not be available in routine observations (Cohen et al., 2007). In spite of the criticism leveled at observation as a biased and subjective data collection technique, Bell, J, (2005) agrees that it "can still yield valuable data" (p.187).

Document review

Documentary information is a useful and relevant source of information for many case study topics (Yin, 1994, 2003). Yin adds that the use of documents is helpful in triangulating with other data sources. For example, documents may verify specific information gathered from interviews; they provide other specific information for collaboration purposes with other data sources; and they provide inferences worthy of further investigation. Creswell (2003) also

affirms that documents enable researchers to cross check for language and words used by participants during interviews. Different forms of documents can be used by a researcher using the case study research approach. Both Creswell (2003) and Yin (2003) state that some of those documents include public documents, such as policies, agendas, meeting minutes, letters, curriculum materials, newspaper prints, and private documents such as, letters, diaries, journals and email discussions. Other documents include audiovisual materials, such as photographs, videotapes, art/drawing objects, computer software, films etc., (Creswell, 2003). Bell, J, (2005) and Creswell, (2003) explain that documents can be divided into two categories: primary sources– “information directly from people or the situation under study” (Creswell, 2003. p.190); and secondary sources – “secondhand accounts of people or situations written by others” (Creswell, 2003. p.190), although, it may be difficult to differentiate between the two (Bell, J, 2005). According to Bell, documentary materials could also provide either facts or biased views on the subject. Therefore, in analysing documentary evidence it is important to see through the eyes of the authors in order to understand the views presented to avoid personal bias interpretation (Bell, J, 2005). The documentary materials used for this research were also used as supporting materials and are discussed later under research design section 3.5.2.

During the data analysis, it is important that the data generated from interviews, observations and documents are summarised and categorised in some form of themes and patterns in line with the research questions or objectives (Bouma, 1996). Additionally, a vital issue to consider in maintaining the validity of the data generated in a qualitative case study research inquiry is to constantly make reference to the data generated from interviews, observation, and documents concurrently (Creswell, 2003; Merriam, 1988). The methods used for generating data were interviews, observations during professional development programmes and classroom practice, and the teachers’ and students’ working documents. The working documents included copies of teachers’ lesson plans, teaching materials, assessment documents, and the students’ written and practical tasks. Each teacher was given an opportunity to monitor the data they were providing, and their confidentiality was protected. The codes were used for schools, and pseudonyms were used for names of teacher participants.

3.3.2 Data Analysis

Face to face semi-structured interviews are time-consuming, and Bell (1999) notes that “such interviews require a great deal of expertise to control and a great deal of time to analyse” (p. 138). However, the power of the technique is seen in Bell’s (1999) comment, that body language, “the tone of voice, facial expression, hesitation, etc., can provide information that a written response would conceal” (p.135). Subsequent questioning can also be used to investigate the depth of the answers in order to probe further the interviewees’ responses.

The interview is a subjective method, therefore bias may creep into the interviews and may affect validity and reliability. Cohen and Manion (1994) argue that “the cause of invalidity is bias” (p.281). Lansing, Ginsberg and Braaten (1961) define invalidity as “a systematic or persistent tendency to make errors in the same direction that is to overstate or understate the true value of an attribute” (p. 281). But Cohen and Manion argue that validity can be achieved if the amount of bias is minimized as much as possible. The sources of bias are identified as “characteristics of the interviewer, the respondent, and the substantive content of the questions. Studies have shown that race, religion, social class and age can, in certain contexts, be a potent source of bias” (p. 281). Kitwood (1977) points out the contrast between validity and reliability in relation to overcoming the bias in an interview. Reliability would increase if the sources of bias were controlled, and the converse would be true for increased validity.

When analysing case studies, Merriam (1998) states that a two stage analysis can be undertaken a within-case analysis and a cross-case analysis. With within-case analysis, each teacher would be analysed separately as an individual case. With cross-case analysis, relationships and patterns would be explored across the cases to find out the commonalities and differences. Such a two-stage method of data analysis, means that the case study themes can be compared and general explanations can be drawn across cases. By integrating data and interpreting meanings of the cases, a better understanding of the people and settings being studied can be obtained (Creswell, 1998; Maykut & Morehouse, 1994). These data analysis approaches underpin this interpretive research.

3.3.3 Ethical Considerations

Ethical considerations are key considerations underlying qualitative research, as meanings are constructed through social interaction between the researcher and research participants.

The continuous interactions between the researcher and participant throughout the research must be open and honest (Banister et al., 1994). Cohen et al. (2000) point out that establishing good relationship is the key to creating mutual respect and confidence between researcher and participants. Within the participants' four key ethical principles to be considered in social research are (a) whether there is harm to participants; (b) whether there is a lack of informed consent; (c) whether there is an invasion of privacy; and (d) whether deception is involved (Diener & Grandall, 1978 cited in Bryman, 2001). These ethical principles guided the undertaking of this research. Therefore, it is the responsibility of the researcher to monitor every situation in an effort to minimise any potential harm for the research participants and also to carefully consider the impact of the research experience (Bryman, 2001). Other responsibilities include getting an informed consent from each research participants, and ensuring the rights of the participants' privacy and confidentiality are respected in the handling of the data throughout the research process (Banister, et al. 1994; Bryman, 2001; Cohen, et al. 2000). Each research participant has the right to access to the data and agreed upon (Bell, 1987). Therefore, in essence, no research participant should be deceived (Bryman, 2001).

3.3.4 Establishing the Quality of a Qualitative Inquiry

Whatever methodology is selected for collecting data for a research study, it should always be examined critically to assess to what extent it is likely to be reliable and valid. The vital aspect that determines the quality of a qualitative research lies with the researcher. Reason and Rowan (1981) note that, "knowledge in a process is tied up with a particular knower" (p. 250). That is to say, there is, of necessity, a focus on personal and interpersonal qualities. In qualitative research, validity has to do with the ability of the researcher to understand and represent people's meanings. The researcher must have confidence in the quality of the data, the interpretation of data, and the ability to generalise the research findings. The means of establishing confidence in a qualitative inquiry are different to those in conventional positivist-based inquiries. According to Guba and Lincoln (1989), when assessing the quality of a qualitative inquiry four criteria are typically used: credibility - equivalent to internal validity; dependability - equivalent to reliability; confirmability - equivalent to objectivity; and transferability - equivalent to external validity. Each of these issues is discussed below.

The credibility of a qualitative inquiry is enhanced by several factors: prolonged engagement, persistent observation, peer debriefing, member checks, and progressive subjectivity.

Prolonged engagement provides opportunities for the researcher to become familiar with the participants and other unknown situations, and to minimise the effects of misinformation. Persistent observation enables the researcher to identify relevant elements related to the issue for the duration of inquiry. Peer debriefing assists investigators to come to terms with their “postures, values and roles in the inquiry” (Guba & Lincoln, 1989, p. 237). The process of negotiation with the participants, checking with group members, provides an opportunity for participants to offer additional information or confirm the data already given. Progressive subjectivity, the on-going monitoring process of the development between the researcher and the participant during the process of inquiry, reminds the inquirer that an investigation is a joint process between the researcher and the participants.

Dependability is concerned with the stability of data over time. This suggests that, although the methodological approaches in qualitative inquiries may have changed or shifted, this would not have any adverse impact on the dependability of the qualitative data, provided the changes or shifts in constructions are identified and described fully (Guba & Lincoln, 1989).

Confirmability is the qualitative equivalent to the positivist notion of objectivity and also contributes to the four criteria that determine the quality of the qualitative inquiry. It attempts to ensure that the results of an inquiry are not subject to undue investigator influence and this is achieved by presenting to the reader the raw data including the transcripts and describing the processes involved from the beginning to the end of the inquiry – that is, providing an adequate audit trail (Maykut & Morehouse, 1994).

Transferability is concerned with the extent to which findings of one study can be generalised or applied to other situations (Merriam, 1988). In quantitative inquiries, sample selection is the essential issue that determines the essence for generalisation. However, in qualitative inquiries, the essence of transferability is shifted from the researcher to the receiver. In this case, it is the reader who decides if the findings are relevant or pertinent to their own situation. The usual way of facilitating transferability judgements is via thick description while the researcher provides a detailed description of all aspects of the research (Merriam, 1988).

Triangulation involves the use of two or more methods of data collection. One of the advantages of this technique is that it allows the researcher to explore the issues of interest

from a variety of sources using an appropriate combination of methods. The issues of concern, and the questions being asked, drive the particular combinations of methods. A decision is made about which method is best for the particular purpose and which data-collecting instruments would best suit the task. The more the methods contrast with each other, the more confidence is gained by the researcher by showing that the research findings were not produced by some peculiarity of source or method.

There are three principal types of triangulation used in interpretivist-based research: data triangulation, investigator triangulation, and methodological triangulation (Cohen & Manion, 1994; Denzin, 1970). Data triangulation involves the use of a variety of different data sources, which could include time and space, an individual person and groups of people, as combined levels of triangulation. Data triangulation is about collecting data from different participants at different stages in the activity of the research and in some cases, from different sites of the setting. It is often useful, for example, to compare data gained from different stages of the fieldwork to research materials, to check if any issues have been neglected or over-emphasised.

Investigator triangulation involves the use of more than one researcher, preferably from different disciplines or perspectives, or adopting different roles. Observers and participants working on their own, each have their own observational styles and they bring multiple viewpoints to the resulting data. The careful use of two or more observers or participants independently, can lead to more valid and reliable data. Reason and Rowan (1981) claim “valid research cannot be conducted alone” (p. 247).

Theoretical triangulation has clear links with investigator triangulation and draws upon the use of alternative or competing theories in preference to utilising one viewpoint only. The investigator should be active in designing his or her research so that competing theories can be tested. Research that tests competing theories will normally call for a wider range of research techniques. This virtually assures more confidence in the data analysis since it is more oriented towards the testing of rival hypotheses.

Methodological triangulation involves the use of different methods to collect data. There are two types of methodological triangulation: within methods triangulation - which uses the same method and employs a variety of strategies; and between methods triangulation - which

uses different methods, for example, interviews and observation, to achieve the same objectives (Cohen & Manion, 1994; Denzin, 1970).

Researchers need to be aware of and open to the possibilities that alternative methods offer, and to continually check the appropriateness and ability of these methods. However, in using triangulation for research inquiries, three possible outcomes are possible: convergence, inconsistency, and contradiction (Denzin, 1970). Data from an inquiry is said to converge when it provides consistent evidence for a particular conclusion. Inconsistency occurs if one set of data neither confirms, nor contradicts the findings of another. Contradiction is when the data disagrees to such an extent that no reasonable explanation can be given. Lack of convergence may cast doubt on the validity of the study. However, looked at from another perspective, it can provide a deeper understanding of the issues under investigation and challenge researchers to re-examine their entrenched viewpoints and positions (Guba & Lincoln, 1994).

It is important to note, however, that whatever method is used in data collection, all methods have their limitations and their own validity threats and distortions. The main purpose of triangulation is to cancel any bias that might be influencing the data, investigator, or a particular method during the research inquiry. The use of triangulation in the research reported in this thesis is discussed below (see under Research Design in this chapter)

3.4 Research Design for the Thesis

This section presents the research design for the thesis. Multiple data generation methods are presented in section 3.4.1, and the data generation process is outlined in section 3.4.2. Section 3.4.3 presents data analysis methods followed by validity and reliability in section 3.4.4. The role of the researcher is presented next in section 3.4.5 and ethical issues for the inquiry in section 3.4.6. This section finishes with data sources in section 3.4.7.

3.4.1 Multiple Data Generation Methods

Interviews in this study

The interview type used was the semi-structured interview using prepared questions. This approach allowed more flexibility in the interviewing process and was better in generating rich discussions of ideas and feelings and also provided an in-depth understanding of the

participant under investigation (Bryman, 2001; Maykut & Morehouse, 1994). Interviews reported here were regarded as conversations for purpose (Lincoln & Guba 1985; Maykut & Morehouse, 1994; Merriam, 1998). Individual interviews formed the major part of the data generated for this research inquiry, as interviews were undertaken with eight teachers and many students. During the interviews, pre-arranged questions were used to guide conversations around the topics. The researcher retained flexibility to probe issues and responses, as they occurred during the interviews. On-the-spot conversations between the researcher, teachers and students were also undertaken in natural settings. These conversations sought teachers and students' views on specific subjects (Bryman, 2001).

The initial teacher interviews took up 40 minutes. They took place at the beginning of the research at the schools during the teachers' class-free time. These interviews occurred subsequently with both teachers and students during each of the researcher's school visits. Researcher and student conversations took up not more than five minutes during class-time when students were working on their class tasks. The semi-structured interviews undertaken with teachers and students in phase one were focused around the sets of questions in Appendix C, and were subsequently used in phase two of the research study. The interviews and teacher conversations during the workshops were audio taped and transcribed, and teachers received their transcripts for verification. The first sets of interviews were used as the basis for understanding teachers' perspectives of technology and technology education upon which the professional development programme was developed.

Participant observation in this study

The observation used in this research inquiry was participant observation. Participant observation was used during the preliminary inquiry in both phase one and phase two of this research. In the first phase of this inquiry, the teachers were observed in their classrooms during a teaching session. In the second phase, teachers were observed during the professional development programmes, and in their classrooms. The researcher undertook participant observation during the second phase of the research inquiry as the Professional Development (PD) provider and researcher. The researcher undertook observations while carrying out the workshops and also while assisting teachers and students in the classrooms. The observations which occurred during the professional development programme were semi-structured in nature, and any interesting issues that occurred during discussions were noted. These observations were supported with field notes. Field notes also the supported

data generated by interviews. Classroom observations were also undertaken in both phases of this research study. During classroom observations the researcher was introduced to the students at first contact by their teachers, so the role as a researcher was never deceptive (Bryman, 2001). The observations were undertaken professionally and consideration focused on building mutual trust between teachers, students, and the researcher. The researcher took on both the role of a researcher and a participant, while observing and interacting with the teachers and students in their classrooms.

In every observation brief notes were taken and were written as full notes soon after each observation, often at the end of the day. Three columns were used for note taking during observations. The first two columns were descriptive notes of both teachers and students' work, and the third column was the researcher's reflective notes on both the teachers and students' work (see Appendix P for an example). The descriptive notes described the activities and conversations undertaken by teachers and students in the classrooms. The researchers' reflective notes were sometimes made at the same time as observations in regards to the activities and conversations undertaken by teachers and students. The recording of notes during observations increased the authenticity of what was being observed. More reflective notes and fuller field notes were written as soon as possible after each observation to avoid information being forgotten, and to help develop a clear picture of what was being observed.

Documentary data in this study

All documentary data were from primary sources. The documentary data collected were MoE curriculum documents, school documents (office records), teachers' lessons, and students' work. The MoE documents were the Industrial Arts textbooks. Teachers' written materials included unit plans and summative assessment formats. Student work included their design folios and photographs, including photographs of students' working in their classroom setting. Photographs of completed artefacts were taken during observations, and also used as a data source. The photographs were used as visual reminders of the kinds of activities and tasks undertaken by teachers and students in their classrooms. Documentary data such as teachers' notes on the board that could not be photocopied were either photographed or written as field notes and also used as a data source. All documentary data collected were authentic in origin, genuine, representative and comprehensive.

3.4.2 Data Generation Processes

Case studies of participating teachers were developed throughout the research study. Data for the case studies came from the recorded interviews and the teachers' teaching materials, as well as from the researcher's field notes taken during the professional development and classroom observations. Each case study described and analysed the involvement of each participant in both phases of the research study. Student data also came from interviews and student work. Every teacher involved in generating data was made aware of what was involved prior to their involvement. Students also knew they could decline to participate.

The data generation was conducted in two phases with a six month interval between. The first phase was completed within a two month period in 2005, and the second within a four month period in 2006. The data generation process for this research inquiry was undertaken in a systematic, organised manner.

The focus of the preliminary inquiry in the first phase was on exploring teachers' pre-existing views of technology and technology education, and their current classroom practice. These teachers were interviewed and all interviews were tape-recorded. Teachers were also observed in their classrooms and field notes were taken. The teachers' teaching material documents were also collected and analysed as data. The first phase of this research study was exploratory in nature, and was analysed during the six month interval after phase one of the research inquiry. The results were used for determining the preparations required for the second phase of the research inquiry. Students in each teacher's class were observed while observing the teachers teaching lessons to see the impact of the teachers teaching approaches on students' activities and learning.

The second phase of the research study focused on the teachers' involvement in the professional development programme and their subsequent classroom practice as they trialed their technology lesson plans. During this phase, data was generated from interviews, researcher's field notes from the professional development and classroom observations, and the teachers' teaching document materials, Student work was collected and their notes from their exercise books, drawings, and compiled design folios. Participants were assigned a pseudonym to protect their anonymity. Data generated in the second phase were analysed and followed with the writing up of the research document. Data were securely stored and will be destroyed three years after the completion of the thesis.

3.4.3 Data Analysis Methods

Case Studies

Three approaches were used to analyse the eight teacher and their students' case studies. First, the case study of each teacher was analysed individually to understand their concepts of technology and technology education, and the impact on the teacher's classroom practice. Second, each analysed case study was compared with the other case studies to identify and categorise common features. Third, the case studies were thematically analysed by comparing case study themes with themes derived from the literature to identify common and contrasting issues. Chapters Four and Five present the cross-case thematic analysis of the findings on teachers' existing views of technology and technology education and teachers' classroom practices. The findings presented in Chapter Four and Five were used as a base to develop the PD intervention programme.

Data generated during phase two of the research inquiry in 2006 was analysed using two strategies. First, Chapter Six presents a descriptive account of the professional development programme and its effects. It describes the stages of the teacher professional development programme, the decisions made and effects of the programme. The chapter is organised in chronological order and so the stage-by-stage report shows how teachers responded to the PD model. Data collection, analysis and interpretation for Chapter Six are amalgamated in this descriptive account. Second, a cross-case analysis strategy was used for Chapter Seven and Eight. Chapter Seven presents the cross-case analysis of the changes made in teachers' perceptions of technology and technology education and the impact on their classroom practices. The impact of teacher change on student' learning is presented in Chapter Eight. Analysing both chapters separately provides a rich picture of the changes to teachers' perceptions and classroom practices and their impacts on student learning as both were analysed from two different perspectives.

Interviews, observation notes and document materials

The data generated by interviews were recorded and transcribed for analysis. The interview data were analysed to identify and explore the changes which occurred in teachers' concept of technology, and technology education. The use of interviews has been shown to be very effective for this type of research, more so than questionnaires. Jones and Carr (1992) comment that interviewing is good for exploring teachers' perceptions in depth because they

allow the researcher to explore issues in complex situations and to follow up unanticipated issues that occur during the interview.

The teachers' transcripts were examined carefully to identify key themes, which were then categorised. The transcripts were then analysed according to the categories. The data generated from the professional development and classroom observation field notes, and the teachers' and students' written documents from the classroom practices were also assessed and analysed as a form of supporting data. Links were established: firstly, between the data generated in phases one and two with similarities and contrasts identified; and secondly, between the professional development and the classroom practice in phase two, with the effectiveness of the professional development also being identified.

Student data were generated from semi-structured interviews and conversations, and also from photocopied materials and photographs of their class tasks. The interviews and conversation were undertaken in the classrooms during observations, and were also recorded and transcribed. (See students' interview questions in Appendix C). The interviews questions with similar format and approach were used in both inquiry phases (2005 and 2006). Student data were analysed to identify and compare the impacts of classroom practices in 2005 and 2006, through within-case and cross-case analysis strategies.

3.4.4 Validity and Reliability

The researcher was very familiar with the context of technology education and the education system in the Solomon Islands. That the researcher spoke the same language as the teacher participants meant that it was easy to understand participants' views when expressed in the Solomon Islands vernacular. This also made translation into English likely to be closely representative of the participants' views. Further details about the researcher are given in the next section. After the interviews were transcribed, the interview transcripts were checked by the participants for verification as being accurate accounts of their views. Member checking gave the participants an opportunity to add to the data by writing clarifying notes on the transcript margins and confirming the data. The teachers' views were also used as a basis for developing the content for the PD programme and this enabled teachers to see how their data were being used in the study. The use of a case study approach with multiple methods of data generation (see Section 3.5.2) and the subdivision of this research inquiry into two phases enabled the findings of this inquiry to be cross-examined between methods enhancing its

confirmability. The two phases also allowed time to confirm data for validity and reliability (Cohen & Manion, 1994; Merriam, 1988). As this research took a multiple perspective view, and adopted several methods for data generation, the conclusions drawn are likely to be accurate and reliable (Miles & Huberman, 1994). The multiple perspective view took methodological and time triangulation into account for enhancing the quality of the inquiry.

3.4.5 Role of the Researcher

The researcher was a Solomon Islander enrolled as a post graduate student studying towards a PhD degree at the University of Waikato. He was a secondary school teacher and was involved in developing the Technology Curriculum in the Solomon Islands. That the researcher shared the same ethnic background as the research participants, and was well known to the research participants, helped put the participants at ease during the data generation process. Participants saw the researcher as a resource figure and indicated that the results of the study would be helpful to technology education teachers at large, as well as to the Ministry of Education in the Solomon Islands. The researcher took on two roles concurrently during this research project. Firstly, as a local Solomon Islander, the research study was conducted through using the cultural norms and accepted practices within the local Solomon Islands community. Secondly, the researcher was the provider of the professional development programme, as well as a participant observer. Every effort was made to minimise the effect on the data generated. Throughout the research inquiry, a professional relationship was maintained. Very importantly, the researcher also ensured that, from the outset of the research endeavour, the potential harms and benefits associated with the study were explicitly explained so that the participants could decide whether or not to participate (Bouma, 1996; Cohen et al., 2000). Therefore, the study could proceed in line with established codes of practice and also foster quality research.

3.4.6 Ethical Issues for the Inquiry

Qualitative studies such as case studies involve human beings as the research participants (Bouma, 1996; Merriam, 1988). Therefore, for access to information, access to research sites and the participants is important (Bouma, 1996; Cohen & Manion, 1994). This research was undertaken within the guidelines and procedures as outlined by the University of Waikato Centre for Science and Technology Education Research Ethics Committee, in Students Guidelines (2005). Initial permission to undertake this research was obtained from the Minister of Education and Human Resource Development in the Solomon Islands as well as

from the Government Research Committee responsible for overseeing research associated with institutions outside of the country. Schools and teachers that have been involved in the study were informed by letter from the researcher about the research (see Appendix F). Every participant who was involved in this research study was made aware of what was expected of him or her, and every participant indicated their willingness to participate in the study prior to their participation. Later, each participant was given access to the interview data, and the rights of the participants' privacy and confidentiality were respected in the handling of the data. Each participant was assigned a pseudonym to protect their anonymity (Bouma, 1996).

3.4.7 Research Participants

Teachers

There are approximately 50 teachers who teach Industrial Arts/Design and Technology in the Solomon Islands. A sample of eight secondary school teachers was selected from six secondary schools for this research study. Some of the teachers involved in this research study had been involved in the development of the recent Solomon Islands technology curriculum, and also had some experience in teaching the Design and Technology curriculum at senior secondary schools. All data were collected from teachers in Honiara because of accessibility. Their range of teaching backgrounds ranged from a beginning teacher to the experienced head of department teachers (see Table 3.1: Teacher backgrounds). These teachers were involved in both phases of the study, first, in the preliminary inquiry in 2005, and second, in the PD phase in 2006.

Table 3.1 shows the backgrounds of the teachers involved in this study. The schools they taught at, the class level the researcher observed in each year, their years of teaching and their current role are shown.

Table 3.1:
Teacher backgrounds

| School | Teachers | Forms Taught and observed in | | Years of Teaching | No. of Schools Taught at | Current Role |
|--------|----------|------------------------------|------|-------------------|--------------------------|----------------|
| | | 2005 | 2006 | | | |
| A | Gilson | 4 | 5 | 5 | 1 | Head of Dept |
| B | Ronald | 4 | 5 | 6 | 1 | Head of Dept |
| | Zebedee | 2 | 4 | 1 | 1 | Assist teacher |
| C | Anthony | 4 | 4 | 24 | 3 | Head of Dept |
| | Richard | 2 | 2 | 3 | 1 | Assist teacher |
| D | Jason | 1 | | 17 | 7 | Principal |
| E | Raymond | 4 | 5 | 20 | 2 | Head of Dept |
| F | Timmy | 2 | 2 | 3 | 1 | Assist teacher |

As shown in Table 3.1, Gilson was the only teacher from school A where he had taught for five years. It was his only school since he began teaching. He was the head of the technology department. He selected a Form Four class for observation in 2005, and a Form Five class in 2006, as he decided to continue with the same students for the research. Ronald and Zebedee were selected from school B which was their first teaching appointment. Ronald had six years of teaching experience in school B and was also the head of the technology department. Zebedee was a beginning and assistant teacher. Ronald selected a Form Four class to be observed in 2005, and stayed with the same students as they moved up to Form Five in 2006. Zebedee selected a Form Two class for observation in 2005. In his second year of teaching, he selected a Form Four class for observation. Anthony and Richard were selected from school C. These two teachers had different teaching experiences. Anthony was the most senior teacher participant in this study, with twenty-four years of teaching experience and also heading his technology department. This was his third school since he began teaching. Richard was an assistant teacher and had been teaching for three years in this school, as his first teaching appointment. Anthony was observed teaching Form Four classes in both years and Richard Form Two classes both years. Jason was selected from school D. He had taught for seventeen years in seven different schools. He was the school principal in his latest school. He selected a Form One class for observation in 2005. For medical reasons, Jason was not included in the classroom observation phase of this study in 2006. However, he still attended the workshops. Raymond was selected from school E. He had taught for twenty years and was head of the technology department in school E. This was his second school since he began teaching. He selected a Form Four class for observation in 2005 and decided to continue with the same students as they moved to Form Five in 2006. School F was the sixth

school. The teacher selected was Timmy, who had taught for three years as an assistant teacher in this school. He selected Form Two classes for observation in 2005 and 2006. It was important that the teachers selected their classes to be observed as this helped them to feel more confident about a researcher coming into their classrooms and to give them a measure of input into the research process.

Students

A large number of students were involved in the technology class is throughout the two years, 258 (144 girls and 108 boys) in 2005, and 97 (no girls and 97 boys) in 2006. For overall class details in 2005 see section 5.2.1 (Table. 5.1) and in 2006 see section 8.2.1 (Table 8.1). The number of students dropped in 2006 for two main reasons. Firstly, eight classes observed in 2005 were reduced to only six classes, and secondly, more teachers decided to use their senior classes for observation in 2006, which only have small numbers due to technology being offered as optional in upper forms. Although, a large number of students were involved, my focus was only on a small number of students. A small number of students in each class were closely observed and their progress was noted. Conversations were undertaken in each class each day and their work was in-depth. In crowded classrooms between four to six students' technology learning were researched. The number of students was higher in classrooms with more room to move around. Student were selected randomly but were represented of both gender (at least in 2005) during classroom observations. In crowded classrooms student data was only generated from those close to where I was sitting. More were observed in classes worked in groups, and almost all students were observed in smaller classes. During participant observations I sat in vacant seats or moved around the classroom talking to students as they worked on their tasks.

3.5 Chapter Summary

An interpretive paradigm was the research methodology for this research inquiry. Qualitative case studies with multiple perspectives were the approaches used for undertaking this research. Data were gathered through multiple data generation methods: interviews, participant observations, and documentary review. The quality of the data generation and analysis has been taken into account based on Guba and Lincoln's (1989) criteria, such as credibility, dependability, confirmability, and transferability. The use of multiple data generation methods increases credibility and the trustworthiness of the generated data, as

data generated by other methods provide collaborating evidence. Participants' verification of the generated data throughout the study also provides credibility. Confirmability was taken into account through cross-case analysis of the two separate inquiry phases. Ethics consideration was paramount to undertaking this social research. Interaction between the researcher and participants was open and honest and was undertaken in a professional manner. Consents of participants including all responsible authorities were obtained. All efforts to avoid potential harm and to maintain privacy, as ethical requirements were considered. Data analysis was undertaken in three stages and the finding forms the basis of the following five data chapters. A thematic and within-case form of analysis is used for analysing the teachers' existing perceptions and classroom practices which provides the basis for Chapters Four and Five. A descriptive form of analysis is used for the teacher professional development programme in Chapter Six. The descriptive account is presented in a chronological structure to monitor development and progress. A cross-case analysis of changes to teachers' perceptions and classroom practices and their impacts on student learning forms the basis for Chapters Seven and Eight. Chapter Seven presents an analysis of findings from teachers and their classrooms, and Chapter Eight presents an analysis of findings from student work and progress they made. Presenting both views separately provided a rich picture of technology education from two different perspectives.

CHAPTER FOUR:

TEACHERS' PERCEPTIONS OF TECHNOLOGY AND TECHNOLOGY EDUCATION: 2005 FINDINGS

4.1 Introduction

Chapter Three described the methodology and the techniques used in data generation for this research. A qualitative case study approach within the interpretative paradigm as the methodological approach was highlighted. The chapter also described the interpretative research design approach upon which the design of this study was based. This included the multiple data generation methods, within-case and cross-case analysis methods, ethical considerations, and establishment of the quality of qualitative research. The multiple data generation methods discussed were interviews, observation, and documents. The data analysis methods and where they are being used in the thesis were also highlighted. The data sources, which focused on teachers and the classes they taught, were also described.

This chapter presents the 2005 research findings related to the eight teachers' existing perceptions of technology and technology education in an attempt to answer the first part of research question one. The second part of question one is answered in Chapter Five.

1. What are the teachers' existing views of technology and technology education, and their current classroom practices?

Understanding the teachers' perceptions of technology and technology education was crucial, as these may influence the way teachers plan and teach the technology curriculum in their classrooms. This chapter is based on the analysis of interview data generated from individual teachers' responses to a semi-structured interview schedule (see Appendix C) undertaken between 19 September and 13 October in 2005. Section 4.2 describes the range of views held by secondary school teachers about technology. Similarly, the views teachers held about indigenous or traditional technology are

highlighted in section 4.3. Section 4.4 describes the range of views teachers held about technology education. The range of views teachers held about the significance of technical and technology education is discussed in section 4.5. This is followed by the teachers’ classroom technology activities in section 4.6. Section 4.7 discusses the teaching pedagogies which teachers expressed as technological pedagogies. Section 4.8 describes the teachers’ views related to assessment and a chapter summary is presented in section 4.9.

4.2 Teachers’ Perceptions of Technology

This section examines the range of views held on technology by eight secondary technology school teachers in the Solomon Islands and these are categorised into three themes. The first theme is technology as artefact; the second is technology as making something; and the third is technology as applied knowledge (see Table 4.1: Teachers’ perceptions of technology).

Table 4.1
Teachers’ perceptions of technology

| Teachers perceptions of technology | Number of teachers / 8 |
|---|-------------------------------|
| • Technology as artefact | 3 |
| • Technology as making something | 3 |
| • Technology as applied knowledge | 2 |

As shown in Table 4.1, teachers’ perceptions of technology covered a range of views. Out of the eight teacher participants, three held the view of technology as artefact, three teachers held the view of technology as making something, and two perceived technology as applied knowledge. These views are discussed next.

4.2.1 Technology as Artefact

The interview data revealed that three out of the eight teachers considered technology to be foreign artefacts. The teachers who held this perception of technology talked about technology as either a foreign thing or something new to the Solomon Islands and with

no origin in the Solomon Islands. One of the teachers, Gilson, specifically referred to cars as technology as they are a new means of transportation in the Solomon Islands.

When I think of the word technology I think of the new things that we have in our time today... like the cars on the road that are used for transportation is technology, because we didn't have them before and they are new to us.

Another foreign artefact also used in the Solomon Islands is the computer. Another teacher, Richard, who perceived technology as an artefact, talked about technology as computers:

When I think of the word technology, I think of it in terms of computers, which everyone in the world today is using which also includes the Solomon Islands.

While foreign artefacts were singled out by two teachers as technology, another teacher perceived technology to be inclusive of both foreign and indigenous artefacts. Jason stated:

Before when I think of technology I think of something foreign which comes from outside of the country, like, for example, in communication, the use of telephone, internet etc., as well as spacecrafts that scientists used to go up into space, and not the things done within our country. Now I tend to see technology as not just something foreign but it can also be the things that are done within our own country basically to improve our quality of life.

Of the three teachers who shared the view of technology as artefact, two teachers viewed technology to be foreign artefacts or artefacts new to the country, and one teacher viewed technology as those artefacts inclusive of both foreign and indigenous artefacts.

4.2.2 Technology as Making Something

Another three teachers held the view that technology was about making something. Ronald talked about technology in terms of the things being made both in schools and in society as technology:

When I think of technology, I think of the things we made. For example, the chairs we made, and many other products like those that are made outside of schools.

Another teacher, Anthony, had the same view that technology was about making something. He believed that technology was about making new things. He also referred to the playhouses built by students in the classroom as examples of technology:

The word technology is the new things that we use in our lives today... technology is not science because science doesn't make things, they only find out how things work, but technology is actually about making new things. For example, in the kindergartens, a child is doing technology when they are building playhouses, building bridges and so forth.

A third teacher in this category of technology as making things, Timmy, also talked about the building activities students undertake in school as examples of technology:

Technology is about the kind of things that we do at schools, like building houses, and doing technical drawings etc.

The three teachers who perceived technology as making something made specific references to the technology-type classroom tasks they taught their students in their own schools. The construction of houses, and house-related products that students undertook at schools were used as examples by the three teachers.

4.2.3 Technology as Applied Knowledge

The other two teachers perceived technology as the application of knowledge. They talked about technology in terms of applying knowledge in a particular situation. For example, Raymond talked about technology as putting knowledge into practice when undertaking a practical task. He said:

Technology is applying knowledge in practical activities. For example, in building a house, you need to acquire knowledge on how to build a house, and when you apply that knowledge in building that house, then that is technology.

Another teacher, Zebedee, shared the same view of technology as the application of knowledge and pointed out that most industrial developments are based on scientific knowledge. He gave building construction as an example of where scientific knowledge is put into practice:

I view technology as something to do with science and in this case I can say something to do with the industrial development. All that is done in the industries is related to science, or are based on scientific knowledge. One example is in a building construction, the laws of physics, such as force is applied, and is considered in this activity, starting from the foundation of a building up to the roof.

Both teachers who held the view of technology as the application of knowledge emphasised the significance of practical or scientific knowledge in practice, and made specific reference to the building industry as an example of practical or scientific knowledge in practice.

In summary, the range of views teachers held about technology were categorised into three themes. The three teachers who considered technology to be artefacts referred to foreign artefacts as technology. The three teachers who considered technology to be something to do with ‘making’ referred to classroom technology tasks, and the two teachers who considered technology to be an application of knowledge used the application of practical and scientific knowledge, particularly in building construction, as an example.

4.3 Teachers’ Perceptions of Indigenous Technology

This section examines the range of views held by the participant teachers on indigenous technology. These are categorised into three themes: (a) indigenous technology as traditional ways of doing things; (b) indigenous technology as locally made artefacts; and (c) indigenous technology as the use of local materials. The teachers’ perceptions in relation to indigenous technology are presented in Table 4.2.

Table 4.2
Teachers’ perceptions of indigenous technology

| Teachers’ perceptions of indigenous technology | No. of Teachers / 8 |
|---|----------------------------|
| • Indigenous technology as traditional ways of doing things | 2 |
| • Indigenous technology as locally made artefacts | 3 |
| • Indigenous technology as the use of traditional materials | 3 |

Table 4.2 shows that out of the eight teachers interviewed, two held the view that indigenous technology is the traditional way of doing things, three viewed indigenous technology as locally made artefacts, while the view of indigenous technology as the use of locally made materials was shared by three teachers. The details of each view are discussed below.

4.3.1 Indigenous Technology as Traditional Ways of Doing Things

The two teachers who held the view of indigenous technology as a traditional way of doing things talked about indigenous technology in terms of how things are done traditionally. Both teachers who shared this view pointed out the use of traditional methods when undertaking traditional tasks. For example, Anthony talked about traditional methods used in gardening:

Indigenous technology is our own method of doing something in our own society like making mounds when gardening, and making digging tools for harvesting potatoes.

Zebedee echoed the same view and pointed out that the traditional approach used in constructing houses was indigenous technology. He noted that the traditional methods of doing things were the older generation's way of doing things. The use of traditional materials was passed down by the older generation to the younger generation. As he stated:

I see indigenous technology as the things our older people have done before, for example, how they had built their houses, and how they had used the local materials to construct their houses. The traditional things which were used before by the older generation are now passed on to us as the new generation of today. For example, the use of traditional building materials that some of us are still using today.

Two main views on indigenous technology as a traditional way of doing things were expressed by the teachers. First, indigenous technology was perceived as the traditional approaches to doing things, such as the traditional ways of gardening and constructing houses and second, indigenous technology was perceived as the older generations' traditional way of life which is still passed down and being practiced by the younger generations of today.

4.3.2 Indigenous Technology as Locally Made Artefacts

Three out of the eight secondary school teachers considered indigenous technology to be the artefacts which are locally made within a country by the local people. Jason perceived indigenous technology to be locally made artefacts and not foreign or imported artefacts:

When we are making our own things from within the country as I have mentioned earlier rather than getting things from overseas. That is what I call indigenous technology.

Gilson shared this view of indigenous technology being locally made artefacts and reiterated that indigenous technology is any artefact which is original or unique to a country. He explained:

Indigenous is something that is original, something that is made in a particular place or country. For example, before we used bamboo for fishing and used bones and stones as fishing hooks. The use of rattan is also another example of our indigenous technology which is still used even today but has been modernised.

Timmy shared the view that indigenous technology is locally made artefacts and he also perceived indigenous technology to be any local artefacts made by the older generation and used as home utensils. As he commented:

Indigenous technology is the things that our older people normally did in the past like making bowls which they had used before for preparing food, and eating utensils and also other traditional things.

From the views teachers held on indigenous technology as locally made artefacts, two views were highlighted; firstly, original artefacts made within a country, and secondly, those made and used by the older generation in the past.

4.3.3 Indigenous Technology as the Use of Traditional Materials

Three teachers held the view that indigenous technology was the use of traditional materials and how they were being used in society. Richard perceived indigenous technology in terms of the traditional materials normally used for building traditional houses:

I think of indigenous technology in terms of the materials that we used for making traditional houses.

In modern communities, building materials have been changed from traditional to modern materials. This transition was highlighted as an indication of the change from indigenous technology to modern technology. Ronald explained that:

Indigenous technology is to do with the buildings that were made of traditional materials that we had before, but now we have buildings made of modern materials. This improvement in our communities is a change from indigenous technology.

Another teacher who also shared this view talked about using traditional materials with new ideas and applied concepts. Raymond viewed the use of traditional materials to make a new product, or introduction of a new application for the traditional materials in society as indigenous technology:

The indigenous technology is when we apply new ideas when working with traditional materials and create new products using the traditional materials. This would require new practical skills to work with our traditional materials.

Two of the teachers viewed indigenous technology as traditional materials and indicated the materials used for traditional houses. The third teacher indicated being creative with traditional materials was part of indigenous technology.

In summary, two teachers perceived indigenous technology to be a way of doing things traditionally and referred to the traditional methods of gardening and building construction and the older generation's way of life. Three teachers perceived indigenous technology to be locally made artefacts and made reference to artefacts originally made within a country and in particular, the artefacts that were made by the older generation. The other three teachers perceived indigenous technology to be traditional materials and made reference to being creative in using the traditional materials.

4.4 Teachers' Perceptions of Technology Education

This section describes the range of views the secondary school teachers held on technology education and are categorised into two themes as outlined in Table 4.3: Teachers' perceptions of technology education. The themes are (a) technology education as hands-on activity education; and (b) technology education as creative activity education.

Table 4.3
Teachers' perceptions of technology education

| Teachers' perceptions of technology education | No. of teachers / 8 |
|---|----------------------------|
| • Technology education as hands-on activity education | 6 |
| • Technology education as creative activity education | 2 |

Table 4.3 shows the two themes which describe the range of views teachers held on technology education and the total number of teachers who held similar views under each theme. Of the eight teachers interviewed, six teachers held the view of technology education as hands-on activity education, and the other two held the view of technology education as creative activity education. The details of each view are discussed in turn.

4.4.1 Technology Education as Hands-on Activity Education

Of the eight secondary school teachers involved in this research study, six held the view that technology education is hands-on activity education. They talked about technology education in terms of students learning to do things with their hands as practical and manual education, and also learning about trade skills. Raymond pointed out:

Technology education is a formal way of teaching students to make things with their own hands.

Ronald reiterated the view of technology education as hands-on activity as well. However, he also emphasised that the acquisition of knowledge is a significant aspect of technology education.

Technology education is about doing things with their hands and acquiring of knowledge as well.

Technology education as hands-on activity was perceived by another teacher as an education that involves students in learning to do practical work. Gilson said:

What comes to mind when I think of the word technology education is a practical or manual education.

Other teachers with similar views talked about technology education as a course undertaken by students to prepare them for a future career in trades. Zebedee talked about

technology education as being about teaching students the designing and construction procedures appropriate for trade work while at school.

Technology education is about teaching students how to do designing and construction of something in schools and to prepare them for trade work.

Timmy also held the same view of technology education as Zebedee and talked about technology education as learning about modern trades. Timmy specifically referred to technology education as learning about the trades required for constructing modern houses.

Technology education is learning about modern trades that we have today in society. For example, learning about how to build modern houses.

Another teacher, Richard, with a similar view made reference to technology education as the development of human resources in technical fields such as engineering.

Technology education develops human resources in technical areas like engineering, and this is what the country needs which is scarce at the moment.

Of the six teachers who held the view of technology as hands-on activity type of education, three highlighted hands-on activities involving students doing some kind of practical work with their hands, and three perceived technology education to be in line with preparing students for trade work or skilled jobs, including modern trades and engineering.

4.4.2 Technology Education as Creative Activity Education

Two teachers perceived technology education as a creative and innovative type of education. These teachers made reference to creative activity in terms of either the teachers' approaches to teaching or students' approaches to learning. Jason pointed out:

Technology education is about educating students to become creative. Rather than just depending on the teachers for teaching them every thing, the students have to learn to be creative in doing things, so technology education is all about encouraging students to be creative.

A similar view of technology education as a creative and innovative type of education was reiterated by Anthony who believed that technology education was learning about making new things. He commented:

Technology education is basically about learning how to make new things, such as putting new ideas into making new products.

Being innovative in learning and making new things was perceived by Anthony as technology education. He stated that the subject he taught was technology education because the students were always taught how to make something new in class.

As I've mentioned before technology education is my subject [Industrial Arts / Design and Technology] because I'm always teaching students how to make new things.

The two teachers who held this view on technology education as a creative activity type of education talked about creativity in teaching and learning, and also about involving students in making new products based on new and innovative ideas.

In summary, the six teachers who held the view of technology education as hands-on activity education, made reference to teaching and learning that involved doing something by hand practically or manually. The other aspect of this view referred to the preparation students require for trade work or skilled jobs, including modern trades. The two teachers who held the view of technology education as creative activity education made reference to being creative in both teaching and learning in the classroom.

4.5 Teachers' Perceptions of the Value of Technology Education

This section discusses the eight teachers' perceptions of the worth of technology education. They are outlined in three themes: (a) the value of the practical knowledge and technical skills in technology education; (b) the value of technology education for students leaving secondary education; and (c) the value of technology education as an up-to-date education that takes into account new changes in society (see Table 4.4: Value of technology education in the Solomon Islands).

Table 4.4
Value of technology education in the Solomon Islands

| Worth of Technology Education in the Solomon Islands | No. of Teachers / 8 |
|---|----------------------------|
| • Value of practical knowledge and technical skills in technology education | 4 |
| • Value of technology education for students leaving secondary education | 2 |
| • Value of technology education as an up-to-date education that takes into account new changes in society | 2 |

As shown in Table 4.4, four teachers considered the value of technology education in terms of the practical knowledge and technical skills aspects as being useful for making a living in the community, two teachers considered the value of technology education in terms of its significance for secondary school leavers, and the other two teachers considered the value of technology education in terms of keeping up with changes in society. The details of these claims are discussed next.

4.5.1 Value of Practical Knowledge and Technical Skills in Technology Education

Out of eight teachers, four perceived the value of technology education to be practical knowledge and technical skills. The teachers who held this view talked about the significance of practical knowledge and technical skills that students acquired in technology education, which they believed to be useful for making a living in the community. Zebedee pointed out:

The important thing a student should know about in technology education is to acquire the appropriate knowledge and the technical skills in the type of work which they will be doing in the future.

Other teachers who shared this similar view on the value of technology education articulated technical skills as the paramount significant aspect of technology education, and reiterated the usefulness and benefits of technical skills to students for making a living in their community, especially after leaving school. As Ronald explained:

It is very important to assist students while at school with technical skills so that when they leave school they can use these skills in life to help themselves in their own community.

Jason also shared a similar perception and reiterated that technology education empowered students to become useful citizens in their communities as the practical skills they learnt from technology education in secondary schools can be put into proper use later in life. He commented:

What I see as important in technology education is to teach students to become useful in the community, and learning about practical skills, which will become useful to them later in life.

The value of the technical skills aspect of technology education was also perceived as useful later to sustain life in society for those who are currently in paid employment. Anthony pointed out that the skills learnt in technology education were also necessary for survival for employed people, if they were to become redundant one day.

Technology education is important because we will not always be in paid jobs, so technology education prepares us for these kinds of situations and equips us with skills so that we are able to do some things for ourselves when such situations arise.

The four teachers who perceived the value of technology education in terms of practical knowledge and technical skills had focused on three views. First, technology education provided students with practical knowledge and skills which enabled them to do something for themselves in order to make a living in their community. Second, technology education provided students with specific technical skills which would benefit them later in life or after leaving school, and third, the usefulness of technical skills later for those who had to leave paid employment.

4.5.2 Value of Technology Education for Less Academic Students Exiting Secondary Education

Two teachers perceived the value of technology education as preparation for less academic students exiting secondary education to find employment and make a living in society. The teachers who held this view talked about technology education as valuable for students who could not continue to tertiary education or could not complete a full secondary education. Gilson pointed out that only a few students would normally have the privilege of tertiary education, therefore, technology education is considered to be

commendable for the majority of secondary school students without the privilege of tertiary education.

Technology education is very important in our country because not every student that has been through secondary school will get to university, so it is best to offer technology education in secondary schools to cater for that high percentage of students in the country who do not have the privilege to do tertiary education.

Raymond also shared this view and reiterated the significance of technology education for those secondary school students without the opportunity to enter tertiary education.

For us in the Solomon Islands, most students won't go further to university levels. So technology education in secondary schools is very important for this group of students.

The pyramid structure of the educational system in the Solomon Islands provides less space for students as the level of education increases. In this regard, not all secondary school students can complete a full secondary education as many exit secondary education at either the Form Three or Form Five level. Hence, Raymond perceived the worth of technology education as preparing earlier exiting secondary school students for survival and making a living in rural communities.

For us in the Solomon Islands, most students will drop-off in Form 3 and Form 5. So technology education in secondary schools will become beneficial to them and as they go back to their rural areas they will find the skills they've learnt in technology education very useful in life for both survival and to earn a living to continue on with their normal lives.

Both teachers talked about the value of technology education in terms of its usefulness for secondary school students who do not continue into tertiary education and also those who do not complete a full secondary education. Therefore, the value of technology education was perceived by both teachers as a way to acquire technical skills for sustaining life in rural communities.

4.5.3 Value of Technology Education as an Up-to-Date Education that Takes into Account Changes in Society

The other two teachers perceived the value of technology education as a subject for modern times. These teachers believed that technology education takes into account up-

to-date information about the latest technological developments in society. One of the teachers, Timmy, stated that technology is a subject of modern times, therefore technology education should be learning about modern things in our society today.

Yes, technology education is very important because we are now in the modern time, so we need to keep up and learn about the modern technology that we have today.

Another teacher, Richard, with a similar view has also reiterated the idea of keeping up with the changes happening in society. He pointed out:

Technology education is very important to us in the Solomon Islands because there are many changes happening in our time today. Therefore we need to change our programmes so that we can keep up with changes happening today in our society.

Technological developments have brought about changes to modern society which have influenced the views of these two teachers to consider the significance of keeping up with these changes in technology education. Both teachers understood the notion of keeping up with the changes in modern society and the importance of being kept informed about the latest technological developments in society as a significant merit of technology education.

In summary, four of the teachers' perceptions of the value of technology education were mainly focused on practical knowledge and technical skills to prepare secondary school students for survival by making a living in their respective communities. Another two teachers' perceived that the technical skills aspect of technology education was a significant part of technology education for less academic students who may not be able to continue on to tertiary education and also for others who may not be able to complete a full secondary education due to the exit points in Forms Three and Five. The other two teachers made reference to the significance of technology education having up-to-date information in order to keep up with the latest changes in society.

Table 4.5
Summary of teachers' perceptions

| Teachers | Perceptions of technology | Perceptions of indigenous technology | Perceptions of technology education | Perceptions of the value of technology education |
|-----------------|----------------------------------|---|--|---|
| Gilson | is an artefact | is the locally made artefacts | is hands-on activity education | is value for less academic students |
| Richard | is an artefact | is the use of local materials | is hands-on activity education | is keeping up with changes in society |
| Jason | is an artefact | is the locally made artefacts | is creative activity education | is practical knowledge and technical skills |
| Ronald | is making something | is the use of local materials | is hands-on activity education | is practical knowledge and technical skills |
| Anthony | is making something | is traditional way of doing things | is creative activity education | is practical knowledge and technical skills |
| Timmy | is making something | is the locally made artefacts | is hands-on activity education | is keeping up with changes in society |
| Raymond | is applied knowledge | is the use of local materials | is hands-on activity education | is value for less academic students |
| Zebedee | is applied knowledge | is traditional ways of doing things | is hands-on activity education | is practical knowledge and technical skills |

As shown in Table 4.5: Summary of teachers' perceptions, the teachers' views on technology, indigenous technology and technology education and value of the technology education in the Solomon Islands are categorised under a range of themes, and the views held by each individual teacher were somewhat fragmented. However, in general, the teachers' perceptions of technology, indigenous technology, technology education and the value of technology education focused on the use of artefacts, the application of knowledge and hands-on activities involving skills to make artefacts for either sustaining life or improving the quality of life in the community. It thus, validates the need for enhancing the teachers' perceptions of technology and technology education through a professional development programme.

4.6 Teachers' Classroom Technology Activities.

Teachers talked about a range of activities they used in their technology classrooms. These have been categorized into three groups: (a) activities based on procedural notes and practical follow up; (b) activities based on using tools; and (c) activities based on MoE-produced documents (see Table 4.6: Categories of classroom technological activities).

Table 4.6
Categories of classroom technology activities

| Categories of classroom technology activities | No. of Teachers / 8 |
|--|---------------------|
| • Activities based on procedural notes and practical follow up | 2 |
| • Activities based on using tools | 2 |
| • Activities based on MoE-produced documents | 4 |

As shown in Table 4.6, two teachers talked about classroom technology activities based on procedural notes and practical follow up, another two teachers talked about technology activities as being based on using tools, and four teachers talked about technology activities based on the MoE-produced documents. The details of these views are discussed next.

4.6.1 Activities based on Procedural Notes and Practical Follow up

Two teachers talked about their classroom technology activities as having two part lessons: (a) the theoretical part and (b) the practical follow up with hands-on activities. Gilson explained that his classroom technology activities were organised into two part lessons, such as teaching theoretical lessons which were then followed with practical hands-on activities.

Technological practice is not only teaching the note parts of the lessons, but the students also need to do some practical parts by working with the materials. For example, I got my students to learn about arc welding before I gave them some hands-on experience working with the arc welding machine.

Another teacher, Zebedee, also talked about his classroom technology activities as consisting of teaching both the procedural notes and hands-on activities. For example, he

talked about the knowledge students gained from the procedural notes and hands-on experiences acquired from servicing an automobile engine and constructing buildings.

The technology tasks I taught my Form Threes were notes on servicing an automobile engine and notes on building constructions, and the students have also learned a lot from the hands-on activities.

Both teachers made references to teaching of both the procedural notes and practical lessons as they talked about their classroom technology activities.

4.6.2 Activities based on using Tools

Two teachers, Richard and Jason, talked about using tools as their classroom technology activities. Richard talked about his classroom technology activity as the use of tools with supervision.

The technology activities I've got my students to do in Form One were just to identify and describe the tools with very minimum use of those tools. Whenever they use them I have to provide them with intensive supervision. In Form Three I let the students use the tools with moderate supervision during practical classes.

Similarly, Jason also talked about the use of tools as his classroom technology activities. He talked about students using tools at home for undertaking technological tasks.

Sometimes I have to ask the students to do their technological task at home, particularly when they were using indigenous materials. In this case they can use whatever tools they've got available at home.

Both teachers talked about using tools as technology tasks. While one teacher talked about students using tools at school with teacher supervision, the other teacher talked students getting hands-on experiences with using tools at home.

4.6.3 Activities based on the MoE-Produced Documents

Four teachers, Anthony, Raymond, Ronald, and Timmy, talked about their classroom technology activities as based on the MoE-produced documents. Anthony stated that:

My students' technological activities are based on the [Industrial Arts / Design & Technology] curriculum that we currently have which is about making things like tables and other furniture.

Raymond also talked about classroom technology activities as based on the MoE-produced documents. He stated that:

Most technology tasks that we do are mainly focused on wood materials because the current syllabus is focused mainly on woodworking tasks.

Similarly, Ronald reiterated that students gained knowledge and acquired skills from classroom technology activities taken from the MoE-produced documents. As he commented:

Well, with the current Design and Technology curriculum, students learnt knowledge and skills in the woodwork, metalwork, and plastics units taken from the [MoE] textbooks.

The fourth teacher, Timmy, also talked about his classroom technology activities as based on the MoE-produced textbooks. He made reference to the teachers' textbooks produced by the Ministry of Education as he talked about his classroom technology activities.

My technological activities are taken from the topics that are there in the teachers' textbooks.

The MoE-produced document-based activities were mentioned by all four teachers as they talked about their classroom technology activities.

4.7 Teachers' Perceptions of their Teaching Strategies

This section examines the teachers' perceptions of teaching strategies in technology education. These perceptions were categorised into three groups: (a) providing student notes with practical follow-up based teaching strategies; (b) use of MoE-produced document based teaching strategies; and (c) other views of teaching strategies (see Table 4.7: Teachers' perceptions of teaching strategies).

Table 4.7
Teachers' perceptions of their teaching strategies

| Teachers' perceptions of their teaching strategies | No. of Teachers / 8 |
|--|----------------------------|
| • Providing student notes with practical follow-up based teaching strategies | 3 |
| • Use of MoE-produced document based teaching strategies | 3 |
| • Other views on teaching strategies | 2 |

Table 4.7 shows that out of the eight teacher participants, three of the teachers held the view of providing student notes with practical follow-up based teaching strategies; three other teachers held the view of using the MoE-produced documents based teaching strategies, and two teachers held other views on teaching strategies. These three views are discussed in detail in the following section.

4.7.1 Providing Student Notes with Practical Follow-up

Three teachers' perceptions of teaching strategies in technology education were focused on teaching notes followed by hands-on based activity teaching strategies. Ronald explained that his strategy was to teach the related teaching notes then get the students to do a practical project.

I planned my teaching lessons, for example in wood, and a practical part which is also related to those teaching notes. After I've gone through the teaching notes, then I get the students to do the practical project using wood.

Another teacher, Timmy, explained that he organised his teaching approach into two parts as teaching notes and practical.

I organised my teaching lessons to consist of student notes and practical projects and my class lessons were planned according to these two approaches as we learn to make things like types of wood joints, and a flower vase using coconut shells for our technology tasks.

The providing of students' notes with a practical follow-up on hands-on based activity teaching strategy was indicated by another teacher, Zebedee. He explained that he normally asked the students to do design and learn about design-related lessons first before they did the practical part of the task of constructing the designed solution.

I started by getting the students to solve a design problem, and then I asked them to do three different designs. Then they learn about some design-related lessons before they got on to do their practical lesson by constructing their designed solutions.

All three teachers talked about their teaching strategies as those where they provide students with related notes before getting into the practical part of their lessons.

4.7.2 Use of MoE-Produced Documents

Three teachers talked about the use of the MoE-produced documents as teaching strategies in technology education. These teachers made references to the MoE-produced curriculum and the textbooks. Raymond talked about the use of the curriculum guidelines to guide his planning and teaching his lessons:

I've followed the set guidelines given by the curriculum by starting with planning out what is to be done then set the students to carry out those activities. With the junior forms we follow precisely what the curriculum has outlined, but with the senior students, they have to do their own drawings, and just make sure it follows the set of criteria given by the curriculum and that it meets the requirements of our school situation as well.

The use of the MoE-produced documents was again evident in another teacher's comment. Richard stated that he had followed exactly the scheme of work prescribed in the MoE-produced textbooks:

I planned my lessons based on the scheme of work outlined in the teachers' textbook, which outlines the materials, tools and the skills required to construct the projects.

Another teacher, Jason, referred the use of the MoE-produced documents as he talked about his teaching strategies. He reiterated that his teaching strategies were based on the MoE produced textbooks:

I taught my lessons from the textbooks that were given by the curriculum [department of the MoE] and I plan my lessons based on each project as given in the textbook. But even if I have to plan my own classroom tasks, I would still plan them in such a way that related with the unit topics outlined in the textbooks.

All three teachers perceived their teaching strategies in technology education to be based on the use of the MoE-produced documents for teaching their lessons. These teachers

referred to the outlined teaching strategies in the MoE-produced documents for teaching their lessons.

4.7.3 Other Views

Two teachers offered two different views on teaching strategies in technology education. One of the teachers, Anthony, talked about his teaching strategies in terms of brainstorming. He commented that the use of brainstorming techniques led his students to being involved with task selection.

In regard to my teaching strategies and planning, I'm a bit more flexible. I got the students to get into brainstorming first, then we can come up with what the students prefer to do in terms of student projects rather than telling them this is what to do.

Another teacher, Gilson, talked about students working in small groups as one of his teaching strategies. He stated that rotational group work was a teaching strategy he used to get all the students to have a turn at doing each task.

One of my teaching strategies, I got students to work in groups. For example, in arc welding, I got the students to work in small groups and to do certain types of welding, and then they rotate, until everybody had a turn doing all tasks. I also did it in electronics, as one group worked on identifying the different electronic components, the other group was assembling the components together to form a circuit and later they rotate.

These two teachers had two different views as they talked about their teaching strategies in technology education. One teacher talked about a flexible mode where students have their preference in selecting classroom activities, and the other teacher talked about the rotational group working where students have a turn at doing each class task.

A summary of the teachers' classroom technology activities and teachers' perceptions of teaching strategies is given in Table 4.8: Summary of teachers' classroom technology activity and teaching strategies.

Table 4.8

Summary of teachers' classroom technology activity and teaching strategies

| Teacher | Classroom Technology Activity | Perceptions of Teaching Strategies / technological pedagogies |
|----------------|--|--|
| Anthony | Activities based on MoE-produced documents | Other views of teaching strategies |
| Raymond | Activities based on MoE-produced documents | Use of MoE-produced document based teaching strategies |
| Ronald | Activities based on MoE-produced documents | Providing student-notes with practical follow up based teaching strategies |
| Timmy | Activities based on MoE-produced documents | Providing student-notes with practical follow up based teaching strategies |
| Gilson | Activities based on procedural notes and practical follow-up | Other views of teaching strategies |
| Zebedee | Activities based on procedural notes and practical follow-up | Providing student notes with practical follow-up based teaching strategies |
| Jason | Activities based on using tools | Use of MoE-produced document based teaching strategies |
| Richard | Activities based on using tools | Use of MoE-produced document based teaching strategies |

As seen in Table 4.8, there are some similarities and differences in the views held by individual teachers on classroom technology activities and teaching strategies. Two teachers, Raymond and Zebedee, held similar views on classroom technology activities and teaching strategies (see Table 4.8). The other teachers held two different views on classroom technology activities and teaching strategies.

4.8 Teachers' Reflections on Assessment of Students' Learning in Technology Education

This section examines the teachers' reflections on assessment of students' learning in technology education. A range of assessment procedures in technology education were highlighted by the teacher participants, and categorised into three themes: (a) an on-going form of summative assessment; (b) a one-off form of summative assessment; and (c) a form influenced by the curriculum assessment policy (see Table 4.9: Teachers' reflections on assessment).

Table 4.9
Teachers' reflections on assessment

| Teachers' reflections on Assessment | No. of Teachers / 8 |
|---|----------------------------|
| • On-going form of summative assessment | 3 |
| • One-off form of summative assessment | 3 |
| • Form influenced by the curriculum assessment policy | 2 |

As shown in Table 4.9, three teachers reflected on an on-going form of summative assessment, while three others reflected on a one-off form of summative assessment, with two reflecting on the form of the MoE-produced document assessment guidelines. These themes are discussed in detail.

4.8.1 On-going Form of Summative Assessment

Three teachers held the view on assessment in technology education as an on-going form of summative assessment. These teachers talked about the continuous assessment of students' tasks at different stages of working processes. For example, Raymond stated:

I do my assessments during the making period of the projects rather than at the completion of the project.

The other two teachers' on-going form of summative assessment took into account the teachers' continuous assessment of students' work at progressive stages and the assessment of the completed task as well. As Richard explained:

I first assessed the students' drawings, and then I looked at the actual processes involved in the construction of the projects, such as the joints, fastening methods, and finishing. Then I assessed their work based on these processes while they are working and my final assessment comes after the students' projects have been completed.

Gilson also noted that his students' tasks were assessed during the working processes and at the completion stage as well.

I assess the students during their practical work. I assess the students' work through general observations. I assess students' general behaviours in the workshops and how they handle the machines during their practical work, for example, while they're doing welding and I also assess their finished work.

The teachers' on-going form of summative assessment made reference to the assessment of students learning at different stages of students' work and at the completion of each task.

4.8.2 One-off Form of Summative Assessment

Three other teachers held the view of assessing students' learning as a one-off form of summative assessment. These teachers talked about a single assessment of students' work at the completion of tasks. Ronald said:

I don't normally assess my students during the making process, I only assess the students at the completion of their projects.

Timmy was another teacher with the same view. He noted:

The assessments of my students' work are only done after the completion of the students projects.

The third teacher, Jason, talked about assessing his students' work in terms of assignments, homework and unit tests. He commented that he also assessed the students' tasks after he marked their completed tasks.

I gave students assignments and assess that assignment when students hand it in. I also assigned a project for the students to do and then I assess it after they have completed it. At the end of a unit, I also gave the students a unit test, which I marked and assessed the students' knowledge on the [unit] topics.

All three teachers explicitly pointed out that the summative assessment of students learning in technology education was done at the completion of each task. In other words, the assessment was a one-off.

4.8.3 Form influenced by the Curriculum Assessment Policy

The two teachers who reflected on the curriculum document based assessment policy talked about the use of assessment criteria set out in the Industrial Arts / Design and Technology syllabus. Zebedee pointed out that his assessment procedures were based on the assessment guidelines outlined in the MoE-produced documents:

When assessing my students' work, I normally followed the guidelines stated in the curriculum documents.

The criteria from the curriculum documents were used by Anthony as he talked about the assessment procedures he had used:

The assessment criteria that I've used in assessing my students work is outlined in the curriculum documents of the Curriculum Centre [MoE].

The teachers' view on assessment procedures in technology education was influenced by the curriculum document assessment policy. Both teachers specifically referred to the assessment guidelines and procedures outlined in the curriculum documents of the Ministry of Education.

A summary of the teachers' perceptions of assessment practices in technology education is outlined in Table 4.10: Summary of teachers' perceptions of assessment practices.

Table 4.10
Summary of teachers' perceptions of assessment practices

| Teachers | Perceptions of assessment practices in technology education |
|-----------------|--|
| Anthony | Form influenced by curriculum assessment policy |
| Zebedee | Form influenced by curriculum assessment policy |
| Raymond | On-going form of summative assessment |
| Richard | On-going form of summative assessment |
| Gilson | On-going form of summative assessment |
| Ronald | One-off form of summative assessment |
| Timmy | One-off form of summative assessment |
| Jason | One-off form of summative assessment |

4.9 Chapter Summary

This section summarises the 2005 findings related to teachers' perceptions of technology, indigenous technology, technology education, the worth of technology education, technological classroom activities, teaching strategies and assessment practices in technology education. The views teachers held on technology, indigenous technology, technology education and the worth of technology education were varied but narrow. They included technology as artefacts, making something, and application of knowledge. Teachers' viewed indigenous technology as aspects to do with traditional practices in the Solomon Islands, and technology education as technical oriented education. By viewing technology education with a technical oriented education lens, technology education was

perceived by these teachers as suitable for the less academic students and particularly useful mainly for making a living in the rural community. As these teachers had a technical education teaching background, the influences of subject-subculture and background experiences were evident (Jones & Carr, 1992). The findings showed that teachers' knowledge of the nature of technology and technology education were narrow and limited.

Teachers' view of technology education as technical oriented education strongly influenced their views of classroom technology activities and teaching strategies. Teachers associated their existing technical classroom practices with technological pedagogy in technology education. These included textbook-based procedural knowledge for practical activities, and skilful use of tools when undertaking their practical tasks. The teachers' view of assessment focused on assessment of learning. The curriculum assessment policy had a strong influence on the teachers' assessment practices. The difference between summative and formative assessment, and how it was being used in assessing student learning was not clearly understood by the teachers. Thus, it could be argued that a need for a proper understanding of the nature of technology and technology education, understanding of appropriate teaching pedagogy, and understanding of assessment practices for learning are imperative in order for teachers to teach the technology curriculum in Solomon Islands effectively.

Chapter Five discusses the findings of the teachers' teaching materials and the teaching and learning situations in technology education classrooms in 2005. The teachers teaching materials are examined, including the data which is based on classroom observation. Understanding teachers' classroom practice is also crucial for devising appropriate strategies for future development.

CHAPTER FIVE:

TRADITIONAL TECHNICAL CLASSROOM PRACTICES: 2005 FINDINGS

5.1 Introduction

Chapter Four described the teachers' perceptions of technology and technology education. These included the views teachers held on the value of technology education, the classroom technology activities, the teaching approaches and assessment practices used in technology education. This chapter presents the research findings on the teachers' classroom practices in 2005 answering the second part of research question one.

1. What are the teachers' existing views of technology and technology education, and their current classroom practices?

Section 5.2 examines the documents the teachers used: the curriculum documents on which the teachers' teaching lessons were based, and the intended learning outcomes. Section 5.3 describes the teaching and learning situations in the teachers' technology classrooms. It begins with the factors influencing the teaching of theoretical knowledge and technological practices in the classroom situations. Then the teaching approaches in the classroom setting are presented. Teachers' assessment strategies are finally presented. Section 5.4 presents the chapter summary.

5.2 Teachers' Teaching Documents

This section examines the teaching documents used by teachers when they taught their lessons in 2005. A brief overview of each class is presented to set the class context. This is followed by an analysis of the teaching documents. These documents are discussed in two categories based on the curriculum documents and the teachers' own lesson plans. A brief outline of the teachers' anticipated learning outcomes for lesson is presented. This is followed by some examples based on several documents used by teachers when teaching their lessons, before the section summary.

5.2.1 Overview of Each Class

Table 5.1: Class Overview outlines the class levels each teacher participant taught including the number of boys and girls in each class and the total number of students in a class. The table is divided into two categories. The top part of the table provides data from the teachers teaching in the senior secondary levels, and the bottom part of the table provides data from the teachers teaching in the junior secondary levels.

Table 5.1:
Class overview

| Teachers Teaching in the Senior Level (Form 4) | | | |
|---|--------------------|---------------------|--------------|
| Teacher & Class Levels | No. of Boys | No. of Girls | Total |
| Raymond's Form Four | 9 | 4 | 13 |
| Ronald's Form Four | 15 | 2 | 17 |
| Anthony's Form Four | 19 | 4 | 23 |
| Gilson's Form Four | 18 | nil | 18 |
| Teachers Teaching in the Junior Levels (Forms 1 & 2) | | | |
| Teacher & Class Levels | No. of Boys | No. of Girls | Total |
| Timmy's Form Two | nil | 63 | 63 |
| Richard's Form Two | 23 | nil | 23 |
| Zebedee's Form Two | nil | 45 | 45 |
| Jason's Form One | 24 | 26 | 50 |

Table 5.1 shows that four teachers were teaching senior secondary classes while another four teachers were teaching the junior secondary classes. The junior class range included one Form One class and three Form Two classes. There were four Form 4 classes in the senior category. The class sizes ranged from the smallest with 13 students in Raymond's Form Four class to the largest with 63 students in Timmy's Form Two class. As Industrial Arts is compulsory at the junior secondary level in all schools, the class sizes are generally large. The class capacity is generally reduced to smaller sizes at the senior secondary level as Industrial Arts / Design and Technology shifts from being a compulsory to an optional subject. Gender was unbalanced in all classes, though it varied for each class. In Ronald's Form Four class of 17 students, there are only 2 girls and 15 boys, while Anthony's

Form Four class of 23 students has 4 girls and 19 boys. In some schools the classes are gender stream-based, which means a class would consist of either all boys or all girls. For example, Zebedee's class of 45 students were all girls, as was Timmy's class of 63 students. In other schools, Industrial Arts is a compulsory subject for all boys at junior secondary level. For example, all 23 students in Richard's Form Two class were boys. The gender imbalance in these classrooms was influenced not only by school policies, but also by student choice. At the senior secondary level, Industrial Arts/Design Technology is offered as an optional subject. Hence, all 18 boys in Gilson's Form Four class had chosen to take Industrial Arts/Design Technology as their optional subject. The most evenly gender balanced class was Jason's Form One class of 50 students, which had 26 girls and 24 boys. Altogether, the proportion of boys to girls in taking technology is high.

5.2.2 Ministry of Education (MoE)-Produced Materials

Teachers used the Ministry of Education (MoE) textbooks as teaching prescriptions which meant they used prescribed lessons taken from the MoE textbooks. A typical page from a MoE textbook is shown in Figure 5.1: Photocopied notes from MoE textbooks. The content included notes on the topic, either on manual tools, or materials and a diagram for illustration purposes. The prescribed content also included a set of homework questions for each lesson and technical words were listed in glossary format.

Figure 5.1
 Photocopied notes from MoE produced textbooks

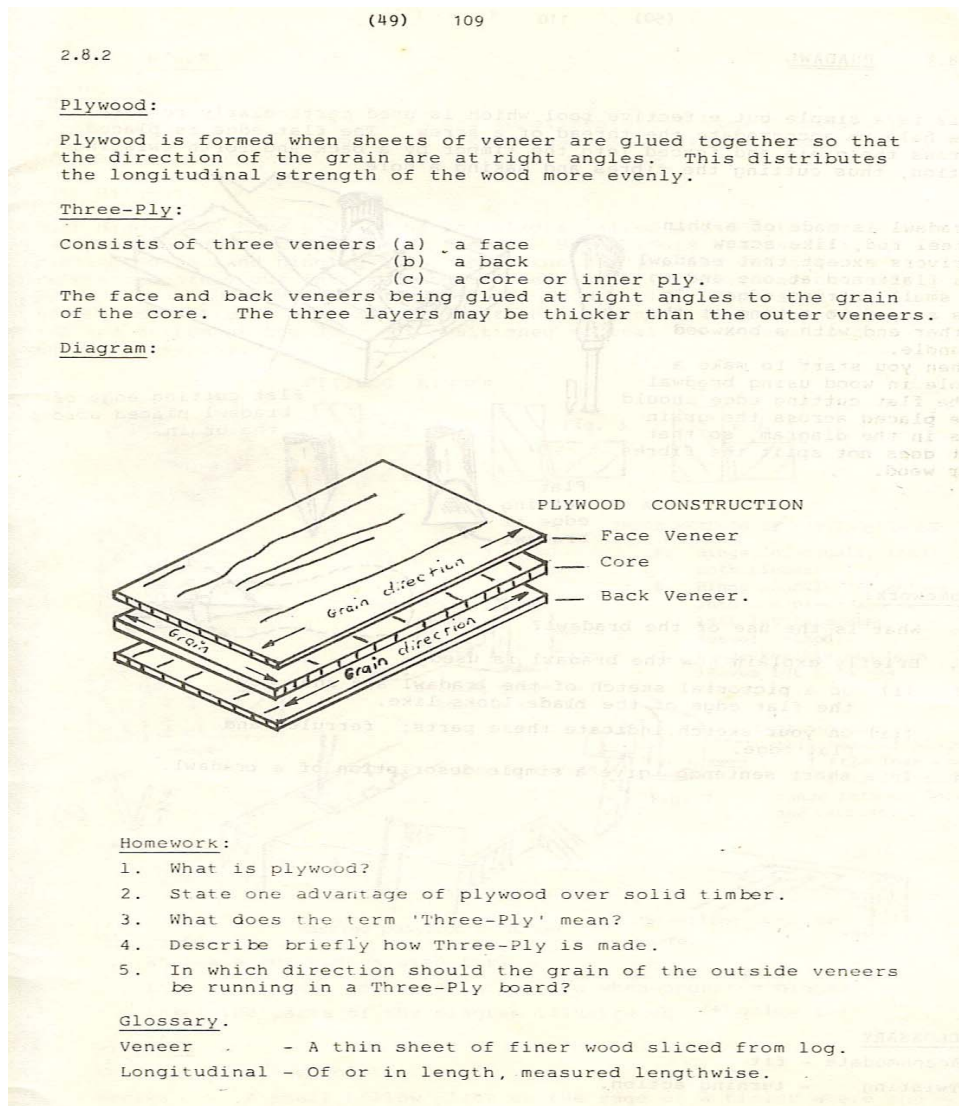

The content prescribed in the Industrial Arts Form One and Two student MoE textbooks was used by all junior secondary class teachers to teach their lessons. The Industrial Arts textbooks for both Form One and Two contain predominantly technical drawings and information on hard materials, (wood, metal, and plastics) with more emphasis on wood. Electronics is included in the *Industrial Arts/Design Technology Syllabus* (MoE, 1990) and is used by the senior forms. The lessons taught by the junior secondary class teachers were based mainly on the use of hard materials (wood), the use of tools (woodworking tools) and technical drawings in the *Industrial Arts Form One Student Book* (MoE, 1988) and *Industrial Arts Form Two Student Book* (MoE, 1988). The lessons taught by the senior secondary class

teachers were based on electronics, hard materials (metal), and technical drawings. The teacher's lessons used predominantly hard materials. Out of the 16 lessons observed, 12 lessons were hard material related lessons, while two lessons were on technical drawing, and two lessons were on electronics.

Every teacher was observed twice, and both lessons taught by four of the teachers were directly taken from MoE produced textbooks. Timmy's two lessons were from the *Industrial Arts Form Two Student Book* (MoE, 1988). His lesson on technical drawing was from page 14 (see detail in Figure 5.2) and his lesson on hammers was from page 37 (see detail in Appendix J). Zebedee's two lessons were taken from the *Industrial Arts Form Two Student Book* (MoE, 1988) as well. His lesson on hammers was from page 37, as was Timmy's lesson on hammers (see detail in Appendix J); and his plywood lesson from page 49 (see detail in Figure 5.1). Jason based both lessons on screws and screwing on pages 39 and 40, (see detail in Appendix H); from the *Industrial Arts Form One Student Book* (MoE, 1988). Ronald used the *Form Four Technical Drawing Exercise textbook* (MoE, 1985) page 9 (see detail in Appendix I) to teach both his lessons on technical drawing. These curriculum documents were the basis for all planning and teaching content.

Figure 5.2
A Form Two technical drawing exercise (*Form Two Industrial Arts Students Book, p.14*)

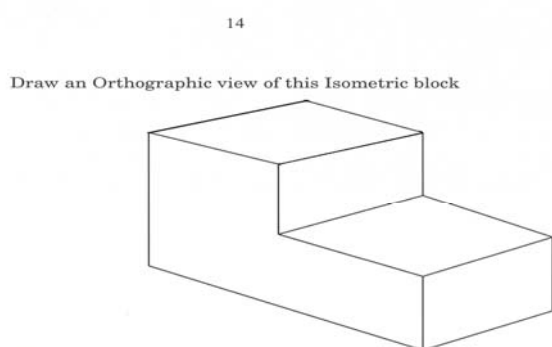

A clear example of how the teachers were strongly influenced by the textbooks was demonstrated when two teachers from two different schools taught the same lessons at the same time and used similar approaches when they used the same textbook. Timmy and Zebedee both taught the lesson on hammers around the same time, and

used almost the same approach depicted in the *Industrial Arts Form Two Student Book* (MoE, 1988). Their similar approaches for telling students how to use a hammer are evident in the excerpts taken from Timmy and Zebedee's class lessons on hammers.

This is how to hold the claw hammer when you are driving a nail into the wood; and when removing a nail with the claw of the hammer always use a block of wood between the timber and the head of the hammer to avoid bruising the piece of timber. (Timmy)

When driving a nail into the wood, hold firmly to the handle of the hammer... and when removing a nail from the wood, use the claw of the hammer. (Zebedee).

All the junior secondary class teachers' lesson sequences were similar because the teachers teaching the same classes forms followed the same lesson sequences outlined in the Forms One and Two Industrial Arts textbooks.

5.2.3 Teachers' Individually Developed Teaching Materials

Four other teachers Raymond, Anthony, Gilson, and Richard, developed extra support materials for teaching their lessons rather than teaching directly from the MoE produced textbooks. Raymond's Form Four lessons were based on the *Form Four and Five Design and Technology Syllabus*, which focused on the types and properties of metal and the procedures for joining metal. The types of metals included ferrous and non-ferrous metals, and the properties of metal included colour, hardness, brittleness, elasticity, conductivity, tenacity, and malleability. The procedures of joining metals included, seams, riveting, soldering and welding. As the Ministry of Education did not have a set of prescribed textbooks on metalworking, Raymond had to photocopy a set of notes on these topics from other resource books (see detail in Appendix K). These photocopied notes were given to each student in his class to use as reference notes.

Anthony's lessons were also based on the *Form Four and Five Design and Technology Syllabus*. One of his lessons was a combined focus on development drawing and the construction of a product. The lesson focused on how to form a cone shape, which could also be used as a base for the development of a funnel, bucket or basin. Figure 5.3: Anthony's lesson outline is a photocopy of this lesson.

Figure 5.3
Anthony's lesson outline

Lesson 19 FORMING DEVELOPMENT.

LEARNING OUTCOME: At the end of the Lesson the student will be able to form development for: Bucket, basin and Funnel.

It takes three stages:-

- To form an elevation
- To form big and small circle.
- To cutout the development.

Procedures:

Decide or find a height: - 100mm.

Decide or find a diameter - 80mm.

Draw a line vertically to the height.

Draw the diameter on the top of the line.

Take the half the diameter on the top to make it as diameter for the bottom.

From the diameter on the top draw the outside circle.

From the half the diameter on the top or from the diameter at the bottom draw the inside circle.

Find the centre of the circle and divide it into half.

Allow seams around the development Selected.

Cut the development out.

(a) Elevation

(b) Circle

(c) Development

Outlined in Figure 5.3 is Anthony's teaching plan. It includes the learning outcomes he wanted students to achieve, the stages for forming the development, and the working procedures for students to follow when undertaking the development plan in forming the cone. All the students were instructed to follow these prescribed procedures, and consequently, all the paper cones developed by students looked exactly the same (see Figure 5.4).

Figure 5.4
Students' paper funnel projects in Anthony's class



In another school, Gilson created his own student worksheets as support for teaching his Form Four Design and Technology electronics class about identifying resistor values (see Figure 5.5), even though the Ministry of Education has produced a prescribed textbook for electronics.

Figure 5.5
Gilson's lesson on identifying the values of resistors

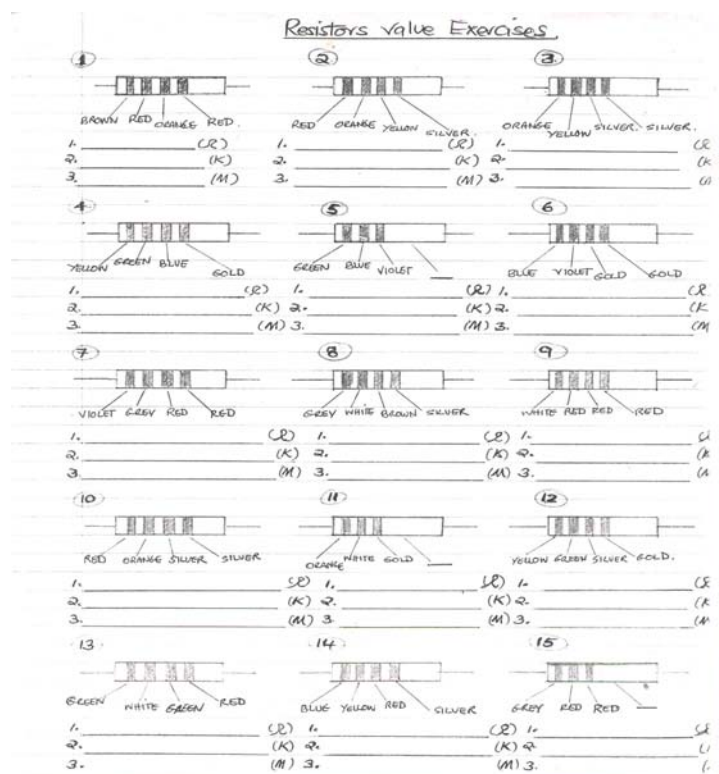

Gilson's student worksheets contained 15 different fixed resistors exercises with a range of labelled colour stripes along each side. This worksheet was given to each student and they were instructed to identify the values of the resistors by writing the numbers that each colour represents on the blank lines. Consequently, every student's answer was the same, as the total values for each of the 15 resistors were identified.

Although the Form Four textbook produced by the Ministry of Education has set projects for students to undertake as practical lessons, Richard also did not use the set curriculum produced materials to teach both his practical lessons. Instead, he based both of his practical lessons on a project - making a file tray which he designed himself. Figure 5.6 is an isometric view of Richard's file tray.

Figure 5.6
Isometric view of Richard's file tray design

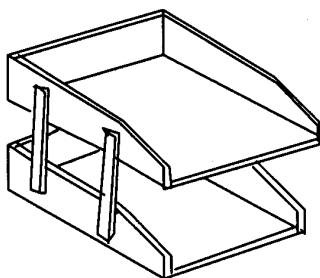

The isometric view of the file tray design was drawn on the blackboard (as shown in Figure 5.6) for students to follow. Richard also used a ready made file tray as a basis for giving students instructions. The students were instructed to use the exact measurements of the file tray displayed as their guide for constructing their individual file trays. By undertaking this practical project, the students were doing almost the same tasks as they were instructed to make a file tray that looked exactly like that shown in Figure 5.7.

Figure 5.7
Student's work in Richard's class



There were two main sources on which the teachers' lessons were based, either the MoE textbooks or their own planned lessons. A summary of the teachers' lesson sources is outlined in Table 5.2: Teachers' Lesson Sources.

Table 5.2:
Teachers' lesson sources

| Teachers | MoE-Textbook Based Lessons | Teachers' Own Planned Lessons |
|-----------------|-----------------------------------|--------------------------------------|
| Anthony | | X |
| Jason | X | |
| Richard | | X |
| Timmy | X | |
| Raymond | | X |
| Ronald | X | |
| Gilson | | X |
| Zebedee | X | |

Table 5.2 Teachers' Lesson Sources shows that four teachers based their lessons on the Ministry of Education and the other four teachers based their lessons on personally developed teaching approaches. Three of the four teachers who based their lessons on the MoE textbooks were teaching at the junior secondary level. Out of the other four teachers who developed their own lesson plans, three were teaching at the senior secondary level.

5.2.4 Teachers' Learning Outcome Considerations

Of the eight teachers, only one indicated his learning outcomes through a written teaching plan and the other seven teachers revealed their learning outcomes verbally through an interview prior to their lessons, where they identified the learning outcomes that they anticipated for their students from each lesson. For example, Timmy said:

By teaching this lesson, the students should be able to differentiate between a claw hammer and the other types of hammers, and be able to explain its uses and be able to name the various parts of the claw hammer.

Jason also explained the learning outcomes he hoped to achieve:

I'm expecting the students to be able to understand the types of screws and be able to name the screw parts.

Raymond shared his learning outcomes as he walked into the classroom. He commented:

From this unit, students are expected to understand the various types of metals, under ferrous and non-ferrous metals, and the processes involved in working with metal materials.

While waiting for the students to turn up in class, Ronald stated that:

From this lesson, the students should be able to complete their drawings from the previous class, and be able to draw the dimensional lines and add dimensions to their drawings.

As students were working on the given task, Gilson commented:

My objectives are basically for students to identify the colours on the resistors and to calculate the values of the resistors by using the resistors' colour coding diagram. The students should also be able to convert the values of the fixed resistors back into the colour coding system.

Likewise, Richard also commented during class while students were working on their file trays:

The objective of this task is to make a file tray for the teachers to use in their offices.

Jason stated before class that:

By the end of class students should be able to understand the types of screws and be able to name the screw parts.

Of the other teachers, Anthony was the only one to have a written plan of his learning outcomes. He recorded that:

At the end of this lesson, students will be able to form a development for a bucket, basin and funnel (as seen in Figure. 5.3).

A summary of the teachers' learning outcomes is given in Table 5.3: Teachers' learning outcomes.

Table 5.3:
Teachers' learning outcomes

| Teachers | Learning Outcomes |
|-----------------|---|
| Anthony | Students will be able to form a development for a bucket, basin and funnel |
| Jason | Students will be able to understand the types of screws and be able to name the screw parts |
| Richard | To make a file tray for the teachers to use in their offices for keeping papers |
| Timmy | Students will be able to differentiate the difference between a claw hammer and the other types of hammers, and be able to explain its uses and be able to name the various parts of the claw hammer diagram |
| Raymond | Students are expected to understand the various types of metals, under ferrous and non-ferrous metals, and the processes involved in working with metal materials |
| Ronald | Students should be able to complete their drawings from the previous class, and be able to draw the dimensional lines and add dimensions to their drawings |
| Gilson | The students should be able to identify the colours on resistors and calculate the values of the resistors by using the resistors' colour coding diagram. The students should also be able to convert the values of the fixed resistors back into the colour coding system |
| Zebedee | Understand the types of plywood |

Most of the learning outcomes were expressed verbally by teachers during an interview; only one teacher had written learning outcomes. The learning outcomes

were based on acquiring skill knowledge and hands-on experience. Out of the sixteen lessons observed, eight were based on acquiring knowledge while eight were based on acquiring hands-on experience. Teachers who taught theoretical lessons stated that their learning outcomes were focused on acquiring knowledge. Teachers who taught practical lessons stated that their learning outcomes were focused on acquiring hands-on experience.

5.2.5 Working Procedures as Key Feature of the Lessons

The focus of most lessons was on procedures for making something. Students were expected to know and follow procedures when using a particular tool and also when undertaking a practical task. The students were to follow predetermined and laid out procedures. These procedures, if followed, would culminate in students making an artefact. For example, Anthony had written notes on the blackboard giving step-by-step procedures that students needed to know and follow in order to construct the paper funnel (as seen in his lesson plan in Figure 5.3). Ronald, who taught a technical drawing lesson, had notes on the blackboard emphasizing the procedures the students needed to set up technical drawing papers onto the drawing boards and also step-by-step procedures for centring the actual drawings on the A3 size paper. His procedures were outlined as:

- *setup the A3 size paper and draw margins of 10 mm right around the paper*
- *then draw the title blocks and fill in the necessary details, such as your names, date and scale*
- *calculate the horizontal spacing and the vertical spacing*
- *then draw the orthographic view*

In another lesson, Raymond based his explanations on the processes involved when working with sheetmetal. He explained the working procedures step-by-step as required for joining sheetmetal with rivets as outlined in his photocopied notes in Figure 5. 8.

Figure 5.8
Step-by-step procedure for joining sheet metal with rivets

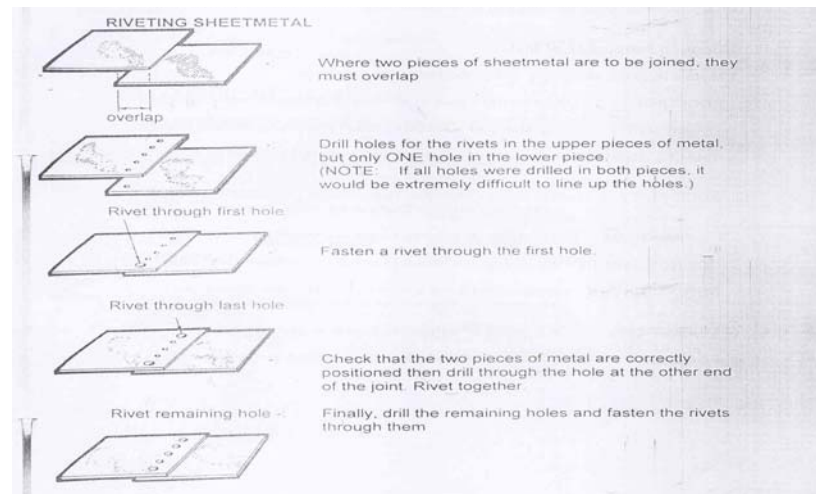

Figure 5.8 is an outline of the step-by-step procedures used for joining sheetmetal using rivets. The procedures are illustrated with drawings with an explanation of each step.

The curriculum documents used by teachers also contained notes on working procedures. For example, Jason's photocopied notes from the *Industrial Arts Form One Textbooks* (MoE, 1988) contained notes on proper procedures for using screw drivers on screws (see Appendix H), and so in his lessons emphasised this process. Based on the Industrial Arts textbook content, Zebedee's lesson illustrated the working procedure for constructing a rebate joint as seen in Figure 5.9.

Figure 5.9

Lesson on steps to construct rebate joint as outlined in the Industrial Arts Form Two textbook

- B. END to EDGE with sides flush or fitting together. This is used in making frames, such as picture frames or frames for coconut scrapers, easily and cheaply.

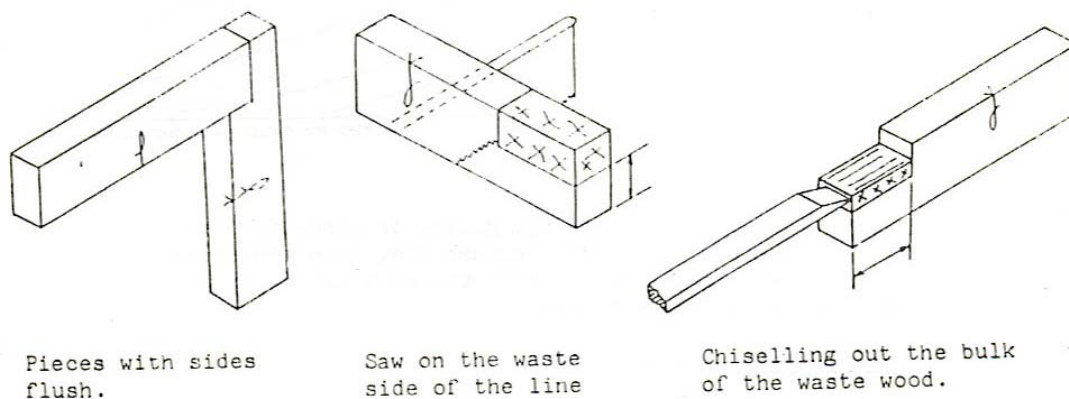

The procedures emphasised in the teachers' lessons were either based on a process involved in manufacturing a product, or a process involved in acquiring a technical skill. These procedures resulted in students accomplishing their technical tasks by following the teacher, step-by-step.

5.2.6 Summary of the Teachers' Teaching Documents

The first part of this chapter described the documents used by teachers for teaching their lessons. Of the eight teachers, four used the MoE Industrial Arts textbooks for the prescribed teaching lessons. The other four used their own lesson plans. Interestingly, of the four teachers who used the MoE textbooks for their lessons, three of the teachers taught in the junior secondary classes. Only one teacher taught in the senior secondary level. In contrast, of the four teachers who planned their own lessons, three teachers taught classes at the senior secondary level. Only one of these four teachers taught in the junior secondary level. While the teachers did not reveal their written learning outcomes, they were able to reveal them verbally. Of the sixteen lessons, the learning outcomes of eight lessons focused on knowledge and understanding, and the learning outcome of the other eight lessons focused on hands-on experiences.

Section 5.2 has described working procedures as the predominant content of the lessons. The content of both the textbook-based lessons and the individual teachers' own lesson plans focused on working procedures, or step-by-step procedures for students to follow when undertaking tasks.

5.3 Teaching and Learning Situations in Technology Classrooms

This section examines the teaching and learning situations in the technology classrooms. Section 5.3.1 examines the factors influencing teachers' teaching of theoretical knowledge and technological practices. Section 5.3.2 examines the narrow technical approaches to the teaching of technological practices. These technical approaches included closed tasks and prescribed theoretical lessons on manual tools. Section 5.3.3 describes the teacher-dominated teaching approaches, textbook-oriented teaching approaches, classroom-confined teaching approaches, and teaching without considering students' prior knowledge and experience. The assessment strategies used by the teachers are outlined in section 5.3.4 and cover both formative and summative assessment. Section 5.3.5 provides a section summary.

5.3.1 Factors Influencing the Teaching of Theoretical and Practical Lessons

The influences on teaching theoretical and practical lessons are examined from three aspects. Firstly, the school timetables, secondly, the school circumstances, and thirdly, the teachers' preferences.

School timetables

The arrangement of the timetable for teaching Industrial Arts / Design Technology in all the schools showed the school influence on teaching theoretical and practical lessons. Table 5.4 indicates the participant teachers' timetable for teaching Industrial Arts / Design Technology.

Table 5.4:
The teacher participants' teaching timetable for teaching Industrial Arts and Design Technology

| Teacher/Class | Monday | Tuesday | Wednesday | Thursday | Friday |
|----------------------|---------------|----------------|------------------|-----------------|---------------|
| Timmy / F2G | | | Period 6 | Periods 2&3 | |
| Anthony / F4 | Period 6 | | Periods 7&8 | Periods 7&8 | |
| Zebedee / F2G | | Periods 1&2 | Period 2 | | |
| Ronald / F4 | Periods 3&4 | | Periods 7&8 | | Period 3 |
| Jason / F1 | Periods 3&4 | | Period 1 | | |
| Richard / F2R | | Period 1 | Periods 3&4 | | |
| Gilson / F4 | | Periods 5&6 | Periods 7&8 | | Period 8 |
| Raymond / F4 | Periods 7&8 | Period 5 | | | Periods 4&5 |

The timetable shows that three periods were allocated for the junior secondary classes (Forms One to Three) and five periods were allocated to the senior secondary classes (Forms Four and Five). Each teacher's timetable was arranged into two sets of class periods, single or double. The length of the single period was 40 minutes and the double period was 80 minutes. All teachers had a single period and a double for the junior classes, and two doubles for the senior classes. The single periods were for teaching theoretical lessons while the double periods were for practical lessons.

The separation of theoretical and practical lessons was partly influenced by the school timetable. Teaching theoretical knowledge in isolation from practical lessons was a common practice for all the teachers involved in this research study.

School circumstances

School circumstances experienced by two teachers, Raymond and Jason, also influenced their teaching of theoretical and practical lessons. Although the arrangement of both teachers' timetables was basically catering for the teaching of theoretical lessons and practical hands-on lessons, both teachers experienced difficulties in teaching practical lessons. For example, Raymond found it difficult to teach the practical lessons he intended because his school principal did not purchase

the materials requested for the students' practical tasks. Because he did not have the materials, he could only teach the theoretical aspects of the curriculum. As he pointed out:

Most of the time, I taught theoretical lessons only because every time I asked my principal to buy us the materials for the practical classes, he often gave me the excuse of no money.

In another school, Jason only taught theoretical aspects because he did not have practical facilities (workshop classroom and manual tools) in his school. He commented:

In my school I don't have a workshop and tools to teach the practical lessons, so all that I can do is just to teach the theoretical side of the curriculum.

Neither teacher could deliver the practical aspects of the curriculum due to their school circumstances, which included no practical facilities in the school and no provision of materials for practical work. In both cases, practical lessons were not undertaken. Therefore, the two teachers used both the single and double periods to teach theoretical lessons only.

Teachers' preferences

Teachers' preferences also had an influence in determining which theoretical lessons would be taught in the single periods and which practical lessons would be taught in the double periods. Five teachers preferred to teach related theoretical and practical lessons. In other words, their two lessons were linked. For example, both of Richard's practical lessons were on making file trays, and Jason's two theoretical lessons were on screws and screwing (see Appendix H). Raymond taught two theoretical lessons on metal processing, while Gilson taught two theoretical lessons on identifying electronic values (see Figure 5.5). Ronald, had planned to teach his second lesson on wood structure, which was different from his first lesson on technical drawing. However, due to the late start of his class, he changed from his initial plan and decided to continue with the previous technical drawing lesson. He stated:

I was going to give a theoretical lesson on wood structure to this class but seeing that I've only got 10 minutes left for this class, I'll ask the students just to continue with their technical drawing from their last class.

In contrast, three other teachers, Anthony, Zebedee, and Timmy, taught two consecutive lessons which were totally unrelated. For example, Anthony taught a theoretical lesson on the procedures for funnel making (see Figure 5.3 and Figure 5.4) in his first lesson, and in his second lesson, he taught a practical lesson on making a bookend support. Zebedee taught a theoretical lesson on plywood (see Figure 5.1) and a practical lesson on how to make a rebate joint using solid wood (see Figure 5.9). Timmy taught a theoretical lesson on claw hammers (see Appendix J), and in his second lesson, he took a technical drawing lesson on converting an isometric view of a block step into an orthographic view (see Figure 5.2). While some teachers preferred to teach two connected theoretical and practical lessons, other teachers preferred to teach two unrelated separate lessons.

5.3.2 Narrow Technical Approach to Teaching and Learning Technology

The technological practices undertaken by the teachers were mainly focused on a narrow technical approach, rather than on broad technological practices. The practical tasks were closed tasks. In other words, the practical tasks were prescribed tasks designed by the teachers or taken from the curriculum textbooks, and the students were to follow exactly as teachers prescribed. The theoretical lessons were predominantly based on the use of manual tools and lessons were based on worksheets. The illustrative examples on the worksheets outlined a step-by-step approach and students followed these steps exactly as asked.

Closed Tasks

The teachers' practical lessons were mainly focused on students getting hands-on experience in making something and acquiring skills. Anthony's practical tasks were how to make a funnel and a bookend. Richard's practical task was on making a file tray and Zebedee taught a practical lesson on making a rebate joint. These practical tasks were undertaken by the students according to the prescriptions outlined, and they followed the procedures outlined by the teachers or the curriculum textbooks. The practical tasks were closed tasks, in that only one outcome / artefact / product was to be made following a recipe-type process. Therefore, all the students' projects looked very much alike. For example, in Anthony's practical lesson on funnel making, all the students made a funnel exactly the same as that made by the teacher (as shown in Figure 5.4). Exact instructions on

the working procedures (see Anthony's lesson plan, Figure 5.3) were given to each student for making the paper funnel model. The students followed these procedures and therefore, at the end of the task, all students' paper funnel models looked exactly alike.

In Zebedee's class the students worked towards achieving the prescribed task of making a rebate joint set out in the curriculum document. The drawing seen in Figure 5.9 was used as a blueprint for construction that students were to follow. Zebedee's objective was to give the students some hands-on experience with some woodworking tools such as the handsaw and chisels. By making a rebate joint, students would have the required hands-on skills for making a rebate joint and using handsaw and chisels. The hands-on experiences were undertaken as Zebedee expected. At the end of the class, the students' rebated joints looked exactly like the one prescribed in Figure 5.9.

The technical drawing exercises in the curriculum textbooks were also prescribed and were presented as closed tasks. When teachers taught technical drawing, they expected the students to follow the technical drawing procedures exactly as prescribed. For example, Timmy's Form Four students did an orthographic drawing that they converted from the isometric view shown by the teacher (see Figure 5.2). They followed the step-by-step procedures exactly as prescribed. Consequently, all the students' final drawings looked basically the same. The prescribed tasks in the curriculum textbooks and the teachers' lesson plans were closed tasks where only one outcome was expected.

Prescribed theoretical lessons

Teachers' theoretical lessons were taught in isolation from the practical tasks. A prescribed step-by-step approach was used by three teachers for teaching their theoretical lessons. Jason, Zebedee and Timmy all taught prescribed theoretical lessons on manual tools. For example, Jason taught lesson on screws and screwing (see Appendix H) taken from the *Industrial Arts: Form One Student Book* (1988). Photocopied notes on screws were given to the students at the beginning of the class. In the photocopied handout, a labelled diagram of a screw was included. The students examined this and responded to Jason as he asked for their help to label the

parts of the screw diagram he had drawn on the blackboard. The following is an excerpt from Jason's conversation with the students:

Jason: What is this part of the screw called? [He points to the diagram on the blackboard]

Jimmy: The head

Jason: Good [as he writes it on the blackboard at the end of the arrow pointed to the head of the screw.] What is this part called? [He points to the other end of the screw]

Patrick: [looks at his notes.] The point.

Jason: Good [writes the word again on the black board.] What is this middle part called?

Paul: [After looking at his handout notes.] The threads.

Jason: Good [continues to label the parts of the screws on the blackboard.]

The students took their answers from the prescribed photocopied handout given to them at the beginning of the class. The handout was used as a reference for the correct answers.

In another theoretical lesson, Timmy brought two claw hammers into his classroom. He explained the use of the claw hammer and passed them around the classroom for the students to examine. He explained to the students that he wanted them to copy blackboard notes and at the same time examine the claw hammer:

Timmy: As you continue to take down the notes on the blackboard I'm passing round two claw hammers to the two students here in front to pass around the class, and as it gets to you, I'd like you to have a close look at it, and get a feel of how it can be used.

Students: [The first two students pick up the two hammers and start flipping them around, while the whole class continues copying notes from the blackboard].

Zebedee asked students to identify various woodworking tools (try square, saw, hammer, marking gauge and chisels) as he placed them on his table. The following conversation is an excerpt of the dialogue he had with his students:

*Zebedee: Could anyone identify a marking gauge for me?
[Esther raises her hand]*

*Zebedee: Thank you
[Esther comes to Zebedee's table and looks at the tools. She does not identify the marking gauge]*

Zebedee: Could we have another student to help her?

Mary: Here it is. [Points to marking gauge]

*Zebedee: Thank you, and can you hold it up so the rest of the class can see it?
[Mary holds up marking gauge]*

The students did exactly as Zebedee asked. All the examples above illustrate closed tasks and the use of a prescribed step-by-step approach. The students did exactly what was asked of them by the teachers. No opportunities were given for the students to reason out things for themselves, or to suggest divergent solutions.

5.3.3 Teaching Approaches

This section describes the teachers' teaching approaches used in 2005. These are discussed as teacher-dominated teaching, teaching confined to textbooks, teaching confined to classroom settings, and teaching without considering students' prior knowledge and experience.

Teacher-dominated teaching

The teacher-dominated teaching approach had two facets. First, student tasks were directed by teachers, and second, teachers' instructions were to be precisely followed by students. In most of the lessons, the teachers used instructions to direct students about what to do when they undertook activities. Several teachers, Timmy, Anthony and Richard, told their students about the tasks they were to undertake before the tasks were undertaken. For example, Timmy introduced the technical drawing exercise to the class by giving students instructions on what to do. He said:

Our exercise for today is a technical drawing as you can see in the handout given to you. The exercise is drawn in an isometric view and you are going to redraw it into an orthographic view.

Second, Anthony taught a lesson on funnel model making. He told his class to follow the instructions he had outlined on the blackboard. He instructed thus:

I'm going to give you a piece of paper to make the funnel and I'd like you to follow the instructions as outlined on the blackboard.

The teachers' outline notes and instructions were followed by students. The instructions were the working procedures that students had to follow to undertake the prescribed tasks. Richard highlighted that by following such guidelines the potential for making errors would be minimised. He explained to his students that:

You have to follow the instructions I have given you, but if you are not sure, please let me know before you start working because I'm not going to give you any new materials if you make any mistakes.

In this teacher-dominated form of teaching, the teachers' instructions were used by students as a recipe for undertaking the prescribed tasks.

Teaching confined to textbooks

The textbook-oriented teaching approach was also a teacher-dominated form of teaching. Most classroom tasks undertaken by students were prescribed tasks, which were taken directly from the textbooks (see Appendices H, I, J, & K). In these cases, the students' learning was very structured and tightly confined, as they were directed to learn from the textbook contents exactly as prescribed.

Three teachers, Timmy, Jason and Zebedee, based their lessons on the textbooks. Timmy based his on technical drawing from the *Industrial Arts Form Two Students Book*. Zebedee's theoretical lesson on plywood was from the same textbook. Jason's photocopied notes on screws and screwing was taken from the *Form One Industrial Arts Students Book*. The following examples are excerpts from their lesson introductions:

Our lesson for today is on technical drawing. So could you turn your textbooks to page 14 where the exercise for today is? (Timmy)

Get your textbooks out and turn to page 109. Our exercise for today is about plywood so follow the notes as I go through it for you. (Zebedee)

Here are your photocopied notes on screws and screwing from your textbook. (Jason)

The textbooks were used by these teachers as recipe books which they relied on for selecting students' classroom activities and teaching notes.

Teaching confined to classroom settings

The classroom was the only setting for teaching and learning. Every teacher confined all their lessons to the classroom setting. All 16 lessons, both practical and theoretical, were taught by the teachers themselves in their respective classrooms. No lessons were linked with community enterprises, or exposed students to any technological community practices. All teaching and learning occurred within the classroom walls regardless of the accessibility to numerous enterprises surrounding the schools.

Teaching without considering and taking into account of students' prior knowledge and experience

Students' prior knowledge and experience were ignored by teachers when teaching their lessons. Teachers taught as if the students knew nothing. For example, Gilson taught his electronic lessons as if the students had never learnt about resistors before. At the beginning of the class, Gilson did not ask the students about what they had already knew about resistors. Instead, he began the class by telling the students that the values of the resistors were normally identified by the colour bands around each resistor. As he explained:

There are two types of resistors. First is the fixed resistor and second is the variable resistor. The value of the fixed resistor is identified by the colour band around the body of the resistor.

Gilson's explanation was a reiteration of what some students already knew. The following is my conversation with one of the students while he was identifying the values of the resistors.

Researcher: Have you learnt about the resistor before?

Jimmy: Yes

Researcher: Where did you learn about resistors?

Jimmy: In our Form Three science

Researcher: Did you know that resistors values are normally identified by the colour bands?

Jimmy: Yes, from our Form Three science class last year.

Researcher: So what's the difference between the electronics you have learnt in science and the electronics you are now learning in technology?

Jimmy: Well, in science we only learned about the theory side as we are doing now. But in technology, I'm hoping to see the practical side of it.

In teaching this lesson Gilson did not take into account the students' prior knowledge of electronics. The electronic lesson seemed to be a repeat of a science lesson previously taught in Form Three.

Another teacher, Timmy, used questioning at the beginning of the class to find out about the students' prior knowledge of the claw hammer when teaching the lesson on claw hammer. The following is an excerpt of the students' responses to Timmy's question:

Timmy: What is a hammer use for?

Annette: Hammer is used for hitting a nail into the wood.

Grace: It is used for nailing timbers and removing nails from a piece of timber with the claw of the hammer.

After the two students' had called out their answers consecutively, Timmy then went on and explained the use of the claw hammer, as if the students had not contributed. He said:

The claw hammer is used for driving nails into the wood and for removing nails from a piece of wood with the claw of the hammer.

Timmy's explanation was a reiteration of the two students' previous comments. The students' responses were not acknowledged by Timmy. The following excerpt is from the same lesson and is a conversation I had with two students while two hammers were passed around Timmy's classroom:

Researcher: Have you seen this tool before?

Shelly: Yes, I have.

Researcher: Where did you see it?

Shelly: At home, my Dad has a hammer.

Rita: I've already used a hammer before.

Researcher: What did you do?

Rita: I used it when I nailed my mosquito net onto the wall at home.

This conversation revealed that these two students had prior knowledge and experience of a claw hammer. Timmy taught the lesson as it was prescribed without reference to students' ideas or experiences. Towards the end of this lesson Rita said: "I have not learnt anything new because I'm already familiar with this lesson on hammers". Therefore, in teaching this lesson, Timmy did not take into account the students' prior knowledge and experiences.

5.3.4 Teachers' Assessment Practices

The teachers' assessment practices are examined under two categories. First, their formative assessment practices, and second, their summative assessment practices.

Formative assessment practices

Formative assessment practices between teachers and students were one-sided. For example, when Raymond interacted with students through questioning, he often did not get any response from students. When this happened he supplied the students with the answer to his question. For example:

Raymond: Can anyone define the term metal for me?
Students: No response.
Raymond: Would anyone like to have a try?
Students: Silence.
Raymond: Metal is a by product of iron ore mixed with carbon.

The students became silent especially when being questioned by the teachers in a whole class situation. In some classrooms, the silence was because students were not attending to the teacher's questions, as they were still copying notes from the blackboard. For example, in Anthony's class, no student responded to his questions after his demonstrations of how to make a funnel model from an A4 size paper:

Anthony: Have you understood what to do?
Students: Silence [Students are copying notes]
Anthony: Does anyone have any question regarding what to do?
Students: Silence [Students are still copying notes]
Anthony: Make sure you follow the steps as I have outlined on the blackboard for making your funnel.

Similarly, in Timmy's class, when students were busy drawing the diagram of the hammer they did not respond to his question.

Timmy: Do you have any questions regarding the use of the claw hammer?
Students: Silence
Timmy: Now you can draw the diagram of the claw hammer in your exercise books.

Some teachers' interactions with students followed a teacher Inquiry, student Response and teacher Evaluate (IRE) approach. The teachers asked the students to think of only one right answer. They evaluated with a positive response if the students' answers were correct. The following example is an excerpt from Timmy's conversation with his students as they labelled the diagram of a hammer drawn on the black board:

Timmy: What is this part of the hammer called? [The teacher points to the part of the hammer he is holding in his hand]
Cathy: The head.
Timmy: Good [as he writes it on the blackboard at the end of the arrow pointed to the head of the hammer.] What is this part called? [He points to the other part of the hammer]
Kerry: The claw.
Timmy: Thank you [he writes the word again on the black board.] What is this wooden part called?
Leticia: The handle.
Timmy: Okay. Now you know the parts of the hammer.

Similarly, in Gilson's conversation with his students as they identified the values of the resistor drawn on the blackboard, he only asked the students to give him the one right answer. The following is an excerpt from Gilson's conversation with his students:

Gilson: From the diagram of the fixed resistor which is drawn on the board, let's identify the values from the colours marked on the resistor. What colour is the first band?

Peter: Red.

Gilson: What value does red represent?

Peter: Two.

Gilson: What colour is the next band?

James: Blue.

Gilson: Good. What value does orange represent?

Kelly: Six.

Gilson: What colour is the third band?

Martin: Orange.

Gilson: What value does green represent?

James: Three zeros.

Gilson: What is the fourth colour on this resistor?

Peter: Gold.

Gilson: What does gold represents?

Peter: It represents the resistor's tolerance in %.

Gilson: How much tolerance does gold represent?

Kelly: Five %.

Gilson: Overall, what can we say is the total value of this resistor?

Teacher and students, together: 2600 ohms and 5% tolerance

With this type of questioning approach, the students' answers were limited and straight to the point. Students' ideas were not pursued, as the questions asked were closed questions, and the students' answers were limited to what the teachers asked for. The nature of these conversations illustrated a tell-the-teacher questioning type.

When teachers walked around the classroom to check on students' work, the conversation between teachers and students were also teacher-dominated. Students' conversations were limited to when they had questions to ask the teachers. Students asked the teachers when they were not sure of doing something. The teachers' responses seem to take up most of the student-teacher conversation. The following was from Anthony's conversation with a student:

Patrick: Teacher, how do I use this chisel?

Anthony: Okay, to remove the waste from the plywood, you have to turn your chisel with the bevel edge facing you in order to have a clean cut. This is how you do it. [demonstrates how to use the chisel]

Patrick: [picks up the chisel from the teacher and does as instructed as he starts chiselling]

Anthony: That is how to use the chisel, so that you won't tear off your plywood as you can see from your work now.

Similarly, in Gilson's electronic class and Ronald's technical drawing class, students' conversations with the teacher were limited to the questions students asked of the teacher. In response to students' questions, Gilson and Ronald dominated the conversation. The following are excerpts of Gilson and Ronald's conversation with their students:

Thomson: How do I convert the ohms into kilo ohms?

Gilson: Okay. To convert the ohms into kilo ohms, you have to know how many ohms in a kilo ohm. There are 1000 ohms in a kilo ohm. So if you have a resistor with the colour band of brown, which represents 1, and green which represent 5, and orange which represent 3 zeros, then you would say that this resistor has 15000 ohms. Then you divide this 15000 by 1000 and you will get 15, which is 15 kilo ohms. That is how you convert ohms into kilo ohms. Do you get that?

Thomson: [nods his head]

Gilson: It's just that simple.

Thomson: Thank you teacher.

Christie: Teacher, I still don't understand how to calculate the horizontal spacing and the vertical spacing.

Ronald: Okay. You just have to use the measurements outlined on the blackboard. To position your drawings using horizontal spacing, you start with 61.6mm from the edge of the paper then add 215mm, the length of the elevation, then add another 61.6mm, then add 75mm, the width of the end elevation and then add another 61.6 at the end and you should have your drawings positioned at equal spacing horizontally. For the vertical spacing, start with 16.6mm from the edge of the paper, then add 75mm, the width of the plan, then add 16.6mm again, then add 75mm, the height of the end elevation and you should have another 16.6mm left at the end of the drawing and the vertical edge of the drawing paper. Do you think you can do that?

Christie: Thank you, I'll try.

The teacher-student one-on-one conversations were teacher-dominated. As the teachers moved around the classroom assisting individual students, the students' questions seemed to focus on seeking further demonstration and clarification of

something they were not sure of. In response to students' questions, the teachers appeared to dominate the conversations.

Summative assessment practices

Teachers' 2005 summative assessment practices are discussed in two parts. Firstly, the informal assessment practices and secondly, as a formal form of summative assessment.

Informal summative assessment

Informal summative assessment practices refer to the approach undertaken by the teachers when they spot-checked students' understanding of the lessons as they were being taught. These approaches included the use of recall questions, the checking of the task undertaken by students in the classroom, and, other approaches.

- *The use of recall questions*

Two teachers used recall questions as a means to spot check students' understanding of their lessons. For example, towards the end of Timmy's lesson on the claw hammer, he asked these recall questions:

Timmy: Mary, would you explain the use of the hammer?

Mary: The use of the hammer is for nailing timbers.

Timmy: Good, and Susan, what is this part of the hammer called? [as the teacher points to the part of the hammer in his hand]

Susan: The claw.

Timmy: That's correct.

Timmy's recall questions were directed to specific students, identified by Timmy as the quiet students in his class. Timmy reasoned that if the quiet students responded correctly to his recall questions, then the smarter students would also have been able to understand the lesson. As he stated:

My learning outcomes have been achieved because when I asked the quiet students at the end of the class they responded to my questions correctly. Therefore, I knew that the smarter students would easily understand the lesson.

Another teacher, Jason, used recall questioning at the beginning of his teaching lesson to recall his previous lesson on screws. For example:

Jason: What is the advantage of screws over nails?

Student: Screw threads provide a better holding power than nails.

Jason: Good, it seems that you have studied your photocopied notes.

The student's recall explanation of the advantage of screws over nails was Jason's evidence that his learning outcomes of the previous lessons had been achieved.

Jason commented:

I know my learning outcomes have been achieved because the student responded with the right answer to the question I asked earlier at the beginning of the class.

These two teachers used recall questioning as a means to assess students understanding of their lessons. The recall questions were asked at the beginning and towards the end the lessons.

- *Checking the task undertaken by students in the classroom*

Checking the tasks undertaken by students in the classroom was another form of informal summative assessment used by teachers for assessing the students understanding of their teaching lessons. Two teachers, Timmy and Gilson, said that they knew their students understood their teaching because they observed the students undertaking the tasks. In Timmy's technical drawing lesson, he pointed out that his teaching lesson was well understood by the students as he saw that the task was done exactly as he expected. He stated:

My learning outcomes for this lesson have been achieved because I've seen the students do exactly as I expected. They have drawn an orthographic view from the given isometric view.

In Gilson's electronic lesson, he pointed out that the students completed the task in accordance with his expectations. He commented:

I have seen what I had expected from the students' work and they did exactly as I had instructed them to do. They have written the values after identifying the colours.

Both teachers assessed students' understanding of their lessons based on their observations of how well the students completed the tasks.

- *Other approaches used by other teachers as spot checks*

Two other teachers talked about other approaches they used to check students understanding of their teaching. Jason indicated that he assessed student understanding of the lesson by giving them time at the end of the lesson to ask any questions. For example:

Jason: Has anyone got any questions regarding our topic today?

Class: [No response - Silence for about three minutes. Jason scans the class for questions]

Jason: OK. This is the end of the class, and you can get ready for your next teacher

Jason reasoned that students ask questions if they are puzzled, therefore, the silence in the classroom indicated that the lesson was understood by the students as no one asked him questions. He explained:

The silence in the class at the time I asked the students to ask any questions regarding the lesson means that my lesson was well understood by the students.

Another teacher, Raymond, said that the learning outcomes were achieved because he covered the teaching content within the allocated time. As he said:

My learning outcomes had been achieved because I have covered everything in the handout that I have given the students in the class period.

These were the teachers' views of their informal approaches for finding out how their teaching lessons were understood by students.

Formal approaches to summative assessment

Formal summative assessment approaches included the use of written tests and the assessment of students' work.

- *The use of written tests*

Two teachers, Raymond and Timmy, indicated that they used written tests at the end of the unit as their assessment approach. Raymond said:

I would need to give my students a written test based on this unit to be really sure that they have understood this lesson.

Timmy also used a similar approach to summatively assess the learning outcomes. He said:

I'm going to give a test at the end of this unit in order to know whether the students have understood this lesson.

When both teachers taught theoretical lessons they said they would use a written test at the end of the unit for assessing students' understanding of the ideas in the theoretical lessons.

- *Assessment of students' tasks after completion*

The teachers who taught practical lessons and technical drawing lessons, indicated that they would assess their students' work after completion. For example, after Anthony's paper funnel making practical class, he asked his students to hand in their completed paper funnel model to be assessed. He said:

Could you leave your completed funnels on my table before you go to your next class so that I can assess them?

Timmy also indicated that he would collect the students' work for marking after class and assess the students' finished drawings. He commented:

I'm collecting the students' exercise books to check their work, particularly the measurements. After I've done that I would redraw the orthographic view on the board for the students to see and correct their own work if they did not get it right the first time round

The teachers' formal summative assessment practices were influenced by the nature of the tasks undertaken in the classroom. The teachers' who taught theoretical lessons said that they would assess students' understanding of the lesson by giving them written tests. The teachers who taught practical and technical drawing lessons said that they would assess students' work on completion.

5.3.5 Summary of the Teaching/Learning Situations in Technology Classrooms

The second part of this chapter described the teaching and learning situations in the technology classroom. The teaching of theoretical lessons and practical tasks separately was highlighted due to the influence of the school timetables and other circumstances experienced by some teachers in various schools, and individual teachers' preferences. The narrow technical approach to teaching of technology included the use of closed tasks and the following of step-by-step prescriptions in teaching how to use manual tools. Several issues were highlighted with teachers'

teaching approaches. Firstly, the teachers' teaching approaches were very much teacher-dominated where teachers' instructions were used as student guides for undertaking class tasks. Secondly, the textbook teaching approach was a teacher-dominated teaching approach. Thirdly, all teaching was confined to the classroom setting with no links made with community enterprises. Fourthly, the students' prior knowledge and experience were not considered in teaching approaches. The teachers' formative assessment was described as one-sided and teacher-dominated while the summative assessment was limited to only a few classroom activities.

5.4 Key Findings of Chapter 5

Teaching documents are predominantly prescribed

The teachers' teaching documents were mainly based on the prescribed MoE textbooks or teacher prepared teaching documents. Both types of teaching documents were predominantly prescriptive, with teachers using them as recipe books on which their teaching lessons were based.

Teachers' learning outcomes were not clearly outlined or written

Almost all the teachers' learning outcomes were not written, as most of the teaching documents were based on the MoE textbooks which did not have clear learning outcomes outlined. Therefore, the teachers' learning outcomes were verbally expressed and based on the prescribed document content.

Teachers' teaching notes were prescribed mainly as working procedures

Most of the teachers' teaching documents contained notes emphasising either a process involved in manufacturing a product, or working procedures involved in acquiring a technical skill. The teaching of particular procedures was also emphasised in most of the teaching lessons. Both teaching documents and practices emphasised particular working procedures.

Fragmented teaching of theoretical and practical lessons

All the teachers taught their theoretical lessons separately from their practical lessons. This practice was influenced by two factors. Firstly, the school timetable organization meant that teachers had no choice but to organise their teaching

lessons to fit in with the arrangement of the school timetables. Secondly, the lack of administration support, and lack of facilities and equipment experienced by the teachers from various schools caused difficulties in teaching the theoretical knowledge and practical hands-on experience activities together.

A narrow technical teaching approach to technology

Most teachers' teaching approaches focused on a narrow technical approach to technology. The teachers' practical tasks of hands-on experiences were closed tasks and confined to the outlined prescriptions in the textbooks. The students undertook the closed tasks by following outlined procedures exactly as prescribed. Hence, on completion, all the students' projects looked very much alike as all students did almost the same thing. The students' theoretical lessons were also prescribed by a step-by-step approach.

Teaching approaches

The teaching approaches included teacher-dominated teaching approaches, textbook-oriented teaching, teaching confined to the classroom setting, and, teaching without considering students' prior knowledge and experience.

- *Teacher-centred focus teaching approaches with less student input*

The teacher's teaching approaches were mostly teacher-centred, focused so that students did not have much input on how a task should be done. Almost all the students' tasks were teacher-driven and students followed precisely the teachers' instructions as required. These were used as the only student guide to follow for undertaking the given tasks.

- *Textbook-oriented teaching*

About half of the teacher participants based their teaching lessons on curriculum produced textbooks. Therefore, most classroom tasks undertaken by students were prescribed tasks which were taken directly from these. The students' learning was very structured, and tightly confined as they were directed to learn from the textbook contents exactly as prescribed.

- *Teaching confined to classroom settings*

Every lesson occurred inside the classroom. The classrooms were used as the only site for teaching and learning. None of the lessons had links with any community

enterprises, or exposed students to any technological community practices, despite the accessibility of numerous enterprises surrounding the schools.

The teachers' assessment practices

The teachers' assessment practices were discussed under the two themes of formative and summative assessment.

- *Narrow understanding of formative assessment*

The teachers had a narrow understanding of formative assessment. Their interactions were one-sided on the teachers' part with students rarely responding to the teachers' questions. The students' responses were very limited, as most of the teachers' questions were closed questions. The teachers' questions asked for students respond only one right answer. The formative interactions in the classroom did not pursue students' ideas.

- *Limited approaches to summative assessments*

The teachers' summative assessment is discussed under informal and formal forms of assessment. The informal form of summative assessment involved the teachers' spot checking the students' understanding of the lessons being taught. The teachers used the following approaches for summatively assessing students: the use of recall questions; checking on students' understanding of the given tasks; assuming that students would ask questions when they did not understand something; and covering the content within the given time. More formal forms of summative assessment were limited to two approaches: assessing students completed tasks, and giving students a written test. Theoretical lessons were assessed by using a written test and the outcomes of the practical tasks were assessed after the completion of the task.

The findings of Chapter Five confirmed that teachers' classroom practices were also technical education oriented, matching the views they held on technology and technology education. Therefore, enhancing these teachers' understanding of the nature of technology and technology education, and their understanding of technology teaching pedagogy may also influence their classroom practices in order to teach the technology curriculum as intended. Chapter Six presents the accounts of the professional development intervention programme undertaken by teacher

participants during the second phase of the research study as the strategy employed in assisting teachers develop a better understanding of the nature of technology and technology education, and basically to help improve their classroom practices in teaching the technology curriculum as intended. The key approaches used for the professional programme are discussed along with the professional development programme and the outcome of the teachers' involvement.

CHAPTER SIX:

TEACHER PROFESSIONAL DEVELOPMENT: More than Technical

6.1 Introduction

Chapter Five described the findings related to teachers' classroom practices in teaching technology education in 2005. The findings revealed that their teaching documents and classroom practices were very traditional. Their teaching styles were teacher-dominated and text-book oriented with a narrow technical approach to teaching technological practices. The student tasks were closed-ended and the theoretical knowledge and technological practice were taught in a non-integrated manner. The shortcomings of assessment included formative assessment practices often being one-sided, teacher-dominated conversations, and summative assessment focused mainly on the final products and memory testing. The findings of Chapters Four and Five established the basis for the professional development (PD) programme which was undertaken in 2006.

This chapter discusses the findings based on data analysed from the PD programme undertaken by the technology teacher participants in 2006. The PD programme took into account the localised context in the Solomon Islands, best practices, including the use of appropriate pedagogies in teaching technology, and enhancing teachers understanding of the nature of technology and technology education. This professional development intervention programme was a means of enhancing the teachers' perceptions of technology and technology education, and subsequently changing their classroom practices. The first part of the chapter discusses the key principles underpinning the PD programme, and the impact on teachers' professional development, both during the workshops and in the classroom. The second part of this chapter discusses the activities undertaken in all three workshops and their impact on teachers' views of technology and technology education, and planning for classroom practice in technology education. The findings revealed that teachers were able to establish a common understanding of technology and technology education, and were able to plan technology lessons. The technology lesson plans were based on best practice in

technology education. This chapter also briefly highlights the effectiveness of a new pedagogical approach for these teachers where they reflected on, and shared their classroom experiences with colleagues during workshops two and three. The discussion is then completed with a chapter summary.

6.2 Key Principles underpinning this Professional Development Programme

This section discusses the key principles underpinning the PD programme undertaken by the technology education teacher participants in this study. The key principles considered effective for PD programmes elsewhere were adopted in this case. These principles were ongoing PD, the learning through reflection approach, and teacher support (Bell, B, 2005; Bell & Gilbert, 1996; Jones, 2003; Jones & Moreland, 2004) including the sharing of classroom experiences. The incorporation of these strategies aimed to enhance the technology education participant teachers' existing concepts of technology and technology education and their traditional teaching approaches. The PD programme also aimed to move teachers forward and away from their 2005 views and their more traditional teaching approaches (Jones, 2001; Jones & Moreland, 2004).

In regard to specific technology education PD, there are three underlying factors for developing and delivering the PD programme to the technology education teacher participants of this study in the Solomon Islands. These were to help teachers develop a robust concept of technology and technology education, to understand technological practices (Jones, 2003), and to develop a greater understanding of the nature of technology and associated pedagogical content knowledge (PCK) (Jones & Moreland, 2004).

6.2.1 On-going Nature of the Professional Development Programme

The PD workshops for technology teachers in this research study were structured to reflect an ongoing nature. The PD programme was designed with the workshop days alternating with classroom practice sessions as seen in Table 6.1: Professional development structural programme overview.

Table 6.1:
Professional development structural programme overview

| Workshop One Two Days | Classroom Practice Six Weeks | Workshop Two One Day | Classroom Practice Six Weeks | Workshop Three One Day |
|--|--|---|--|---|
| - Enhancing teachers' concepts of technology and technology education. - Planning for effective technology teaching | - Trialling of the technology units teachers had developed | - Reflection: Enhancement of teachers' concepts of assessment for effective technology planning | - Trialling of the technology units teachers had developed | - Reflection on and evaluation of the entire teacher professional development programme and classroom practices |
| Term 3 | → | | Term 4 | → |

As shown in Table 6.1, the PD programme was organised into three workshops. The first two workshops were conducted in term three, and the third workshop in term four of 2006. The first workshop was undertaken over two days with a focus on enhancing teachers' concepts of technology and technology education and planning for effective technology teaching. This was followed by six weeks of classroom teaching with the facilitation of the PD provider. The second phase of the PD was undertaken after the first six weeks of classroom teaching. The second workshop was undertaken in one day and focused on reflection and the enhancement of teachers' concepts of assessment for effective technology planning. Another six weeks of classroom teaching was undertaken, again with support. This was followed by another one day workshop to conclude the PD programme. The third workshop was for reflection and evaluation of the entire PD programme and classroom teaching.

The structure of the PD programme was organised so as to reflect an on-going approach to PD. It also aimed to build on each workshop session and in between classroom sessions to monitor teacher change (Bell, 1993; Bell, B, 2005; Jones, 2003; Jones & Compton, 1998). One of the teachers, Richard, pointed out that this ongoing nature of PD was a worthwhile approach for professional growth in teaching technology. He commented:

It's also good that we can have another workshop coming up so that we can expand more on our views of technology and learn more to help us with our teaching of technology. I'm always looking forward to those workshops. (25/7/06)

The on-going approach to PD also encouraged teachers to put into practice the things they learnt in the first two workshops. For example, Anthony pointed out that the teachers might

neglect the new ideas learned during the workshops if they were just a one-off kind of workshop. He explained:

If it was only a one-off kind of workshop, I don't think all these teachers will be keen to trial these new ideas. I guess maybe only some keen teachers would like to do it but with the rest, I think they will forget about it and just continue with their own things. (27/7/06)

Zebedee expressed similar sentiments and pointed out that having another workshop was significant for feedback purposes. He said:

I'm looking forward to the next workshops so that some of my questions and the things that I don't quite understand can be clarified. (22/8/06)

The views shared by these three teachers on the ongoing nature of the PD reinforced the worthwhileness of the PD approach. From these teachers' points of view, the ongoing PD structure had motivated them to try something new and also enhanced their professional growth.

6.2.2 Teacher Support Approach to Professional Development

The teacher PD programme was in itself a form of teacher support, aimed to assist teachers cope with curriculum change. Other forms of teacher support inherent in the PD programme included teachers talking to each other (Bell, 1993; Bell, B, 2005; Bell & Gilbert, 1996), and the facilitator being available to teachers during the PD programmes and classroom teaching.

Teacher support during workshops

The support provided during workshops by the researcher/facilitator, included the presentation of technological concepts, guidance of teacher discussions, and assistance of teachers with the writing of lesson plans. Richard commented that the teacher support provided during the workshop was very helpful in getting him to gain a better understanding of the educational aspects of technology. He stated:

The workshop has helped me to understand the educational aspect of this subject called technology. Now I am able to identify a technological task, plan a teaching lesson and be able to teach it. (24/7/06)

Example lesson plans were provided as another form of teacher support when teachers were planning their technology lessons in workshop one. The details of these example lesson plans are discussed later under workshop one. Both the example lesson plan formats were given to teachers as guides to support them in planning their own technology lessons. Zebedee pointed

out that these lesson plan formats had helped a lot in terms of planning technology lessons and also in teaching it. He commented:

These lesson formats have helped me to plan my work clearly and it's very easy to follow in teaching the lesson. (24/7/06)

Another form of teacher support provided to teachers during the workshops was the teachers' sharing their teaching experiences with colleagues (Bell, 1993). The PD programme was ongoing and had three workshops alternating with two sessions of classroom practice. By having workshops after classroom teaching, the teachers had opportunities to share their teaching experiences and interact with other colleagues. The time given to teachers during the workshops to share with each other helped them support each other, and also helped them to develop common concepts (Bell, B, 2005; Jones & Moreland, 2004). The sharing opportunity enabled teachers to ask questions and to learn from their colleagues' classroom experiences. The teachers' shared experiences were valued by two teacher colleagues as a form of teacher support and a learning process for them. One of the teachers, Zebedee, pointed out in workshop two that sharing classroom experience stories with other colleagues was a learning process. He said:

As I'm new to this kind of teaching approach I would like to let the other teachers share their experiences first because I've been interested in hearing what they were doing in their own schools. Now that I've heard from my colleagues I'm looking forward to trying out some of my colleagues' ideas with my classes. (27/8/06)

Ronald shared similar sentiments in workshop three as he stated:

By listening to my colleagues I've learnt that their main tasks are basically to solve problems, or to address a need in the society today. Technology education is the process in which the teachers and students follow as a tool basically to solve the problems of today's society. (26/10/06)

School visits as backup support

Visiting teachers at their own schools and providing teachers with classroom assistance while trialling their technology lessons was another form of teacher support. This support was provided by the researcher during classroom lessons on a regular basis to enhance the teachers' confidence in adjusting to new situations (Jones, 2003). During the school visits, the PD provider normally intervened in classroom situations to assist the teacher participants with their classroom tasks. Timmy pointed out that this kind of support was very helpful in a classroom situation, especially when they were stuck. He commented:

Your visits to our school are very helpful. For example, the questions you asked the students in class today helped me to see what I need to do in order to move them forward. (22/8/06)

Richard also appreciated the school visits as a way of helping and validating his classroom practice. He stated:

I always look forward to your school visits because your visits have helped me to see whether I am doing the right thing or not. I always like you to come and visit our school as I don't mind. In fact the more visits you do the better for me I think. So please do come around our schools and assist me with my work. (15/8/06)

The school visits were also used as an opportunity to clarify queries and doubts on aspects teachers learnt during workshops. The following excerpt was from Zebedee and the PD provider's conversation:

Zebedee: Whenever I knew you were coming to our school I always prepared my questions to ask you.

Researcher: What sort of questions do you have?

Zebedee: I'd like to know what exactly I have to do under the societal learning outcomes.

Researcher: That is what you want your students to do in regard to what others think about the project they are making. In other words, you need to get your students to gather information from the users on what they think of this particular project. For example, the students need to find out the opinions of those people who will be using this stool, which are the students and staff on what they think about the stool.

Zebedee: Thank you, now the question I have on the lesson plan has been answered and now I understand the lesson plan a bit better. (23/8/06)

Ronald also favoured the school visits and viewed them as an opportunity to be with the researcher on a one-to-one basis for discussion. He commented:

The continued visits that you had done to our schools were good because we have more time to talk about things. Also in your visits I may express my views fully to you on an individual basis. (27/8/06)

These four teachers viewed the school visits as an opportunity for getting extra help with their classroom teaching. The school visits were appreciated by teachers as a strategy to back up their classroom practice.

6.2.3 Role of the Professional Development Provider

The researcher was also the PD provider who facilitated the three workshops and visited the teachers during their classroom teaching sessions. In each workshop, the PD provider took on

the role of the presenter and also the role of the chairperson when facilitating discussions. In the hands-on activity sessions, the PD provider worked alongside individual teachers with their lesson plans. During the classroom practice sessions, the PD provider undertook repeat visits to each teacher to provide backup support as teachers trialled their technology activities in their classrooms. The nature of the PD approach enabled the PD provider to provide teachers with ongoing support both during the workshops and during their classroom teaching. Teacher support was a crucial feature and it strengthened teachers' confidence as they trialled the new teaching approach and it helped put them at ease as they adjusted to new situations (Jones & Moreland, 2004).

6.3 Professional Development Programme

A teacher PD programme was undertaken in the second phase of this research inquiry (see Figure 6.1: Research inquiry structure). The PD programme is discussed in this section. The impact of the PD programme on teachers' change of perceptions of technology and technology education, and classroom practices are discussed separately in Chapter Seven. Before this PD programme, the participant teachers' only experience of PD was related to the development of curriculum documents, which were usually week-long workshops. None of these teachers had experienced any PD directed to the development of their own knowledge or practice. Therefore this PD was a first for the participant teachers. As a consequence of this being a first, I decided to develop a programme that was very supportive for these teachers.

Figure 6.1
Research inquiry structure

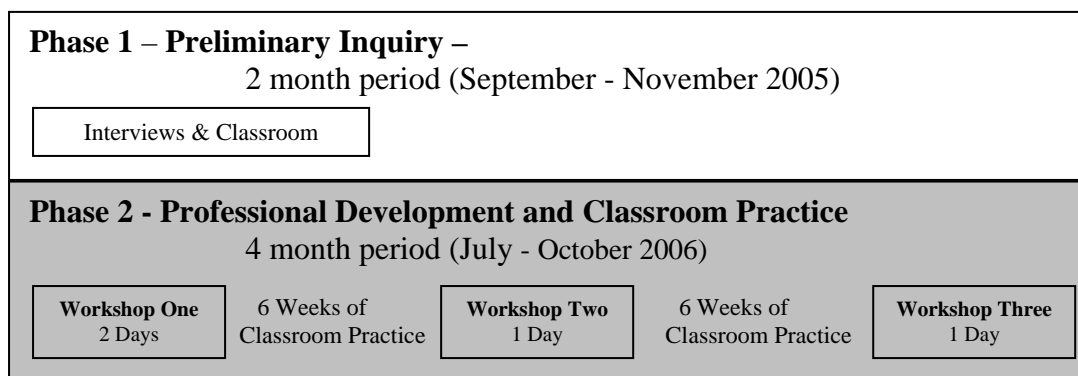

As shown in Figure 6.1, there were three workshops, and two sessions of classroom practice occurred between the workshops. This section presents the programmes for the three

workshops. Each workshop is presented sequentially with a summary table of each session. A content summary and the outcomes of each workshop are also presented followed by the teachers' and the researcher's evaluation of each workshop.

6.3.1 Workshop One

The teachers' first workshop was undertaken over two days. Each day had four sessions (see Table 6.2: Overview of the sessions of Workshop One) with each session lasting for an hour and half. The first workshop was designed so that teachers had opportunities for reflection and lesson planning.

Table 6.2:
Overview of the sessions of Workshop One

| Day One of Workshop One | | | |
|--|--|--|---|
| Session 1 | Session 2 | Session 3 | Session 4 |
| Teachers reflected on their own and others' perceptions of technology and examined a range of definitions of technology from different authors, including a range of technological issues within the Solomon Islands | Teachers viewed and reflected on a video on technological problem-solving – <i>What Noise Annoys</i> | Teachers reflected on their own and others' perceptions of technology education. Teachers also examined a range of technology curriculum and learning theories including the socio-cultural theory of learning in technology education | Teachers viewed and reflected on a video on technological practice in the classroom – <i>Tuakau College</i> |
| Day Two of Workshop One | | | |
| Session 1 | Session 2 | Session 3 | Session 4 |
| Teachers were given a lecture on becoming an effective technology teacher and the outcome-based learning approach | Teachers designed their unit lesson plans for trialling | Teachers continued designing their unit lesson plans for trialling | Wrap up and evaluation |

As shown in Table 6.2, the first day of Workshop One was focused on the enhancement of teachers' perceptions of technology and technology education, while the second day was focused on writing their technology lessons plans to be taught in semester two in 2006. The sessions on Day One were focused on examining their own and others' perceptions of technology and technology education, and viewing two video clips based on technology

practices; one in the community and the other in the classroom. On Day Two, teachers were involved in planning their lessons for teaching in semester two of 2006. A brief outline of the activities undertaken in the two-day workshop is presented next.

Content outline of teacher activities of Workshop One

The four sessions on Day One of Workshop One were focused on discussing the question *What is technology and technology education?* The first two sessions were focused on the first part of this question, *What is technology?* and the two last sessions were focused on the second part of the question, *What is technology education?* In session one, the teachers examined their own and their colleagues existing views of technology (refer Chapter Four), which were gathered from interviews in 2005. The teachers' existing views of technology were presented on PowerPoint and also as handouts. This session provided the teachers with an opportunity to reflect on their own and their colleagues' views of technology. As teachers reflected on these views on technology, they then realised that not all the teachers shared the same views. Jason pointed out that by being aware of the range of views teachers held of technology had raised a need to establish a common view of technology. He commented:

*I think this is very important that we see the range of views that we teachers have, so that we are able to come to a common understanding of what technology really is.
(17/7/06)*

To further enhance the teachers concepts of technology, several definitions of technology from a range of selected authors were also presented and discussed (see Appendix N). The discussion was based on the identification of common themes seen across all the technology definitions. The aim of this exercise was to help teachers to see the common themes and to establish a common understanding of the meaning of technology. By examining and comparing the range of technology definitions the teachers were given the opportunity to identify any key concepts shared by the range of definitions. Each teacher was asked to identify common themes in the definitions of technology. The following is an excerpt of the conversation between teachers and the PD provider:

Researcher: What are the common themes that you can identify from the definitions presented to you? Can we have one person to pick up one common theme that you can see across the definitions?

Anthony: Technology is application of knowledge.

Researcher: Let's have the next person?

Raymond: Technology is problem-solving.

Ronald: Design process.

Researcher: The next person, please?

Zebedee: Practical activity.

Researcher: What else?

Timmy: Technology is a social process.

Researcher: Is there any more?

Teachers: [No response]

Researcher: Now you can see the common themes that emerged from all or otherwise most of the definitions of technology in the sheet given to you. (17/7/06)

This exercise enabled the teachers to see the common themes that emerged across all the technology definitions. This exercise also contributed to answering the questions teachers had in their mind on how they would ever accomplish a common understanding of technology.

This view was highlighted by Richard as he pointed out:

At first, when I saw teachers with the range of views I was wondering about how can we come to one common understanding of what technology is? Now I can see that the definition of technology has helped us to see technology with a common view and should also be able to guide us to have a common understanding of what technology really is. (17/7/06)

The use of local examples of technological issues and problems was also included in the PowerPoint presentations with handouts given to teachers. The teachers watched a slide show on local situations depicting technological issues and solutions within the Solomon Islands context. The set of slides were presented to portray the power of society in relation to technology which should not be ignored or taken for granted. The focus of this exercise was to enhance teachers' concepts of technology and society, and to enhance teachers' understanding of the interrelationship of technology and society. It also aimed to show teachers that the societal values, beliefs, customs and ethics are very influential on both the success and the failure of any technological outcomes in Solomon Islands. Opportunity was also given to teachers to comment on this presentation, though no comments were made.

The notion of technology as a problem-solving task was further reinforced in session two when teachers viewed a video clip on technological practice, *What Noise Annoys?* In this video clip the teachers viewed technological practice in a real world situation, where solutions to solve noise problems in residential areas in the cities were depicted. This exercise aimed to help teachers understand and consider the authenticity of solving a technological problem in the real world, and to help teachers build a common understanding of what technology is and to develop a more appropriate concept of technology. After viewing the video clip, the teachers were given the opportunity to reflect on what they had seen. Two teachers, Richard and Anthony commented on this video clip, and both teachers pointed out

the different solutions used by various socio-cultural groups in solving the same problem. Richard pointed out what a normal Solomon Islander would do in addressing this noise problem, commenting:

I see this video as quite interesting, as people with a different culture have different ways to solve this kind of problem. If this was in the Solomon Islands, there will be a big argument first before solving the noise problem. I can see that this man in the video is very patient with this noise problem. (18/7/06)

Anthony also had similar views and commented about the different ways various communities addressed the noise problems. He stated:

It's interesting to note that different people have different ways of solving the noise problem. Like some people have to plant trees to stop the noise from coming into their compounds, while others used double walling inside their houses. (18/7/06)

Other presentations to enhance teachers' concepts of technology included the range of reading notes such as Focusing on Technology Education: The effect of concepts on practice (Mather & Jones, 1995), Technology and Technology Education: Views of some Solomon Islands primary teachers and curriculum officers (Sade & Coll, 2003), and The Nature of Technology: A briefing paper prepared for the New Zealand Ministry of Education curriculum project (Compton & Jones, 2004). These reading notes were given to teachers to read and consider in their own time.

Session three on Day One of Workshop One was based on the question, *What is technology education?* The session began with teachers examining their own and their colleagues' perceptions of technology education that had been gathered from interviews in 2005 (refer Chapter Four). The teachers' existing views on technology education were presented on PowerPoint and also on handouts. Interestingly, no one commented on the range of views they had on technology education, although an opportunity for teachers to comment was given. Then the presentation and discussion of the shift of technology curricula in some developed western countries followed. The presentation of curriculum shift showed the trend of moving from an initial craft curricula to craft, design and technology, then to design and technology, and then to technology education and technological literacy curricula. This presentation prompted Richard to comment about the development of technology education in the Solomon Islands over the years. He stated:

To describe the development of our technology curriculum over the last 20 years, it started with crafts and arts, then woodwork, then manual arts, then Industrial Arts, then design & technology, and now we have technology. The development that we are

undertaking is a challenge for us to take to our technology syllabus to a new height. Therefore, the subject we are teaching can only become technology when we decide to teach the new concepts introduced in technology. (17/7/06)

Next was a PowerPoint presentation and discussion of various teaching/learning theory models. A package of reading materials related to these ideas had been distributed to teachers before the first workshop. Their reading of these materials before the workshops helped with the ensuing discussions. This presentation aimed to guide teachers in discussing the ideas presented. After this presentation, two teachers, Timmy and Anthony, made comparisons between their existing teaching approach and the newly introduced teaching/learning approach. Timmy commented:

Looking at the [teaching] approach used in industrial arts, it was only based on technical skills applied to wood, metal and plastics, but the [teaching] approach we are being introduced to is actually broad, which is more appropriate for the technology syllabus. So we are the ones to implement these changes and see these changes come into effect for the benefit of our future. (17/7/06)

Anthony reiterated Timmy's comments. He commented:

I told the curriculum advisor that teaching technical skills alone does not enhance students' ability to think for themselves. From my teaching experiences, the students seemed to pick up the skills quite easily but their problem was they are not able to think for themselves because they have got used to being spoon-fed all the time with the skills teaching approach. (17/7/06)

The presentations in session three were reinforced in session four, by the showing of a video clip on technological practice in the classroom, entitled *Tuakau College*. This video clip was about the senior students at Tuakau College (New Zealand) exporting passionfruit to Japan. It showed how students undertook the technological activity to design a passionfruit storage package and then export the passionfruit from New Zealand to Japan. The clip gave the technology teacher participants the opportunity to view technological practice carried out in a classroom setting. By viewing this clip, the teachers were able to examine some concepts of technology education, various aspects of technological pedagogy, and some technological practices.

Teachers also reflected on technological practice in the classroom setting as was depicted in the video. After viewing, Anthony commented that this video was mostly suitable for New Zealand students because of their richness in facilities, which when compared to the Solomon Islands students highlighted their lack of facilities. He explained:

I think it is easy for those students to do such activities because they have got all the required facilities for their task available to them. In our case in the Solomon Islands, it might be a bit difficult for our students to do such activity because we don't have those kinds of facilities as those students in New Zealand. (17/7/06)

Richard was also fascinated by the video, advanced a similar view and commented that the students were undertaking an advanced task, which he thought was a university level task. He commented:

Now I know that New Zealand students do tasks in real situations. I think these New Zealand students don't need to go to Universities because they have already done the real activities while still in secondary schools. (17/7/06)

However, Timmy pointed out that this video clip had taught him an approach that he could adopt when teaching technology. He commented:

This video has taught me that I can get my students to work in groups and that I don't need to do every thing for them, but to let them to do their own research and be responsible for their own learning as I will only be there to guide them. (17/7/06)

The other form of presentation to enhance the teachers' perceptions of technology education was through reading materials. These were Focusing on Technology Education: The effects on concepts on practice (Mather & Jones, 1995); Technology and technology education: Views of some Solomon Island primary teachers and curriculum development officers (Sade, & Coll, 2003); Nature of technology: Briefing paper prepared for the New Zealand Ministry of Education Curriculum Project (Compton & Jones, 2004); Putting students at the Centre: Developing effective learners in primary technology classroom (Moreland, 2004); and Enhancing student learning in technology through enhancing teacher formative interactions (Moreland, Jones & Chambers, 2001). The reading materials were given to teachers as extra readings to be done in their own time. However, the contents were also used as reference materials for demonstrating effective teaching and learning in session one on Day Two of Workshop One and also in session three in Workshop Two.

In the first session on Day Two of Workshop One, the teachers were given a brief lecture on becoming an effective technology teacher, based on the reading materials referred to above. This session began by highlighting the teachers' existing traditional teaching approaches (refer Chapter Five). Teachers responded to this presentation with mixed reactions. For example, Anthony was a little bit defensive in his response as he commented:

I don't assess the effectiveness of my teaching based on teaching approaches but I assess my effectiveness based on students' exam results and the accomplishment of their tasks. (18/7/06)

Another teacher, Jason, also shared his view on what he thought as effective teaching. He commented:

I think effective teaching should not stop at the students' exam results, but should go beyond that by getting students to continue with what they had learnt at school in society even after leaving school. (18/7/06)

According to the teachers' responses, effective teaching was the outcome of the students' performances either from the exam results or from their performances in whatever they do after leaving school.

Following this brief discussion, a PowerPoint presentation based on planning for effective teaching and learning in technology was presented. The aim was to inform teachers of the key features needed to become effective technology teachers and also to prepare teachers for their own technology lesson planning. The PowerPoint presentation included the following themes: having knowledge of the nature of the subject and its characteristics – technological subject knowledge; setting explicit comprehensible tasks and contexts; embracing all technological learning domains - conceptual, procedural, societal, and technical aspects; employing specific teaching and assessment practices, e.g. authentic, holistic, construct reference; and creating a learning conducive technology classroom environment e.g. managing resources, equipment and technicalities of teaching (Moreland, 2004).

This presentation was then followed by a discussion about learning outcomes. It aimed to focus teachers on learning outcomes when planning a technological unit of work. The concept of learning outcome was not defined as teaching intentions, or management of learning, but as descriptions of what the learner is expected to learn, understand and be able to do in the defined period of learning. The outcome-based model was given to teachers basically to move them from objective-based model and teacher-centred teaching strategies to student-centred learning activities. The discussion enhanced teachers' understanding of the learning outcome-based approach. As Jason and Richard commented:

This is the same thing that Julian tried to explain to us during our previous curriculum workshop but we could not understand because his explanation was not clear enough. Now we understand it better because your explanation was very clear. (Jason)

I think you explain it really well because you are a technology teacher so you know how to link it with the technology curriculum. (Richard)

In undertaking the learning outcome-based lesson planning of technology unit, teachers needed to understand the four learning domains of technology education: conceptual, procedural, societal and technical. This example lesson plan format, shown in Figure 6.2, was adopted from “Learning In Technology Education” (LITE) model (Moreland, Jones & Chambers, 2001). This model was used as the starting point for developing the PD programme as it fitted well with the Solomon Islands context. In contrast, the “Technology Education Assessment in Lower Secondary” (TEALS) model (Compton & Harwood, 2003), though developed at the same time as the LITE model, was not used, as it did not fit as easily with the Solomon Island teaching context. Also the PD facilitator reasoned that the TEALS model would be less comprehensible to Solomon Island teachers. The LITE model was also used as it provided an understandable lesson plan format that supported the Solomon Island teachers with their planning of technology lessons for the second semester of 2006. Listed in the lesson plan format were the teachers’ general learning outcomes and specific learning outcomes written under the four learning domains of conceptual, procedural, technical, and societal. The conceptual learning outcomes focused on the concepts of the design principles, the procedural learning outcomes focused on the procedures under the design process, the technical learning outcomes focused on hands-on skills required for undertaking the task at hand, and the societal learning outcomes focused on people’s views and opinions of the task.

Figure 6.2:
Example lesson plan format

| Planning for learning in Technology Education | | | |
|---|--|--|--|
| Task Definition Design and make a manual coconut scraper that can be used in a small milling factory in the rural area. | | | |
| Overall Dimensions of technology Conceptual –Develop an understanding of a suitable coconut scraper which to serve its purpose. Procedural –Undertake the design process and select appropriate procedures for constructing the coconut scraper. Technical – Develop skills in technical drawings and metal working related to the constructed coconut scraper. Societal – Develop an awareness of people’s preferred kind of coconut scraper for small coconut milling factories. | | | |
| Conceptual Learning Outcomes | Procedural Learning Outcomes | Technical Learning Outcomes | Societal Learning Outcomes |
| Understand that: - strength and balance is important for the coconut scraper - Aesthetics and ergonomics are the key principles of designing the coconut scraper | Understand the: - Designing procedures - The step by step for drawing pictorial and working drawings - Construction procedures - The safety steps in using hand tools and machines - The step by step for constructing the coconut scraper - Evaluation procedures - The step by step in analysing the finished product | Students be able to: - Draw a pictorial view and a working drawing of the coconut scraper - Use drilling machine, grinding machine, welding machine, hand files, and screw drivers, safely | Understand that different people have different preferences to the design of the coconut scraper |

The LITE model assisted teachers on how to plan their task definition, the general learning outcomes under the overall dimensions of technology, and specific learning outcomes under the domains of conceptual, procedural, technical skills and societal knowledge. The task defined was designing and making a coconut scraper to be used in a small milling factory in the rural community. The general learning outcomes included an understanding of a suitable coconut scraper, the use of design process and appropriate construction procedures, the development of skills related to designing and constructing the coconut scraper and understanding people's preferences. The specific learning outcomes were more detailed under the four learning domains. The learning outcomes under conceptual included the understanding of strength and balance and the aesthetics and ergonomics of the scraper designed. The learning outcomes under procedural included the understanding of the design procedures, construction procedures, and evaluation procedures. The learning outcomes under technical included the technical skills and the metal working skills, and the learning outcomes under societal included the understanding of people's preferences in regard to the task defined. When teachers wrote their learning outcomes, they needed to think of learning outcomes under these four learning domains of technology education.

Sessions two and three on Day Two of Workshop One, were given to teachers to plan their technology units for teaching in second semester of 2006. Teachers were given blank lesson plan formats to use for planning their technology lessons. To help speed up the lesson planning process, the teachers were asked to base their defined tasks mainly on the original unit tasks that they had already planned for semester two of 2006. In this case, most teachers used their past unit tasks while only one teacher, Timmy, decided to define a new unit task. All teachers used the blank lesson plan format to plan the general learning outcomes of their defined tasks and the specific learning outcomes under the four learning domains. The details of the teachers' lesson plans are discussed in Chapter Seven.

While teachers were undertaking their lesson planning guided by the example lesson plan format, two other teachers suggested that it would be good to use a lesson planning format that links with the new technology syllabus developed by the Curriculum Development Center (CDC). For example, Ronald suggested the use of another format as he commented:

It would be good if we could use the new technology syllabus format as the CDC would like us to implement the new syllabus, rather than using different lesson format especially the one which we are using in this workshop, and link it with the learning process that we have learnt during this workshop. (18/7/06)

This view was also advocated by Gilson who said:

It would be good if the lesson planning approach of this workshop be linked to the proposed CDC approach and looked at similarity, etc. (18/7/06)

After the teachers requested a lesson plan format that linked with the new technology curriculum, another example lesson plan format was drawn up in session three, basically to satisfy the teachers. The second format (see Figure 6.3: Programme of work format) was drawn up for teachers as an additional lesson plan format for teachers to use for planning their work sequences when undertaking their defined tasks. This format was based on the design and technology approach which the teachers were more familiar with. These teachers were also teaching in the Senior Forms and had a lot of experience with the design process approach teaching. These teachers had already used the design approach as a teaching approach with their Senior Forms (Forms Five and Six), however, not as it appeared in this format.

Figure 6.3
Programme of work format

| Semester two Unit Planner - 2006 | | |
|----------------------------------|--|--|
| Weeks | Design Process Phases | Activities |
| Week 1 | Investigation, Designing and Devising ↓ | Identify context – Real life situation, News papers, Community based information etc |
| Week 2 | | Brain storm – to identify & select the technological task |
| Week 3 | | Develop design brief or task definition |
| Week 4 | | Identify the appropriate strands (learning areas) related to the task defined |
| Week 5 | | Consider the stake holders involved and include them in the investigation process |
| Week 6 | | List specifications required for constructing the task |
| Week 7 | Construction Phase ↓ | Devising initial ideas |
| Week 8 | | Designing the initial concepts – 2D/3D – Drawing skills |
| Week 9 | | Technical drawing skills – Orthographic & Pictorial - Isometric/oblique |
| Week 10 | | More investigation and research – Technological & societal knowledge/concepts |
| Week 11 | | Interviews/surveys – develop questionnaires |
| Week 12 | Evaluation and marketing promotion ↓ | Recorded/researched notes – Communication skills |
| Week 13 | | Identify relevant technological / scientific concepts related to the product |
| Week 14 | | Note taking – uses of the product, required design & scientific principles |
| Week 15 | | Research and note taking - |
| Week 16 | | Reassess/evaluate the designing and devising process |
| Week 17 | | Self/peer analysis |
| Week 18 | | Teacher/client analysis |
| Week 19 | | Students construct their designed products |
| Week 20 | | Skills to be taught/learnt |
| Week 21 | | Skills to be taught/learnt |
| Week 22 | | Skills to be taught/learnt |
| Week 23 | | Skills to be taught/learnt |
| Week 24 | | Skills to be taught/learnt |
| Week 25 | | Evaluation of the project |
| Week 26 | | Final presentation |
| Week 27 | | Promotion and Marketing |
| Week 28 | | |
| Week 29 | | |
| Week 30 | | |
| Week 31 | | |
| Week 32 | | Unit Test |
| Week 33 | | Revision |
| Week 34 | | |
| Week 35 | | Examinations |
| Week 36 | | Examinations |
| Week 37 | | |
| Week 38 | | Report Writing |

This lesson plan sequence format (Figure 6.3) was based on the design process approach and was adopted from the Curriculum Development Center (CDC) of the Ministry of Education in Solomon Islands. This format outlined week one to week twenty with three design phases (design, construction and evaluation) and activities under each of the phases. The investigation, designing and devising phase was planned to be covered in six weeks. The construction phase was planned to be covered in four weeks and the evaluation and marketing phase to be covered in three weeks. Under the design phase, the students' activities included identifying the context and defining the task, developing design briefs and specifications, and drawings of the task defined. No student activities were listed under the construction and evaluation phase but the subheadings given were guides for the teachers to understand and follow. The construction phase was about the construction of the task designed and learning about the procedural knowledge and skills associated with the design task, and the evaluation phase was about students' self assessment and marketing of the task. This format helped the teachers to organise their task sequences into weeks, and under the themes of the design process.

Both lesson plan formats were used by teachers to plan their technology lesson to teach in semester two of 2006. The first format was used for defining the task and the general and specific learning outcomes, and the second format was used for outlining the lesson sequences throughout semester two. During these two sessions, the PD provider supported individual teachers as they were planning their lessons. The details of each teacher's lesson plans are discussed in Chapter Seven.

Workshop One was then wrapped up in session four of Day Two with an evaluation exercise undertaken by the teachers. The details of the teachers' evaluation of the first workshop are analysed next.

Teachers' reflection through evaluation of Workshop One

At the end of Workshop One on Day Two, teachers were given the opportunity to reflect back on the workshop through an evaluation exercise. Shown in Table 6.3: are the teachers' responses to the first two questions from the evaluation exercise. First is the teachers' response to the overall content in regard to the balance between theory, activities, and

discussions etc. The second question was based on the length of time in regards to each session as well as the overall time.

Table 6.3
Evaluation of the overall content and length of time of Workshop One

| Issue | Number of responses | | |
|-----------------|---------------------|------------------|---------------|
| Overall Content | Poor = 0 | Satisfactory = 2 | Excellent = 6 |
| Length of Time | too short = 4 | adequate = 4 | too long = 0 |

Out of the eight teacher participants, six teachers indicated that the overall content of Workshop One was excellent, while the other two teachers indicated satisfactory and no one indicated that it was poor. Five of the six teachers who had indicated excellent commented that their understanding of technology and technology education had been enhanced by the concepts learnt in the workshop. Zebedee commented:

The concept taught in this workshop on day one really gives me a clearer picture when looking at both the technological concepts and technology education. (18/7/06)

Raymond shared similar thoughts as he commented:

Thank you very much for your time, I've learnt a lot and this has really expanded my knowledge on the technology education topics. (18/7/06)

Three other teachers, Richard, Gilson and Jason, stated that the concepts learnt in workshop one did prepare them as technology education teachers and for teaching the technology curriculum. Richard stated:

I really gained from this workshop because it will be very helpful for the implementation of the newly reviewed curriculum. (18/7/06)

Gilson made similar comments as he said:

I just want to say here that such workshops are a credit or a bonus to us, as we are in the process of implementing a new syllabus. (18/7/06)

Jason affirmed his colleagues' views, commenting:

This workshop gives me great insight to my teaching profession as a technology teacher. (18/7/06)

The two teachers, Ronald and Anthony who indicated that the workshop was just satisfactory made their comments in reference to the unexplained technology vocabulary and the

workshop timing. Ronald pointed out that he had difficulties in understanding the new technology vocabulary used by the PD provider. He commented;

You [PD provider] should elaborate on new terms and phrases you have used. (18/7/06)

And Anthony made his comment in reference to the short time given to Workshop One. He explained:

It can be excellent, but due to a short time, we just rush up with our explanation of things, so we don't have enough time to really express ourselves clearly and slowly. (18/7/06)

The other teachers who rated the workshop as excellent also commented on the length of time used. The length of time given to the teachers throughout the workshop was considered by four teachers as too short, four teachers as adequate and none indicated the time as being too long. The majority were in favour of the content, with sharing time never thought by any teacher participant to be too long and tiring. Instead, half of the teachers thought it was too short, while the other half thought it was just enough. The teachers who thought the time was too short pointed out that more time was needed for discussion and sharing of views in these sessions. Anthony stated:

The workshop is excellent, but due to a short time, we just rush up with our explanation of things, so we don't have enough time to really express ourselves clearly and slowly. (18/7/06)

Jason also supported the idea of having more time for discussion and sharing in these sessions, commenting:

I think more time is needed for group discussion and reporting after every session, so that we feel that we do really participated in the programme. (18/7/06)

Likewise, Raymond added that timing for planning lessons in sessions two and three should be extended to allow for more practice. He said:

I would like to see that more time is given to session two and three on day two, because I need more practice so that I can be more confident in writing lesson plans. (18/7/06)

Teachers' reflections on the relevance of the workshop sessions

A majority of teachers indicated that all the workshop sessions of Days One and Two were relevant to them as technology education teachers. The teachers' reflections on the relevance of Day One workshop sessions are shown in Table 6:4a: Relevance evaluation of Day One sessions of Workshop One and the relevance of Day Two workshop sessions are shown in

Table 6.4b: Relevance evaluation of Day Two sessions of Workshop One. The numbers which the teachers indicated on the continuum scale indicated their views on the relevance of the sessions in helping them gain better understanding of the nature of technology and technology education and planning for effective technology teaching.

Table 6.4a

Relevance evaluation of Day One sessions of Workshop One

| Workshop One – Day One | Not Relevant ←————→ Relevant | | | | |
|---|------------------------------|---|---|---|---|
| | 1 | 2 | 3 | 4 | 5 |
| Session 1 – Technological concepts/nature | | | 2 | | 6 |
| Session 2 – Technological practice - Video | | | 2 | | 6 |
| Session 3 – Technology education trends | | | 2 | | 6 |
| Session 4 – Technological practice in the Classroom – Video | | | | | 8 |

Table 6:4a shows that out of eight teachers, six thought that sessions one, two and three were relevant. Two teachers thought the sessions were somewhat relevant. All eight teachers thought session four was relevant, all indicating five on the continuum relevance scale.

Table 6.4b

Relevance evaluation of Day Two sessions of Workshop One

| Workshop One- Day Two | Not Relevant ←————→ Relevant | | | | |
|--|------------------------------|---|---|---|---|
| | 1 | 2 | 3 | 4 | 5 |
| Session 1 – Becoming an effective technology teacher | | | 1 | | 7 |
| Sessions 2 & 3 – Hands-on Planning activity | 1 | | 1 | | 6 |
| Session 4 – Wrap up and Evaluation | | | | | 7 |

According to the teachers’ evaluation of the relevance of the sessions on Day Two of Workshop One, shown in Table 6.4b, a majority of seven teachers thought that session one was very relevant and one teacher indicated that it was somewhat relevant. Six teachers indicated that sessions two and three were relevant, one indicated somewhat relevant and one not relevant. Session four which was used for closing remarks and completing the evaluation sheet was thought by seven teachers as relevant, while one teacher left it blank.

Teachers’ reflections on the sessions they benefited most from in Workshop One

Three teachers viewed the Day One sessions of Workshop One as sessions that they benefited from the most. Jason, Zebedee, and Timmy made comments on how they benefited from these sessions. For example, Jason picked session one. He stated:

The content on session one of day one had broadened my view on what technology is. (18/7/06)

Similarly, Timmy stated that he gained from sessions on Day One and specifically picked on session three as the session he mostly gained from. He commented:

Session three of day one helped me to understand the socio-cultural view of learning. I now fully understand this theory and it is a good concept to use in classroom teaching which I think can work in the Solomon Islands. I also believe that it will help the students to develop self reliance. (18/7/06)

Unlike the two previous teachers, Zebedee stated that he gained most from all sessions on Day One in Workshop One. These sessions helped him better understand the nature of technology. He said:

The sessions of day one has enlightened me on technological concepts and actually gives me a clear view on the nature of this subject. (18/7/06)

Day Two sessions of Workshop One were viewed as the most beneficial sessions by a majority of seven teachers. The teachers talked about these sessions as mostly helpful because they were based on the activities associated with classrooms practices. Gilson commented:

I gained the most from session one, two and three on day two because these were the sessions focused more on the actual activities that I am involved in – and that is teaching and learning. (18/7/06)

This similar view was expressed by Zebedee, as he said:

I gained most from session two and three on day two which was on planning classroom practices, as I'm a teacher, I always need to plan my classroom tasks. (18/7/06)

Ronald could not agree more, and pointed out that his actual involvement in discussing and writing of his lesson plans as a teacher, made sessions two and three more beneficial to him. He said:

Session two and three on day two of workshop one were the session I gained the most from because it deals with the importance of teaching and learning aspects and we actually write down and discuss the issues that we talked about concerning teaching and learning. (18/7/06)

Likewise, the planning activities undertaken by teachers in sessions two and three of Day Two were well understood by Anthony who commented:

Session two and three on day two of workshop one was very helpful because the planning activities were explained very clearly. (18/7/06)

The experiences teachers gained from these two sessions in Workshop One really impacted on their existing views of technology classroom practices. However, Jason suggested that more time and examples would reinforce the benefits of sessions two and three. He commented:

Session two and three of day two gave me insights of what I should do apart from the current practice. However, the time was too short, and more examples were needed for further clarification. (18/7/06)

He further added that session one did give him a good reminder though on becoming an effective teacher. He said:

Session one of day two reminded me that the effectiveness of teaching and learning technology depends on my knowledge and attitude towards the subject. (18/7/06)

This view was reiterated by Raymond, as he pointed out that session one of Day Two did enlighten his thinking on becoming an effective technology teacher. He explained:

Session one of Day Two has enlightened me on becoming an effective technology teacher, because it clearly explains and directs me to know about students learning and directs me as a teacher to stay in focus in terms of understanding what and how students learn in the classroom. (18/7/06)

The sessions that interested most teachers were the sessions of Day Two of Workshop One which focused mostly on becoming an effective teacher and the hands-on activities in planning classroom lessons.

Researcher's evaluation of Workshop One

All three workshops were pre-planned, and Workshop One was intensively undertaken in two days. The teachers were very impressed with Workshop One. The content of Days One and Two were appreciated by almost all the teachers, in terms of having a balance between theory and hands-on experiences. The theories presented on various definitions of technology and technology education and the concepts of technological practice from the videos shown on Day One were discussed by teachers during the sessions. The comparisons teachers made during the discussions helped them to see the differences between their own views and the various definitions of technology and technology education. The videos also contributed to the enlightenment of their views. Although the two videos were on technological practice in a foreign context, the technological concepts depicted in both videos were grasped by most teachers.

In Day Two of Workshop One, the teachers were given the opportunity to plan their own lessons for teaching in the second semester of 2006. Out of the four sessions, the first session was used as a lead up session to get teachers to prepare for the two hands-on activity sessions on lesson planning. The lesson plan format and how it should be used by teachers to plan their own technology lesson was presented in that session. Later on, in sessions two and three the teachers got to actually use it to plan their own technology lessons. However, the lesson planning was an area that teachers found difficult. Most teachers did not manage to complete their lesson planning by the end of the first workshop. The teachers were concerned, and would have liked to have had more time for lesson planning. The delivery of the content of Workshop One was intensive but the two days and the time given seemed to be too short. In considering the teachers' concerns from Workshop One, I decided to continue assisting individual teachers with their lesson planning during my school visits, simply because it was urgent and I could not put it off until the next workshop. The other concern that was also raised by teachers at the end of Workshop One was that the length of time given for discussion and sharing of ideas was not long enough. Therefore, I made adjustments to the second workshop. To provide for more discussion and sharing time in Workshop Two, the original idea of having only one session for teacher sharing was extended to include another session. The details of Workshop Two are discussed next.

6.3.2 Workshop Two

Workshop Two was held after six weeks of classroom practice as part of the ongoing PD programme. The teachers' second workshop was undertaken in one day with four sessions (see Table 6.5: Overview of the sessions of Workshop Two). Each session lasted for an hour and half, as in Workshop One.

Table 6.5
Overview of the sessions of Workshop Two

| Workshop Two - One Day | | | |
|---|--|--|------------------|
| Session 1 | Session 2 | Session 3 | Session 4 |
| Teacher reflection and sharing of the past six weeks of classroom experiences | Teacher reflection and sharing continued | Enhancing teachers' concepts of developing effective learners and assessment for effective technology learning | Wrap up session |

As shown in Table 6.5, the first two sessions were used by teachers to reflect on their first six weeks of classroom practice and to share their experiences with colleagues. In session three, a presentation was undertaken focused on enhancing teachers' concepts of developing effective learners and assessment for effective technology learning. The workshop was wrapped up with an evaluation of Workshop Two in session four.

Content outline of teacher activities of Workshop Two

The first two sessions of Workshop Two were used for teacher reflection and the sharing of teaching experiences with colleagues. These two sessions were chaired by the PD provider, and all seven teachers took the opportunity to reflect on and share the first six weeks of classroom teaching. Teachers shared and discussed their teaching successes and the difficulties that they had encountered in the first phase of the trial period. This exercise aimed to provide teachers with the opportunity to listen to their colleagues and to help them draw comparisons with their own classroom experiences, to ascertain their knowledge and to help narrow any practice gaps. At the end of each teacher's reflections and presentation, teachers were given the opportunity to question each other. These reflection sessions were appreciated by the teachers and were also viewed as beneficial sharing time with colleagues. As Richard commented:

This kind of workshop is good, as it gives us time to do what we have learnt during the workshops in our classrooms, and then return to another workshop to share it with you and the other colleagues. (27/8/06)

Several themes emerged from the teachers' reflections as they shared their classroom experiences with colleagues. These included reflections about the new teaching approach, students' activities, and challenging circumstances. The details are discussed next.

In the reflection sessions, Raymond commented on the new teaching approach he employed when teaching his technology lesson. He compared this new teaching approach with his old style of teaching. He pointed out that the new teaching approach saved a lot of teaching time, which made teaching a lot easier. Consequently, students' work was also able to be completed on time. He commented:

My view on this teaching approach is that it is easy to follow, so it is quite nice. And it is also better than the old approach in a sense that we are able to complete our projects/tasks on time. By this I mean, with the old approach, I kind of taught the theory bits first before I actually started the design process or approach. But with this new approach the theory lessons are integrated into the design approach, which does not

take up much of the class and teaching time, which contributes significantly to saving a lot of class time. This approach worked well for me as I when I got to a certain stage of the project I then slotted in a theory lesson which was relevant to the timing of the students to be able to get on with the next stage of their practical project. So with this approach, it keeps the progressive work flowing and I found that it is very easy to follow, and because this approach saves a lot of time, I also think that the tasks the students are working on will also be completed on time. (27/8/06)

Raymond also highlighted the frustration he encountered as he trialled his technology task, related to the slowness of his administrators in getting the materials to his technology class on time. The delay affected whether the students' completed on time. He commented:

The only negative factor that actually affects us at the moment is that we could not get the required materials for the students' tasks simply because our administrators would not purchase them for us. Normally in this kind of situation, the students would actually start with their design folios until the materials were purchased. This has certainly affected the completion of the project on time. So from experience with the old teaching approach, including those limitations, it is very difficult to get the students tasks completed or done on time. With the new teaching approach, provided that the required materials for the students' task are available and provided on time, I think it is a nice approach to follow. (27/8/06)

Another teacher, Ronald, had another explanation related to the new teaching approach. In his reflection, he drew a diagram (as shown below in Figure 6.6: Ronald's view of the new teaching approach) to explain his view on the new teaching approach that he had learnt from the first workshop.

Figure 6.4
Ronald's view of the new teaching approach

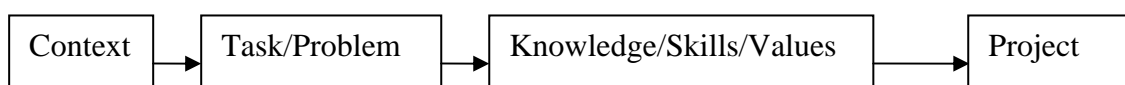

After Ronald drew this diagram on the blackboard, he then explained it to the teachers. The following excerpt is the explanation of his diagram:

With the new concepts, we started by identifying a context and the problem to be addressed, then we looked at the knowledge and skills to be taught, and then we looked at values of the concepts which reflect the society or the community. So in other words, if we need to make a project for example, a table, or house, or a car, we need to first of all consider the context in which the project is to be undertaken before we can actually start with the project by using the strategy, or the format of problem solving, such as identifying of the need, writing of the design brief, and the identification of the required knowledge and skills to be taught. (27/8/06)

Ronald's diagram and explanation highlighted the process he undertook for teaching and learning technology education. His approach to teaching technology was reflective of the design problem-solving approach with a context base.

Zebedee pointed out that the new teaching approach was adopting the context concept along with the design problem-solving approach teaching strategy. He stated that his class's technology task was based on a school context because they were making a seat to be used in the school science laboratory. He found that the new teaching approach was easy to follow, as the decision to use metal for the frame of the stool with a wooden top helped him to identify the content topics including the skills which were to be taught. He stated:

We have picked a school context in which the students' task is based. The problem that we would like to solve, or the need to be addressed, is that our new school science laboratory does not have any seats. So when the problem is given to the students, with my guidance, a stool was then decided as the most appropriate form of seat to be used in the science laboratory. As we further discussed the idea on what kind of materials to be used, metal was more favoured for the frame with a wooden top because it is much stronger and more durable than a wooden stool. So my content topics, along with the skills to be taught, were picked from the metal fabrication and woodwork notes/text books. (27/8/06)

Zebedee's reflection highlighted the context-based approach with a problem-solving focus in teaching technology education.

Zebedee's reflection was followed by a short discussion, as the teachers asked him for further information and made comments. The following is the excerpt of the teachers and the PD provider's discussion.

Anthony: How do your students managed to make the number of stools required for the science laboratory?

Zebedee: Well, each student was given three stools to make to make up the required number. After the students completed their first stool, which I assessed, they will continue with the next two.

Gilson: How much does this project cost you?

Zebedee: It costs us about \$3,000.00 to make the 40 stools for the science laboratory.

Raymond: I think your school is very supportive to you because your class is making something for the school.

PD Provider: So it's a good idea to use the school context when you decide on your technology task so that you can get financial support from the school administration.

The discussion provided teachers with the opportunity to interact with each other through questioning and sharing of classroom experiences.

Anthony also talked about the new teaching approach that he undertook in teaching his technology class. He talked about it as a student-centred based approach. He commented that both the design and construction of the task were undertaken by the students:

The teaching approach that I've taken is basically focused on a student-centred approach. So the task that we are doing in class is actually done by the students themselves. I've identified the task and the students have actually designed it themselves and constructed it using their existing knowledge and skills. My role is just basically to guide them as they were designing their projects and I will continue this approach during the construction stage. In my class, I kind of left the students to work on their own and let the students teach each other if they have any problems. I can only assist them if they want my help. (27/8/06)

Anthony's comments indicated that he too had a grasp of the new teaching approach and highlighted the student-centred approach used in teaching technology education.

Another thing that Anthony also highlighted in his reflection was the new emerging learning outcomes. He realised while teaching that some new procedural learning outcomes he had not previously included in his lesson plan now needed to be included in the teaching process. He said:

Another thing that I also discovered is that the procedural learning outcomes still need to be broken down again to take into account the minor processes which I need to teach. This idea came to my mind when I realised that there are other learning outcomes that I need to teach which I did not think of the first time. (27/8/06)

After Anthony presented his classroom experiences, other teachers asked questions and commented on the assessment of the design process approach. The following is the excerpt of the conversation between the teachers and the PD provider:

Ronald: When we give students designed their own projects and they need to come up with their own ideas, how do we assess those kinds of activities?

Anthony: I think it doesn't matter how the outcome turns out to be with their first task. What matters is that they will get better and better as they continue to do this kind of task.

Timmy: What we consider in assessment is the final outcome and that is what they had come up with.

PD Provider: We will come to that when we look at assessment in the next session. I hope some of the questions you might have on assessment will be addressed.

The discussion provided teachers and the PD provider with the opportunity to talk about issues related to assessment in technology.

In Timmy's reflection on his six weeks of classroom practice, he talked about his Form Two class and the task that they undertook. He explained that the unpackaged soaps that were manufactured by the Form One students at his school in semester one had given him the opportunity to use his Form Two technology class to design and develop a package to be used for these soaps. In this task, Timmy believed that his students were following the problem-solving design process approach. He commented:

Our Form One Science class has made soap but it did not have a package. So I decided this task of designing the soap package would be done by my Form Two Technology classes. So I developed activities for the students like asking them to explore the content of the existing soaps in the shops or at home. So our students were working within these contexts. I then came up with a design folio template for the students to use as they worked through their project. From this design folio the students then developed their design brief and a list of specifications. With this design folio template the students started with a design problem, then they had to write the specific problem they were working with or trying to solve. (27/8/06)

It is apparent in Timmy's comment that he also undertook the design approach with a problem-solving focus when teaching his technology lesson.

Gilson reflected on the difficulties he had encountered in his six weeks of teaching. He pointed out that he was not keeping up with the time frame allocated for the first classroom practice session due to circumstances beyond his control. He explained:

I'm going to briefly outline some of my shortfalls or failures in my trialling of the units in classroom practice, because of certain situations and circumstances or difficulties that our school was facing or encountering at that particular time frame. Here are the main ones:

- *The number of students in my class is too many - about 80 plus for technology classes.*
- *The reluctance and slowness of our school administration to provide us with the required materials in order to get the task done in the allocated time frame is another factor.*
- *The uncertainty of students not sure if the materials would be purchased resulted in them not bothering to start their tasks or even to start designing the task and so forth, although they already knew what their project was. (27/8/06)*

The barriers to successful technology teaching identified by Gilson included the large number of students, lack of required materials, and students' reluctance to begin designing because of

uncertainty with material supply. Although Gilson encountered those difficulties, he still encouraged his class to get on with some other work related to their task. He commented:

But while waiting we substituted those times with practicing technology graphics, which went inline with the task being identified. This led on to problem solving of the technological situation that was answerable to the design brief outline. (27/8/06)

In session three, teachers learned about the concepts of assessment for effective technology learning. Two PowerPoint presentations were undertaken in session three. The first presentation focused on enhancing students' learning in technology education, and the second presentation focused on assessment to enhance students' progression in learning. The first presentation covered sub-topics such as developing effective learners, enhancing effective learning in technology, considering a holistic task approach, and guiding students to work iteratively. The second presentation covered sub-topics such as shifts in assessment, formative assessment, progression, categories of progression in technology, and summative assessment. Both presentations were based on Moreland's (2004) work. The main focus for session three was to inform teachers about the nature and the role of different types of assessment. The presentation also focused on providing teachers with an opportunity to enhance their understanding of diagnostic, formative and summative assessment.

Workshop Two was then wrapped up by an evaluation exercise undertaken by the teachers in session four. The details of the teachers' evaluation of the second workshop are discussed next.

Teacher reflection through evaluation of Workshop Two

The teachers were given another opportunity at the end of Workshop Two in session four to reflect back on the workshop activities. They were asked to indicate what they thought about the overall content of the workshop and the length of time (day and sessions). The results of the teachers' evaluation of the overall content and the length of time are shown in Table 6.6.

Table 6.6
Evaluation of the overall content and sharing time of Workshop Two

| Issue | Number of responses | | |
|-----------------|----------------------------|------------------|---------------|
| Overall Content | Poor = 0 | Satisfactory = 1 | Excellent = 7 |
| Length of Time | too short = 1 | adequate = 7 | too long = 0 |

As shown in Table 6.6, seven teachers thought the overall content in regard to the theory presentation and discussion etc., was excellent, while one teacher indicated satisfactory and no one thought it was poor.

Only two of the teachers, Timmy and Anthony, commented on why they thought Workshop Two was excellent. Timmy stated that the workshop had enlightened his views on the subject and revealed his weakness. He said:

The workshop gives me more insights, ideas and I've also seen my weakness which I will improve on. (27/8/06)

Anthony, who really appreciated the workshop, felt that it would be good if the curriculum staff responsible for technology education could be part of this workshop. He commented:

This is a very useful workshop and only if our boss from the curriculum centre is here, he would have seen this vision as we have seen it, as he is in a better position to support us implement the new technology syllabus the way it is presented to us in these workshops. (27/8/06)

However, Anthony, who indicated that Workshop Two was just satisfactory, also commented in favour of the equal distribution of discussion. He said:

Discussion is quite well distributed between the chairman and the teachers as well as between the teachers. (27/8/06)

A majority of seven teachers were satisfied with the timing and thought the length of time in Workshop Two was adequate, one teacher thought the timing was too short, and no one thought it was too long. Raymond, Richard and Zebedee, who indicated that the timing of the workshop was just enough, were satisfied with the workshop content in general, and praised the discussion and sharing aspects of the workshop. For example, Raymond pointed out that he was more satisfied with the time given for discussion. He said:

I'm satisfied because we have more discussion this time around.

Richard shared this view as he talked about how the time given to every teacher participant to share their classroom experiences with colleagues was long enough. He commented:

Everyone has been given a fair chance this time to express themselves. (27/8/06)

Zebedee also talked about the discussion aspect in Workshop Two as being well distributed between all teacher participants and the PD provider. He said:

Discussion is quite well distributed between the chairman [PD provider] and the teachers as well as between the teachers. (27/8/06)

These three teachers shared the same view on discussion as a satisfactory aspect of Workshop Two.

Teachers also evaluated the relevance of each session (as shown in Table 6.7: Teachers' evaluation on the relevance of Workshop Two sessions). The relevance scale was on the same continuum criteria where the number range from one to five was again adopted with one on the continuum representing not relevant while five represented relevant. As in the evaluation of the relevance of Workshop One, the number which the teacher indicated on the continuum scale indicated were their view on the relevance of the sessions in terms of helping them gain better understanding of becoming an effective technology education teacher and helping students to become effective learners.

Table 6.7:
Teachers' evaluation on the relevance of Workshop Two sessions

| Workshop Two | Not Relevant ←————→ Relevant | | | | |
|--|------------------------------|---|---|---|---|
| | 1 | 2 | 3 | 4 | 5 |
| Sessions 1 & 2– Reflective Summary | | | 1 | | 7 |
| Session 3 –Assessment for Effective Learning | | | | | 8 |
| Session 4 –Evaluation & Wrap up Briefing | | | 1 | | 7 |

In assessing the relevance of the sessions of Workshop Two, a majority of teachers indicated that all the workshop sessions were relevant to them as technology education teachers. Seven teachers indicated five for relevant, one teacher indicated three for somewhat relevant for sessions one and two. None of the teachers thought that the two sessions were not relevant. A majority of teachers thought the reflection and sharing time in session one was relevant to them as technology teachers. In evaluating session three on assessment for effective learning, all eight teachers thought session three was relevant and indicated five on the continuum scale. Finally, seven teachers thought the evaluation session was relevant and indicated five, while only one teacher thought the evaluation session was somewhat relevant indicating three on the continuum scale.

Teachers' reflections on the sessions they most benefited from in Workshop Two

This section analyses the teachers' reflections on the sessions which they benefited from the most. Table 6.8 shows the four sessions and the number of teachers who selected the sessions. Sessions one and two related to teachers' reflection on their six weeks of classroom practice, session three was on assessment for effective learning and session four was on evaluation and wrap up briefing.

Table 6.8
Sessions of Workshop Two that teachers gained most from

| Workshop Two | Sessions 1& 2 | Session 3 | Session 4 | All Sessions |
|---------------------|--------------------------|------------------|------------------|---------------------|
| Day One | 2 | 4 | - | 2 |

In selecting the sessions which teachers gained the most from, two teachers selected sessions one and two, four teachers selected session three and no one selected session four. Two teachers thought that they gained something from all sessions.

Jason, who selected sessions one and two as the two sessions he had benefited most from, stated that the sharing time was enlightening and informative. The sharing time helped him clarify his doubts and enhance his understanding of the subject. He stated that:

The discussion in session one and two has cleared up some of my doubts and through sharing ideas with other colleagues it really helped me to understand things much clearer. (27/8/06)

Raymond also said that the first two sessions of Workshop Two were beneficial because he learnt a lot from the teachers' discussions and the sharing of ideas from their six weeks of teaching experience. He commented:

I found the first two sessions very helpful because it involved a lot of discussion and sharing of what teachers have been doing in their classrooms with their students. (27/8/06)

The four teachers who selected session three as the session they benefited the most from also stated their views. Timmy stated that in session three he learnt about writing assessment criteria for the task which was to be undertaken by his students. He stated:

Well now I can write down the assessment criteria for my students' project after session three of the second workshop. (27/8/06)

Anthony, pointed out that session three helped him understand how to assess the learning outcomes. He said:

I like session three because it really spells out clearly the weights of each Learning Outcome. (27/8/06)

Zebedee stated that session three helped him understand the three types of assessment used for assessing students. He commented:

Session three helped me to have a clear picture of the real difference between those three types of assessments, diagnostic assessment, formative assessment, and summative assessment and also how to apply them to the students. (27/8/06)

The fourth teacher, Gilson, added that session three also helped him to understand how to properly assess students to help them with their learning. He said:

In session three I had learnt that assessment is also about how we as teachers could assist our students to move on in their learning. (27/8/06)

Two other teachers did not select any specific session from Workshop Two and instead viewed all sessions as useful and beneficial. Richard favoured all the sessions because he thought that all the sessions were related to the new teaching concepts that all the teachers were trialling during their first classroom practice session. He said:

All sessions are relevant as they all are related or are part of the new approach which are implemented by at least some or otherwise all of us. (27/8/06)

Ronald also shared this view and commented about the usefulness of all sessions for him as a technology teacher and his students. He said:

All sessions were very important and helpful for me as a teacher and for my students learning in technology. (27/8/06)

The sessions teachers talked about as sessions they gained most from were varied but positive.

Researcher's evaluation of Workshop Two

Workshop Two was undertaken in one day with four sessions. The first two sessions were used for teacher reflection, discussion and sharing of ideas. This reflection session was requested by teachers at the end of Workshop One. Teachers really appreciated the two sessions they had in Workshop Two for sharing their teaching experiences over the previous six weeks. With more time given in Workshop Two for sharing and discussion, the teachers

were more satisfied with the discussion time in Workshop Two than in Workshop One. I noticed that teachers were very eager to share their teaching experiences with colleagues and myself. The teachers indicated that they really appreciated the length of time given to teachers to share their teaching experiences with colleagues and learn from each other. Some things that teachers indicated as useful during the sharing time, such as the desire for continual school visitation, were already part of the PD programme. Other things teachers requested could not be undertaken as they were not part of the PD programme. These were things such as getting the Curriculum Officer to be part of this PD programme, and getting the school administrators to provide the teachers with financial support.

The session on enhancing students learning and teachers' concepts on assessment for effective technology learning in Workshop Two was also appreciated by the teachers. This session enlightened the teachers' understanding on ways to undertake effective approaches in teaching and assessment that would help students become more effective learners in technology education. This session also enlightened the teachers' understanding of diagnostic, formative and summative assessment.

From this evaluation little adjustment was required for Workshop Three. Therefore Workshop Three sessions remained set except for an allowance of flexibility in the reflection time in session three. Workshop Three is discussed next.

6.3.3 Workshop Three

The teachers' third workshop was an overview time for teachers to reflect on the entire PD programme and was undertaken in one day with only two sessions (see Table 6.9: Overview of sessions of Workshop Three). The two sessions were used mainly for teacher reflection and a wrap up of the whole PD programme.

Table 6.9
Overview of sessions of Workshop Three

| Workshop Three – One Day | | |
|---|--|--|
| Session 1 | Session 2 | Lunch |
| Teacher reflection on the whole PD programme including classroom practice | -Teacher reflection continued from session 1 - Teacher discussion on possible suggestions for helping other teachers cope with the new curriculum and the new teaching approach to technology education - Evaluation of the whole PD programme | Official closing after lunch with acknowledgements made. |

Teacher reflection took up almost all the two sessions of the one day workshop in Workshop Three. The first part of the second session was also given to teachers for reflection because they needed more time. The second part of session two was for teachers to suggest ideas for how their colleagues could best be informed of the new technology curriculum and new teaching approaches for technology education. An evaluation of the whole PD programme was undertaken towards the end of session two. The workshop officially closed after lunch and acknowledgments were made. The details of these two sessions are discussed next.

Content outline of teacher activities of Workshop Three

Session one and part of session two of Workshop Three was used for teachers to reflect on the previous six weeks of their classroom experience in the PD programme. The teachers were also given the opportunity to ask each other questions after each teacher presented their classroom experiences. Interestingly, most comments made by teachers in Workshop Three were very similar to the comments made during the reflection sessions in Workshop Two. Only two teachers' presentations were followed by questioning and discussion. The teachers' reflections on classroom experiences in both workshops were focused on their experience with the use of the new teaching approach. For example, Zebedee again made reference to the new teaching approach in Workshop Three. He pointed out that the nature of this teaching approach enabled him to provide many opportunities for students to get involved in discussion and active thinking. He commented:

I found that the teaching approach which we were undertaking was easy to follow and was very helpful for me in my teaching. With this approach to teaching, the students

have done a lot of discussion and thinking as they talked about the different range of solutions required to solve the problem at hand. This kind of exercise gives the students a lot of opportunities for discussion. (26/10/06)

In his remarks, Richard pointed out that the new teaching approach was very interesting and motivating to teachers and students alike. He highlighted that students' participation when they were undertaking the task was the best part of the new teaching process. He commented:

From my experience of this new teaching approach I found it very interesting and very effective. I found it very exciting to go through the whole design process with my students. The best part of it is that students were involved in undertaking the task and I'm only there to give them the assistance whenever they need it. (26/10/06)

Timmy also reiterated this view as he added that the design process approach motivated his students to take control of their learning, as they ventured into new areas of knowledge. He further stated that this teaching approach enabled his students to think and do things themselves and he was a guide to their learning. He commented:

The main thing that I would like my students to understand and learn about the design process is how to identify a need and then work with the expert's existing knowledge to help them move into new areas of knowledge. So most of the work is actually done by the students and I'm just there to guide them along. (26/10/06)

Timmy's presentation of his classroom experiences was followed by questions and discussion. The following is an excerpt of the teachers' discussion:

Anthony: I'm just interested to know how many computers you have in your school, and has every student got access to using the computers?

Timmy: Actually we've got 10 computers to start in our school and the students were working in three groups of six students per group. Each group had a leader and every student had a turn in using the computer. Working in groups helped them to share their views and ideas.

Gilson: How come you only picked those two tasks like the making of the soap package and the calendars and why not other tasks?

Timmy: I picked these two tasks because I saw them as the immediate needs and they were more current to our situation at the time. We were addressing a need and an opportunity for producing a marketable product, like the task on soap was based on addressing a need and the calendar was based on addressing an opportunity, so the students' tasks were related to our current situations.

Richard: How do your students go about doing the section on marketing?

Timmy: In regards to marketing, the product itself, the calendar already had a potential market and that was the school and students. The students who were working on the calendar knew about places where they could produce them and they worked out how much a calendar would cost.

In Anthony's reflection he pointed out that the technological concepts he had learnt from the workshops had changed his views on how to teach technology. By undertaking this new teaching approach, Anthony felt that his teaching load was lightened as students were given more opportunities to learn by doing things themselves. He said:

In fact, these workshops have really enlightened me on how to teach this subject. By adopting these concepts in my teaching practice, I have been released from overworking myself, and giving the students the opportunity to freely express themselves. This new approach really helped my students think for themselves and they knew why a change needed to be made as they worked through the design process because it was their own ideas. Usually when we teachers designed and decided on the task for the students, the students did not really know why the changes were made in the middle of the project. (26/10/06)

Raymond talked about the design process teaching approach as a linear or sequential approach. He commented that his students now understood that the design process approach began by firstly identifying a need and then it moved through the stages until it ended with an evaluation of the final product. He further added that the sequential nature of the design process teaching approach made it easy to follow and also encouraged his students to enthusiastically participate in conversations. He said:

My students became aware of the whole design process beginning with the identification of needs, designing, and right down to the evaluation of the final solution. The students have been made aware of this design process if they are going to work on a technological task and the students have already enjoyed it. This process also encouraged our students to talk freely and I'd also like to say that this program was very, very helpful because these sequences are really easy to follow as we go through our class tasks. (26/10/06)

In Gilson's reflection, he admitted that although he understood the design process teaching approach, due to being pressured by circumstances which were beyond his control, he was not able to use it. However, he added that he would try the design approach next year. He stated:

I did understand the design process approach which I should have been undertaking when doing this project. However, my teaching approach was 80% teacher-oriented and 20% student-oriented. In other words, 80% of this project was done by the teacher and only 20% of the work was done by the students. The students actually did the work on this project, but most of the decisions on what were to be done were made by me. The reason why I decided to take this approach was simply because we only had a very limited time before exams. But I hope by next year, I should be able to try out this new teaching approach that we have learnt during our workshops this year, as well as giving students the opportunity to try and design their own products. (26/10/06)

Gilson's reflections also raised some questions and comments after he shared his classroom experiences with his colleagues. The following is an excerpt from Gilson and Anthony's discussion.

Anthony: My question to Gilson is this. Were the electronic circuits designed by the students themselves, or were they designed by you, the teacher?

Gilson: The electronic circuits were designed by Dick Smith Company and we were just following it. Although, I now understand that the electronic circuits should be designed by the students themselves. But in my case as I'm pressured by the external examinations, I decided on what the students would do in the classroom. As I said hopefully I will try it next year.

Anthony: I think in teaching electronics students should learn about the uses of the components and how they work and give the students the chance to design their own circuit and the teacher is just there to help them undertake their task.

Ronald talked about the important things he learnt from this PD programme and by listening to his colleagues during the workshops. The following was his statement:

During these four months I've learnt the following things, which I think are important to the teaching of technology education. The first thing I need to do is to find a context for the project that I will teach my students. The second thing is to understand the required processes or the procedures for undertaking the project, which I will include as my learning outcomes. The third thing is how the technology relates with society and not just for the sake of meeting examination requirements. As other colleagues have mentioned that they are focused on societal needs and finding solutions to societal problems. By listening to my colleagues I now have a better understanding of what we have been trying to do in the last four months.

The main theme that arose from the teachers' reflections and sharing time on the second phase of the classroom practice session was that the design process teaching approach had motivated the students and made teaching/learning more exciting. This theme was similar to the theme in the teachers' reflections of Workshop Two. A summary of teachers' reflections on the first phase of classroom practice in Workshop Two and the second phase of classroom practice in Workshop Three is outlined in Table 6.10.

Table 6.10
Summary of teacher reflections in Workshops Two and Three

| | Workshop Two | Workshop Three |
|-----------------|--|--|
| Teachers | Reflection on the first six weeks of classroom practice | Reflection on the whole classroom practice session |
| Raymond | Problems encountered during classroom practice session | Design process teaching approach |
| Gilson | Problems encountered during classroom practice session | Problems encountered during classroom practice session |
| Anthony | New teaching approach | Design process teaching approach |
| Richard | New teaching approach | Design process teaching approach |
| Timmy | New teaching approach | Design process teaching approach |
| Ronald | New teaching approach | Design process teaching approach Learnt from colleagues experiences |
| Zebedee | New teaching approach | Design process teaching approach Learnt from colleagues experiences |

These comparisons show that all the teachers made reference to the design process as the new teaching approach. Although Gilson and Raymond pointed out the problems they encountered during the first part of the classroom practice session, these were related to the new teaching approach they had been introduced to in Workshop One. In Workshop Three, Ronald and Zebedee commented that the teachers' reflections had given them the opportunity to learn from their colleagues' experiences.

Teachers' suggestions on how best to inform other colleagues

After teachers finished with the sharing and discussions based on their classroom experiences, they were given time to make suggestions on how best they could inform their colleagues about what they had learnt from the PD programme. Several suggestions were made by teachers.

- The need to convince the Curriculum Development Center (CDC) of the Ministry of Education to see the significance of PD programmes in relation to the implementation of the newly developed technology syllabus so they can provide these teachers with the necessary support for helping them to inform other colleagues.
- The provision of similar workshops for other teachers to understand the nature of the subject technology. The teachers, however, suggested that the workshops be divided into two categories. The first category should focus on learning about how to teach the new technology syllabus, while the second category should focus on developing

knowledge in specific technological areas in the syllabus. This would help teachers teach technology effectively.

- The development of both the teacher and student resource materials before similar workshops were undertaken. These would help guide teachers and students in undertaking their technology tasks.
- Teachers need to know how to plan their own technology lessons using an outcome-based approach.
- Teachers need to understand the design process approach when teaching technology lessons.
- Teachers need to undertake a student-centred teaching/learning approach.
- Teachers need to know about a problem-solving-based teaching/learning approach when undertaking technology tasks.
- The need for classroom support for teachers when trialling the new approaches, especially a colleague-in-support, as this had helped them gain self confidence in trialling the new teaching approach. They even suggested that they would make themselves available if their colleagues would like to talk to them about their classroom experiences.

Teacher evaluation of the whole professional development programme in 2006

Session two ended with a teacher evaluation exercise. The teachers' evaluation questionnaire in Workshop Three was different from those in Workshops One and Two. The evaluation questionnaire in Workshop Three covered the entire PD programme (see Appendix M). The first part of the evaluation related to teachers' views of technology and technology education (refer Chapter Seven). The findings for the second part of the evaluation questionnaire related to teachers' experiences during classroom practice sessions, including the assessment session in Workshop Two and these data are reported in this chapter.

Reflections on enablers and barriers in classrooms

The aspects teachers found easy to implement and the difficulties they encountered during their classroom practice sessions were also reported. Five teachers, Anthony, Zebedee, Gilson, Timmy and Raymond, indicated that it was easy to implement aspects related to the design process, and mentioned aspects such as identifying a problem/need/opportunity and following the design process as the teaching methods for teaching technology. Other teachers, like Ronald, pointed out that teaching of technical skills was easy to implement, while

Richard stated that identifying the learning outcomes was quite easy to undertake. Six teachers provided comments on the difficulties they encountered during the classroom practice sessions. One teacher, Timmy, did not recall having any difficulties. Of the six, four teachers, Anthony, Zebedee, Gilson and Raymond, stated that lack of resources such as money, materials, tools and time were the difficult aspects they encountered during classroom teaching. Raymond stated that the integration of the societal aspects was his difficulty, while Richard's difficulty was the designing of students' folios. Outlined in Table 6.11 is a summary of themes indicated by teachers as the aspects they considered being easy to implement and the difficulties they encountered during classroom sessions.

Table 6.11

Aspects teachers found easy to implement and difficulties encountered

| Teachers | Easy to implement | Difficulties encountered |
|-----------------|--|--|
| Anthony | Identify problems, need and opportunities | Time schedule of construction phase was not enough No money to buy materials |
| Zebedee | To identify our own tasks to solve problems or meet needs of society | Lack of money to buy resources, and to create new designs |
| Gilson | Investigation, designing and the devising component of the classroom task | Having difficulties with the construction phase, in terms of money, time, knowledge and skills related to electronics. |
| Timmy | It's easy to implement this new concept of technology and its teaching methods | No difficulties have been encountered |
| Ronald | Teaching of technical skills | Integration of the societal aspects or values |
| Raymond | Problem / need / opportunity identification and following the design process | Lack of resources like materials, equipment and tools, and some specific notes |
| Richard | Identifying the learning outcomes from the task content | Devising a folio for the students, and criteria to assess students |

Teachers' reflection on assessment

All seven teachers stated that the session on assessment in Workshop Two changed their existing views of assessment. For example, Raymond's original view of assessment changed

from viewing assessment as a one off, only undertaken at the completion of the task, to assessing students all the way through the task to help them move forward with their classroom activities. He said:

This is unlike my previous assessment practice where students were assessed only once after the unit was completed, like assessing students from unit tests etc. With an understanding of formative assessment, the students are assessed as the task starts to move students forward in their learning. Therefore, the classroom activity assessment in technology education has to be continuous, from the start to the end of the project. (26/10/06)

Richard also pointed out that the session on assessment in Workshop Two helped him to have a better understanding of the differences between summative and formative assessment. He understood summative assessment to be about setting criteria to assess students' finished tasks, and formative assessment to be about helping students' progress with their tasks. He stated:

I now have a better understanding of the two types of assessment used for assessing students. From the assessment session in Workshop Two I've learnt about the criteria to be used for assessing students' finished task in summative assessment, and the idea of getting students to progress to the next level through formative assessment. (26/10/06)

Ronald pointed out that the outlined criteria used for summative assessment of students' tasks were more appropriate for the tasks his students were undertaking. He said:

This session on assessment outlined the criteria that revealed the accurate areas to be assessed in technology and it also is a better reflection of the technology task undertaken by the students. (26/10/06)

Anthony revealed that the assessment session helped him to see how to assess his students. He pointed out that though he had previously applied these forms of assessment in his classes, he thought that he may not have done this well. He commented:

I've already applied the types of assessment in my classes before they were presented to us in Workshop Two. But due to not enough information about these types of assessment it may have been poorly applied in my situation. (26/10/06)

Two other teachers indicated that they had tried out the assessment that they had learnt from the PD programme. Zebedee stated that his experience in implementing the forms of assessment was very interesting and challenging. He said:

I've already put into practice the types of assessment that I learnt from this workshop and it was interesting and challenging. (26/10/06)

Gilson also applied some of these forms of assessment in his class and also experienced some challenges. He stated:

I have applied some of these assessments in my class and found it a bit challenging due to some factors, like my school situation and my administration. For example, the lack of money and materials were the greatest hindrance to assessing all the technological criteria. (26/10/06)

Timmy made comparisons based on his previous view and his recent view of assessment. He pointed out that he now understood formative assessment as advising students to use their potential whenever they got stuck on what to do next. He stated:

Before I used to assess students based on tests and skills performance but never considered the idea of advising students on what to do whenever they got stuck as a form of assessment. My view now on assessment is that I can help students use their potential to undertake new tasks through formative assessment. (26/10/06)

Teachers' reflection on assessment indicated that the assessment sessions made them aware of summative and formative assessment and its place in teaching and learning in technology education.

Teachers' reflected on the learning outcomes their students should be learning

When teachers were asked to explain what they would like their students to learn from the task they had undertaken in class, most teachers made reference to aspects of the design process. The majority of teachers expected their students to learn procedural learning outcomes. For example, Anthony referred to his stated procedural learning outcomes as what he expected his students to learn from their given task. He stated:

I've expected my students to be able to identify situations, brainstorm, design, make and evaluate. (26/10/06)

Gilson also echoed this similar procedural focus. He said:

My students should be able to identify the real life situation, brainstorm, design, make and evaluate. (26/10/06)

Likewise, Timmy made reference to procedural learning outcomes as what he expected students to learn. He stated that:

I was expecting the students to be able to identify needs or solve problems and work with the client and do investigations and make the product. (26/10/06)

The procedural learning outcomes, as the focus of students' learning, were reiterated by Richard. He stated that students would:

Learn to identify a need, and problem, and work towards solving that problem and produce a result in a given situation. (26/10/06)

This remark was also made by Ronald as he briefly stated that:

The students should learn designing, the making process and evaluation. (26/10/06)

Even Zebedee's comment reflected the same expectation as the rest of the other teachers, as he said:

I expected my students to learn the new concepts and the designing approach adapted for technology education. (26/10/06).

Only one teacher, Raymond, stated that he would like his students to learn across all four learning domains in technology education. He commented:

I would like my students to learn about all the dimensions of technology through the key learning areas such as – conceptual, procedural, technical, and societal. (26/10/06).

In sum, the majority of teachers said that the only learning outcomes to focus on for learning were procedural learning outcomes. Only one teacher expected his students to learn from all four categories of learning outcomes as they undertook given tasks.

The teachers' reflections on becoming an effective technology teacher

Teachers made reference to their workshop experiences, and their classroom teaching experiences as they reflected on factors they thought had helped them to be an effective teacher. Raymond pointed out that learning about the nature and the characteristics of technology helped him to be an effective technology teacher. He stated:

The workshops were very helpful in the way that they gave me knowledge about the nature of the subject and its' characteristics. By understanding the nature of technology I can become a more effective technology teacher. (26/10/06)

Gilson also made reference to the workshop experiences for enhancing his views on becoming an effective technology teacher. He specially referenced the use of the lesson plans and the clear guidelines that were provided with them as a means for helping him to be an effective technology teacher. He commented:

The workshops had helped me very much as a technology teacher. They provided me with clear guidelines for planning my lessons which were very easy to follow. By using these lesson plans they help me become an effective technology teacher. (26/10/06)

Richard also reiterated the importance of the lesson planning sessions as the sessions which helped him to become an effective technology teacher. He talked about his lesson plans as becoming focused on student-centred activities. This teaching approach gave him more time to help students with their work. He said:

Indeed the lesson planning sessions have helped me to become an effective technology teacher. My lesson plans are now focused on student-centred activities which give me more time to move around in the classroom and help students with their work. (26/10/06)

On the other hand, Anthony made reference to his classroom experience in dealing with real life issues and by solving community problems as an evidence of an effective technology teacher. He thought that the students' achievement of the technological outcome had indicated that he was an effective teacher. He commented:

My experience in the classroom has proved that I'm an effective technology teacher because my technology task was dealing with real life issues. Not only that, it also solved the problems by meeting the needs of that society. (26/10/06)

Undertaking a problem-solving teaching approach and using real-life contexts for teaching technology were also advocated by Timmy as effective methods. He stated:

Yes, the classroom experiences have helped me to become an effective technology education teacher. Through these past weeks I have experienced this new method of teaching learnt during the workshops. By seeing my students undertake problem-solving in real life situations was exciting and that approach made my teaching effective. (26/10/06)

Zebedee indicated that his classroom teaching experiences had helped him to be a more effective teacher. He said that working alongside individual students in the classroom and helping them with their task was an indication of his being more effective.

This teaching practice helped me a lot to become an effective technology teacher. In my experience, I worked together with the students and provided them with the assistance they needed to get them to the next stage of work. (26/10/06)

Teachers' reflections on students as active learners

When teachers reflected on what they thought had helped their students be more active learners, most teachers made reference to increased student involvement in undertaking the

tasks. Anthony interpreted students' interest in undertaking their task and their accomplishment of it as evidence of active learning. He stated:

Students became effective learners because I've seen that the students had shown greater interest in making the task given to them in class. And by looking at the completed task, the students had achieved what they wanted to learn. (26/10/06)

Zebedee's interpretation of students as active learners was based on students following the design process procedures and getting the task done. As he stated:

As a teacher I needed to be creative in initiating tasks and methods that encouraged students to become actively involved in undertaking the tasks using the design concepts of technology education to achieve the outcomes. (26/10/06)

Getting students to be more involved in classroom activities was again reiterated by Raymond as indicating that his students were active learners. He stated that:

My students are certainly active learners because I gave them more activities to work on and the students were more involved in undertaking those activities. (26/10/06)

Ronald also held this view. Encouraging students to do most of the work themselves was his interpretation of students as active learners. He commented:

That was what I did with my Form Five technology class this year. I allowed the students to do most of the work and got them actively involved in doing the task and I only provided them with assistance whenever it was necessary. (26/10/06)

Timmy's interpretation of students as active learners was also based on students' involvement in undertaking the activities and taking up the responsibility to do their own learning. He stated:

For the students to become active learners, teachers should let them to be responsible for their own learning. Yes, the workshops also helped me a lot by giving me the idea that I should focus more on the students undertaking activities to become active learners. (26/10/06)

In Gilson's interpretation of the view on students as active learners, he pointed out that active learning was when students actively worked on problem-solving activities. He stated that:

By giving the students the problems to solve and allowing them to actively involved in finding a solution. By undertaking this process and have achieved their aims brings a sense of achievement and pride because the problems have been solved or the need has been met. (26/10/06)

Teachers' areas of need for future support

The PD was well received and appreciated by the teachers. However, they also pointed out other areas needing further support. One area which most teachers made reference to was lesson planning, As Anthony commented:

I would like to see more on unit planning in future workshops. (18/7/06)

Gilson also reiterated that he needed more support with the areas on the new teaching approach and activity planning. He said:

I would like to see more on the teaching of teachers to understand this new teaching approach, especially on how to plan activities and how to identify context. (27/8/06)

Another area which teachers also pointed out as needing more support is on effective learning. As Ronald stated:

I would like to see more on effective learning in technology. (27/8/06)

Raymond pointed out that a further workshop was needed to help him further understand the area on learning outcomes. He commented:

Another workshop is needed so that we can further discuss the learning outcomes under conceptual, procedural, technical and societal. I must honestly admit that I need to learn more about these areas. (18/7/06)

The teachers learnt so much from the experience of this PD programme and recommended that other technology teachers should also be given the same opportunity to join future PD programmes. As Zebedee commented:

I suggest that firstly, other technology teachers will also need this kind of workshop. If you could assist with the upgrading of other technology teachers to understand the content in the new syllabus it will be really helpful for all of us when the new syllabus is implemented. (26/8/06)

Another area of support which teachers also need during the implementation of their technology tasks was administrative. Some teachers would like to see more support, especially in the form of finance from their administrators. Raymond pointed out that without financial support from school administrators, the new concepts and practices they had learnt from the workshops could not be successfully implemented. He commented:

The workshop programmes were good but it won't work if the school administrators won't support it financially. So we really need the authority from the Ministry of Education to put the pressure on our principals. (26/10/06)

Another teacher, Timmy, also pointed out that the success of implementation depended very much on the support provided in the classrooms. He stated that classroom support would have been continued by the Curriculum Officer at the Ministry of Education if he was also attending this PD programme. He explained:

I would like to see the Ministry of Education, especially the Curriculum Officers, to be more supportive by attending such workshops so that we all can have the same understandings of technology and to support us in the classroom as we implement these new concepts. (27/8/06)

These forms of teacher support were recommended as significant for the success of the implementation of the new concepts in a classroom level.

Summary of the professional development programme

The third workshop was undertaken in a day and was held as a time for teachers to reflect on the whole exercise, the workshops and their teaching experiences. The workshops and the teacher support provided by the researcher during the classroom practice sessions had expanded the teachers' understanding of technology and technology education. The teacher reflection approach undertaken in the workshops also contributed in widening the teachers understanding of technology and technology education by getting teachers to see their colleagues' views as they made comparisons with their own views, which helped them to learn from each other. Teachers talked at length about the design process teaching approach as the teaching approach they used in teaching technology education. By having a better understanding of the nature of technology, and by undertaking the design process teaching approach in their classroom teaching, the teachers are now more competent and effective technology teachers. As well, teachers also acknowledged that their students had become effective and active learners because they took up the responsibility to learn on their own.

After teachers had been through this PD programme, they made recommendations for getting this sort of programme further and also to help other technology teachers come to terms with technology and technology education concepts and practices. The recommendations suggested that similar workshops should be undertaken with other technology teachers so they too could learn about the new technological concepts and similar teacher support should be provided.

6.4 Chapter Summary

The focus of this chapter was on the PD intervention programme undertaken in 2006. The approach undertaken by this PD programme was based on the principles of PD being ongoing, having a teacher reflection approach, and having teacher sharing and interaction approach. It was seen to be of great benefit to the teacher participants. The ongoing nature of the PD programme undertaken with the workshop days being followed with classroom practice sessions motivated the teacher participants to implement the concepts and practices learnt from the earlier workshops, and encouraged teachers to share their classroom experiences with colleagues in the later workshops. The teacher support approach enabled teachers to build confidence in implementing the new concepts in the classroom setting. The sharing time during the workshops was indicated by teachers as a learning experience. The content delivered in the three workshops contributed positively to teacher change both in their perceptions of technology and technology education, and their classroom practices in technology education. The nature of this PD programme was appreciated by teachers as it was very different from their previous PD programmes. The change in their perceptions was achieved through a better understanding of the nature of technology and technology education. Teachers were also keen to undertake changes to their previous teaching practices as the focus of the PD programme was on best practice and the use of appropriate pedagogies in teaching technology education. The positive outcome experienced by these teachers during their teaching practice had empowered them to embrace the new changes. The teachers' enhanced understanding of the nature of technology and technology education and classroom practices in technology education are discussed in Chapter Seven.

CHAPTER SEVEN:

TEACHERS' CHANGED PERCEPTIONS OF TECHNOLOGY AND TECHNOLOGY EDUCATION AND CLASSROOM PRACTICES: 2006 FINDINGS

7.1 Introduction

Chapter Six discussed the findings related to the professional development programme undertaken in 2006. The findings indicated that the teachers' change of views of technology and technology education, and change of classroom practices were the result of the reading materials provided to the teachers, the workshop activities teachers engaged in, the sharing times integrated into the workshop sessions, and trying out the ideas from the workshops in their classrooms. The nature of the professional development programme with the integrated principles of an ongoing nature, teacher reflection, teacher sharing and interaction, and teacher support was found to be instrumental in moving teachers away from their previously held views of technology as artefact related, technology education technical education, and their traditional classroom practices (prescribed textbook teaching approach, closed tasks, fragmented teaching of theoretical and practical lessons, classroom confined lessons).

This chapter discusses the teachers' changed perceptions of technology and technology education, and their changed classroom practices in technology education as a consequence of the professional development intervention programme in 2006. The discussion in this chapter relates to research question three:

3. What effect and influence does a professional development programme have on teachers' concepts of technology and technology education, and their classroom practices?

These data were generated from seven teachers rather than the original eight, as Jason withdrew on medical grounds. The findings revealed that the professional development intervention programme did impact on the teachers' perceptions of technology and technology education, and their classroom practices in 2006. The

teachers' changed perceptions of technology and technology education are presented in section 7.2, followed by teachers' changed classroom practices in section 7.3. Section 7.4 presents the effects of the teachers' change of teaching practice. The factors that hindered teachers changing their teaching practices are presented in section 7.5. Finally the chapter is summarised in section 7.6.

7.2 Teachers' Changed Perceptions of Technology and Technology Education

This section examines the teachers' perceptions of technology and technology education. The professional development programme impacted on the teachers' perceptions of technology and technology education. Before the professional development programme, the teachers' views of technology were based only on artefacts or artefact related perspectives, and their views of technology education were based on technical education (see Chapter Four). After the professional development programme, the teachers' views of technology and technology education were much broader to include technology as a process used for solving technological problems to meet the needs of society through the combined application of knowledge, skills, and tools/resources, and technology education as design activities with a problem solving focus. This view was expressed by the teachers more than once in their comments made during the workshops, during conversations and in the survey questionnaire undertaken at the end of the professional development programme which indicated the robustness to their change of perceptions. Teachers' enhanced perceptions of technology are presented in section 7.2.1, and section 7.2.2 presents the teachers' enhanced perceptions of technology education.

7.2.1 Teachers' Changed Perceptions of Technology

This section presents the teachers changed views of technology. Previously, teachers viewed technology from narrow, artefact related perspectives which changed to technology as a process used for solving technological problems to meet needs of society. The impact of the reflections teachers undertook during workshop one on their existing perceptions with a range of technology definitions (see Appendix 14) given as reading materials influenced the teachers' perceptions of technology. The details of the teachers' changed views of technology are discussed next.

Technology as a process used for solving technological problems to meet the needs of society

Technology as a process used for solving technological problems to meet the needs of society was the common theme that emerged from the statements made by teachers during the professional development intervention programme in 2006. The teachers changed views of technology were influenced by the range of technology definitions given to teachers to explore in workshop one. They were evident as teachers talked about technology throughout the entire professional development intervention programme in 2006. For example, in Anthony's response to the questionnaire in the third workshop, it was apparent that his view of technology reflected Burns' (1992) view of technology as a process used by individuals, communities, and society to identify technological problems and also seek solutions for resolving them. As he stated:

Technology is the process by which society, communities and individuals identify [technological] problems and seek to solve them. (26/10/06)

In his comments in the third workshop, he also reflected on the discussions of the technology definitions. He highlighted the view shared by Lux (1983) on technology as he talked about the definition of technology in Greek and in English. He said:

When I recalled your explanation of the word technology it has enlightened me. You mentioned that technology is originated from two Greek word; techne and ology, which means practice and knowledge [in English]. In other words, it's what you know that you put into practice. So my understanding now of technology is about knowledge being put into practice to either address the needs, or solve problems of society. (27/8/06)

His perception of technology as a process used for solving technological problem is consistent with his views of technology education (see Anthony's view in section 7.2.2). In both views, Anthony highlighted the idea of solving technological problems to meet societal needs.

Timmy reiterated the view that technology was to do with solving technological problems to address the needs of society. As he commented during a conversation;

I think technology is about solving [technological] problems and addressing needs in society. (4/8/06)

In response to the questionnaire at the end of workshop three, he reiterated the view of technology shared by Johnson (1989) on technology as the process of doing something to meet societal needs and to solve problems involving the use of tools and machines. He stated that:

Technology is a process of doing something along with tools and machines to accomplish a particular task to meet the needs of society, or solve the technological problems of society. (26/8/06)

His view of technology as a process for solving technological problems was similar to his view of technology education (see Timmy's view in section 7.2.2). In both views he mentioned the idea of solving technological problems to meet societal needs.

This similar view of technology was highlighted by Raymond in workshop two. He agreed that technology was a process used for solving technological problems to meet the societal needs. He said:

Now I see that technology is focused on addressing needs in society as our colleagues had already expressed that technology is basically to solve problems or to address needs in society today. (27/9/06)

He also viewed technology as a process for solving technological problems that meet societal needs through products, systems and environment. He added that societal needs and opportunities vary between different societies and are influenced by each of the society's value judgments. His view of technology outlined in response to the questionnaire also advocated the view outlined in the New Zealand MoE (1995) document. He stated:

Technology involves meeting societal needs and opportunities through a wide range of activities within a society. Thus each specific society has its own needs and opportunities in terms of products, systems and environments which are influenced by value judgments. (26/10/06)

Raymond understood technology as a technological problem solving, so too was his view on technology education (see section 7.2.2).

The view of technology as an approach to problem solving to meet the needs of society was also highlighted by Zebedee during workshop two. He commented:

I think technology is dealing with real life issues and it also about solving [technological] problems by meeting the needs of society. (27/8/06)

In response to the questionnaire, he pointed out that the process by which societal needs were being met was through the development of products either by creating a new design, or by improving existing design.

Technology is a process of meeting needs through the development of products, which have been classified into two areas – new design and improving old design. (26/10/06)

Zebedee's view of technology is very similar to the way in which he perceived technology education. In both views he talked about technology and technology education as a process used for meeting needs of society (see Zebedee's view in section 7.2.2).

Richard's view of technology as technological problem solving was also influenced by the technology definitions. In a conversation, Richard pointed out that technology is about addressing the technological problems in real life situations in society and aimed at meeting societal needs. The view of technology as a problem solving process was highlighted in almost all the technology definition (see Appendix 14) given to teachers. He commented:

Technology is about addressing societal needs, or solving [technological] problems in a real life situation. (22/8/06)

In a conversation with Gilson, he highlighted that technology involved knowledge, skills and values. Gilson's perceptions of technology as knowledge, skills and values as the three significant aspects for the existence of technology in society were also influenced by the technology definitions (see Appendix 14). He said:

I think technology covers knowledge, technical practice and skills, and societal values. For example, technology would not exist if people don't have the knowledge and skills to make it and it will never be accepted in society if it is not valued by people. (26/9/06)

From the questionnaire, both teachers, Richard and Gilson viewed technology as the combined use of technological knowledge, skills and tools/resources for solving society's technological problems. Richard stated that:

Technology is an application of knowledge, skills and resources to solve practical problems in a real life situation. 26/10/06

Gilson stated that:

Technology is an application of knowledge, tools and skills to solve technological problems to meet the current need of certain individuals (a customer) or society. (26/10/06)

Both teachers' view of technology reflected the combined application of knowledge, skills, resources and tools for solving technological problems of societies or individuals as advocated by Johnson (1989) and UNESCO, (1986) in the technology definition (see Appendix 14).

Ronald's perception of technology had a slight twist, as he talked about the problem solving comparing traditional with modern technology. He pointed out that the replacement of the old slow and hard way of doing things with the much faster and easier way of doing things is a technological problem being solved. As he stated in his response to the questionnaire:

Technology is about solving people's [technological] problems. For example, technology has solved the old slow and hard way of doing things and it has enabled people now to do things faster and easier. (26/10/06)

All seven teachers perceived technology to be a process used for solving problems to meet the needs of society. Collectively, the teachers' changed perceptions of technology became focused on the process of identifying needs and problems of individuals or societies. It involved seeking solutions to solve those technological problems, or to meet those needs by developing appropriate products. Through this problem solving process, the combined use of knowledge, skills, tools and resources would be employed. The teachers' change in their views of technology was strongly influenced by the definitions of technology given to teachers in workshop one.

Comparison summary of 2005 and 2006 findings of teachers' perceptions of technology

This section summarises and compares the 2005 and 2006 findings of the teachers' views of technology. Table 7.1: Summary table on 2005 and 2006 findings of teachers' perceptions of technology shows the teachers' previously held perceptions of technology in 2005 and the teachers' changed perceptions of technology in 2006.

Table 7.1:
Summary of 2005 and 2006 findings of teachers' perceptions of technology

| Teachers | Findings on teachers' perceptions of technology | |
|----------------------------|---|--|
| | 2005 | 2006 |
| Anthony Timmy Ronald | making something | a process used for solving technological problems to meet the needs of society |
| Raymond Zebedee | applied knowledge | |
| Richard Gilson | artefacts (computers) artefacts (cars) | |

The table reveals that teachers' perceptions of technology in 2006 had changed from 2005. The teachers' perceptions of technology in 2005 findings were categorised in three themes of technology as making something technology as applied knowledge, and technology as artefacts. The teachers' changed perceptions of technology in 2006 findings were categorised in one theme as technology as a process used for solving problems to meet the needs of society. All seven teachers changed to this view. This view of technology is consistent with the views they held about technology education as design activities with a problem solving focus.

7.2.2 Teachers' Changed Perceptions of Technology Education

The professional development programme also impacted on the teachers' perceptions of technology education. Before the professional development programme, the teachers' view of technology education was that it was technical education. After the professional development programme the teachers' views of technology education were much broader to include technology education as design activities with a problem solving focus. The details of the teachers' changed views of technology education are discussed next.

Technology education as design activities with a problem solving focus

Technology education as design activities with a problem solving focus was the common theme that emerged from statements made by teachers during the PD programme and during conversations I had with teachers in classrooms. The design activities with a problem solving focus that teachers undertook as a technological pedagogy in teaching their technology tasks in 2006 significantly influenced the

teachers' perceptions of technology education. When teachers talked about technology education, they often referred to the design activities they undertook with their students as problem solving tasks. For example, from a conversation I had with Richard in his classroom, he commented that technology education was unique because it had its own teaching approach, using design activities with the problem solving approach. He said:

Now I see that teaching of technology is different from Industrial Arts. In Industrial Arts, the students' projects were determined by the type of joint stated in the syllabus. I'm now teaching technology because I've started with a problem solving approach using the design process. The students were given a situation, and they were asked to think of an item that could be used for keeping their valuable personal items safe from burglars, which they could use either at home or in their dormitories at school. (24/7/06)

Likewise, Richard viewed technology education as design activities with a problem solving focus. His view of technology education was similar to technology as he reiterated the significance of assisting students to develop technological knowledge, skills and values for the purpose of solving problems and addressing the needs of various communities. He commented:

In my view, technology education is geared towards helping students to develop knowledge, skills and values to address needs, opportunities or solving problems in a society, community, at schools and homes. (26/10/06)

In his response to the questionnaire from the third workshop, he also highlighted that technology education has a double skills component. These were the cognitive skills and technical skills which he believed to be significant for design activities and problem solving in technology education. Richard said:

Technology education enables students to develop both cognitive skills and technical skills to address situations or solve [technological] problems in a more meaningful manner. (26/10/06)

Likewise, when Timmy commented on technology education in workshop two, he pointed out that students need to be engaged in design activities and problem solving tasks. He added that when students got involved in solving design problem tasks, they undertook such tasks as developing design briefs, and making things, using a list of specifications to solve the technological problems. Timmy's view of technology education was influenced by his classroom activity, as he said:

In my technology class, the students had to start with a design problem, and they had to write down the problem which they were trying to solve. After the design problem was clearly stated then they can develop their design brief and a list of specifications to be considered for solving the problem. (27/8/06)

In a conversation, Timmy also pointed out that students need to identify needs in society, then, acquire know-how knowledge for solving the technological problems in addressing societal needs. He commented that students could further enhance know-how knowledge if they actually worked closely with experts from the same fields as their technology tasks. This view was reflected in his class activity in 2006 as he sent his students into the community to gather information for their technology task. He said:

The main thing that I see in technology education is how to identify societal needs and getting students to work with the experts in their field of specialty. This will enable the students to get directions from the experts to move them on to learning new knowledge which should also help them to get their tasks completed, and, at the same time address the societal need. (26/9/06)

Additionally Timmy, in his response to the questionnaire, stated that technology education also educated students to understand and become aware of the inter-relationship between technology and society. His view of technology education highlighted in the questionnaire also advocated his view of technology which influenced by the technology definitions (see Appendix 14). He stated that:

Apart from developing technological knowledge and capability, technology education also helps students to develop an understanding and awareness of the inter-relationship between technology and society. (26/10/06)

Gilson also viewed technology education as design activities with a problem solving focus, although he did not use the design process approach in teaching his technology task in 2006. His view of technology education, which he highlighted in the discussion in workshop two, advocated his view of technology (see section 7.2.1) which was influenced by the technology definitions. He explained:

Anyway, even though I'm not really following the approach for teaching technology, my understanding of technology education is about involving students in addressing a need, or solving a [technological] problem in a real life situation by developing a design brief using the design process. (27/8/06)

He also commented in the third workshop that he believed the design process was the key approach to teaching of technology education. He highlighted that he was not

quite teaching the whole of technology education because the designing aspect was missing from his technology lesson. He commented:

I'm only teaching ¾ of technology because after I had given the students some notes on the procedures for making the project, I then asked the students to go straight into the making part of the project without following the problem solving approach using the design process. (26/10/06)

In his response to the questionnaire in workshop three, he added that students developing technological knowledge and know-how knowledge, both of which could be used to solve technological problems and meet societal needs, are significant aspects of technology education. He commented:

Technology education is about developing technological knowledge and understanding, understanding problems and needs in society, and to have the know-how knowledge to solve them. (26/10/06)

Ronald also held the same view of technology as design activities with a problem solving focus as seen in his response to the questionnaire from the third workshop. He perceived technology education as the avenue for learning about technological problem solving. As he commented:

Technology education is the path that teachers and students follow as a guide to solve the problems of today's society. And it is through the technology classroom activities that enabled them to learn how to solve that problem or at least learn to find a solution. (26/10/06)

He reiterated the significance of considering the societal issues in technology education in workshop two. The main societal issue he highlighted was the significance of the projects in terms of their values to the community and society. He said:

In teaching technology education, I started by identifying a context within the society. I then looked for a [technological] problem which is to be addressed within that context, and then I asked my students to undertake it as a class task. The next thing I looked at were the skills to be taught. And not forgetting that the concept of the project must also be valued by society or our community. (27/8/06)

Raymond also held the view of technology education as design activities with a problem solving focus. During the second workshop, Raymond talked about technology education as having two parts for undertaking design problem solving tasks; (a) the designing part and (b) the making part. As he commented:

I see technology education as learning about designing a solution to a problem and making the designed product to be used for its purpose. (27/8/06)

In response to the questionnaire, he reiterated his view on the design process as a formal planned technological process which includes the development of technological knowledge through the use of the planned technological process to undertake their technology activities. His view of technology was influenced by the definition of technology education given to teachers as reading materials. He commented:

Technology Education is about developing technological knowledge and understanding and engaging students in purposeful activities, formally following planned technological processes such as the design process. (26/10/06)

In response to the questionnaire, Zebedee mentioned that technology education has its own specific teaching approach. His view of technology education as a subject that has its own principles and teaching approaches was influenced by the reading materials given to teachers in workshop one. He stated:

Technology education has its principles and teaching approach as guides to follow in acquiring technological knowledge and to achieve needs for situations in society. (26/10/06)

The impact of the professional development programme influenced Anthony's views of technology education and helped him to see technology education in a broader sense. The four domains (conceptual, procedural, technical, and societal) used by teachers to plan their technology lessons in workshop one were highlighted as he made comparisons with the technical education he had been teaching for the at least 25 years. He commented:

Our first workshop helped me to see the idea of helping students to understand the four domains - conceptual, procedural, technical, and societal in technology education. From these concepts I began to see that I've been teaching only one aspect of technology education for the last 25 years, and that is just the technical skills, or only the making part. Now I can see that technology education also has other parts apart from just technical skills. I see the societal aspect is very important as it gets students to see the value of the things that they made in class in terms of their usefulness in society. It is also an area that students will get to learn about selling and marketing of their ideas and products to their community. (26/10/06)

During the third workshop he reiterated his view of technology education as technical education with more focus on practical activities, skills, and also encompassing societal aspects. He stated:

Technology education involves a lot of practical activities like teaching of technical skills with an integration of the societal aspects like considering societal values. (26/10/06)

The professional development impacted on teachers' perceptions of technology education. All seven teachers made reference to technology education as being design activities with a problem solving focus to meet needs of society. This view of technology education was consistently highlighted by all seven teachers throughout the professional development programme, indicating the robustness of the teachers' perceptions of technology education. The teachers' enhanced views of technology education were influenced by the teachers' developing technology lesson plans in workshop one, their classroom experiences in undertaking the design process teaching approach, and the reading materials given to teachers in the workshops.

Comparison of 2005 and 2006 findings of the teachers' perceptions of technology education

This section summarises and compares the findings of the teachers' views of technology education in 2005 and 2006. Table 7.2 shows the teachers' previously held perceptions of technology education in 2005 and the teachers' enhanced perceptions of technology education in 2006.

Table 7.2:
Summary table on 2005 and 2006 findings of teachers' perceptions of technology education

| Teachers | Findings on teachers' perceptions of technology education | |
|-----------------|--|-----------------------------|
| | 2005 | 2006 |
| Anthony | creative activity education | |
| Richard | | |
| Timmy | | as design activities with a |
| Raymond | technical hands-on activity | problem solving focus |
| Zebedee | education | |
| Gilson | | |
| Ronald | | |

The PD programme focused on enhancing the teachers' perceptions of technology education. The conclusion is that its effects were consistent for all teachers. That is, the teachers' previous views of technology education changed as teachers perceptions altered to view technology education as design activities with a problem solving focus. Table 7.2 revealed the teachers' perceptions of technology education in 2005 and their changed perceptions in 2006. The teachers' perceptions of technology education in 2005 findings were categorised in two themes; technology education as creative and innovative education and as technical education. The teachers' changed perceptions of technology education in 2006 findings were categorised under one theme; technology education as design activities with a problem solving focus. The table indicates that the two main views of technology held by the eight teachers in 2005 had changed to a single view. All seven teachers who took part in the questionnaire in 2006 indicated a change of perception of technology education and now understood technology education to be design activities with a problem solving focus.

7.3 Teachers' Change of Classroom Practices

This section examines the teachers' change of classroom practices. Prior to the PD intervention programme, the teachers' traditional classroom practices were mainly textbook-based teaching, with closed tasks, a fragmented teaching of theoretical and practical lessons, classroom confined lessons, and with a limited understanding of assessment for learning. The impact of the PD programme saw changes to the teachers' teaching practices in 2006. Discussions of these changes are based on classroom observation data generated by seven of the eight teachers. Jason was unable to participate in the classroom studies even though he attended two of the three workshops. Section 7.3.1 outlines the teachers' 2006 technology lesson plans. The teachers' changed teaching approaches are discussed in section 7.3.2 and section 7.3.3 examines the teachers' enhanced assessment practices.

7.3.1 Teachers' Technology Lesson Planning

In 2005, half of the teachers' based their teachings on the MoE produced text books, while the other half planned their own lessons. However, neither group had clearly stated learning outcomes (see section 5.2: Teachers' teaching documents). The PD intervention programme provided the teachers with the opportunity to plan their own

lessons for teaching selected technology classes in the second semester of 2006. The teachers were asked to either think of a new technology task to teach in semester two or to adjust their existing tasks they had already decided to teach. Based on the selected technology tasks, the teachers identified clear learning outcomes under four learning domains: conceptual, procedural, technical and societal. The teachers' programme of work with the theoretical and practical lessons in sequence used three phases; designing and devising, construction, and evaluation. The example lesson plan format was given to teachers to follow as a guideline (see Figure 6.2 and Figure 6.3). The details of the teachers' lesson plans and their programme of work are examined next.

This section discusses three of the seven teachers' lesson plans. Further evidence of the changes made to their technology lesson planning see Appendix O as all lesson plans were similar. Shown below in Figure 7.1 is the unit task that Zebedee planned for his Form Four technology class in the second semester of 2006. He decided to use an existing task which he had already decided to teach in that semester. By using this lesson plan format (Figure 7.1), Zebedee's lesson plan was organised under task definition, overall dimension of technology and the learning outcomes.

Figure 7.1
Zebedee's lesson plan

| Planning for Learning in Technology Education | | | |
|--|--|--|---|
| Task Definition Design and construct a metal frame stool to be used by students in the science laboratory | | | |
| Overall Dimension of Technology | | | |
| Conceptual – Explore the key principles to be considered when designing a stool | | | |
| Procedural – Construct the metal stool for students in the science laboratory - Describe and evaluate activities | | | |
| Technical – Demonstrate 2D and 3D technical drawing skills - Demonstrate specific skills required for constructing a metal stool | | | |
| Societal – Identifying of both staff and students' (targeted market group) preferences for the science laboratory stool | | | |
| Conceptual Learning Outcomes | Procedural Learning Outcomes | Technical Learning Outcomes | Societal Learning Outcomes |
| Understand that: - an appropriate structure is an important aspect of a stool for strength and balance - Ergonomics and aesthetics are also important parts of the stool design. | Understand: - the safety procedures of using the welding machines and other equipment/tools - the process of investigation and researching a design for the stool product - the process of designing to making of the stool project - the techniques and procedures required for using a welding machine and other equipment and required tools – grinder, spoke shave, plan - how to evaluate the stool as a product and the outcomes in serving its purpose | Be able to: - do technical drawing – isometric, orthographic and ellipse drawings - do technical skills such as; measuring, hack sawing, arch welding, grinding, planning, sanding, spoke shaving, painting and varnishing | - Understand that different people have different preferences of stools in terms of its ergonomics and aesthetics |

As shown in Zebedee's lesson plan (Figure 7.1), his defined task was based on the construction of a metal frame stool to be used in the school science laboratory. The technology task that he decided to undertake as his defined task was to address a need of his school, and that was to construct some stools for the newly completed science laboratory. With the use of the lesson format he was able to outline his lessons using the outcome based approach planning. His generic learning outcomes were written under the overall dimensions of technology and specific learning outcomes under these four learning domains; conceptual, procedural, technical, and societal. The generic learning outcomes under conceptual, were focused on key principles to be considered for designing stool seats, procedural outcomes were based on the construction and evaluation process, while technical outcomes focused on acquiring skills required for technical drawings and construction. Societal outcomes were based on seeking the user's preferences.

Zebedee's specific learning outcomes were derived from his general learning outcomes stated as overall dimensions of technology. He had two specific conceptual learning outcomes. The first, was the consideration of the structural principles which took into accounts the balance and strength of the metal stool. The second, was the consideration of the design principles which took into account the ergonomic and aesthetic aspects. Under procedural, he had five specific learning outcomes. The first, was the awareness of safety procedures when using welding machines and other tools during the construction phase. The second, was the process required when research/investigation is undertaken. The third, focussed on the design and the making process, and the fourth, was the techniques required for handling the machines and tools during the construction phase. The fifth, was the evaluation process. Under technical, he had two specific learning outcomes. The first, was focused on technical drawing skills, and the second, on technical manual skills in using appropriate tools. Finally, under the societal specific learning outcomes, the focus was mainly on the awareness of people's preferences in the manufactured product. Though Zebedee placed more emphasis on the procedural and technical learning outcomes, and less on conceptual and societal in his lesson plan, he still planned for learning outcomes in all four categories.

Zebedee planned his Form Four technology lesson sequence to be covered within an estimated period of 13 weeks (see Figure 7.2: Zebedee's programme of work). His programme of work consisted of student activities to be undertaken through three phases of the design process (investigation, designing and devising phase, construction phase, and evaluation and market promotion phase).

Figure 7.2
Zebedee's programme of work

| Semester two Unit Planner - 2006 | | |
|----------------------------------|--|--|
| Weeks | Design Process Phases | Activities |
| Week 1 | Investigation, Designing and Devising ↓ | Identify context – Real life situation, News papers, Community based information etc |
| | | Brain storm – to identify & select the technological task |
| Week 2 | | Develop design brief or task definition |
| | | Identify the appropriate strands (learning areas) related to the task defined |
| | | Consider the stake holders involved and include them in the investigation process |
| Week 3 | | List specifications required for constructing the task |
| | Devising initial ideas | |
| | Designing the initial concepts – 2D/3D – Drawing skills | |
| Week 4 | | Technical drawing skills – Orthographic & Pictorial - Isometric/oblique |
| | More investigation and research – Technological & societal knowledge/concepts | |
| | <ul style="list-style-type: none"> Interviews/surveys – develop questionnaires Recorded/researched notes - Communication skills | |
| Week 5 | | Identify relevant technological / scientific concepts related to the product |
| | <ul style="list-style-type: none"> Note taking – uses of the product, required design & scientific principles Research and note taking - | |
| Week 6 | | Reassess/evaluate the designing and devising process |
| | <ul style="list-style-type: none"> Self/peer analysis Teacher/client analysis | |
| Week 7 | Construction Phase ↓ | Students construct their designed products |
| | | Knowledge/skills to be taught/learnt |
| Week 8 | | - measuring and cutting of the metals into require lengths |
| | | Knowledge/skills to be taught/learnt |
| | - Welding lesson and practices on the job – welding the metal frames to be used for the base of the stool | |
| Week 9 | | - Grinding lesson and practices on the job – grinding off rough surfaces on the welded joints for smooth finish. |
| | Knowledge/skills to be taught/learnt | |
| | Painting lessons and practice on the metal frames | |
| Week 10 | | Marking out, cutting and planning of the wood board for the stool top |
| | Knowledge/skills to be taught/learnt | |
| | Sanding and varnishing of the wooden top | |
| Week 11 | Evaluation and marketing promotion ↓ | Evaluation of the project |
| | | Students' final appraisal of their tasks as they reflected on the finished tasks |
| Week 12 | | Final presentation |
| Week 13 | | Promotion and Marketing |

Zebedee's programme of work was planned to be undertaken in 13 weeks of the 20 weeks of semester two in 2006. In using this format to organise his lessons in sequence, he decided to cover the investigation, designing and devising phase in six weeks. He also decided to use the same activities as given in the example programme of work (see Figure 6.3). The activities included identifying the context, developing design brief and specifications, developing initial ideas using 2D and 3D technical drawings, investigating and researching more ideas, taking related notes, reassessing and evaluating the initial design idea or concepts. The construction phase was planned to be covered in four weeks. Under the construction phase, he planned to teach the technical skills of metalworking skills, like cutting, welding, and grinding; woodworking skills such as planing and shaping; and finishing skills, such as painting and varnishing. The evaluation and marketing promotion phase was planned to be

covered in three weeks, and he decided to use the same activities as in the example under evaluation, marketing and promotion (see Figure 6.3).

Shown in Figure 7.3 is Anthony’s lesson plan for the Form Four technology class which he taught in the second semester of 2006. Anthony’s lesson plan included a task definition, generic learning outcomes under the overall dimension of technology and specific learning outcomes under conceptual, procedural, technical, and societal.

Figure 7.3
Anthony’s lesson plan

| Planning for Learning in Technology Education | | | |
|--|--|---|--|
| Task Definition Design and construct a coconut scraper for the Home Science department at School. | | | |
| Overall Dimension of Technology Conceptual – Identify key design principles of designing a coconut scraper. Procedural – Design and construct to meet needs Technical – Demonstrate design and technical drawing skills, and skilfully using of hand tools Societal – Identify the preferences of clients for a coconut scraper | | | |
| Conceptual Learning Outcomes | Procedural Learning Outcomes | Technical Learning Outcomes | Societal Learning Outcomes |
| Understand that <ul style="list-style-type: none"> - the strength and balance is an important aspect of the coconut scraper - the scraper must serve its intended purpose – to be used for removing the coconut content - suitable materials are required to be used for making the coconut scraper - the distinctive features of their products are the marketing feature for communicating and promoting of their products | Understand: <ul style="list-style-type: none"> - the procedures required for designing the coconut scraper - the process required for making the coconut scraper from start to finish - the safety and the step by step procedures when using required tools- saw, plan, file, drilling machine, hacksaw. - the evaluation process for assessing the coconut scraper | Be able to: <ul style="list-style-type: none"> - use technical drawing skills to draw 3D pictorial drawings and 2D working drawings - do technical skills like measuring, marking out, cutting, planning, filing, drilling, joining, cramping, squaring, sanding, finish with varnishing / painting | Understand that different people (client) have different preferences for their preferred coconut scraper |

As shown in Figure 7.3, Anthony’s task definition was to design and make a coconut scraper for the Home Science department at his school. Anthony used the Home Science department as the context because the Home Science teacher had asked him if his department could make some coconut scrapers for her to use in her teaching. The context of this task was addressing school needs, and with the use of these lesson plan

formats, he was able to outline his learning outcomes and plan his lesson sequences. Anthony's generic learning outcome under conceptual was focused on the key principles for designing coconut scrapers. His general learning outcome under procedural was based on design and construction, and under technical was based on technical drawing skills and manual skills for using hand tools. Under the societal dimension, the focus was on seeking the users' preferences. Anthony's specific learning outcomes were an expansion of his generic learning outcomes as stated under the overall dimensions of technology. Anthony had four specific learning outcomes under conceptual, and these were focused on the principles of strength and balance, the function of the product, the suitability of the materials, and the marketing strategies for selling the products. He also had four specific learning outcomes under procedural, which focused on the design process, the required procedures for construction process, the safety requirements and the process for working with the tools and the evaluation process. The two specific technical learning outcomes were mainly focused on the technical drawing and manual skills required for using various tools, while societal learning outcome was focused on the understanding of people's preferences.

Anthony's next lesson plan was his time schedule for his technology programme of work for semester two of 2006. Like Zebedee's, Anthony's programme of work was organised into weeks, design process phases and activities (see Figure 7.4: Anthony's programme of work).

Figure 7.4:
Anthony's programme of work

Semester two Unit Planner - 2006

| Weeks | Design Process Phases | Activities |
|---------|--|--|
| Week 1 | Investigation, Designing and Devising ↓ | Identify context – Real life situation, News papers, Community based information etc |
| Week 2 | | Brain storm – to identify & select the technological task |
| | | Develop design brief or task definition |
| | | Identify the appropriate strands (learning areas) related to the task defined |
| | | Consider the stake holders involved and include them in the investigation process |
| | | List specifications required for constructing the task |
| Week 3 | | Devising initial ideas |
| | | Designing the initial concepts – 2D/3D – Drawing skills |
| Week 4 | | Technical drawing skills – Orthographic & Pictorial - Isometric/oblique |
| | | More investigation and research – Technological & societal knowledge/concepts |
| | | <ul style="list-style-type: none"> Interviews/surveys – develop questionnaires Recorded/researched notes - Communication skills |
| Week 5 | | Identify relevant technological / scientific concepts related to the product |
| | | <ul style="list-style-type: none"> Note taking – uses of the product, required design & scientific principles Research and note taking - |
| Week 6 | | Reassess/evaluate the designing and devising process |
| | | <ul style="list-style-type: none"> Self/peer analysis Teacher/client analysis |
| Week 7 | Construction Phase ↓ | Students construct their designed products |
| | | Knowledge/skills to be taught/learnt |
| Week 8 | | - Cutting the wooden frames to its right lengths – lessons on using hand saws |
| | | Knowledge/skills to be taught/learnt |
| | | - Planning the timbers to its right thickness – lessons on using hand plans |
| Week 9 | | Knowledge/skills to be taught/learnt |
| | | Cutting and chiseling the joints of the wooden frames – lessons on using hand saws and chisels |
| Week 10 | Knowledge/skills to be taught/learnt | |
| | Gluing and nailing the wooden frames together | |
| Week 11 | ↓ | Knowledge/skills to be taught/learnt |
| | | Lessons on metal properties and filing |
| Week 12 | | Cutting and shaping of the metal part of the coconut scraper |
| | | Knowledge/skills to be taught/learnt |
| | Screw the metal part of the scraper on to the wooden frame | |
| Week 13 | Knowledge/skills to be taught/learnt | |
| | Sanding / painting the frame of the coconut scraper | |
| Week 14 | Evaluation and marketing promotion ↓ | Evaluation of the project |
| | | Students' final assessment of their task as they reflected on their finish task |
| Week 15 | | Final presentation |
| Week 16 | | Promotion and Marketing |

As shown in Figure 7.4, Anthony planned for his students to work over 16 weeks in semester two of 2006. He planned to cover the investigation, designing and devising phase in six weeks. Anthony also adopted the activities as given in the example lesson plan format under investigation, designing and devising (see Figure 6.3). The activities included identifying the context, developing design brief and specifications, developing initial ideas using 2D and 3D technical drawings, investigating and researching more ideas, taking related notes, reassessing and evaluating the initial design idea or concepts. He planned the construction phase to be covered in seven weeks. Under the construction phase he planned to teach the following technical skills: the woodworking skills of cutting, planning, chiseling, gluing and nailing; metalworking skills of cutting, filing and shaping, and screwing; and finishing skills

of sanding and varnishing. Finally, he planned to cover the evaluation and marketing promotion phase in three weeks, and he decided to use the activities given in the example lesson plan format (see Figure, 6.3).

The example lesson plan format was also used by Timmy (as shown in Figure 7.5: Timmy’s lesson plan) when he planned his lesson for his Form Two technology class in the second semester of 2006. Therefore, his lesson plan was also organised under the three categories used by the other teachers, task definition, generic learning outcomes stated as overall dimension of technology and specific learning outcomes written under conceptual, procedural, technical and societal.

Figure 7.5
Timmy’s lesson plan

| Planning for Learning in Technology Education | | | |
|---|---|---|--|
| Task Definition Design and construct a 2007 year calendar to be sold as school souvenirs to students leaving school used at school Design and construct a soap package to be used for the soap bars made at school by the Form One science students | | | |
| Overall Dimension of Technology Conceptual – Examine the existing designs and use of calendars and range of soap package Procedural – Evaluate the design and construct a calendar for a client / soap package for the school made soap bars Technical – Demonstrate technical drawing skills and basic computer skills Societal – Identify the range of preferences people have on the contrast of colours / pictures | | | |
| Conceptual Learning Outcomes | Procedural Learning Outcomes | Technical Learning Outcomes | Societal Learning Outcomes |
| Understand that by examining existing designs and products can enlighten students with better understanding to pursue their new design and product Understand the design principles – aesthetics - colours - pictures - appealing headings Understand that an attractive package helps sell the soap product and a calendar that students can relate to is targeting student market | Understand the procedures for: - Examining and evaluating existing calendars/ soap packages - Designing the calendars and soap package using the design process - Using a digital camera, and computer for designing of the calendar and soap package - Evaluating their calendar and soap packages - Communicating and marketing of the calendar and the soap package | Be able to: - Do 2D technical drawing - Use computers and printers - Use digital cameras to take photos of buildings, flowers, students etc, | Understand that different people have different preferences for the contrast of colours and pictures |

Unlike the rest of the teachers who only had one defined task, Timmy planned his lesson with two defined tasks. One of his tasks was to design and construct a 2007 calendar to be sold as a school souvenir to students leaving school and the other was to design a soap package to be used for the soap bars made by the Form One science

students at school. The two tasks were intended to be done by his Form Two technology class. He planned to have two groups of students to undertake the first task and one group to undertake the second. Timmy decided to undertake these two tasks as his technology tasks so his students could learn to design using computers. Furthermore, the first task addressed an opportunity market for the school while the second task addressed a need in getting the Form One made soap product packaged. With the use of the lesson format he was able to outline his learning outcomes. His generic and specific learning outcomes for both tasks were stated together in the same lesson plan, and were written in a way to cover both tasks. Timmy's generic learning outcome under conceptual was focused on examining existing products based on soap packaging and calendars, and his procedural dimension was focused on evaluation of the existing products. His technical dimension was focused on technical drawing skills and computing skills. His societal dimension was focused on people's preferences for colours.

Timmy's specific learning outcomes were an expansion of his generic learning outcomes stated as overall dimensions of technology. He had three specific learning outcomes under conceptual which covered both tasks, and were firstly, the understanding of evaluating an existing calendar or soap product; and secondly, understanding design principles; and thirdly, understanding the principles of marketing of the calendar and the soap. There are four specific learning outcomes under the procedural and they were focused firstly, on the procedure for evaluating existing calendar and soap package products; secondly, on the procedure for designing the soap package and the calendar; thirdly, on the procedure for evaluating the finished soap package and the calendar; and fourthly, on the procedure for marketing the finished products. The three specific learning outcomes under technical were focused on firstly, the technical drawing skills; secondly, on the computing skills; and thirdly on camera skills. Finally, the learning outcome under the societal aspects was focused on the understanding of the range of views different people normally have on such a product that the student had undertaken.

In planning a programme of work, Timmy also used the same format which was used by the rest of the teachers. Timmy's programme of work was also organised under three categories, weeks, design process phases and activities as shown in Figure 7.6.

Figure 7.6
Timmy's programme of work

| Semester two Unit Planner - 2006 | | | |
|----------------------------------|--|--|---|
| Weeks | Design Process Phases | Activities | |
| Week 1 | Investigation, Designing and Devising ↓ | Identify the appropriate learning areas related to the task – Information and communication technology | |
| | | Identify context – school context and community context | |
| Week 2 | | Develop design brief or task definition | |
| | | Investigate Ideas – develop questionnaires – conduct survey | |
| | | Consider the stake holders involved and include them in the investigation process | |
| Week 3 | | Visit relevant industries to investigate new information which to inform the development of the task | |
| | Brain storm and list specifications required for constructing the task | | |
| | Devising initial ideas for the design of the soap package and the calendar | | |
| | Designing the initial concepts – 2D – Drawing skills | | |
| Week 4 | ↓ | Knowledge/skills to be taught/learnt | |
| | | • Basic computer skills - | |
| | | • - use of the computer keyboard and mouse | |
| Week 5 | | Reassess/evaluate the initial design and the devising process | |
| | | • Self/peer analysis | |
| | | • Teacher/client analysis | |
| Week 6 | ↓ | Knowledge/skills to be taught/learnt | |
| | | • Computer programmes | |
| | | • – words arts, and word publisher | |
| Week 7 | | Construction Phase ↓ | Students construct their designed products |
| | | | Design initial ideas using computers |
| | | | Using computer to design the initial ideas of the soap package and the school calendars |
| Week 8 | Knowledge/skills to be taught/learnt | | |
| | Inserting photos - using pictures form the computers | | |
| | Printing from the computers | | |
| Week 9 | ↓ | Knowledge/skills to be taught/learnt | |
| | | - Inserting students photo's into the computers | |
| | | Rearranging of photos and setting of the calendar and the soap package lay out | |
| Week 10 | | Print out the first samples | |
| | | | |
| | | | |
| Week 11 | Evaluation and marketing promotion ↓ | Promotion and Marketing | |
| | | | |
| Week 12 | | Evaluation of the project | |
| | | Students' final assessment of their task as they reflected on their finish task | |
| Week 13 | | Final presentation | |
| | | Presentation of the completed tasks | |
| Week 14 | | | |

Timmy planned his programme of work to be covered in 13 weeks of the second semester of 2006. Although Timmy decided to stick with the six weeks as given in the example format, he was the only teacher who had decided to add extra activities under the design phase of the design process (investigation, design, and devising). The activities included identifying the key learning areas, identifying the context, developing design brief and specifications, investigating ideas from stakeholders, visiting industries, developing initial ideas using 2D and 3D technical drawings, learning basic computer skills, investigating and researching more ideas, reassessing and evaluating the initial design idea or concepts, and learning about the computer software programmes to be used for designing their technology tasks. Under the construction phase of the design process, he planned his activities into four weeks, which included tasks of designing initial ideas on the computers, inserting photos, printing, and setting layouts on computers. The evaluation phase was planned to be

covered in three weeks, and while he decided to use the same activities as given in the example lesson plan format, he at least gave some details of the activities to be done during the evaluation and marketing promotion phase. The sequence of the activities outlined in Timmy's lesson was intended for both tasks.

Summary of the teachers' technology lesson planning

In examining the teachers' technology lesson plans and the teachers' programme of work, certain things were similar. As all the teachers were using the same lesson plan format, all lesson plans were organised in a similar fashion. The teachers' lesson plans were organised under task definition, generic learning outcomes stated as overall dimensions of technology and specific learning outcomes, outlined under four learning domains: conceptual, procedural, technical and societal. The teachers' programmes of work which outlined the teaching lessons in sequences were organised into weeks, three phases of the design process, and activities.

Although the teachers' task definitions varied, some teachers had similar task definitions. For example, Zebedee and Ronald's task was to design and construct a stool to be used at school. Raymond and Anthony's task was to design and construct a coconut scraper. The other three teachers, Gilson, Richard, and Timmy had different task definitions. Gilson's task was to design and construct a range of electronic devices for different uses. Richard's task was to design and construct a safety box to keep personal items securely and safe. Unlike the other teachers, Timmy had two task definitions for his Form Two technology class. His first task was to design and construct 2007 calendars to be sold as school souvenirs to students leaving school, and second was to design a soap package to be used for the soap bars made at the school by the Form One science class. Except for Timmy, who decided to do something totally new, the teachers selected tasks that they already planned to teach in semester two of 2006.

In examining the teachers learning outcomes, there were also some similarities. For example, "understanding strength and balance" was the most stated learning outcome under conceptual. Another similar learning outcome was "different people have different preferences" under the societal learning outcome. These learning outcomes were similar to those given in the example lesson plan (see Figure 6.2). Under the

procedural learning outcomes, most were based on the design process procedures. Under the technical learning outcomes, most were based on the technical drawing skills and manual skills required for using hand tools. The teachers had little difficulty identify procedural and technical learning outcomes.

As in the teachers' lesson plans, similarities were also noticed in the teachers' programmes of work. Almost every teacher used the activities under the investigating, designing, and devising phase, as well as activities under the evaluation and marketing promotion phase, as they appeared in the example programme of work (see Figure 6.3). Timmy was an exception. He reorganised his activities under the design phase with additional activities and had activity details outlined under the evaluation phase. The teachers' timing of their programmes of work ranged from 13 weeks to 16 weeks of the second semester of 2006. Three teachers planned to cover their programmes of work in 13 weeks, other two teachers planned for 15 weeks, and another two teachers planned to cover their programmes of work in 16 weeks. The number of classes each teacher had in a week varied from school to school. Some teachers undertook their technology twice every week, while a few teachers were able to see their classes three times every week.

7.3.2 Teachers' Changed of Teaching Approaches

The PD programme also impacted on teachers' teaching approaches in 2006. In 2006 teachers' depended less on prescribed documents, employed a design process focused teaching approach, used more open ended tasks, used context-based tasks, integrated theoretical and practical lessons, and used community involvement based student tasks.

Teachers' depended less on prescribed MoE documents (Textbooks)

The PD programme enhanced the teachers' confidence to teach without the use of the prescribed MoE curriculum documents as in 2005. The Industrial Arts / Design and Technology syllabus and the teacher and student textbooks produced by the Ministry of Education are referred to as the MoE curriculum documents. Teachers depended on these for teaching in 2005. The PD programme helped the teachers to undertake a new teaching approach where the teachers identified the technology tasks for their students and planned their own technology lessons based on the identified tasks rather than

relying on the prescribed lessons from the MoE textbooks as the only teaching resource (Section 5.2.2). As Richard explained:

With the new [teaching] approach I don't need to rely on the syllabus and also the curriculum produced textbooks to teach from. (22/8/06)

Timmy also reiterated this view and pointed out that a total dependence on the MoE prescribed documents was seen to be unnecessary, as the teachers' task was to seek other relevant resources related to the students' tasks. He stated:

When we identify our own tasks, we don't really need the content in the syllabus and textbooks, because our content is going to be picked from the task. So what we might need to look for are other resource books that have the relevant notes related to the tasks. (9/9/06)

This similar view was also highlighted by Zebedee as he pointed out the implication of the new teaching pedagogy. He reiterated that the new teaching approach lead teachers away from depending so heavily on MoE prescribed documents:

This new [teaching] approach has implied that we need to depend less on the syllabus and textbooks that we used to teach from. (28/7/06)

An understanding of the new teaching pedagogy helped these three teachers to think differently about the use of the MoE prescribed documents when teaching technology lessons. It also encouraged teachers to think of depending less on the MoE prescribed syllabus and textbooks as the only resource materials for technology lessons. This indicated an important shift of view which was in contrast to the total dependence on MoE prescribed teaching materials in 2005.

Design process focused teaching approach

The use of the design process teaching approach made teaching more interesting to teachers and also made learning exciting for students. Although only four teachers - Zebedee, Anthony, Ronald, and Timmy - showed evidence of embracing the whole design process teaching approach focus, all six teachers who managed to undertake their technology tasks during the PD programme talked about the excitement they experienced when they undertook the design process teaching approach. For example, Raymond found that the use of this approach motivated his students to be active learners when undertaking their technology tasks, which he also found very interesting. He commented:

I've tried the design [process teaching approach] with my lower forms, the Form Ones, and I found it very interesting and exciting. This approach really motivated the students to work actively on their task. (24/7/06)

Ronald compared the design process teaching approach with his previous prescribed MoE textbook teaching approach. He pointed out that the prescribed MoE textbook teaching approach only encouraged students to do as prescribed. In contrast, the approach based on the new technology curriculum really encouraged students to think for themselves.

The teaching approaches teachers used when teaching the old syllabus is kind of encouraging teachers to do more spoon-feeding kind of teaching rather than encouraging students to think for themselves. This is what the design approach in the new [technology] syllabus is all about. (27/7/06)

Timmy agreed that the design process teaching approach involved students in thinking for themselves. He added that as students learn to do things themselves, the teacher's job is to assist them and to work alongside them.

The new approach is a good idea in the sense that it gets students to think for themselves. It also gets students involved in doing things themselves. The teacher is just there to guide the students and to move them along as they progress. (15/8/06)

Of these four teachers, Richard and Timmy saw the design process not as a linear process, but rather an iterative process. Both teachers talked about the process they followed when undertaking their technology tasks:

We did not quite follow the linear procedure of the design process but we worked back and forth through the procedures outlined in the design process. After we identified the task then we worked on developing the initial ideas before moving on to list the required specifications - working iteratively helps us see how the whole task is related. (Richard, 28/7/06)

We didn't quite follow the design approach but we did our investigation first before we worked out the specifications required. We considered the design process as an iterative process, which means you can start anywhere. In our case, we did not start at the beginning of the process by identifying a problem first, but we started from the end of the process by firstly evaluating an existing product and worked upward. Sometimes we even worked back and forth within the design process. So I think the iterative approach of the design process is a natural approach in doing a design task. (Timmy, 4/8/06)

Zebedee also talked about the design process teaching approach as an interesting teaching approach. This approach gave his students the opportunity to engage in

designing and making a product of their choice, taking into account that their parents would be their target market. He commented:

I've tried the design [process teaching] approach with my Form Two and found it very interesting. The students identified the types of products to be constructed, which they could sell during the school's open day to be held in five weeks time. Their target market is their parents who will be visiting their school on that day. The products that were identified are now being constructed by students during their technology classes. (8/8/06)

These teachers talked about the design process-based teaching approach as an approach which encouraged students to become active learners. This was in contrast to 2005 when students' tasks were closed and prescribed, and teacher direction was the main teaching approach.

Open-ended tasks

Although all seven teachers outlined open ended tasks in their lesson plans, only four of the teachers - Anthony, Ronald, Zebedee, and Timmy - embraced the idea of teaching technology using open-ended tasks. This approach was in contrast to the teachers' previous closed task teaching approaches in 2005 (see section 5.3.2). The other three teachers encountered difficulties in implementing open-ended tasks. These difficulties are discussed later in this chapter. With the design process teaching approach, the students were given the opportunity to design their own products as possible solutions, addressing the identified problems or needs. The nature of this process saw students undertaking open-ended tasks as they worked within specific contexts. For example, in Zebedee's (unobserved) Form Two class, his students were asked to identify a product that they could make and sell to their parents during their upcoming school Open Day. The tasks were open as students were given the freedom to identify any product that their parents might need and could buy during their school's Open Day. The products shown in the photo in Figure 7.7 are some of Zebedee's Form Two students' work.

Figure 7.7
Some of Zebedee's Form Two students' products



Unlike his students' task in 2005 where all the students were asked to make a rebate joint, his students in 2006 performed a variety of tasks. As shown in Figure 7.7, the products they made were a coconut scraper, a fish scale scraper, wooden spoons, and a wooden roller.

In another (unobserved) class, Anthony asked his students to undertake an open-ended, problem solving based task, where students were to identify a solution for the rubbish problem in the boys' dormitory. He then asked his students to come up with ideas for suitable materials for making a dust brush. The artefacts of the students' task are shown in Figure 7.8: Anthony's Form Five students' final dust brushes and a pan.

Figure 7.8
Photo of Anthony's Form Five students' dust brushes and a pan



The photo shows that the brush on the right next to the dust pan was made of a specific type of grass straw, the one in the middle was made of nylon string from the shop (the sort also used for fishing), and the one on the left was made from coconut

husk fibres. Each student had chosen the materials that they thought would be best for a dust pan brush. This was in contrast to 2005, where the students' artefacts looked exactly the same and students were not given the opportunity to design their own artefacts.

Timmy also asked his students to undertake an open ended, problem solving task. Instead of giving an individual task to everyone, he divided his students into three groups. One of the groups was asked to design a package cover for soap bars manufactured by the Form One science students, and the other two groups were asked to design a school calendar to be used for souvenir gifts to students leaving at the end of the year. The following photos shown in Figure 7.9: are the artefacts made by the students from two of the three groups in Timmy's Form Two class.

Figure 7.9
Timmy's Form Two students' group artefacts



The first photo on the left is the design for the cover for the soap package. The package was labeled with the name of the soap, the ingredients used, and had a colourful background. The photo on the right is the design for one school calendar. The calendar has a photo of the outgoing students and the school campus in the background. Tasks Timmy gave his students meant that they had the opportunity to design and make their own products. This was in contrast to 2005 where the students' task was based on prescribed lessons in MoE produced textbooks. More about students' open-tasks in Timmy's class is discussed in Chapter Eight.

By undertaking open-ended tasks the students were given the opportunity to design their own products as solutions to address problems, or meet specific needs. The range of technology products designed and made by students reflected the uniqueness of each student's individual response to developing the artefacts.

Context based tasks

Another emerging change to the teachers' classroom practices, as an impact of the PD programme in 2006, was the view of basing tasks in context. The two main contexts highlighted by teachers were school-based contexts and community-based contexts. Ronald explained that his students' technology task was focused on the school context.

Our class work is geared towards meeting the needs of the school; for example, dining hall, dormitories, and classrooms. (27/8/06)

The use of the school context was reiterated by Raymond. He noted that his students easily understood the concepts of problem solving when he used school problems familiar to students. He said:

As I talked to the students about problem solving tasks I used our school problems, like the lack of stools and desks for our classrooms, and the students seemed to understand it quite easily. (26/10/06)

Zebedee also pointed out that his students' task was based on the school context because the students' task was focused on addressing a school need. He commented:

My students' task was based on the school context. The problem that we have tried to solve, or the need to be addressed, was the seats needed for the new school science laboratory. So when the problem was given to the students with my guidance, a stool was then decided as the most appropriate form of seat to be used in the science laboratory. (27/8/06)

Similarly, Anthony's technology task was focused on the school context. He asked the students to look at existing coconut scrapers and design one to be used by the Home Science department at his school.

The head of the Home Science department at our school had requested the Technology department to make three coconut scrapers for her department. So I've asked the students to use this opportunity to look at existing coconut scrapers and design new ones for them. (17/8/06)

Richard also took into account the school context which was the students' dormitory, a home at school for students, when undertaking their technology task.

A situation was given to the students where they were asked to think of an item that could be used to keep their personal valuable items safe from burglars in their dormitory, or even at home. From their discussion we have come up with this little box as a solution to this issue or problem. (26/10/06)

Timmy organised his students into three groups. One group's technology task was based on the community context while the other two groups' technology tasks were based on the school context. As he commented:

Two groups looked at the school context and the third group looked at the community context. The two groups' tasks based on the school context were designing a school calendar and the third group's task, which was based on the community context, was to design a package for the soap manufactured by Form One science students. (27/8/06)

These six teachers talked about the contexts in which their technology tasks were undertaken. Interestingly, the school context tasks were dominant. This suggested that teachers selected contexts with which they were most familiar. However, siting a technology task in context was an emerging change. This was in contrast to 2005 where teacher's teaching approaches were very much textbook oriented, teacher dominated, and had no context identified at all.

Integration of theoretical and practical lessons

The professional development programme impacted positively on the fragmented teaching approaches the teachers used in 2005 when they taught theoretical and practical lessons separately (Section 5.3.1). At least three teachers saw the importance of integrating theoretical lessons with practical lessons. Ronald highlighted that the new teaching approach was to be credited with helping him see the importance of merging theoretical and practical lessons. He commented:

The new approach helped me to take into account the balance between knowing and doing rather than separating the knowing and the doing. The theoretical lesson fell well within the time students needed it, in order to do their task. (24/07/06)

This view was reiterated by Zebedee who pointed out the importance of slotting theoretical lessons in at the right time to assist the students with the practical tasks at hand. He said:

The new teaching approach helped me a lot to see where and when I will slot in a theoretical lesson to assist the students with their practical work. (27/8/06)

The teachers began to see that theoretical lessons should not be taught in isolation from the practical tasks, but rather be integrated in a timely manner to assist students with the practical task at hand. Raymond reiterated that integrating theoretical lessons with practical tasks saved a lot of time in terms of getting the technology task done within the given time period.

With the old approach, I kind of taught the theory bits first before I actually started the design process or approach. But with this new approach the theory lessons are integrated into the design approach which does not take up much of the class and teaching time, which contributes significantly to saving a lot of class time. This approach works well for me, as when I get to a certain stage of the project I then slot in a theoretical lesson which is relevant to the timing of the students to be able to get on with the next stage of their practical project. So with this approach, it keeps the progressive work flowing and I found that it is very easy to follow. And because this approach saves a lot of time, I also think that the tasks the students are working on will also be completed on time as well. (27/8/06)

All three teachers saw the integration of theoretical and practical lessons as a way to connect knowing and doing, helpful for moving students forward, and also as a way to save time in teaching and learning. This pedagogical approach in merging theoretical lessons with practical lessons was in contrast to the isolated teaching of theoretical and practical lessons which these teachers used in 2005.

Community involvement based student tasks

Three of the teachers - Timmy, Zebedee, and Anthony - asked their students to involve the community when they were undertaking their technology tasks. The students were asked to collect information from the people in the community. The teachers moved away from the use of textbooks as their usual source of information, teacher-dominated teaching approaches, and also classroom confined lessons (Section 5.3.3). For example, Timmy asked his students to visit a number of industries in the city to collect information to assist them with their task of designing a soap package. He commented:

I sent my students down to visit the industries in the city, such as the soap factory, the printing press, such as Keen Signs. I did this basically to get the students to get some basic ideas from these industries on the type of products they are working with in their class activities. The students were sent every Friday for three weeks to have a look at the range of different materials available in town and get their costing. (27/8/06)

Zebedee pointed out that his students' task involved the teaching staff of the school. He explained that he sent his students with written questionnaires to investigate the needs of the teaching staff in the staffroom.

With my Form Two students I gave them some questions to ask the teaching staff at the school, as they investigated the needs of the staff in the staffroom. After the investigation, they found that the teaching staff needed bookshelves. The bookshelves would provide a place for the teachers to store their books and keep their desks tidy. (27/8/06)

Similarly, Anthony involved his students in the school community. He asked his students to seek information on the design of the coconut scraper from the users of a product, the head of the Home Science department at the school and her students.

I asked the students to interview the users of the coconut scrapers in order to get some ideas on how they would like the coconut scrapers to be designed. (17/8/06)

These three teachers asked their students to involve people in the community. This involvement with the community was mainly for collecting relevant information to assist the students with their technology tasks. Rather than confining all teaching to the boundaries of the classroom as they had in 2005, the teachers' practices in 2006 extended students' participation and learning beyond the four walls of the classrooms into the community.

7.3.3 Teachers' Enhanced Assessment Practices

The teachers' assessment practices in 2006 also showed changes. The teachers' formative interactions changed from one-sided teacher-student conversations in 2005 to reciprocal teacher-student conversations. Also the teachers' summative assessment criteria in 2006 were extended to include the design criteria in addition to the traditional test, homework assignments and technical skills criteria in 2005. The changes to teaching pedagogies fostered reciprocal teacher-student conversations and the inclusion of the design criteria for assessment by most teachers. The details of both forms of assessment are discussed next in detail.

Evidences of enhanced formative interactions

The teachers' changes to teaching pedagogies impacted on their formative interactions in 2006. There was evidence of reciprocal teacher-student conversations in 2006,

instead of the previous one-sided or teacher-dominated conversations of 2005 (see section 5.3.4). As students took up a more active role when undertaking their technology tasks, they talked more openly and freely about the tasks they were doing, the processes undertaken during the tasks, and their responses became more extensive. For example, Timmy's conversation with his students showed that the students were willing to share with their teacher what they had discovered from their visit to the soap factory.

Timmy: What did you find from your visit to the soap industry?

Jackson: We found out the range of soap they manufactured.

Timmy: Did you find anything to do with the cover packaging?

Kenton: Yes, they told us that the packaging they used for their soap were made and printed overseas.

Samuel: The materials used for the packaging of their soap are made of special papers that are able to withstand water.

Timmy: Don't they have any blank papers without print that we could buy?

Kenton: No, they don't have blank papers, only printed papers.

Jackson: But teacher, they have suggested to us that we could get some strong papers from the bookshop, which also has similar qualities as the paper they are using.

Abel: Yes, teacher and we can take it down to the Keen Sign to be printed.

Timmy: OK. That's good and I'm really glad to hear about the information that you have gathered from your visit to the soap factory. It has given me some ideas on what we need to do next.

In his teacher-student conversations Timmy's questions were set up as a form of diagnostic questioning to help students give more information about what they had gathered and learnt from their visit to the soap factory. The shared information was important to Timmy for the development of future planning. Timmy's interaction with his students also revealed that he himself was also a learner, as evident in his question. 'Don't they have any blank papers without print that we could buy?'

Reciprocal teacher-student conversations were also evident in Zebedee's class, as he and Seth (his student) talked about the procedures needed for using the welding machine. In response to Seth's questions, Zebedee used questioning techniques as a way to move Seth's work forward. The following is Zebedee and Seth's excerpt:

Seth: Teacher, can you show me how to use the welding machine?

Zebedee: What did your notes say about what to do first?

Seth: Set up the piece of metal to be welded in position.

Zebedee: And have you done that yet?

Seth: Yes, it's all ready to go.

Zebedee: Then what do you need to do next?

Seth: I think the next thing is to attach the welding machine clamp on the metal that I'm working.

Zebedee: Okay, go on and do that.

Seth: [Seth silently hooked up the welding machine clamp on to the metal to be welded on]

Zebedee: Then, what next?

Seth: Strike the electrode lightly on the metal to start the arc.

Zebedee: That is right, so try it.

Seth: I have tried it but it didn't work.

Zebedee: Try it again and let's see how you do it.

Seth: [Silently Seth struck the electrode on the metal again and again]

Zebedee: You need to apply a bit more pressure when you strike the electrode on the metal.

Seth: [After several attempts, he managed to ignite the welding rod]

Zebedee's conversation with Seth was aimed at getting Seth to identify the process of using a welding machine. The teacher-student interaction got the student to participate in a task as he responded to the teacher's questions. It was a process of self checking to see if Seth had understood the welding procedures. Encouragement by Zebedee assisted Seth to try again and finally succeed. This is in contrast to 2005 where Zebedee directly instructed his students to do exactly as they were told.

A similar reciprocal teacher-student conversation was evident in Gilson's class. The teacher-student conversation was a two-way conversation, as Gilson and Fred (the student) talked about problems with an electronic circuit. Gilson used a questioning technique to help his students think about the problem they were trying to solve. The following is an excerpt of their conversation:

Fred: Excuse me teacher, my project is not working. Can you come and check it?

Gilson: [teacher walks over] Okay, have you checked your connections?

Fred: Yes, I did.

Gilson: Are the screws fastened nicely and tight?

Fred: Yes, I think so.

Gilson: Okay, are your transistors connected the right way?

Fred: Well, you check it.

Gilson: It looks good. Can you try it again?

Fred: It still doesn't work.

Gilson: Then what do you think is the problem?

Fred: There might be a problem with the components, or one of the components might not work.

Gilson: I don't think so because they were all tested before and all the components were working.

Fred: Maybe the battery is flat.

Gilson: Okay, let's try another battery to see if the problem is with the battery.

*Fred: [Fred removed the battery and attached a new battery and it did work]
Now we solved the problem.*

In the conversation, Gilson responded to Fred's questions, as he got stuck with his electronic circuit. Gilson provided Fred with a checklist to undertake and test out. The teacher-student interaction showed that both the teacher and student were involved in making suggestions on what they thought the problem was with the electronic circuit. This was in contrast to teacher-student interactions in Gilson's class in 2005 where students were only asked to give the one right answer (see section 5.3.4).

Teacher's questions were more inquiry type questions and the students responses were not only extensive, but also informative. The conversations led teachers to provide directions and instructions to students and, in response, students were involved in participation as they undertook their technology tasks. The teachers' formative assessment practices changed to being more interactive and progressive. In other words, the teacher-student conversations were more reciprocal with teachers and students prepared to discuss ideas together. Teacher sought input from students and valued their ideas, and students had the confidence to express their ideas. This is in contrast to the teacher-student interactions in 2005 where teacher-student conversations were very much one-sided and non-reciprocal.

Evidences of teachers' broader summative assessments

Teachers' summative assessments criteria outlined in this section were written separately from their lesson plans in their own time at their schools. Not all teachers revealed their summative assessment plans to the researcher. However, the teachers who shared their summative assessment criteria with the researcher had the design aspect as additional criteria in the summative assessment. Two teachers, Ronald and Anthony, planned to use the Ministry of Education assessment format to summatively assess their students' work (see Figure 7.10). The MoE Assessment Format is normally used for assessing students who have undertaken a practical project in Design and Technology towards a Form Five school certificate.

Figure 7.10
MoE assessment format

Design and Technology Practical Project Assessment

School.....
 Teacher.....
 Date.....

| Family name | First Name | Design Folio 50% | Construction phase – 50% | | | | | | | | | |
|-------------|------------|---------------------|--------------------------|----|----|---------------------|-----|-----|------|----------|--------|-------|
| | | | Joints | | | Accurate dimensions | | | | Hardware | Finish | Total |
| | | | 20 | 20 | 20 | L 5 | W 5 | H 5 | SQ 5 | 10 | 10 | 100 |
| | | | | | | | | | | | | |
| | | | | | | | | | | | | |
| | | | | | | | | | | | | |
| | | | | | | | | | | | | |
| | | | | | | | | | | | | |
| | | | | | | | | | | | | |
| | | | | | | | | | | | | |
| | | | | | | | | | | | | |
| | | | | | | | | | | | | |
| | | | | | | | | | | | | |
| | | | | | | | | | | | | |
| | | | | | | | | | | | | |
| | | | | | | | | | | | | |
| | | | | | | | | | | | | |
| | | | | | | | | | | | | |
| | | | | | | | | | | | | |
| | | | | | | | | | | | | |

The assessment criteria consisted of a design folio and the construction skills. The construction skills covered the joint constructions, the accurate dimensions, fitting of hardware and the finishing skills. Each criterion had either a mark or a percentage given. The design folio is an additional assessment method not used by these two teachers in 2005.

However, Zebedee and Timmy decided to use new assessment criteria for summative assessment of their students’ technology tasks. The assessment criteria shown in Figure 7.11 were the criteria Zebedee used for assessing his students technology tasks.

Figure 7.12
Timmy's project assessment criteria

| Marking Criteria | | | | | |
|---|-------------|-------------|------------------|------------------|-----------------|
| Making Criteria | Poor | Good | Very Good | Excellent | Total |
| Conceptual - design principles - use of colours | | | | | 20 marks |
| Procedural - design folio | | | | | 40 marks |
| Technical - design graphics - use of camera - use of computer | | | | | 25 marks |
| Societal - discussion of potential markets - presentation | | | | | 15 marks |
| | | | | | |

As shown in Figure 7.12 Timmy organised his summative assessment criteria under conceptual, procedural, technical, and societal categories. Marks were awarded for the achievement of the learning outcomes under these four domains. In Timmy's assessment approach he took into account not only the assessment of the final product but also the processes involved in the achievement of the final product. These were the development of conceptual understanding, the procedures undertaken during the process of finding a solution, the skills learnt and applied in constructing the product, and the involvement of community participants. His assessment approach focused on the learning outcomes outlined in his lesson plan.

Teachers' summative assessment practices were much broader than in 2005, as they were based on a wider range of activities. Almost all the assessment criteria used by the teachers included the assessment of the design folio in their summative assessment criteria. This was in contrast to summative assessment in 2005, where teachers' summative assessments criteria were not clearly revealed to the researcher, were limited to only a few activities, and did not include design process.

7.4 Effects of Teachers' Change of Teaching Practices

This section discusses the effects of the teachers' enhanced teaching practices. Section 7.4.1 discusses the teachers' enthusiasm in using the new teaching approach with other classes, and their enthusiasm to continue with the design process teaching approach in future is discussed in section 7.4.2.

7.4.1 Teaching Using the Design Process Teaching Approach with Other Classes

The effects of the teachers' changed teaching practices gave them the confidence to try the design process teaching approach with other classes. During the classroom practice sessions, the teachers were asked to pick a class in which to trial the ideas learnt during the workshops. Each teacher's selected class was observed by the researcher during teaching sessions. Although the teachers picked a class for the researcher to observe during a classroom practice session, three teachers, Raymond, Zebedee, and Anthony, decided to also try some of the new ideas in other classes. These classes were not observed by the researcher, as they were the teachers' initiative. As Raymond commented in workshop two:

I've tried out this teaching approach on two classes, one is the Form One class and the other is the Form Five class. Although I've picked the Form Five class for David (Researcher) to observe, I've felt that I must also try it out with my Form One class, because the Form Five students will just finish off early and I may not be able to see the full impact of this approach in the classroom. (27/8/06)

Similarly, Zebedee tried the new teaching approach with another class, as he said in workshop two:

I'm new to this kind of teaching approach so I'm interested in trying it out with various classes. Currently I'm picking the Form Four class and the Form Two class to try out some of these ideas. However, it was my Form Four class that I've asked Mr. Sade (Researcher) to come and observe. (27/8/06)

Anthony also tried the design process teaching approach in two different classes. However, Anthony invited the researcher to observe his Form Four class only. He was positive about the impact the new teaching approach had on students in both classes.

David (Researcher) already knows what I have done in class with my Form Four students when he came around to our schools to visit us. But I've also tried the design approach with my Form Five students which I did not ask him to come and observe. I've selected these classes because I'd like to see what impact the new teaching approach has on students at different levels. The impact was really unbelievable as it motivated my students in both Forms Four and Five so much that almost every student had expressed how this subject has helped them to do things which they had never thought of before. (26/10/06)

7.4.2 Teachers' Decision to Continue with the Design Process Teaching Approach

Of the seven teacher participants in 2006, four indicated that they were keen to continue with the design process teaching approach after the PD intervention programme was over. Their experiences developed their confidence and enthusiasm to continue with the design process teaching approach in future teaching programmes. For example, Richard stated:

Now that I'm confident and comfortable with this new [design process] teaching approach, I'll continue to use it in my other classes for my programme next year. (3/10/06)

Richard further reiterated that he was really keen to continue with the design process teaching approach for a while because of increased student motivation and easier teaching, even if the Curriculum Department of the Ministry of Education made changes to the teaching approach in technology education.

Even if the MoE later decide to change the approach to teaching this subject, I would not like to change my teaching approach. I will still stick to this design [process teaching] approach because I found it has made my teaching much easier and it also motivates students in their learning. (3/10/06)

Similarly, Zebedee stated that because he was keen on the design process teaching approach he did not think that he would like to return to the old textbook prescribed teaching approach. He commented:

This [design process teaching] approach has kept me active and I find it very interesting. Now I don't like the previous [prescribed textbook based teaching] approach and I don't think I'll ever go back to that old [teaching] approach again. (23/8/06)

Timmy pointed out that he would repeat the same technology task again the following year so that he could be fully confident with the use of the design process teaching approach.

I am going to try this idea and the same project again next year. I do really like to fully understand how it works so that I can also gain confidence with this new [design process teaching] approach. (4/8/06)

Though Gilson was pressured by external examination requirements to continue with his traditional teaching approaches, he indicated that he would try out the new ideas in the following year.

But I hope by next year I should be able to try out this new teaching approach that we have learnt during our workshops this year, as well as giving students the opportunity to try and design their own. (26/10/06)

These four teachers decided that the design approach was worthwhile continuing within 2007 and beyond.

7.5 Factors Hindering the Development of Teachers' Teaching Practices

Five of the teachers who trialed the design process teaching approach as a change to their traditional teaching practices talked about the difficulties they encountered. These included the need for mass production of their classroom technology products, time limits, lack of materials and equipment and money, school-based assessment and external examinations. These are discussed.

7.5.1 Need for Uniformity of the Project to be Mass-Produced

The need for a uniform product for mass-production influenced the students' product outcomes. Zebedee talked about the need for a uniformity of products to meet requirements and expectations, as a hindrance to students being able to construct a stool of their choice.

Our project is to make a number of stools to be used in the science laboratory. In this situation, the students did their investigations and their own designs of a stool. However, the final design of the stool, which was to be constructed, was actually decided by the teacher because of the need for uniformity of all the stools. (26/8/06)

A sample of Zebedee's Form Four students' stools is shown in Figure 7.13. Presented are the teacher's design of the stool and several constructed stools which were made according to the teacher's design.

Figure 7.13

Sample of Zebedee's Form Four students' mass produced stools



The photo on the left is the teacher's design of the stool, and the photo on the right shows a sample of four student-constructed stools. Though the students developed individual designs, the teachers' design was chosen for the production of the science laboratory stool and all students then made this design.

7.5.2 Time and Monetary Limits

Three teachers Anthony, Raymond and Richard indicated that time constraints, lack of materials, equipment and tools were difficulties they faced when undertaking the design process teaching approach. Raymond stated that lack of materials and equipment were his main hindrances, and these related to a lack of money.

The main problem with my class is the lack of working materials, tools and some specific notes. Therefore, we don't normally get to the making part of our tasks, due to no resource materials and tools. In this regard, our students only did the designing part which involves the identifying of needs, and the designing of the product. Unfortunately, we cannot actually get to the making part simply because our administrators kept on telling me that there was no money to buy the materials. This has certainly affected the completion of the project on time. (26/10/06)

While Anthony also indicated the similar issue of money, the time involved in undertaking the tasks was his main concern. He commented:

The money part involved with the tasks can be a concern for some principals who operate on tight budgets. For me, the time scheduled for the construction phase was my concern, as it was not long enough to get the task completed. (26/10/06)

The time factor was also a concern for Richard. To short circuit the time constraint, he decided not to allow his students to do their own designs, but to do the design part of the technology task himself.

From the students' discussion we have come up with a little box as a solution to the problem of how to keep little valuable items safe, either at home, or in the dormitory. However, due to time constraints we could not get this task completed. I decided not to give the students much freedom to design their own projects, or even to do their own drawings of this project, even though I am aware that they should be designing their own projects. (26/10/06)

This then, resulted in all the students constructing projects which looked alike as can be seen in the photo in Figure 7.14.

Figure 7.14
Richard's Form Two students' work



7.5.3 School-Based Assessment (SBA) and External Examination Requirements

School based assessment and external examination requirements were also a barrier to teachers' changing their teaching practices. For example, although Gilson knew about the design process teaching approach, he was not able to use it in his teaching practice due to the pressure of school-based assessment and external examination requirements he had to meet for his Form Five students.

Rather than taking on the design process approach, I've actually taken a slightly different approach to doing this project, simply because I was pressured with the School Based Assessment (SBA) requirements for my Form Five this year, as well as with the large number of students that I have in my class. (26/10/06)

Gilson undertook a traditional technical skills teaching approach as his focus was on meeting requirements for SBA and external examination. Hence, his students' artefacts were all the same as shown in Figure 7.15: Photo of Gilson's Form Five students' work.

Figure 7.15
Gilson's Form Five students' work



The photos show one student's work on an electronic circuit as depicted in the MoE produced textbook. The photo on the left shows a student working on his electronic flasher circuit project. The student is connecting the circuit components together by screwing them on to the wooden board. The photo on the right shows the student testing the electronic flasher circuit project and the electronic components: LED, resistors, NPN transistors, a wooden board, screws, and pieces of short wires. All his students undertook the same tasks and made the same electronic circuits

These five teachers acknowledged that there were factors (such as the need for the uniformity of classroom technology tasks, time limits, lack of money to purchase material resources and equipment/tools, and school based assessment and external examination requirements) that influenced their decisions not to implement the whole design process teaching approach during their teaching in 2006.

7.6 Chapter Summary

The 2006 findings revealed that teachers' previously held perceptions of technology and technology education had changed. The teachers' views of technology changed from technology as artefacts, and to making something and applying technical knowledge, to technology as a process used for solving technological problems to meet the needs of society. Technology education as hands on activity technical education and as creative activity education changed to technology education as design problem solving based activities. The teachers' common and changed views of technology and technology education showed that teachers moved away from their limited range of previously held views of technology and technology education.

The PD programme impacted on teachers' classroom practices in 2006. The 2006 findings showed that every teacher attempted to change some aspects of their classroom practices. These included (a) teachers writing lesson plans with clear learning outcomes, (b) teachers teaching without using the prescribed MoE documents (syllabus and textbooks), (c) teachers integrating theoretical lessons with their practical lessons, and (d) teachers' following an open-ended, problem solving based approach. The teachers' changed teaching approaches included (a) the use of a context-based teaching approach, (b) the consideration of community involvement in student tasks, (c) and the use of a design process teaching approach. The teachers' assessment practices changed as teacher/student formative assessments become more like reciprocal conversations. Summative assessment also broadened to include a wider range of assessment criteria for student assessment.

The effects of the changed teaching practices on teacher decision-making included their trying out the changed teaching practices with additional classes as well as the observed classes, and their decision to continue with their enhanced teaching practices in the years following the research. The factors that hindered teachers were (a) the need for uniformity of a product to be mass produced, (b) time limits, lack of materials, equipment and tools, and (c) school-based assessment and external examination requirements. Teachers' enhanced understandings about the nature of technology and technology education and their changed classroom practices impacted on student learning. Chapter Eight examines the changes to student learning technology education that occurred in 2006.

CHAPTER EIGHT:

IMPACT ON STUDENTS' LEARNING

8.1 Introduction

Chapter Seven presented the findings from data gathered in 2006 related to teachers' changed perceptions of technology education and technology, and the changes they made in classroom practices in technology education. The chapter revealed that teachers' perceptions of technology education and technology became much broader. Their traditional conservative classroom practices in 2005 changed from teacher-dominated and textbook-oriented approaches to a student-centred teaching approach using open ended tasks in 2006. The teachers' lessons became more than just teaching technical skills and included the teaching of conceptual, procedural and societal aspects of learning. Enhancement of assessment practices was also noted, as the previous 2005 teacher-student one-sided interactions become more reciprocal in 2006. Summative assessment criteria were extended in 2006.

This chapter presents the findings related to the impact of these teacher changes on student learning in 2006. Student changes were revealed in the data analysed from student interviews and an analysis of student work. Students' learning experiences in 2006 were less structured and more student-centred. The students' 2006 learning experiences are presented next in section 8.2. Section 8.3 presents a chapter summary.

8.2 Students' New Learning Experiences

This section presents the effects of teachers' changes in teaching practices in 2006 on students' learning in technology. The teachers' classes in 2006 are described in section 8.2.1. This section is followed by students' learning experiences in the classes of six of the teachers: Anthony's class in Section 8.2.2; Timmy's class in Section 8.2.3.; Zebedee's class in section 8.2.4; Ronald's class in section 8.2.5; Gilson's class in section 8.2.6, and finally those in Richard's class in section 8.2.7.

8.2.1 Teachers' Classes selected in 2006

The teachers' classes observed in 2006 were varied. Some teachers selected the same class level taught in 2005 but with new students, and others decided to select a different class level with the same students they taught in 2005. One teacher picked a new class with new students altogether in 2006. Unlike the classes in 2005 which were of mixed gender (see Table: 5.1), classes observed in 2006 were dominated by boys (see Table: 8.1). Jason's and Raymond's classes are not included in the table below (the reasons are outlined below).

Table 8.1:
Overview of teachers' class selections in 2006

| <i>Teachers</i> | <i>Selected Classes</i> | <i>No. of Students</i> | <i>Gender</i> |
|------------------------|--------------------------------|-------------------------------|----------------------|
| Timmy | Form Two | 18 | Boys |
| Ronald | Form Five | 15 | Boys |
| Richard | Form Two | 20 | Boys |
| Anthony | Form Four | 12 | Boys |
| Gilson | Form Five | 20 | Boys |
| Zebedee | Form Four | 12 | Boys |

The class sizes ranged from a class of twelve students to the largest class of twenty students. Student interviews and work were based on the classes taught by six teachers: Anthony, Zebedee, Timmy, Richard, Gilson and Ronald. The two teachers not included were Jason and Raymond. Jason withdrew on medical grounds, while Raymond was not involved with classroom observation due to lack of resource materials, although he attended all three workshops.

The selection of students for interviews, and the collection of students' work for examination was undertaken randomly. The analysis of student interviews and work was undertaken to understand the extent to which the effects of the teachers' changed perceptions and changed classroom practices impacted student learning. Of the six teachers whose classes were observed, five had students working on individual tasks. In contrast, Timmy's students worked at their technology tasks in small groups. Of these six teachers, only four teachers, Anthony, Timmy, Zebedee and Ronald gave their students the opportunity to self-design their technology artefacts. Richard designed the artefacts himself and gave them to his students to construct and Gilson chose an electronic task for his students from the MoE-produced textbooks. Of the

four teachers who had the students designing for themselves, two, Anthony and Timmy, gave their students the opportunity to construct their own artefacts from their design. Zebedee and Ronald had their students construct a teacher-designed artefact, even though the students had created their own designs. The student learning experiences in each of the six classes are discussed next.

8.2.2 Students' Learning Experiences in Anthony's Class

This section presents Anthony's students' learning experiences. In 2005, his students' learning experiences were very structured and textbook-based. However, Anthony's change of teaching practice in his 2006 approach exposed his students to new learning experiences. In 2006, his Form Four students designed a coconut scraper, something his Form Four students did not do in 2005. Students were to design their own coconut scraper and this opportunity to self design was highlighted by students in both their conversations and work. In a conversation with Jim, he talked about the factors he considered when designing such as rigidity, stability and space appropriateness:

In my design of the coconut scraper I have to consider a design which is rigid and stable and must have enough space to take into account a range of different sized coconut shells. (5/10/06)

I had a conversation with Patrick, another student, and he also talked about the design aspects underpinning his coconut scraper. He was able to identify the key problem he was trying to solve. The following is an excerpt of our conversation:

Researcher: Could you tell me about your design?

Patrick: I'm designing a coconut scraper that can be folded so that it can be stored away after it has been used.

Researcher: Why would you like to make a folding coconut scraper?

Patrick: Well, coconut scrapers made on top of stools were favoured by most people because there is a place for the user to sit. However, when it was stored away it took up too much space. So I'm trying to make a coconut scraper on a stool that can be folded after use so it doesn't take up so much space.

Researcher: Do you think it is easy to make it?

Patrick: I think I can make it and I'll also get my teacher to help me. (24/8/06)

As mentioned earlier, Anthony gave his students the opportunity to create their own designs. They had to design and construct a coconut scraper for the Home Science department. Shown in Figure 8.1 is James' design of his coconut scraper, where he considered ergonomic concepts. His design had a piece of metal shaped for scraping

the coconut flesh positioned on one end at the top of a wooden stool. He also considered balance and strength in his design, as his wooden stool had two wide wooden legs attached under the top board to provide balance. Strength was provided by attaching two wide boards to each side of the seat with the wooden legs under the seat.

Figure 8.1
James' design of the coconut scraper

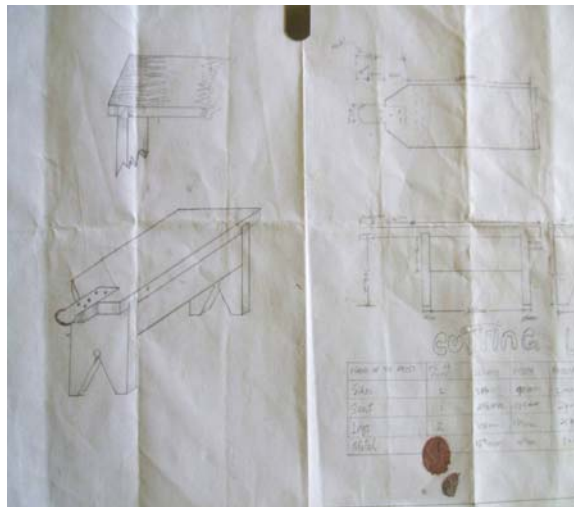

The details of James' coconut scraper design consisted of a pictorial drawing of the coconut scraper at the bottom left, a pictorial detailed joint of the legs and the seat at the top left, an orthographic drawing of the top view on the top right, at the centre right was the side view of the coconut scraper, and finally, the cutting list at the bottom right. James design shows how the design approach activity engaged him in 2D and 3D technical drawings. These enabled him to design his own coconut scraper. Other students in this class also created their own designs. This was in contrast to 2005 where Anthony had designed the artefacts for students to make.

The design approach to teaching that Anthony undertook also encouraged his students to engage in informal group discussions, as they discussed their initial ideas. These discussions created a new learning experience, as students helped each other. This was unlike 2005 where Anthony was the only source of help. One of the students, Edward, talked about having group discussions as a way to get his initial ideas on

track. After the group discussion, he further developed the ideas discussed according to his own preferences. He commented:

I'm designing my own coconut scraper, but when I was stuck with my work, I sometimes asked my classmates for their ideas, but at the end I made the final decision on what I wanted to do next. The discussion was done mainly to get their views only and to help me with some ideas. (6/8/06)

The construction of the coconut scrapers also provided Anthony's students with the opportunity to acquire various skills in both metalworking and woodworking. The skills students acquired in woodworking included the use of marking out tools, like rulers and square; the use of handsaws for cutting timbers to required lengths; and the skills of planing, chiselling, and using hammers for assembling the base of the coconut scraper. They also acquired skills in metalworking such as the use of a hacksaw for cutting metals for the scrapers; shaping and sharpening with hand files; and using screwdrivers for fastening the metal scrapers onto the wooden stools. The hands-on learning experiences helped students develop confidence and competence in using both woodworking and metalworking tools when constructing their coconut scrapers.

Figure 8.2

Anthony's student working on his coconut scraper project



The student shown in Figure 8.2 is marking out an angle on the top part of the coconut scraper. He is using a small piece of timber as a straight edge. Although the hands-on experiences provided students with the similar skills required for woodworking and metalworking, the change was that students were able to construct their own designs. Thus they were provided with some ownership of the technology task.

The design process approach focused on student-centred learning approaches and also provided students with ownership, which Anthony's students never talked about in 2005. The students viewed their input in the technology task as one of ownership and one of being sure of what to do. These views were highlighted by James:

I know what I'm doing because these are my own ideas. I have designed it myself and now I'm constructing it following how I've designed it. The only thing our teacher told us to do is to design and construct a coconut scraper for the Home Science department. But how the coconut scraper design should look is actually our own. Because I have already done my design, it is very easy to follow when it comes to the construction part. (5/10/06)

The students also talked about how they took the initiative for enhancing the progress of their task. In another conversation I had with James, he talked about the working procedures he had undertaken when constructing his coconut scraper. The construction procedure he followed was his own sequence and was different from that of the other students. He started with the most difficult task, before taking on the easier task. He commented:

I've decided to work on the metal part of the coconut scraper first because it is the hardest part to do. Once I have completed that then I can go on to do the base or the legs of the stool for the coconut scraper, which is just an easy part to do. So the [working] procedure which I'm taking is quite different from the other students. I'm following this [working] procedure because I found it much easier and quicker for me, as it is faster to do the easy part later. 5/10/06

The design process teaching approach undertaken by Anthony impacted on his students' learning experiences. His students became engaged in designing and constructing their own technology artefacts, taking into account the aspects underpinning their designs, relating technical drawings to their artefacts, undertaking technical skills related to the artefacts, and taking up self initiatives and ownership of their technology tasks.

8.2.3 Students' Learning Experiences in Timmy's Class

In 2006, Timmy divided his Form Two students into three groups. One group designed and constructed a soap package, while the other two groups designed and constructed calendars. Timmy's change of teaching practices from the textbook-based teaching approach in 2005 to a design task teaching approach in 2006 impacted on his students' learning experiences. He engaged his students in a wider variety of learning activities than any other participant teacher. For example, the additional learning

activities Timmy's students were involved with included students working in groups, students involving the community, and students being given the opportunity to reflect on their design progress during the course of developing their artefacts.

As Timmy's students were used to working on an individual basis, group work was a new experience. The students spoke highly of the advantages they experienced in learning as a group when undertaking their technology task. Some students said that sharing ideas among group members was the best part of group work as everyone contributed these ideas. This view was shared by several students as seen in their comments:

When we work in groups, it is easier because we can share ideas. Although different students came up with different ideas when we did our discussions, we all will come to agree with one idea. (Timothy, 22/8/06)

As every student contributed their views and ideas, the task seems to be easier and we tend to move faster as we share together. (Samson, 19/9/06)

Working in groups makes the work more interesting as it makes you more active as you get involved with the work. In group work we learn from others, like those who know about the computer taught us how to use the computer and how to make our calendar using the computer. (Albert, 22/8/06)

Others said that working in groups was preferable to working alone:

Sharing ideas as a group makes the work easier rather than working as an individual. (Michal, 22/8/06)

We find this task hard when we work as individuals but when we work as a group it is easy as each one will be sharing ideas. (Samuel, 22/8/06)

Working in groups help you to share ideas but when you work individually you will be short of ideas, and it is those shared ideas that contribute to the completion of the project. (Jackson, 22/8/06)

Some of the students realised that group work depended on the cooperation of individual members in the group. As one of the students, Fred, pointed out, cooperation was crucial for getting their work done on time. He added that group work can only work well if every individual member contributed. He said:

In order for this kind of task to be completed on time and to be done properly, cooperation from all group members is very important. Each individual has to play his part in the task in order for the task to be completed on time. (5/10/06)

Timmy's students perceived that group work could help them work faster and more easily. The social element of group work made the work interesting and exciting. Individual ideas and decisions were seen by students as crucial aspects of group work and they were instrumental in the group outcomes. The group work with which Timmy got his students engaged provided his students with new learning experiences which enabled them to learn about the pros and cons of group work.

Timmy's change of teaching approach involved his students in research in the business community, which impacted on their learning experience. Prior to the PD programme, Timmy's students had never experienced learning involving community research, as learning activities were confined to classroom settings. Hence, community research was a new learning experience for his students and provided them with new information from an out-of-school source. For example, one of the student groups that visited the soap factory found new information related to the type of materials used for packaging soaps. Samuel, a student from the group said that their visit enabled them to learn about the paper used for soap packaging:

From our visit to the soap factory, we learnt that the papers used for packaging the soap is not an ordinary paper like what we use for writing in class, but a special paper. The paper used for the soap is like plastic but it's not plastic. I think it's between plastic and paper, because you can write on it but it withstands water. (19/9/06)

The groups who designed a calendar also got involved in community research by seeking extra information and financial help from the business community. As Sam explained:

We gave the big companies in town our letters seeking sponsorship for our calendar project, and their response was good. We selected companies like Telekom, SIEA, Hotels etc., and they asked us to check back after one week for their response to our letter. (5/10/06)

Another student in the same group, Kenton, also talked about another initiative undertaken by his group when developing their calendar. He commented:

Because we wanted to use a photo of the school campus taken from the air so that we can see the whole school campus, we had to find ways to do it. From our discussion we decided that someone should get up in the helicopter and do an aerial shot of the school campus. We were lucky to have someone in the group whose father is working in the Aviation department. So he organised that with his father and he went up in the RAMSI helicopter and got the aerial shot of the

*school campus. So that was the photo used for the background of the calendar.
(5/9/06)*

Using a personal context, the students were able to fulfil their design specifications of including the whole school campus. Samuel talked about using the business community abroad as a way of saving cost and possibly earning money. He commented:

Once this project is completed, we are thinking of paying off the master copy from the publishing company in town who will be printing this calendar for us. We will send it to Fiji, where we think it will be cheaper if we want to print several copies to sell in the Solomon Islands. We are thinking of doing this so that we can get some money for ourselves to pay off our hard work that we put in this project. (5/10/06)

Community participation was viewed by Timmy's students as a positive learning experience. The students' involvement with the wider community brought new learning experiences to them in 2006, and was in contrast to being confined to the traditional classroom setting in 2005.

Timmy was the only teacher who used a full design process approach, so his students undertook the reflection process throughout the design process, which was another new learning experience for them in 2006. Students' reflections were undertaken mainly to analyse stages of the task, to figure out shortfalls, then to make improvements. For example, after the students printed the first design of their calendar, they reflected on its shortfalls and discussed any improvements needed. Shown in Figure 8.3 is the first sample of the calendar designed by one of the student groups.

Figure 8.3
First sample of the students' calendar



The first sample calendar had the name of the school and the year at the top of the page with a sunset background. All 12 months were laid out in the bottom part of the page with the background of an island positioned in portrait layout. The calendar was printed in black and white for evaluation and discussion purposes. Shortfalls and suggested improvements were discussed by the group. As Kenton reported to me:

After we had printed our first copies of the calendar, we all sat together in our group and evaluated it. From our discussion we saw that our first sample did not have the right background because we have used a background which we just picked [up] from the computer. Really we should be using a photo of the school for the background of our calendar. Another thing that we also noticed was that the front page photos were taken from a distance as long range shots. So really we needed to replace them with close-up shots, so that the characters in the photos could be seen more clearly. We hoped that after we sorted these things out we should be able to come up with the final solution. (24/8/06)

The reflection process enabled students to seek alternatives as improvements to their initial designs. Thus, Timmy's students made adjustments to their initial background pictures taken from the Internet and the calendar layout taken from Word publishing software. The shortfalls of the initial design were identified through the reflection process and the groups' recommendations were taken into account as improvements. The adjustments and improvements were evident in the students' next calendar samples, presented in Figure 8.4: Second samples of students' calendar.

Figure 8.4
Second samples of the students' calendar



Both samples changed to include pictures of the school and students. The two sample calendars were in colour and in two different layouts. The one on the left is in a portrait layout and the one on the right is in a landscape layout. The calendar was purposely designed to target school leavers, so the pictures were of the Form Three students (as some of the Form Three students will not continue on to Form Four) and the school campus was photographed and used for the background of calendar.

The reflection process was ongoing with Timmy's students throughout the design process. The students again reviewed the two layouts (the landscape format and the portrait format) to decide which format to use for the final calendar. The following is an excerpt of the conversation I had with Albert and Steven (two members of the group):

Researcher: What is your group discussing?

Albert: We were discussing which layout we [would] like to use for our calendar

Researcher: Has your group decided on which one yet?

Steven: We found it hard to decide because we like both of them.

Albert: We think that this layout [he pointed to the portrait layout] is okay with this current picture, but might not have enough room if we want to include a variety of pictures. This [he pointed to the landscape layout] has space for more pictures. So after we discussed these points, most students agreed that we should use this calendar [he pointed again to the landscape layout]. (22/8/06)

Student reflection was a new learning experience for Timmy's students, as 2005 was mainly textbook-dominated learning. The design process teaching approach enabled his students to experience active learning. They were involved in decision-making for matters involving their learning, and they identified the shortfalls of their initial ideas and designs and made improvements to find the best possible solutions.

The use of the design process approach by Timmy in 2006 was a change of teaching pedagogy for him from his traditional textbook-dominated teaching approach in 2005. The differences experienced by students in learning under both teaching approaches were highlighted in conversations I had with students. The impact of the design process teaching approach on students' learning experiences in 2006 were described by Timmy's students as positive. For example, Jackson commented:

I've learnt a lot more information from this approach than I ever got from the textbook, and I'm also learning faster from this new approach than from the old teaching approach which is based on textbooks. (19/9/06)

Timmy's decision to move away from his previous traditional textbook teaching approach and embrace the design process teaching approach exposed his students to new learning experiences. Thomas, another of his students, pointed out that the new approach to teaching had enabled him to learn new ideas he would not have learnt if the lesson were still based on textbooks. He pointed out that the old teaching approach never exposed students to problem-solving like the new teaching approach did. He commented:

With this task I was able to learn about how to use the computer, which I would not have learnt if we were still following the old approach, which is just based on using the class textbooks. With the old approach we don't learn to solve problems. But with this new approach we are solving real problems, which we have plenty of in our community. (19/9/06)

The nature of the design process teaching approach involved students in designing a product that addressed a particular need or opportunity. The approach offered the students the chance to get the product manufactured and marketed and this was a departure from previous traditional classroom activities. The difference between the two teaching approaches was noted by Kenton:

As we were doing this calendar project, we found this work really worthwhile, as we can see the monetary value in it. This is very different from the other kind of past projects that we usually do as class activities. (5/10/06)

The design process approach Timmy used in teaching technology education impacted on his students' learning experiences in 2006. This view was evident in students' comments as they made reference to the design process approach in comparison with the traditional classroom activities. The design process approach was viewed as a problem-solving approach in real life situations, whereas the traditional classroom activities were viewed as the use of a textbook approach.

Figure 8.5 shows Timmy's students used the computer for designing their calendars and the soap packaging. Most students in Timmy's class had little previous knowledge or experience in using computers. A few students had had access to computers but had limited knowledge and experience. Undertaking their technology task using computers enabled them to acquire both computer know-how and computing skills. The knowledge included starting and closing the computer; understanding the use of general computer icons and specific Word Publisher icons; and the use of the mouse and the keyboard. The students learnt computing skills as they worked through their tasks, and it did not take them long to develop confidence in using computers.

Figure 8.5
Timmy's students using computers



The two groups of students sitting around the two computers in Figure 8.5 were contributing ideas while their group leader was designing their calendar project on the computer. The students were discussing how best to improve their initial designs.

The hands-on learning experience gained by using computers was perceived by students as a new learning experience. For example, Albert pointed out that the use of

This evaluation sheet was used by the group designing the soap package cover. They listed two good points in regard to their soap package design. First, they commented about the rhythms and patterns used on the package design. Second, they commented on the background which was accepted by both the group members and the students who manufactured the soap. The areas needing improvement related to the writing colour and the patterns of the writing on the sides of the package.

The use of the design process in Timmy's teaching approach impacted on his students' learning experiences. They experienced learning in groups, involved the community in their technology tasks, reflected as a group, undertook design activities with a problem solving focus, were involved in hands-on activities, and assessed their own product. These were all new learning approaches for Timmy's students in 2006 and were never experienced by his 2005 students.

8.2.4 Students' Learning Experiences in Zebedee's Class

In 2006, Zebedee's technology task for his Form Four students was to design and construct a stool to be used in the school science laboratory. The use of the design process approach by Zebedee was a new learning experience for his students. For example, Peter, one of his students, stated that this approach to learning was better because their task related to a real life situation. He made comparisons with the previous teaching approach of note-taking either on the blackboard or from the textbooks. He said:

I found this [teaching/learning] approach better than the old approach simply because I have actually dealt with a real task in society. With the old approach I just sit down in the class and copy the notes given to us by the teacher, which is very boring. But with this approach I'm actually working on a real activity, and at the end we will come up with a real product, rather than just taking notes and studying it in preparation for a test, which I think I don't learn much. (19/9/06)

By undertaking the design process teaching approach, students were able to experience many procedural processes. Fred, explained that the technology task helped him to learn about a number of procedural processes, including designing, working from working drawings, and welding skills. He stated:

I've learnt a lot of things from this task of making this metal stool. From the beginning I learnt about the designing of the stool, and then I learnt how to read the working plan and work according to the working plan. I also learn about the use of jigs to keep the work steady when welding. (14/8/06)

Zebedee's students were able to experience the use of design journals or design folios for showcasing the development of their project designs of stools. For example, in Paul's design folio are his sketches of three different stool designs (shown in Figure 8.7: Paul's sketched ideas). Paul's three stool designs included structural design aspects to provide strength and balance to the stool, and a functional purpose with a flat seat placed on top of each structure.

Figure: 8.7
Paul's sketched ideas

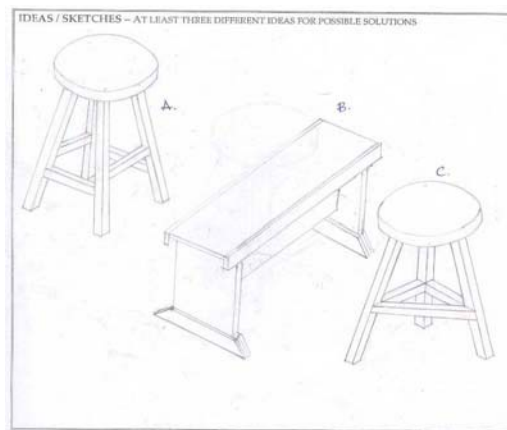

Paul's ideas show design A on the left, with four vertical legs to provide balance and four horizontal rails to brace the four legs for the rigidity of the stool. Although design B only has two vertical legs, wider boards were used to provide balance. To provide strength for the stool, a wider horizontal brace was used at the centre to hold the two legs firmly together with the top board used for the seat, and two boards placed on each side. Design C has three legs arranged and spaced symmetrically also to provide balance, with three rails at the bottom holding the stool legs firmly together to provide rigidity and strength. The stool legs in design A and C were angled out to the base, contributing significantly to the balance. Paul's three design sketches show that he had considered the design aspects of stability and rigidity, which were design requirements seen in Zebedee's conceptual learning outcomes. From the students' range of stool designs they were then to select the most appropriate design for construction. However, Zebedee did not give his students the opportunity to construct their own designs.

As described in Chapter Five, students’ technical drawings did not link with their practical tasks as outlined in the MoE-produced textbooks. In contrast, Zebedee’s students’ technical drawings in 2006 linked with their practical task. The working drawing in Figure 8.8 is Paul’s technical drawing showing an orthographic view of the stool to be constructed for the school science laboratory.

Figure 8.8
Paul’s working drawings

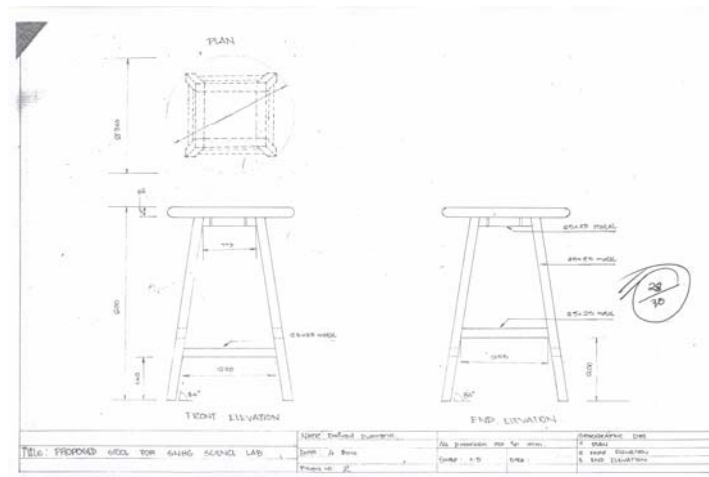

Paul’s technical drawing shows the orthographic view of the stool with the top view on the top left, the side view on the bottom left, and the end view on the bottom right. The drawing also shows the measurement details of various components of the stool. Although, this technical drawing was initiated by Zebedee, as it was Zebedee’s stool design that was to be constructed by the students, the students were still able to relate their construction to the teacher-designed technical drawing.

Zebedee’s students also acquired various skills through their technology task. The students learnt about metalworking skills including the use of marking out tools such as tape measures, squares, and sliding bevels, and, the use of hacksaws to cut metal to the required lengths. The students learnt to use welding machines (see Figure 8.9: A student welding his stool project) as they assembled the base of the stool. They learnt to use grinding machines when they ground down excess weld on the welded base. The hands-on learning experiences helped students to develop competence using a variety of metalworking tools and machines as they constructed their metal stools.

Figure 8.9
A student welding his stool project



In Figure 8.9, Tom is welding the top rail and the stool legs together. This hands-on learning experience helped him to build confidence and competence in using the welding machine.

The students also learnt how to self assess their technology learning. This was a new learning experience, which Zebedee did not undertake with his Form Two students in 2005. To help his students with self assessment he developed a set of questions for his students. The evaluation sheet consisted of seven questions with responses for satisfactory, unsatisfactory and improvements. The things they learned by undertaking this class project were also part of the students' evaluation. See Figure 8.10, Paul's self assessment as an example.

Figure 8.10
Paul's self assessment of his class project

EVALUATION

1. **What is not so good about your job?**
My welding work is not so good
2. **What skills have I learn about this project?**
The skills that I've learnt from this job are; how to weld, how to use the grinding machines, painting, setting out of measurements, cutting metal tubes, shaping and making of the seat etc.
3. **What new information did I learn from this project?**
The new information I learnt was how to weld, measuring and marking out of the materials, cutting, joining, shaping of the seat, and the use of other hand tools.
4. **Could your solution be produced and sold commercially?**
Yes, the stool can be produced and sold commercially
5. **The best things about my project are:**
I learnt a lot of skills and techniques on how to make a metal stool, used other machines, stools and how to do the projects
6. **What would you change about your jobs if you were to make it again?**
I'll change the designs, the metal and the seat and the colour. Improve my painting, moulding, preparation of the seat.
7. **Other comments**
I like making that project, it takes much of my time but it's interesting. It improves my knowledge and understanding, and with that project, I've learnt a lot of skills and techniques.

Paul's assessment of his metal stool project focused mainly on the technical skills of the task. For example, he stated the skill of using the welding machine as an area he would like to improve. He again reiterated the use of the welding machine and other metalworking tools as new information and skills he learnt. He added that the best part of this project was the opportunity to get involved in using these technical tools. Paul's self assessment of his technology task was dominated by the technical learning outcomes.

As Zebedee undertook the design process teaching approach, his students in 2006 were exposed to a number of new learning experiences. These included designing, relating technical drawing to construction and learning new technical skills in metal working, welding in particular.

8.2.5 Students' Learning Experiences in Ronald's Class

Ronald's Form Five students undertook the task of designing a wooden stool to be used in the Industrial Arts workshops as their technology task in 2006. Like the students previously discussed, Ronald's students were given the task of designing their own stools, as a way to solve the stool shortage problem in the Industrial Arts' workshop. Designing is an expected learning experience for the Form Five students throughout the Solomon Islands. Students are expected to sketch at least three different designs and then choose one of the designs to construct as the solution to the problem given. Ronald's students undertook this process. Shown in Figure 8.11 are Samson's three stool designs as his possible solutions for the stool shortage problem in the Industrial Arts workshop. Samson's stool designs took into account the structural design aspects, including strength and balance. The designs also show functional purpose by including a seat on top of each structure.

Figure 8.11
Samson's sketched ideas



Design A (on the top left) has four legs to provide balance for the stool. The stool also has four bottom rails and four top rails bracing the stool legs to provide strength. The legs of stool A are tilted to be wider at the bottom to provide a broad base contributing to the balance of the stool. Design B (on the right) has two wide legs to provide balance and two side rails holding the top and the legs to provide rigidity. Design C is similar to Design A with four legs to provide balance, four rails holding

the bottom legs and four holding the top for strength. However, the legs are not tilted. Samson's three stool designs show that he took into consideration the design aspects of stability, functionality and strength.

An obvious difference between Ronald's class in 2006 and that in 2005 was the use of their technology construction task for their technical drawing exercise. The students' technical drawings were showcased in their design folios. This is unlike 2005, where students' technical drawing exercises were undertaken as an isolated exercise. In 2006, Ronald's students undertook technical drawing of the wooden stool which was their technology construction task. The students' technical drawings consisted of preliminary sketches and working drawings. Shown in Figure 8.12 are Willie's technical drawings of the stool for the Industrial Arts classroom.

Figure 8.12
Willie's preliminary sketch and working drawings

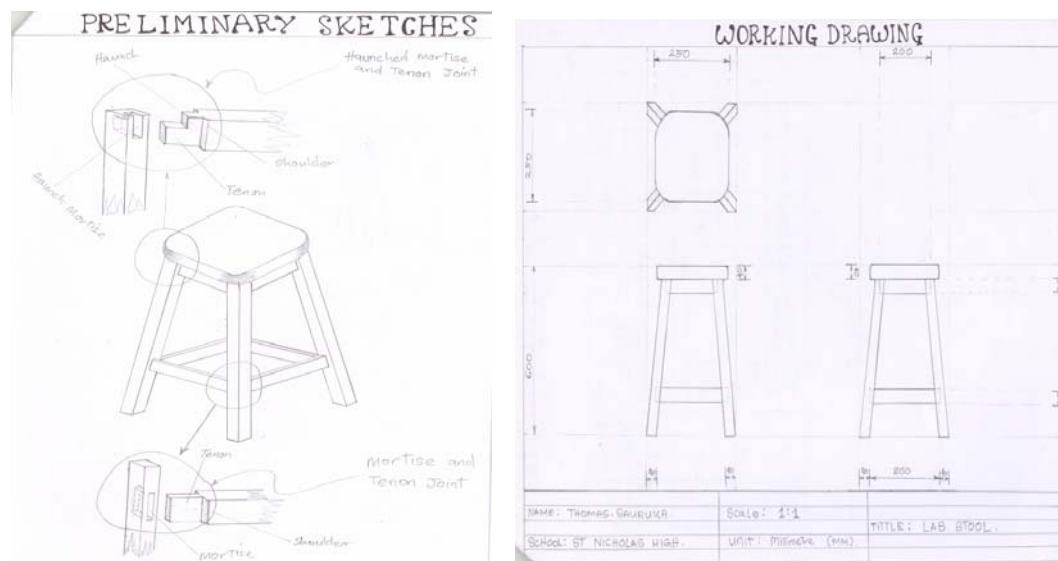

The technical drawing on the left shows a pictorial view of the stool and the details show how the key parts of the stool, such as the rails at the top and bottom, are to be constructed. The details show the selected joints to be used on the rails and the legs of the stools. The type of joints selected provided maximum strength. The technical drawing on the right is a working drawing showing the top, side and end view of the wooden stool. In 2006, Ronald's students undertook more extensive and detailed technical drawings than those in 2005.

As his students moved on to the construction stage of their technology task, they acquired a number of related technical skills. The hands-on skills students learnt matched the technical learning outcomes outlined in Ronald's lesson plans. For example, Figure 8.13 shows two students in Ronald's class using chisels while working on their stool project in the workshop. Apart from acquiring chiselling skills, other woodworking skills were acquired. These include skills such as using marking out tools like the tape measure, marking gauge and try square; using hand planes to plane timbers to the required size; using handsaws to cut timber to the required length, and using electrical drills for drilling the mortise holes. These hands-on learning experiences helped students develop competence in handling woodworking tools as they constructed their wooden stools.

Figure 8.13
Two students working with chisels



Figure 8.13 shows two students in Ronald's class, Philip and Willie, competently using chisels on their stool project. Both students are chiselling off a part of the rail as they made a tenon joint to fit into the mortise already made on the legs of the stool.

Although the self assessment process was to be part of the students' design folios, Ronald's students did not manage to get to self assessing their stools within the time limit of the research. However, the opportunity for students in 2006 for self

assessment of their project was never offered to students in 2005. Therefore, this was to be another emerging learning experience for Ronald's students in 2006.

8.2.6 Students' Learning Experiences in Gilson's Class

Gilson was another teacher who decided to use his Form Four students from 2005, now fifth formers, in 2006. He decided to continue with the technology unit on electronics in 2006 which he started in 2005. However, as he had highlighted in Workshops Two and Three, he did not use the design process teaching approach so his students did not have the opportunity to experience any learning related to the design process approach. Hence, there was no evidence of his students having a design folio for their work. There was no designing undertaken by his students. In fact, the main focus of his students' learning was on understanding the working procedures for how to connect the electronic components in a circuit and to see that the circuit worked. The electronic circuit diagrams given to his students were taken from the MoE-prescribed textbooks, and focused mainly on understanding the functions of the basic electronic components and basic skills for connecting electronic circuits. His students learnt about the functions of the electronic components in 2005 and learnt to connect an electronic circuit in 2006 using a variety of electronic tasks. When undertaking the 2006 task, his students' learning experiences were focused mainly on the technical skills in using screwdrivers to fit screws into the wooden board used as the base for the electron circuit (see Figure 8.14: Two students working on their electronic projects). They also learnt how to use a hand drill as they drilled small holes into the wooden board to facilitate the screwing process. These hands-on learning experiences enabled the students in Gilson's class to develop confidence and competence in using a hand drill and screwdrivers.

Figure 8.14
Two students working on their electronic projects



The two students in Figure 8.14 are connecting their electronic components by following the circuit diagram pasted on the wooden board base. The student in front is using a screwdriver to drive a screw into the wooden base to hold the components in place, and the other student is getting his electronic components out of a plastic bag. Both students were working on getting the electronic components connected in a circuit and checking that it worked.

As Gilson kept to his traditional teaching approach his students did not have the opportunity to grasp the concept of design activities with a problem-solving focus. His students only had limited understanding of the concept of technological problem-solving, as they learnt very little about the design process approach. Here is an excerpt of our conversation:

Researcher: What is the technological problem that you are trying to solve?

Timothy: The technological problem I'm trying to solve is how to get this electronic circuit to work. If it does not work I have to find out why and what is wrong.

Researcher: So really, what is it that you are trying to achieve by making this project?

Timothy: Well, I'm making this project to see that the two lights flash one after another.

Gilson's students were not exposed to the wider learning experiences that the students of the other teachers had experienced, as his students learning experiences were confined to learning about the working procedures and the technical skills required for

undertaking their technology task. Hence, there appeared to be very little difference between his students' learning experiences in 2005 and in 2006.

8.2.7 Students' Learning Experiences in Richard's Classroom

Richard decided to teach another Form Two technology lesson in 2006, with different students from the Form Two students in 2005. His 2006 students constructed several small wooden chests for storing their valuable items in the dormitory, or at home. Although he talked a lot about undertaking the design process teaching approach as well, his technology lesson approach was quite different from the other teachers who allowed their students to design their own solutions to the given technological problems. Richard presented the problem and then discussed possible solutions with his students. After the discussion, he then decided to design a wooden chest himself as the solution outcome and gave it to his students to construct as their technology task. By taking this approach, the main focus of his students' learning was only on technical hands-on learning experiences. In constructing the small wooden boxes, his students acquired various woodworking skills. These included the use of marking out tools such as tape measures and squares, the skill of cutting with the handsaw (see Figure 8.15: A student using the saw to cut plywood to required sizes), the skills of chiselling and planing, and the skills of using hammers for assembling the box and screwdrivers for securing the hinges, hasps and staples. The hands-on learning experiences helped develop students' confidence and competence with using a variety of woodworking tools to construct their small wooden boxes.

Figure 8.15

A student using the saw to cut plywood to required size



Figure 8.15 shows a student using the tenon saw to cut off a piece of plywood as he shaped the base of his wooden box. This student showed confidence and competence in using the tenon saw as he cut through the plywood.

By focusing on hands-on learning experiences as the main factor Richard's students had no learning experiences with designing their own technology task. Furthermore, his students had very little understanding of design process activities, as he was more dominant regarding how his students did their technology tasks. This was evident in a conversation I had with a group of his students as I discussed the purpose and the shortfalls of their technology task. All that they could think of were alternatives focused on the completed project, rather than adjustments to be undertaken during the technology task. Here is an excerpt of our conversation:

Researcher: Why are you making this project?

Tom: Because our teacher told us to make it.

Researcher: What is this box going to be used for?

Isaac: Our teacher said that we could use this box in the dormitory or at home to store small things like necklaces or money.

Researcher: Do you understand what technological problem you are trying to solve by making this wooden box?

Mark: Yes, so that no one could steal our money in the dormitory when we are not there.

Researcher: But the fact that the wooden box is too small, anyone can just pick it up in the dormitory, and hide it away somewhere and you would not be able to see your box and money again. So do you think this small box will really keep your things safe from being stolen in the dormitory?

Isaac: Maybe not.

Mark: But we could lock this small box in our big boxes.

Thomson: Because it's small I'll just carry it in my basket every time I come to class.

The students' learning experiences in Richard's class were limited mainly to technical hands-on learning experiences of construction. They were unable to experience the full extent of design process activities. Therefore, Richard's students' learning experiences in 2005 and 2006 were similar.

8.3 Chapter Summary

The focus of this chapter was on the impact of teacher change on student learning in 2006. The findings indicated that some teacher change impacted on students' learning. Unlike the students' learning experiences in 2005, which were mainly based on

technical hands-on learning experiences, the 2006 students' learning experiences were much broader, and included students becoming active learners. The students commented positively on the changes. They preferred the learning approaches that transformed students' learning in 2006 from traditional passive learning in 2005 based very much on textbook contents and technical hands-on focused activities. In contrast, their 2006 learning changed to active learning and included a range of activities based on the design process approach. The extent to which the students experienced changes to their learning in 2006 varied between teachers, and depended on the extent of changes the individual teachers were willing to undertake in their teaching practices. The teachers who undertook more changes in their teaching practices in 2006 also provided their students with more learning experiences when carrying out their technology tasks. Chapter Nine presents the discussion of this thesis. The changes in teachers' classroom practices in 2006, and the extent to which they impacted students' learning in 2006, are discussed.

CHAPTER NINE:

DISCUSSION

9.1 Introduction

This chapter discusses around the research findings presented in Chapter Four to Eight. This chapter discusses the situations prior to the PD intervention based on research question one, and the impact of the PD on teachers and students, based on research questions three and four. Discussion around research question two is presented in Chapter Ten and focuses on the key characteristics of a PD model that was developed as a result of the research. This PD model is presented as a recommendation for technology education teachers in developing countries and also as the conclusion of the thesis. The first part of this chapter presents the discussion around research question one in section 9.2:

1. What were the teachers' existing views of technology and technology education, and their current classroom practices?

It describes the teachers' narrow views of technology and technology education and the teachers' traditional classroom practices that were presented in Chapters Four and Five. The teachers' existing views of technology were limited to artefact-related perspectives. These views were influenced mainly by the foreign artefacts imported into the country as well as the traditional local artefacts and traditional practices in the Solomon Islands (Sade, 2002). The teachers' existing views of technology education were also limited to hands-on related activities with a technical education focus. These views were influenced mainly by their subject subculture (Jones, 2001; McGee et al., 2002; Northover, 1997), as their teaching backgrounds were technical education. Discussion of the teachers' traditional classroom practices follows next and this focussed on textbook oriented teaching, traditional technical hands-on teaching approaches with teacher-dominated teaching practices, and teachers limited understanding of assessments for learning. Section 9.2 focuses on understanding the teachers' 2005 perceptions of technology and technology education and classroom practices.

The second part of this chapter presents the discussions around research questions three and four in section 9.3:

3. What effect and influence does a professional development programme have on teachers' concepts of technology and technology education, and their classroom practices?
4. What was the impact of teachers' developing understanding and practice in technology education on student learning?

The discussion begins with the impact of the principles underpinning the professional development programme in enhancing teachers' understanding of the nature of technology and technology education and teachers' pedagogical content knowledge in technology education. It describes the impact of the professional development on the teachers' perceptions of technology and technology education, and the impact of the teachers' enhanced understanding of the nature of technology and technology education on their classroom practices. The teachers' enhanced understanding of the nature of technology and technology education, and teaching practices in technology education were achieved through ongoing PD that focussed on social interaction, collaboration and reflection. The teachers' changed views of technology included perceiving technology as a process used for solving technological problems to meet the needs of society while teachers' changed views of technology education focussed on technology education as being design activities with a problem-solving focus. The teachers' changes in their classroom practices included developing their own lesson plans, changed pedagogical practise, and enhanced assessment practices. Section 9.3 also discusses the extent to which the changes to teachers' classroom practices impacted on students' learning experiences. Chapter Nine concludes with a summary.

9.2 Teachers' Limited Understanding of the Nature of Technology and Technology Education and Teachers' Conventional Technical Teaching Practices in 2005

The discussion in this section is based on the first research question:

1. What were the teachers' existing views of technology and technology education, and their current classroom practices?

Technology education in the Solomon Islands has introduced a new era for technical education teachers who are to implement the recently proposed technology curriculum. Therefore, the preliminary part of this study sought to explore teachers' existing views of technology and technology education and classroom practices as these views of participant were likely to impact on how they understand and used the new curriculum. The discussion in

section 9.2.1 is based on the teachers' perceptions of technology and technology education existing at that time. Their traditional classroom practices are discussed in section 9.2.2. The understanding of teachers' perceptions of technology and technology education and classroom practices was important for providing a platform from which to develop and facilitate an appropriate professional development programme to help teachers better implement the proposed technology curriculum as intended for the Solomon Islands.

9.2.1 Teachers' Limited Understanding of Technology and Technology Education

The findings discussed in Chapter Four and Chapter Five revealed that the Solomon Island teacher participants involved in this study had limited understandings of the nature of technology and technology education. These findings (see Chapter Four) were similar to findings in other studies about teachers' perceptions of technology and technology education in the Solomon Islands (Liligeto, 2001; Sade, 2002), and also in other countries such as the UK (Jarvis & Rennie, 1996), Australia (Symington, 1987) and New Zealand (Jones & Carr, 1992). Teachers from various countries with limited understanding of the nature of technology and technology education struggled to come to terms with their respective technology curricula (Anning, 1994; Jarvis & Rennie, 1996; Jones & Carr, 1992; Symington, 1987).

Teachers' artefact-related views of technology

The teachers' existing views of technology were mainly focussed on artefacts. The view teachers held of technology as artefacts, or physical hardware invented or created by human beings, was a common theme revealed in such studies as the work of DeVore (1980), de Vries, (2005), Mitcham (1994), and Wright (1996). A similar view of technology was held by these secondary school teachers in this study as they saw technology as including artefacts both foreign and traditional artefacts in the Solomon Islands. This was similar to the findings of previous studies in the Solomon Islands that examined both the primary and secondary school teachers' perceptions of technology and technology education (Liligeto, 2001; Sade, 2002). The teachers' views of technology as artefacts were mainly dominated by products imported into the country. These may, perhaps, be influenced by the fact that the Solomon Islands is a developing country and most technological artefacts used in the country, such as telephones, computers, cars are mostly common in the urban areas of the Solomon Islands, such as the capital, Honiara, where the study was undertaken. de Vries (2005) states that people's immediate encounter with technology is through technical artefacts. It was also

interesting to note that popular artefacts in the areas of communication and transportation, which were identified in other studies (Jarvis & Rennie, 1996; Jones & Carr, 1992; Symington, 1987), were also identified in this study as teachers talked about their views of technology. Technology being foreign ideas and products was a common theme. Symington's (1987) discussion about teachers' ideas on technology in the primary school curriculum indicates the use of the term technology by the media tends to link it with the more sophisticated, recent industrial developments, such as the use of lasers, computers and robots, and with modern medical techniques. As the Solomon Islands is a developing nation, most of the modern technology used in the country is imported from overseas. Therefore, it seems reasonable that the teachers would perceive such technologies to be foreign in origin (Sade & Coll, 2003). The teachers made specific reference to technology as artefacts which are used elsewhere in the world, but only recently introduced into the Solomon Islands.

Teachers viewed technology to be foreign artefacts; likewise, many viewed indigenous technology as being locally made artefacts. Both views were about technology as artefacts. The ongoing use of the same local (natural) materials for constructing of artefacts like past generations in the modern era was also perceived as indigenous technology. The teachers' views of indigenous technology were referenced to locally made artefacts within the country particularly by past generations, or a modernised version of similar artefacts made by the present generation.

de Vries (2005) states that technology as making things is often the first thing children think of in response to the question *What is technology?* This view of technology as making things was also reflected in the comments made by the teachers in this study reflecting the notion that technology is a process or an activity undertaken, with a product or an artefact as the outcome. However, the activities highlighted by teachers seem to be dominated by school-based activities, made in reference to school-related activities students were involved in, such as making furniture, model houses and play environments for younger children. This suggests that the teachers' view of technology as making things was not only focused on product making but also limited to school-based project activities. The views teachers held about technology as making things were focussed mainly on skilled-related activities, and focussed on the technical aspects of technology. Black (1994) points out that teachers with technology concepts linked to making things usually only focused on vocation-oriented purposes when they teach. As these teachers had technical education teaching backgrounds, the influence of

the technical subject subculture (Jones & Carr, 1993) was very evident in their views. Thus, the need for the enhancement of teachers' understanding of the nature of technology and technology education in the Solomon Islands was justified.

The views teachers held on indigenous technology as traditional ways of doing things were somewhat similar to their views of technology as making things. Their views of indigenous technology as traditional ways of doing things were made in reference to the traditional practices in terms of making gardens and constructing buildings in the Solomon Islands. Both of these traditional practices are still widely practiced today, even in urban society in the Solomon Islands, like in Honiara where the study was undertaken, and by some of the teacher participants. This view of indigenous technology has reflected the notion of origin of the practices as part and parcel of the people's way of life. This view also related to the view teachers held about indigenous technology as the use of traditional (natural) materials as previously discussed. The traditional materials used by past generations referred to those mainly used for building construction and the use of these same materials today, and this was perceived as indigenous technology. Therefore, the transition of these traditional materials from past generations through to the present generation has perceived to be the use of indigenous technology in a modern era. This highlights the historical aspects of technology as Rennie (1987) comments that some teachers recognised the historical era of technology, as there exists a history of changing technology.

These experienced secondary school teachers in the Solomon Islands viewed the continuation or the on-going traditional practices as evidence of a transition of the indigenous technology into a new or modern era. Technology was thus perceived as the way the world evolves and becomes more civilised (Sade, 2002). The teachers in this study associated modern technologies as new and foreign practices. In contrast, indigenous technologies were associated with old traditional ways of doing things, and a more traditional lifestyle, as is still practised today in most rural areas and by some people in the urban areas of the Solomon Islands. Some teachers made clear, sometimes negative, comparisons between the kind of technology that existed before and more modern technologies. Staudenmaier (1985) states that technology determines the way people live, and as a consequence, modern technology changes people's lifestyles and their ways of doing things. These changes are evident as people move from the old systems to the new, for example, in the transportation and communication systems. The existence of modern transportation and communication

technology in the Solomon Islands determines people's choices in travelling and communication, and this makes a major contribution to the teachers' perceptions of technology (Sade & Coll, 2003).

A factor influencing teachers' perceptions of technology was their observations on how technology impacted on people and society in the Solomon Islands. Staudenmaier (1985) points out that technology shapes and influences people's lives and the way they do things. The impact of technology on people and society influenced the views these teachers held on technology and indigenous technology.

Another view some teachers held was of technology as applied knowledge and their views also forms part of the limited understanding teachers had of technology. The teachers considered technology to be the application of practical knowledge and skills when using technological tools to perform a technological activity. Thus technical trades, such as carpentry and furniture making, were all regarded as technological activities. Teachers placed a particular emphasis on skilled jobs involving the use of machines and hand tools. By undertaking these technological activities, skills and know-how knowledge were applied. Thus, the completed buildings and finished artefacts were seen as evidence of practical know-how being put into practice. Teachers in the study considered that both knowledge and skills were useful and should always be applied when constructing a product. However, Pacey (1993) states that technological practice is much broader, involving the application of scientific and other knowledge to practical tasks, and the application must be relevant for the students when faced with a real-life situation in society. Although the teachers in the study commented that scientific knowledge was also technological knowledge, this view was still vague in terms of the relationship, between scientific knowledge and technological knowledge and tended to focus more on the technical know-how for building construction work. Custer (1995) explains that technological knowledge is the knowledge of accumulated practice, which can become quite specific when transformed into learning technological process. He further explains that technological processes represent arenas of activity generally focused around the performance of technological activities. This view was similar to the present work with the Solomon Island secondary school teachers talking about the technical know-how aspects of technology. Thus their focus related to a narrow skills-related know-how type knowledge required for undertaking activities. This view held by the teachers

is likely to impact on their teaching and learning of technology education in the Solomon Islands.

Teachers' technical education focused views of technology education

Teachers in the study held narrow views about what they thought was technology education. A majority of teachers viewed technology education as a technical, hands-on activities form of education, while a few teachers thought of technology education as an innovative and creative form of education. Although the teachers' views of technology education were categorised under these two themes, both themes were centred very much around technology as craft skill oriented education with the integration of design to foster creativity, but still strongly focussed on a vocational orientation (Black, 1994). The teachers' existing views of technology education were only focused on the technical aspects of technical education. This was evident in their comments, as they talked mainly about the technical hands-on or skills related activities they undertook as the focus of their traditional technical education. The teachers' technical education teaching backgrounds were an influence on their views of technology education. This confirmed Jones and Carr's (1993) finding that teachers' subject sub-cultures were the major influencing factor on teachers' views about technology education. When the study teachers talked about technology education as technical hands-on activities they made references to practical skills oriented activities, where students were given opportunities to make something to improve their manual skills. The teachers' view about technology education focused only on the technical hands-on activities was more of a narrow craft skill and vocation-oriented view of technology education as described by Black (1994). This view of technology does not reflect the notion of technological literacy as is proposed in the technology curriculum in the Solomon Islands.

The teachers' narrow view of technology education as a skills and vocation-oriented form of education was again reiterated when teachers talked about the value or worthiness of learning technology education at school. The importance of technical skills and practical knowledge was highlighted by these teachers as the most appropriate approach to preparing students for vocational careers after leaving school. Thus, the focus of these teachers on technology education was for vocation-oriented purposes (Black, 1994). Furthermore, teachers talked about technology education as a subject crucial for the less academic students, those who would not go on to university study, and for those students who would not complete their secondary education and needed some kind of basic skills for living in rural communities in

the Solomon Islands. The focus for teachers on the technical skills related nature of technical education.

The teachers' perceptions of classroom technology activities as technical hands-on activities also demonstrated their narrow views of technology education. When teachers talked about their classroom technology activities, they again highlighted the technical hands-on related activities students actually undertook in the classrooms. These alternatives focussed on technical skills oriented activities, and included the students learning about the uses of different hand tools, and using tools to undertake their technology activities. The teachers, who talked about teaching their technology tasks based on the Industrial Arts textbooks, also focused on the technical know-how knowledge content and technical oriented activities provided in these textbooks, these only focused on woodworking and metalworking tasks. Thus the teachers' narrow technical views of technology education were strongly held as they were reflected again in their views about classroom technology activities.

With this narrow view of technology education as being technical hands-on activities, the teachers' comments on technological pedagogy as having a technical focus were very apparent. The teachers talked about providing technical hands-on based activities as the approach for teaching technology education. Their existing perceptions of a technological pedagogy used for teaching technology education was focused on teaching technical skills through engaging students in making things. This limited understanding of technological pedagogy is likely to influence the way teachers will teach technology in their classrooms, particularly in regard to the newly proposed technology curriculum in the Solomon Islands.

The views these Solomon Islands teachers held on technology and technology education were limited. As de Vries, (2005) and Mitcham (1994) explain, technology is more than artefacts or objects and mental knowledge, it is also a process that involves human activity, the actions of making, and the processes of using technology. Cluster (1995) adds that technological knowledge is the knowledge of cumulative practices. Layton (1993) describes the holistic nature of technology as a "seamless web of interactive components in a complex socio-technical system" (p. 26). These broad views of technology and technology education shared by various scholars contrasted with the views the Solomon Islands participant secondary school teachers held on technology and technology education. They were limited, and reflected their narrow understanding of the nature of technology and technology education,

they focussed on artefact-related perspectives and technical skill-based activities, reflecting only a single dimension of technology education. These teachers' limited understandings of the nature of technology and technology education is likely to influence their teaching of the proposed technology curriculum (Jones & Compton, 1998). The next section discusses the teachers' technical views of technology education as was illustrated in each of their classroom practices.

9.3.2 Teachers' Conventional Prescriptive Teaching Practices

As has been previously stated, the current Industrial Arts teachers are to teach the new technology curriculum in the Solomon Islands. Therefore, understanding their existing classroom practices is crucial for the successful implementation of the new technology curriculum. As teacher perceptions and classroom practices are strongly influenced by subject sub-cultures (Goodson, 1985; Jones & Carr, 1992; Paechter, 1992), the participant teachers' technical education background contributed to their classroom practices. It became apparent that their classroom practices were strongly technical and conservative, with the use of textbook-based prescriptive teaching, fragmented teaching and learning situations closed tasks teaching approaches, classroom and workshop confined teaching, and a limited understanding of assessment practices.

Prescribed documents based teaching

Curriculum development in the Solomon Islands is centralised, so almost all the participant teachers' teaching documents were based on those supplied by the Ministry of Education (MoE). The study shows that the use of the MoE-produced curriculum documents influenced the way the participant teachers' planned and taught their lessons in 2005. As these MoE teaching documents clearly prescribed teaching procedures and student notes, teachers who used the MoE teaching documents needed to do less preparation. The teachers then followed the textbook outlines as recipe books. As the prescribed curriculum documents had technical oriented education, teachers taught technology this way.

An aspect missing from the teachers' teaching documents was the evidence of written learning outcomes. Teachers only indicated their learning outcomes verbally when asked about this. The learning outcomes expressed were based on the content of the textbooks. This was not surprising because what the teachers were expecting the students to understand was presented in their notes. However, by following the prescribed teaching documents teachers

were deprived of the opportunity to plan their own lessons, write their own learning outcomes, and to develop a broader teaching approach.

The emphasis in the textbooks was on either the process involved in manufacturing products, or the working procedures students needed to understand and follow in order to acquire particular technical skills. These working procedures were the main focus for most teachers when teaching their theoretical lessons. Some of the working procedures were more specific to specific tasks and were outlined as student activities. Sometimes the students were given the textbooks and told to copy the notes straight from the textbooks into their exercise books. Hence most of the students' activities were textbook-based and skills oriented. The textbook prescriptive teaching reflected the dissemination theory of behaviourism, where learning is passed down through the textbooks and the teacher to the students. This is in contrast to the social constructivist and socio-cultural view of learning underpinning the effective student learning in technology education (Compton & Harwood, 2007; Jones & Moreland, 2004).

The use of the textbooks as recipe books for teaching was a common practice for four teachers in this study. The teachers turned to textbook-oriented teaching simply because the textbooks already contained the ready-made student notes, home work, and quiz questions etc. The pre-written quiz book was also based on the textbook notes. Textbook-oriented teaching is relatively easy because the teacher only needs to follow the instructions outlined in the textbooks and they do not need to plan and prepare their own lessons. With this teaching approach, the student learning was very structured and tightly confined, as they were directed to learn from the content of the textbooks, seen by these teachers as the sole determining factor for what students should be learning. However, de Vries, (2005) points out that not all technological knowledge can be taught through textbooks or oral instruction.

However, as was also evident in the teachers' teaching documents, the other four participant teachers were individually and independently planning and teaching their own lessons, rather than following the prescribed lessons as outlined in the MoE textbooks. This confirms the notion that teachers are the key decision-makers and have control over what is taught in the classroom (McGee, 1997). The initiative taken by these four teachers also indicated their desire to change from the traditional textbook teaching approach. However, even though these teachers preferred to plan and use their lessons, their own lesson plans still focused on working procedures, and a technical skills emphasis orientation.

Fragmented teaching and learning situations

The MoE-produced Industrial Arts documents had a strong influence on what and how teachers taught their lessons, in that lessons were to be divided into two parts; first the theoretical lesson and second, the practical lesson. The teachers' fragmented teaching of theoretical lessons and students' practical activities were influenced by several factors. One of the main contributing factors to how the MoE Industrial Arts produced document-influenced teaching and learning situations in schools was the organisation of timetables to cater for both theoretical and practical lessons. For the junior forms, only three 40 minute class periods were allocated for Industrial Arts. Therefore, a single period of 40 minutes was allocated for teaching theoretical lessons, and a double period of 80 minutes for teaching practical activities. For the senior forms, five periods of 40 minutes were allocated for Design and Technology. Therefore, a single period of 40 minutes was allocated for teaching theoretical lessons and a pair of double periods of 80 minutes each for practical activities in most schools. With this arrangement of class periods, fragmented teaching of theoretical lessons and students' practical activities was almost inevitable.

The subdivision of class periods in schools influenced the way teachers planned and taught their lessons, with most teachers organising their lessons in a similar manner, resulting in theoretical lessons and practical activities being planned and taught separately. In some cases, the teachers' 2005 teaching documents and lesson sequences showed no links between theoretical lessons and practical activities. One of the factors contributing to fragmented teaching was that most teachers based their theoretical lessons on the MoE-produced documents while the students' tasks were initiated by the teachers themselves. Although the tasks gave students hands-on experience, the practical activities were often unrelated to the theoretical lessons as prescribed in the MoE-produced documents, yet they were meant to be taught together. However, the teachers often decided to initiate practical tasks other than those prescribed in the textbooks, contributing to the mismatch of theoretical lessons and practical activities. This was another indication of teachers as key decision-makers (McGee, 1997). Even the teachers who based both of their lessons on the MoE-produced textbooks also fell into this pattern of teaching two unrelated lessons during observations (see section 5.3.1 under teachers' preferences). Ginner (2007) points out that the concept of theory and practice should be removed when teaching technology education, as their separation is a hindrance to developing technological literacy.

Other factors also contributing to fragmented teaching of theoretical lessons and students' practical activities were the lack of facilities and equipment and the lack of financial support from the administrators. Due to there being no workshops and equipment in some schools, teachers only taught theoretical lessons without giving students any practical hands-on experiences. Facilities, equipment, and tools are vital to students' practical activities, so there being no practical activities for students in some schools, the result was the one-sided teaching and learning of theoretical lessons outlined in the MoE Industrial Arts / Design and Technology documents. Although some schools had equipment and tools, the lack of financial support from their administrators was a contributor to only theoretical lessons being delivered. Due to the required materials not being paid for, the students were denied the opportunity for hands-on experiences. In these situations, teachers focussed only on theoretical lessons and totally ignored practical, hands-on activities. These difficulties left the teachers with less room to teach a holistic technology curriculum. Jones, Harlow and Cowie (2004) point out that existing school structures, existing facilities (or lack of them) and examination requirements are major factors influencing how teachers taught technology in the classroom.

Prescribed closed task activities approach

Another narrow teaching and learning situation in 2005 was the use of prescribed closed task activities. Most of the participant teachers used prescribed closed tasks when undertaking class projects. This approach was about teachers designing the tasks and then giving instructions for students to follow when they constructed. In so doing, the students did not have much room to contribute their own ideas or have any input into how the task should be done. Instead, students were asked to closely follow the teachers' instructions so that they replicated their teacher-designed tasks. Hence, by the end of the task, the students' finished products all looked exactly alike and were similar to the model the teachers had in mind (see Figure 5.4 and Figure 5.7). The focus of this kind of class project was on making and acquiring skills by undertaking given tasks, and only fostered passive learning on the students' part. This kind of approach forfeited the conceptual and societal aspects of technology which are key learning domains contributed to the development of technological literacy (Dyrenfurth, 1990; ITEA, 2000; McComick, 1997; MoE, 1995).

The prescribed closed task teaching approach which teachers used in 2005 was teacher-centred and teacher-dominated. The teachers made all the key decisions on how the students

should perform their class tasks. In other words, the teachers planned the work and delivered it to the students to replicate. Teaching was about giving instructions on how to undertake a task, emphasising the prescribed notes in the textbooks. At times, it seemed like a repetition of the same things already outlined in the textbooks. In the classroom, the teachers did most of the talking, and sometimes talked for almost the entire period. Students made few contributions in regard to the task, as they were only expected to follow the teachers' instructions. Any student input into the tasks was seen as heading off-track in the wrong direction from the prescription given by the teachers. In these situations, the teachers perceived themselves as the resource person with all the knowledge and the know-how for getting the students to accomplish their tasks. Thus the students were there to absorb all the knowledge from the teachers as passive learners. Unfortunately, this approach marginalised the empowerment of students as decision-makers, particularly in terms of understanding of technological development (Compton & Harwood, 2003).

Classroom confined teaching

Teachers either used the students' home classrooms or the workshops to teach their lessons as Jones (2003) highlighted about technology education teachers in New Zealand. The classroom context was perceived by the teachers as the only venue for teaching and learning, and all teachers confined their teaching and learning to this setting. The classroom culture was the major influence on the teachers' views as the place for teaching and learning with the use of textbooks as the primary teaching/learning resource materials, with other classroom resources like blackboards, desks, and the building itself seen as secondary. The teachers were very used to teaching within classrooms. Therefore, anything else would not be expected to be an avenue to foster teaching and learning. In addition, the prescribed textbook-based teaching approach had a major influence on the teachers' views of teaching and learning in 2005. The activities outlined in the MoE prescribed textbooks were geared towards either classroom-based theoretical lessons or workshop-based practical activities. This practice of confining teaching and learning to only classroom contexts marginalised the notion of learning in technology through enculturation (Jones & Moreland, 2004), cognitive apprenticeship (Brown, Collins, & Duguid, 1989), and exposing students to the communities of practice (Dakers, 2005; Lave, 1991).

Teachers' limited understanding of assessment practices

Teacher-student interaction in 2005 indicated that teachers had limited understanding of formative assessment or assessment for learning. The teachers were confused about the idea of assessment for learning. Therefore, formative interactions between teachers and students in the classrooms were not fully utilised. Most of the teachers' conversations with students were one-sided or otherwise heavily dominated by the teachers, even when students responded to teachers in conversation. In addition, the type of questions teachers asked students during classroom interactions, being more closed, fostered limited responses from the students. The responses given by students were limited, short, and at times were just a single word. On some occasions, silence was the only response from students. In these incidences, the teachers often had to answer their own questions just to keep the one-sided conversation alive. Thus, the formative interactions between teachers and students in classrooms were teacher-dominated conversations. Dakers (2005) states that teacher-students interaction that is a monologue, or a one-way process dominated by teachers, is the key characteristic of transmission learning model. In some instances, teachers asked open questions then responded positively to the students if answers were correct and responded negatively if answers were incorrect. Sinclair and Coulter (1975) talk about IRF approach, which means teacher Initiation, student Response, teacher Feedback. Feedback is viewed as positive if students' answers are correct, or negative if incorrect. The use of this form of IRF often scared students into not answering, especially when they were unsure if their answers were correct. This then resulted in students remaining silent during teacher-student interaction in the classrooms. However, Jones and Moreland (2004) point out that student learning could be enhanced if the teachers' focus was on more precise formative interactions and providing feedback that prompted students to think about the strengths and weaknesses of their work.

In teaching situations, the teachers used informal forms of summative assessment to interact with students and to spot-check students' understanding of the lessons by verbal posing revision questions. This form of teacher-student interaction was only an informal form of summative assessment as the teachers just wanted to get some idea of how well their lesson had been taught. When undertaking their informal forms of summative assessment, the teachers used recall questions to check student understanding of the tasks. The other form of summative assessment used was the informal type of summative assessment where teachers used recall questions. It was also interesting to note that some teachers based their informal summative assessment on assumptions. Some teachers assumed that if students did not

understand the lesson, they would ask questions, and if they did not ask any questions then they must have understood the lesson. Other teachers assumed that if their planned lessons were covered within the class time, then the lessons should be understood by the students.

The teachers' more formal summative assessment practices were also limited, as they were based only on the assessment criteria provided in the MoE-produced documents such as homework, skills assessments and unit tests. Theoretical lessons were assessed using a written test and the outcomes of the practical tasks were assessed after the completion of the tasks. The teachers' assessment practices were influenced mainly by the assessment policy prescribed in the MoE documents. The MoE-produced quiz books contained multiple quiz questions based on each unit, and teachers just used these quiz books to assess their theoretical lessons. The assessment criteria for practical tasks were also outlined in the MoE-produced documents or the syllabus which teachers also used as a guide for assessing practical tasks. These assessment practices and views teachers held on assessment indicated that teachers' held limited understanding about assessment.

In answering research question one, the teachers' existing perceptions of technology and technology education were narrow and limited to artefacts-related with a technical education focus. The teachers' classroom practices were conservative and traditionally teacher dominant with more emphasis on passive learning. The issues discussed around research question one resulted in the development of the PD programme undertaken in this study. The impacts of the PD programme on teachers and students are discussed next.

9.3 Impact of the Professional Development Programme

This section begins with a discussion about the impact of the professional development undertaken in 2006 on enhancing teachers' understanding of the nature of technology and technology education in section 9.3.1. Teachers' changed views on technology and technology education are discussed next, in section 9.3.2, followed by discussion of the impacts of teachers' enhanced understanding of the nature of technology and technology education on classroom practices in section 9.3.3. Section 9.3.4 discusses the impact of teachers' changed classroom practice on students' learning experience, followed by a discussion of the impact of factors hindering teachers' enhanced teaching practices in section 9.3.5. This section ends with discussion on the impact of effective professional development

in enhancing teachers' understanding of the nature of technology and technology education in section 9.3.6. The discussion in this section is focused on the third and fourth research questions:

3. What effect and influence does a professional development programme have on teachers' concepts of technology and technology education, and their classroom practices?
4. What is the influence of teachers' developing understanding and practices in technology education have on student learning?

9.3.1 Effects of the Key Characteristics the Professional Development Programme

Based on the narrow views the secondary school teachers held on technology and technology education, and their technical education dominated classroom practices, it was necessary for the teachers to undertake a professional development (PD) intervention programme to enhance their perceptions of technology and technology education, and their classroom practices. It is important that technology education teachers develop a robust subject sub-culture in order for the technology curriculum to be effectively translated into technology programmes in schools (Compton & Harwood, 2003; Jones, 2003; Jones & Moreland, 2004). This notion underlines the main objectives of the PD intervention programme as it sought to enable the teachers in the Solomon Islands to develop a robust subject sub-culture in technology education. It is very difficult to bring about teacher change because of its complexity (Bell, 1993; Jones & Carr, 1992; McGee, 1997). However, a well structured PD programme can influence teachers to see the need for change (Bell, 1993; McGee, 1997). de Vries and Tamir (1997) state that learning in technology means taking into account both the rational and non-rational factors which reflect learning in technology as a truly human affair. They add that social constructivism is a key issue underpinning the sociology and philosophy of technology. The social constructivist theoretical framework, which takes into account interaction and a collaborative approach, coupled with the key characteristics of sound professional development programmes, namely on-going professional development, teacher reflection and sharing, and teacher support and feedback (Bell, 1993; Bell, 2005; Bell & Gilbert, 1996; Jones & Moreland, 2004) formed the basis of the PD programme. These combined strategies were found to be very effective in enhancing the experienced teachers' understanding of the nature of technology and technology education. Their understanding and practices in teaching technology education also impacted on classroom practices in the Solomon Islands, changing them. Consequently, the teachers developed more robust concepts of technology and technology education (Compton, & Harwood, 2003; Jones 2003; Jones &

Moreland, 2004), developed an understanding of associated pedagogical content knowledge (PCK) of technology education (Jones & Moreland, 2004), and gained hands-on experience in trialling technological activities in their classrooms (Jones, 2003). Jones and Moreland (2004) argue that the nature of technology and technology education is part of the construct of technology pedagogical content knowledge where teachers need to be knowledgeable in order for technology to be effectively taught. The details of the impact of the PD programme on teachers' enhanced views of technology and technology education are discussed below in section 9.3.2 and the impact of the teachers' enhanced understanding of the nature of technology and technology education on their classroom practices are discussed in section 9.3.3.

The key characteristics of the professional development programme, such as on-going PD programmes with workshops followed by classroom practice, teacher reflection and sharing, and teacher support with classroom practice, all fostered social interaction between the teachers and the PD provider during the workshop and classroom practice sessions. The programme proved to be effective for enhancing teachers' understandings of the nature of technology and technology education, impacted on teachers' teaching practices in technology education and influenced on student learning. Evident in the teachers' comments, the ongoing approach undertaken in PD programme really motivated and encouraged them to look forward to the next workshops, so they could share their teaching experiences, and could learn from what their colleagues had to share. It also gave them the opportunity to use the workshops as a time to clearly on any doubts and questions that they may have had. It should be noted that six of these eight participant teachers were part of the team that helped developed the new Solomon Islands technology curriculum, so this PD programme was a bonus for them, and could be viewed as part of their ongoing PD. Thus, the social interaction, coupled with an ongoing PD programme, was effective in enhancing the experienced teachers' understanding of the nature of technology and technology education, also helping them build a more robust subject sub-culture as found in other studies in New Zealand (Compton & Harwood, 2003; Jones & Moreland, 2004).

Compton and Jones (1998), and Jones and Moreland (2004) suggest that an effective way to develop teachers' conceptualisation of technology education and other technological related aspects is through reflection on their own and others' concepts of technology, pedagogical knowledge, and technological practices. Teacher reflection and sharing was the key principle

underpinning the enhancement of teachers' understanding of the nature of technology and technology education in this professional development course. This approach encouraged teachers to reflect on their own views and make adjustments in comparison to their colleagues' views, and the views shared by other scholars on technology and technology education. The teachers could see similarities and differences between their views and their colleagues', and those held by the scholars on technology and technology education. This comparison influenced the teachers to change their views of technology and technology education. Consequently, the teachers' changed views tended to reflect the scholars' views of technology and technology education (see section 9.3.2) as they absorbed this learning. Teachers believed that they learnt from reflecting on their teaching experiences and the sharing exercises with colleagues during the workshops. Hence, more teacher reflection and sharing time was specifically requested by teachers in their evaluation of Workshop One. This request confirmed teacher reflection and sharing was effective for enhancing and consolidating teachers' conceptualisation of the nature of technology and technology education and their teaching practices.

Jones and Moreland (2004) point out that use of teacher support in the classroom during professional development enhances teacher confidence in trialling new ideas. Likewise, the teachers in this study used the school visits as a time for confirmation and assurance from the PD provider as to whether they were doing the right thing. This checking process gave the teachers the confidence to continue with what they had been doing, or to seek more clarification on what needed to be done with their teaching practice. Teachers always looked forward to the school visits and talked about the support provided by the PD provider as a time they could get some of their questions answered. The one-on-one teacher support was appreciated by teachers and was provided on a regular basis to teachers both inside and outside the classroom. This support enabled teachers to get help and quick feedback to enhance their teaching practice. As teachers were so enthusiastic about their teaching practice, they continued to seek support from the PD provider outside the scheduled school visit timetables. Apart from the scheduled school visit times, other meetings also occurred at odd places and times such as on the streets when teachers were doing their shopping, on the bus as teachers returned home after school, and at the soccer stadium. These occasions and chance meetings were used by the teachers as opportunities to share with the PD provider, as they reflected on the PD and their classroom practice. These unscheduled meetings also provided teachers with immediate feedback and support as they did not have to wait for the

scheduled school visits. The meeting times teachers had with the PD provider were always valued by the teacher participants, as they assisted in building confidence in their technology teaching tasks. Teacher support was crucial in assisting the experienced teachers in the Solomon Islands to develop confidence during the transition of their classroom practices from the traditional, prescriptive, skilled-based teaching approach to using the design teaching approach in teaching technology education.

These changes, undertaken by the experienced teachers, were the result of being part of a PD programme that took into account strategies such as an ongoing professional development, teacher learning through reflection, interaction and collaboration during workshops, and teacher support during both workshop and classroom sessions (Bell, 2005; Bell & Gilbert, 1996; Jones, 2003; Jones & Moreland, 2004). These strategies promoted learning through social interaction and negotiated intervention (Hennessy, 1993) part of the social constructivism theoretical framework, on which this study is based.

9.3.2 Impact on Teachers' Perceptions of Technology and Technology Education

This section discusses the impact of the professional development intervention programme on the teachers' perceptions of technology and technology education. The findings revealed that teachers' previously held narrow views of technology and technology education in 2005 as discussed in Chapter Four had changed in 2006 as discussed in Chapter Seven. The changed perceptions were evident in the teachers' conversations during the sessions of the last two workshops, the two classroom practice sessions and also in the teachers' responses to the questionnaire at the end of the PD programme. The sessions of the first workshop, which focussed on enhancing perceptions of technology and technology education effectively changed the teachers' views of technology and technology education. They became focussed on technology as a process used for solving technological problems to meet the needs of society and technology education, and as design activities with a problem-solving focus. The details of the teachers' changed views of technology and technology education are discussed next.

Teachers' changed views of technology

The teachers' limited understanding of the nature of technology with artefact-related perspectives changed to include technology as a process used for solving technological problems to meet the needs of society. This change to viewing technology as a process

humans undertook for solving technological problems in society, portrays technology as a human activity (Compton & Jones, 2004; de Vries, 2005; Ginner, 2007; Mitcham, 1994; MoE, 1995). The teachers' changed views were very similar to the range of technology definitions (see Appendix 14) shared by scholars such as Burns (1992), Compton and Jones (2004), Cutcliff (1981), Johnson (1989), Lux (1983), Naughton (1992), Pacey (1993) etc. The technology definitions shared by these scholars were discussed in Workshop One and I believe that this discussion influenced the changes in teachers' views of technology. Teachers no longer saw technology as just an artefact but rather as a process for addressing practical problems in society, indicating that teachers' understanding of the nature of technology was enhanced as a consequence of the professional development programme in 2006. When teachers talked about technology in particular, either during the last two workshops or during a conversation in both of the classroom practice sessions, they made references to technology as human activities which involved technological problem-solving in society or addressed the needs of society (Compton & Jones, 2004). The consistency of this view of technology was evident in all teachers' comments. Other factors in Workshop One which also contributed to influencing the teachers' views of technology were the video clips with a technological problem-solving focus, and the presentation of local technological problems with proposed technological solutions. The content of the workshops was focused on technology as a problem-solving concept to meet the needs of individuals, communities and societies, therefore, the teachers also viewed technology as a way to find technological solutions for today's problems. Thus, the impact of the PD programme on enhancing teachers' understanding of the nature of technology was evident.

Teachers changed views of technology education

The views teachers held about technology education also changed from a technical education perspective to technology education as design activities with a problem-solving focus (Jones & Moreland, 2004; Moreland, 2003). The views teachers held about technology education as design activities with a problem-solving focus were consistent with the views they held on technology as a process used for solving technological problems to meet the needs of society. This consistency indicated that there were links between the teachers' views of technology and technology education.

de Vries and Tamir (1997) state that conceptual knowledge is an essential component in technological design and the problem-solving process, as the design process combines

knowledge about concepts (declarative knowledge) and process (procedural, situational and strategic knowledge). The teachers' learning outcomes and activities described in their lesson planning formats in 2006 were focused on four learning domains: conceptual, procedural, technical and societal. The design process teaching approach the teachers used when planning their technology lessons on Day Two of Workshop One was a key factor which influenced the teachers' views of technology education as design activities with a problem-solving focus. When the teachers commented on the change in their teaching approach, they made reference to the design process as a teaching approach unique to technology education. This was perceived by teachers to be quite different from the traditional approach to teaching Industrial Arts. The teachers who did not follow a design process approach in teaching said that they were not teaching technology education as fully intended. This indicated that these experienced Solomon Islands teachers considered the design aspect of technology education to be a significant aspect of teaching and learning in technology education. The design process is a pedagogical approach generally used for technology education (Black, 1994; Jones & Carr, 1993; Jones & Moreland, 2004; McCormick, 1997). Black (1994) talks about technology as practical capability, where technology centres around a complex process focused on defining needs, designing, implementing and evaluating solutions, and adds that the design process aspects of technology education depict a much broader view of technology education. The interrelation of technology and society was a key theme highlighted throughout the PD programme. Therefore, meeting the needs of society was perceived as an important objective in the problem-solving aspects of the design activities in technology education. Thus the focus of the teachers' design activities, based on addressing the needs of society, schools and communities, demonstrated that teachers' understanding of the nature of technology and technology education was enhanced. While the teachers' main focus in technology education was on design activities with a problem-solving focus, other aspects of technology education were also highlighted by the teachers. The inclusion of the societal learning outcomes in one of the lesson plan formats also demonstrated the teachers' enhanced perceptions of technology education and included understanding of the inter-relationship of technology and society (Dakers, 2005; Pacey, 1983; Staudenmaier, 1985) as a learning aspect in technology education (Compton & Jones, 2004; MoE, 1995).

In summary, the use of the technology definitions (see Appendix N), video clips, PowerPoint slides and reading materials, lesson plan formats during the PD programme contributed to the teachers' enhanced understanding of the nature of technology and technology education. The

video clips and the lesson planning formats, incorporating a design process teaching approach with learning outcomes under conceptual, procedural, technical and societal themes impacted on teachers' understanding and teaching practice in technology education. The social constructivist theoretical view, based on discourse and interaction with the PD provider and colleagues, coupled with these resource materials, were found to be effective in helping the experienced teachers establish a common understanding of the nature of technology and technology education and technology pedagogical content knowledge. Enhancing teachers' understanding of the nature of technology and technology education and pedagogical content knowledge was crucial in dispelling the teachers' misconceptions around technology and technology education, which subsequently impacted on their classroom practices in teaching technology education. The impact of teachers' enhanced understanding of the nature of technology and technology education on teachers' classroom practices are discussed next.

9.3.3 Impact on Classroom Practices

This section discusses the impact of the teachers' enhanced understanding of the nature of technology and technology education on their classroom practices. The findings revealed that as teachers' understanding of the nature of technology and technology education was enhanced, so was their understanding of technology pedagogical content knowledge in technology education. The changes to classroom practices included teachers' engagement in their own planning of technology lessons, changes to teaching pedagogies and enhanced assessment practices.

Teachers' planning of technology lessons

In 2005, teachers based their teachings on the MoE-produced textbooks, which meant they did not have much planning and preparation to do. The technology lesson planning sessions incorporated in the PD intervention programme in 2006 aimed to enhance teachers' understanding of planning a technology lesson and to provide them with experiences in teaching their own technology lessons. This was a change from the use of MoE-produced textbooks which did not have clearly stated learning outcomes for teachers to base their lessons on in 2005. The lesson planning exercise introduced to the teachers during the PD planning sessions also exposed them to new lesson plan formats. These formats covered a broad perspective of technology education. With the new lesson plan formats, teachers experienced the writing of generic and specific learning outcomes under four learning aspects: conceptual, procedural, technical and societal (Jones & Moreland, 2004; Moreland,

2004). The lesson planning sessions enabled them to think about and write clearer generic and specific learning outcomes under these four learning aspects and these were also the focus for teaching their technology units. Jones and Moreland (2004) highlight that the use of all these aspects in planning lessons was critical for providing a comprehensive and balanced approach to teaching technology. The planning exercise provided in the PD programme enabled the teachers to teach their units using clearly stated learning outcomes. The new formats also enabled them to plan their unit tasks in sequences, week by week throughout semester two of 2006. The design process teaching approach enabled the teachers to outline the lesson sequences of their task activities under three main phases of the design process: designing, making, and evaluating. The lesson planning activity enabled the experienced teachers to see that they could still use their existing unit tasks and apply the new formats to planning in order to more clearly outline these tasks. They could also add in the generic and specific learning outcomes of their technology unit tasks, and incorporate the design process teaching approach. Both lesson plan formats used by teachers indicated that their views of technology education is broadened to include a design process and to combine knowledge of concepts and processes (de Vries & Tamir, 1997). It had also broadened to include societal aspects (Compton & Jones, 2004) rather than simply focussing on the technical aspects. Being able to identify learning outcomes under the four learning aspects demonstrated the teachers' enhanced understanding of technology and technology education.

Curriculum development in the Solomon Islands is centrally oriented. Therefore, most teaching materials are supplied by the Curriculum Development Centre of the MoE. Furthermore, most teachers base their lessons on the MoE-produced textbooks and do not get the opportunity to include their own planning in their lessons. So, the use of new lesson planning formats was a new activity for the teachers and consequently, most of them found the lesson planning activities difficult. However, they were quite happy to have a go at planning their own technology lessons. The teachers gained confidence in developing the technical aspects, including the technical learning outcomes and the technical activities listed under the making phase of the design process. The teachers' technical learning outcomes were focused mainly on technical skills required for technical drawing and hands-on activities for undertaking technology tasks. The technical aspect was an area the teachers were more familiar with, reflecting the experienced teachers' technical education subject sub-culture background (Jones & Carr, 1992). The aspects teachers in this study had difficulties with were the conceptual and societal learning aspects. In this case, most teachers decided to

adopt the conceptual and societal learning outcomes from the first example lesson format (see Figure 6.2), and the sequence of activities under the designing phase of the design process planning from the second example lesson format (see Figure 6.3). Similarly, Jones and Moreland (2004) also found that teachers in New Zealand had difficulty in identifying learning outcomes in the conceptual and societal learning areas in their initial lesson planning. Although teachers attempted to plan their own technology lessons using these new formats, they were not confident in identifying learning outcomes when planning technology lessons and requested more practice and assistance in this area.

Another change related to the teachers' lesson planning was the integration of theoretical and practical lessons. Ginner (2007) states that teaching of theory and practice separately should be done away with in technology education. The teachers' lesson sequences clearly indicated the integration of theoretical lessons with practical activities. The lesson formats provided the teachers with the opportunity to think about how theoretical lessons need to be integrated with the practical activities, to maximize students' learning. Teachers recognised the importance of integrating theoretical lessons in relation to the practical tasks, as there is an intimate connection between knowing and doing (Brown, et al., 1989; Hennessy, 1993; Resnick, 1991). The integration of theoretical lessons with practical lessons was not only evident in the teachers' planning of their lessons but was also evident in the teachers' comments, as they talked about their teaching experiences. Teachers talked about teaching theoretical lessons alongside their practical lessons where they endeavoured to provide students with the necessary information at the right time to move them forward with a task. Additionally, the integration of theoretical lessons with practical lessons was viewed as a way to save time, enabling students to get their technology tasks completed within the expected timeframe. The shift from textbook-based teaching to teaching using their own lesson plans gave these teachers the confidence to teach without directly relying on the MoE textbooks. Teachers attempted to link technology tasks with real life situations in society, which was an indication of their enhanced understanding of the nature of technology and technology education. This offset the prescribed sequence outlined in the MoE textbooks. Further, some information required for undertaking the tasks was not available in the prescribed textbooks, therefore teachers and students had to look elsewhere. In some cases, teachers used notes from other resource books and in other instances teachers asked students to do research in the community for the information. By taking this approach, teachers moved away from the dissemination/transmission approach towards a socio-culture/social constructivist approach to

teaching/learning. These experiences demonstrated to the teachers that there was less need to rely on the prescribed MoE textbooks and helped boost their confidence for teaching technology from a broader perspective.

Change of teaching pedagogy

The change in their pedagogy was also influenced by teachers' enhanced understanding of the nature of technology and technology education. The teachers' change of pedagogy for teaching technology education in 2006 demonstrated that their understanding of technology pedagogical content knowledge (PCK) was enhanced. This included the understanding of a context-based teaching approach, the understanding of community involvement, the understanding of the design process teaching approach, and the understanding of the use of open-ended tasks.

Jones and Moreland (2004) list seven areas of pedagogical content knowledge (PCK) in technology that teachers need to understand to teach technology effectively, and state that one of the seven areas is to understand the role and place of context in technological problem-solving. The use of a context-based teaching approach was evident in the teachers' 2006 lesson planning and from the comments made during the PD intervention programme. The teachers in this study made references to both the school and community context in their lesson planning and when they talked about their technology lessons. The concept of context-based teaching was never mentioned in 2005. The teachers talked about context-based teaching in 2006 and made reference to school-based and community-based contexts, being perhaps the context the teachers were most familiar with. For example, teachers who had designed their technology task to be used at school talked about their technology task as based in a school context and those who designed their technology task for community use talked about their technology task as based in a community context. However, the school context based approach was dominant. The use of context-based lesson planning was another indication that the teachers' understanding of pedagogical content knowledge in technology education had been enhanced, as they talked about the context-based approach to planning their technology lessons.

The involvement of community in assisting students to undertake their technology tasks was another teaching approach used by some teachers. This was a change from the 2005 traditional, confined to classroom teaching approach and was undertaken as an attempt to

move students away from teaching and learning within only classroom settings. When teachers talked about community involvement they made references to sending students out into the community to research information related to their technology task. This teaching approach enabled students to interact with people as they sought information for their technology task, which reflected the notion that technological knowledge is socially constructed (Compton & Harwood, 2007; Jones, 2001; Jones, 2003, Jones & Moreland 2004). By including the community as part of their technology tasks, the students were able to get the information they required for designing and constructing their tasks. The teacher who sent his students to the industries which manufactured similar products to the students talked about how his students got more information required for undertaking their technology tasks from those various industries visited. Other teachers talked about student activities involving community participation, such as involving other teaching staff with the students. By pursuing this approach to teaching, the students' knowledge sources were not only textbooks or interaction with their individual technology teachers, but also their interaction with various communities of practice. Dakers (2005) states that learning is enhanced in technology education when learning experiences are extended beyond the classroom settings into the wider community. Community interaction engaged students in activities which extended to communities providing infrastructure to assist them to undertake their technology task. For example, a group of students in one of the schools engaged the aviation helicopter to fly over the school to take some aerial shots which they used for the school calendar, and engaged the business community to finance the production of their calendar. By involving the community in their technology tasks, students saw the importance of community involvement to further enhance the quality of their technology tasks. Hence, students' learning was effective as they engaged in social activities and discourse within the communities of practices (Rogoff, 1990).

The use of a design process teaching approach was another indication of change to the pedagogy of these teachers in 2006. The design process approach was the main pedagogy emphasised in the PD intervention programme in 2006. Therefore, the teachers' technology lesson plans were based on the design process approach as was their teaching. Hence, as the teachers were implementing their lesson plans they were undertaking this approach to teaching and learning in their classrooms. The use of this teaching approach broadened the teachers' understanding of technology and technology education and it was seen as an approach that involved students in undertaking activities in real life situations. The students'

activities were not based on textbooks but on the identified needs of various groups of people. Therefore, when teachers talked about students' tasks they made references to activities undertaken in real life situations. Most of the teachers talked about the design approach to teaching and learning as a better pedagogy than the traditional prescriptive textbook based teaching approach. Jones and Compton (1998) state that teachers would only embrace any change when the rewarding role in the change process was acknowledged by the teachers themselves. The teachers who trialled the design process teaching approach found this pedagogy very interesting and motivating for both the teacher and students. This teaching and learning process was very different to what both teachers and students had experienced in 2005, as it engaged students in designing their own ideas. As well it allowed students to be fully engaged in the process of learning, as they had to design and construct the task themselves, with teachers only being there to provide assistance where necessary. Therefore, teachers talked about the design process pedagogy as a very interesting approach to teaching.

The self thinking part promoted by the design process teaching approach was another area teachers highlighted in their comments. Compton and Harwood (2007) point out that self thinking fostered by the design process teaching approach reflects the theory of constructivism. This change indicated the teachers' a clear shift of teaching and learning from the traditional learning approach in 2005 to the constructivist approach in 2006. As students were given the task of designing what the product should look like, they had to do a lot of thinking themselves. This was a major change to learning from 2005. The development of students' ideas showcased in their design folios were viewed by teachers as evidence of student thoughtfulness and self thinking. The classroom activities were dominated by students as they took the lead in pursuing their tasks. Self thinking and student-dominated learning activities were evident in the design process approach to teaching the teachers implemented in 2006. In addition, the teachers talked about the design process as an iterative (Jones & Moreland, 2004) rather than a linear approach, indicating teachers' understanding of the nature of the design process teaching approach. Some teachers talked about undertaking evaluation, as their starting point, and then working back and forth through the design process when undertaking the technology tasks. Different technological professions have different ways in which to use the design process (de Vries, 2005).

Another aspect of the design process undertaken by the teachers was the use of open-ended tasks and the use of a problem-solving based approach in technology tasks. In open-ended

tasks, the decision-making focused more on student than teacher input and the students were given more freedom in designing their tasks and making their product based on relevant information gleaned from the community, or the users of the products. Consequently, some student products were made specifically to address a need which the students themselves identified at the start of the project. The open-ended nature of the technology tasks allowed individual students to participate in individual thinking as each student was able to contribute ideas or develop a possible solution to address the need and solve the problem. Unlike the previous 2005 prescribed tasks, which normally restricted all students to the same task, the nature of open-ended tasks provided individual students with an opportunity to design and make their own product. Hence students learning through open-ended tasks, gathering information from the community and the users of the products, reflected the social constructivist view of learning.

Teachers' enhanced understanding of the nature of technology and technology education which then impacted on their teaching pedagogies in 2006 facilitated the differences in students' work. Figure 9.1 shows a comparison of some examples of students' products using both the 2005 prescriptive teaching approach and the 2006 design process teaching approach.

Figure 9.1:

Student products from prescriptive and open-ended teaching approaches



The student products on the left, (previously shown in Figure 5.4 in Chapter Five) were the result of a prescriptive task approach. All products are the same. On the right are student products (previously shown in Figure 7.8 in Chapter Seven) which were the result of the open-ended task approach, demonstrating products as very individual. The difference

between the products produced by students with these two teaching approaches is apparent in Figure 9.1.

Enhanced assessment practices

The teachers' enhanced understanding of technology and technology education also impacted teachers' assessment practices. There was evidence of improvement in the teachers' assessment practices in 2006 – both in the formative interaction in the classrooms and in the summative assessment criteria. The main changes occurring in formative interactions were with the teachers' one-way and limited approach in teacher-students conversations in 2005. The change of pedagogy impacted on the teachers' 2006 formative interactions with students which became more balanced reciprocal conversations between teachers and students. The teachers' change of pedagogy encouraged students to engage in active roles in their technology tasks. Therefore, teachers' conversations with students were more of an inquiry to find out more about how the students worked, what they thought and how they were getting on with their task. When students responded to teachers' inquiries, their responses were lengthier, as they had to explain their involvement in a specific process in their technology task. This approach enabled students to feel more at ease as they freely related to their teachers in a reciprocal manner. This approach made teachers see themselves and their students in a partnership to enhance learning.

The teachers' formative interactions were also focused on moving students' learning and work forward. An effective formative interaction is based on the principles of effective teacher feedback (Jones & Moreland, 2004; Moreland, 2004). Teachers used self checking approaches in their conversations with students to ensure students were aware of the steps undertaken and that they had completed the necessary steps in preparation for the next stage. Diagnostic questioning was also used by teachers as they sought information and clarity from students in order to move students' work forward. Teachers worked closely with students in understanding the problems they encountered and collectively made suggestions as to how best to solve the problem at hand. These kinds of teacher-student interactions enabled students to become self learners, as they became actively involved in contributing ideas during teacher-student conversations, rather than passively accepting everything the teacher suggested. This more open interaction gave students the confidence to freely share their views and ideas with their teachers.

In summative assessment, the teachers' 2005 limited assessment criteria were based only on students' tests, homework and skills assessments. In 2006 assessment broadened to include a wider range of assessment criteria. The change of pedagogy from the traditional textbook approach to the design process approach also impacted on the teachers' summative assessment criteria. The design process approach engaged students in designing, therefore, the assessment criteria became much broader to include a consideration of the designing aspects. Teachers drew up their own design assessment criteria to accommodate a broader assessment of their students' learning, and involved a detailed list of areas to be assessed. The detailed lists related specifically to the technology task at hand.

9.3.4 Impacts on Students' Learning Experiences in Technology Education

This section discusses the impact of teachers' changed teaching practices which saw students engaging in new learning experiences in technology education in 2006. These new learning experiences varied according to the extent to which each teacher implemented the newly learnt changes in his teaching practice. Therefore, students' learning experiences could be best described in three categories: first, their experiences in undertaking the design process by designing their own tasks and constructing the product as well; second, their experiences in undertaking the design process of designing their own tasks but not constructing the final product because the teachers' design was selected to be constructed; third, their experiences in undertaking the technical hands-on activities only without being involved in the design process.

The teachers who engaged students in undertaking the design process approach exposed their students to learning to design their own technology tasks as a solution through the design process technological problem-solving approach. When undertaking the design process, technical drawing came to the forefront as a required skill for sketching their solutions to a given problem. The design process enabled students to learn and use technical drawing skills and also enabled them to see the usefulness and links between their technical drawings and their defined tasks. The links gave them a framework to guide the construction of their technology tasks. This approach was showcased in the students' design folios. This contrasted with the students' technical drawings in 2005 in their exercise books, where the students' technical drawings were unrelated to their practical tasks.

The design process approach also encouraged students to become involved in self thinking, as they had to think up design ideas. This meant that most initiatives were taken by students themselves. This put them in positions to do a lot of self thinking about their design concepts and the ways to undertake and achieve the design concepts, as they had to decide on a suitable technological solution.

The design process approach also engaged students in a self reflection process as they undertook self assessment and evaluation of their technology tasks. This self reflection process contributed significantly to students undertaking the process of self thinking, engaging students in making decisions to enhance the development of their technology task to meet their required ergonomic and aesthetic expectations. Self assessment was an exercise students undertook, when they self-reflected on their finished tasks and considered areas of weakness which could be improved and strengthened. The teachers' change of pedagogy and the incorporation of the design process aspects in their teaching approaches engaged students in self thinking exercises. The 2006 students experienced active learning rather than keeping to their traditional passive learning experiences of 2005. So the students' 2005 traditional learning experiences were transformed from passive to active in 2006.

Another emerging change to teaching practice in 2006 was group work, exposing students to a new learning experience. In contrast to individual work, group work activities were undertaken officially by some students and unofficially by others. These activities enabled students to see the significance of group work in their technology tasks. Jones and Moreland (2004) state that learning does not always proceed well by students working alone, but with assistance, they can perform at a higher level. Group work enabled individual students to get help from others, especially when they got stuck with what to do next with their technology tasks. The individual contribution of ideas to the group was highlighted by students as an important contribution to group work. Students indicated that working in groups enabled their work to get done faster and more easily, as each individual contributed their ideas and played their part towards the development of their technology tasks. Dakers (2005) emphasises how learning is enhanced when students are actively involved in learning processes, that include interaction and inquiry. Thus learning in group work seemed helpful, easier and faster for group members, as they interacted to find suitable technological solutions when undertaking technology tasks.

Involving the community in classroom technology tasks was also a new learning experience for students in 2006. This emerging change in teaching practice also impacted on students' learning, as students got the community involved to assist them with the information required for undertaking their tasks. This approach drew students' attention away from teachers and textbooks as their traditional sources of knowledge or information, as was only the case in 2005. The students would never have been exposed to information within various communities of practice in society had they not undertaken activities outside their classroom settings (Dakers, 2005). Through the community learning experiences, the students were able to see the economic benefit of their technology tasks and because the technology tasks were authentic, the potential monetary benefit associated with their technology tasks was not difficult to identify, and this also provided great motivation to students. Jones (1997) pointed out that one of the reasons for teaching technology education was the economic benefits and the awareness of this for both students and commercial sectors. The students who worked on the calendar project saw the economic potential of their task and talked about the idea of getting the calendar they had designed published after it was marked so they could profit financially from their efforts. The involvement of students with the commercial community had exposed students to commercially based learning experiences.

Six teachers provided their students with hands-on experience exercises. Hence all students had the benefit of hands-on learning experiences in their technology tasks. Hands-on learning experience is one of the vital learning aspects of technology education, as it normally leads to the final outcome, which is a technological product in this case. However, some of the students missed out on the design aspects of their technology tasks, as they focussed on making only part of the product and the technical aspects of their technology tasks. This was not surprising because of the strong influence of the teachers' technical subject sub-culture teaching backgrounds (Goodson, 1985; Jones & Carr, 1992; Paechter, 1992). The hands-on learning experiences that students engaged in built their confidence and competency in using various tools for their technology tasks. While the use of computers was new learning experience for some students, the use of woodworking and metalworking tools was not new for them, as these were commonly used tools for general woodworking and metalworking tasks which these students already experienced. In addition, the hands-on learning experiences not only built students' confidence and competence in using various tools, but also gave those students who designed their own tasks the opportunity to see the link between their design tasks and the technological solution as they constructed their products. The final

outcome also provided students with something to assess, as they followed the self assessment process/exercise in evaluating their constructed product which, in itself, was a new learning experience for them in 2006.

9.3.5 Factors Hindering Teachers' Teaching Practices in Technology Education

Jones (2001) points out that those teachers who are not familiar with new curricula often revert to traditional subject sub-cultures. The Solomon Islands teachers in this study became familiar with the teaching practices for teaching the new technology curriculum. However, there were several obstacles teachers encountered during the trial which hindered them in achieving widespread change to their teaching practices. These issues were the need for uniformity, limited time, lack of working materials, lack of administrative support, and school-based assessment and examination requirements. These factors obstructed teachers in pursuing changes to their teaching practices. These issues added pressure, distracting teachers from implementing their newly learnt teaching practices. As Jones and Carr (1993) point out, often teachers who have already been in a climate of pressure may not see change as a solution but view it as a further problem. The use of the design process teaching approach fostered students' involvement in designing a solution to meet the needs or address practical problems. However, as some of the students' technology artefacts were about meeting real needs in society where quantity was important, uniformity became a main issue for consideration. Regarding this, the teachers designed the artefact themselves and then asked students to construct the artefact and so the students were not given the opportunity to experience of constructing their own designed artefact. This teacher dominated approach was undertaken so that the artefact could then be mass produced to meet quantity criteria. Thus the focus was on making a particular artefact rather than on the learning outcomes as outlined in the lesson plans.

Other factors hindering teachers during the trial were time limits and lack of money to purchase construction materials and equipment/tools. Teachers who realised time was limited, were cautious and reverted to their old style of teaching by doing the tasks for the students in order to speed things up. However, this approach to save time then deprived students of experiencing part of the design process. Teacher intervention in the form of doing tasks for students for the purpose of saving time was therefore a hindrance to effective teaching and learning, as Moreland (2003) points out teacher intervention in doing the task for students does not promote effective learning. Lack of administration support was another

hindrance to implementing effective teaching. Administrative support was highlighted by Bell (1993, 2005) and Bell and Gilbert (1996), as a crucial area for achieving a successful PD programme. The teachers in this study, who were not supported by their school administrations financially, experienced difficulties when teaching their technology tasks. Lack of construction materials, the required equipment or tools for the constructing phase of their tasks, and even lack of special classrooms (such as workshops, laboratories etc.) in some schools, limited some teachers when they taught their technology tasks. This was similar to another study as was the case in a study by Jones, Harlow, and Cowie (2004). In this study, teachers only taught the design parts without the actual building/making part. The teaching of technology was only half done, as the technological process was never completed.

The school-based assessment and examination requirements were another issue causing hindrances to effective teaching. This issue was also highlighted in some teachers' comments. This is also similar to a study by Jones, et al. (2004). School-based assessment tasks were outlined in the MoE textbooks which students were required to undertake them exactly as prescribed. Teachers asked students to use the guidelines outlined in the textbooks to help them construct their technology tasks. The teachers who picked the examination classes as the classes for this study experienced the pressure of examinations. They reverted to the traditional textbook-based approach and focused their teaching on examination preparation. Jones (2003) states that professional development is important for enhancing teachers' understanding and teaching practices of a new curriculum. It enables teachers to move forward rather than revert to traditional teaching and subject sub-culture. However, in this study, although the participant teachers' understanding of the nature of technology and technological pedagogical content knowledge had been enhanced, the preparation of students for examinations restricted teachers from moving forward. Inevitably, it affected students' learning in technology education. According to Claxton and Carr (1991), any changes enacted without the commitment of teachers may fail to convey the spirit anticipated, and instead, may result in the curriculum being implemented in only a rigid, mechanical way.

9.3.6 Effects of Effective Professional Development Programme

Bell (2005) points out that an effective professional development programme should empower teachers to try out something new by themselves, even well after the professional development process ends. However, while the PD programme was still running, some of the participant teachers applied the design process teaching approach to additional classes. This

indicated the effectiveness of the impact of the first workshop which focussed on enhancing teachers' understanding of the nature of technology and technology education and teachers' pedagogical knowledge in technology education. This initiative was the teachers' own, as they were very keen to find out how the design teaching pedagogy would work in their other classes. The outcomes reported by almost all the teachers who took up this initiative seemed to be very similar to the outcome of the observed classes. The participant teachers were impressed with their experiences in undertaking the design process teaching approach. The majority of teachers talked about reusing a design process teaching approach in the years to follow, and indicated they had no desire to revert to their old prescribed textbook-based teaching approach. As the teachers witnessed the positive impact of the design process teaching approach on students' learning, they indicated their commitment to stay with this approach for teaching future technology lessons. Interestingly, the few teachers who were unable to use the design process teaching approach because of various circumstances also indicated interest in trialling it in the future if circumstances allowed. As Bell (1993) and McGee (1997) stated, unless the teachers themselves recognise the need for change and see it as preferable to their current situation, changes will not occur. The teachers' reflection and sharing of their concepts of technology and the positive impact of their teaching experiences in technology education during the workshops enhanced and consolidated their understanding of the nature of technology. These motivated them to make changes to their classroom practices congruent with their changed views of technology and technology education – thus, confirming the notion that, as teachers' understanding of the nature of a subject was enhanced, what and how they teach that subject in the classroom would certainly be influenced as well (Jones & Moreland, 2004).

In addition, the integrity of the PD provider contributed to the teachers' motivation to voluntarily undertake changes. The belief and mutual trust teachers had in the PD provider to provide them with the relevant information and professional support needed for trialling new ideas prompted the teachers to participate willingly in the PD intervention programmes in 2006. The integrity of the PD provider was built over 11 years in the role of chairperson for the technology curriculum panel (of which some of these teachers are members), responsible for overseeing the implementation of the Design and Technology syllabus in senior secondary schools. Additionally, the PD provider also gained respect through being the instrumental person for directing the development of the new technology curriculum in the Solomon Islands. The teacher participants viewed the PD programme as a continuation of

their previous experiences with the new curriculum because the same panel members and the former chairman were still involved. The PD programme was highly respected by the teacher participants and they counted themselves privileged to be part of the PD programme. Furthermore, because the PD provider was undertaking the PD programme as part of his PhD study in technology education, he was seen as a personal resource in technology education.

9.4 Chapter Summary

This chapter presented a discussion on the key research findings beginning with the findings from the preliminary inquiry in 2005 on teachers' existing perceptions of technology and technology education and traditional classroom practices. The first part of this discussion focussed on the research findings related to the first research question. The second part of the discussion focussed on the research findings related to the third and fourth research question, presenting the impact of the 2006 PD intervention programme on teachers including changed views of technology and technology education, and their changed teaching practices. The chapter concluded with a discussion of the impact on students' learning experiences.

In 2005 the teachers' range of views of technology and indigenous technology mainly reflected the concept of artefact-related perspectives. Their view of technology education reflected the technical education concepts. These views were narrow perspectives of technology and technology education. The artefacts imported into Solomon Islands were a major factor influencing teachers' views of technology. The transition of traditional materials into the modern era was a main factor influencing teachers' views of indigenous technology. The teachers' technical education backgrounds were the main factors influencing the teachers' views of technology education. Technology education was viewed by most teachers as a crucial subject, particularly suitable for less academic students. Teachers' traditional classroom practices were conservative and dominated by the teachers. A prescribed textbook teaching approach was the main teaching approach used by most teachers, and it focussed on the use of hand tools for skills development. Students' tasks were mainly closed and focussed largely on following working procedures. The teachers' assessment practices indicated that they had limited understanding of assessments for learning and summative assessment.

The PD intervention programme seemed impacted on teachers' practices and involved changes to teachers' perceptions of technology and technology education and their classroom

practices. The impact of the three key principles (ongoing workshops, teacher reflections and sharing, and teacher support) underpinning the PD programme were effective for enhancing and building teachers' confidence to undertake changes. Teachers' views of technology changed from artefact-related perspectives to a process used for solving problems and meeting needs in society. Teachers' views of technology education changed from technical education perspectives to design activities with a problem-solving focus. The teachers' changes in teaching practices included planning more comprehensive and specific technology lessons, teaching open tasks, using a design process, encouraging student self assessment and covering a broader range of criteria in summative assessment. These changes impacted on student learning. Students changed to active learning included designing their own technological artefacts, researching information, undertaking self assessment of their task through reflection exercises, active discussions in group work, and constructing their designed artefacts. However, in some cases, the issues of uniformity, limited time and examination requirements were a hindrance to these changes. Some teachers were also motivated to use the new teaching approaches in extra classes, concurrently with the PD programme. Some planned to use it in the future as well.

CHAPTER TEN

CONCLUSIONS AND IMPLICATIONS: Towards a Professional Development Model for Technology Education Teachers in Developing Countries

10.1 Introduction

This chapter presents the conclusions related to professional development models and in-service technology education teachers in developing countries such as the Solomon Islands. In this chapter, the key issues underpinning the second research question is addressed:

2. What is an appropriate professional development model for technology education in the Solomon Islands?

The enablers and constraints to the PD in the Solomon Islands are outlined in section 10.2. A conclusion articulating a PD model for technology education in the Solomon Islands is presented in section 10.3 and the implications of this study are presented in section 10.4. Section 10.5 presents the implications for future research.

10.2 Enablers and Constraints to PD in the Solomon Islands

The PD model undertaken in the Solomon Islands has both strengths and weaknesses. This discussion first highlights the strengths and winds up with constraints to the PD model.

- *Strengths*

The two phase approach used in this PD model is seen as the strength of the model. The first phase enabled the teachers' existing perceptions and traditional classroom practices to be explored and be used as a platform for developing the PD programme. The interval between the two phases provided time for the development of the PD programme and time for the teachers to explore their new ideas and practices in the classroom. Building on the teachers' existing perceptions and traditional classroom practice approaches in the second phase highlighted and established teachers' current understandings of teacher knowledge and technological pedagogies for teaching

technology and was an effective introduction. The workshops were not just one-off after school, but whole day workshops with classroom practices integrated between workshops. The teachers were in favour of the ongoing PD approach. The ongoing PD approach provided teachers with opportunities to trial and develop ideas and to reflect on their classroom experiences and developing ideas. Teachers looked forward to the next workshops as a time to share with others their classroom experiences, as well as to learn from each others experiences. The teacher reflection and sharing components of the PD programme fostered social interaction and collaboration between teachers and this also contributed to teachers examining, and contemplating on, improving their own teaching practices. Another strength of the model were the school visits. These assisted teachers to build confidence in teaching their technology lessons. A further strength of the model was the classroom support from the PD provider. The one on one teacher support provided them with the opportunity to share their ideas on a personal level which was difficult for some teachers when in a group. The fact that the PD provider was also a local Solomon Islander helped to ease the situation for teachers to share comfortably as the PD provider was seen as one of them. As the PD provider was also seen as a resource person this was a catalyst and a bonus for teachers to get as much help as possible. Finally, this model was taken into account of the PD provider being knowledgeable about technology education and professional development - an informed facilitator is important for bringing about teacher change.

- ***Weaknesses***

One of the weaknesses of the PD programme was not enough time being given to teachers to undertake the tasks in workshop one. The PD programme undertaken in workshop one was intensive in order to get through the two days activities. All teachers commented on being rushed and not being able to grasp all the necessary ideas being presented. Another weakness was the use of overseas resource materials in the PD programme to highlight technology and technology education. The use of these resource materials were a concern to some teachers because they could not easily relate to the technology from developed countries like New Zealand. The use of these technology examples was a barrier for some teachers as they saw the examples did not match their situations where they have limited resources. Other major constraints to the success of the implementation of the ideas in the PD programme

were external factors on teachers such as the pressure of time, pressure from administrators, and pressure from external examinations. The time the PD provider spent with each teacher was relatively short – usually 2 hours for each visit. Therefore teachers who regarded the PD provider as a resource person rushed to finish their teaching in order to get as much help as possible. Teachers who faced pressure from administrators also deviated from trialing new technology teaching approaches to please their administrators. Consequently, uniformity was evident in students' tasks. External examination was another constraining factor as the examination requirements forced teachers into teaching for the examinations rather than undertaking the lessons they developed in workshop one. A further constraint to developing a comprehensive PD programme was the distance and the remoteness of the scattered islands throughout the country. Though the provider would have ideally liked to have had another round of teaching and another workshop this was not possible. However, because it was a shortened programme, the provider worked to ensure that any activity included in the workshop was important and was likely to contribute to teacher change.

Despite these constraints of the PD intervention programme, the strengths outweighed the constraints. The PD model was a successful model for a new curriculum in a developing country like the Solomon Islands.

10.3 Articulating a PD Model for Technology Education in the Solomon Islands

A professional development (PD) intervention programme is crucial for effecting teacher change, particularly for enhancing teacher knowledge in technology and technology education, and their classroom practices (Fox-Turnbull, 2006; Jones & Moreland, 2004). The findings revealed that the PD invention programme that teachers undertook broadened their understanding of technology and technology education, and also enhanced their classroom practices. The teachers broadened knowledge of the nature of technology and technology education and enhanced classroom practices also impacted on student learning in technology education (Fox-Turnbull, 2006; Jones & Moreland, 2004). The findings indicated that the impact of this PD model was effective for transforming technical education teachers into

technology education teachers. Figure 10.1 shows the PD model used for transforming the technical education teachers in the Solomon Islands into informed technology education teachers, and the extent to which it impacted teacher change and student learning.

Figure 10.1
PD Model for developing technology education teachers in developing countries

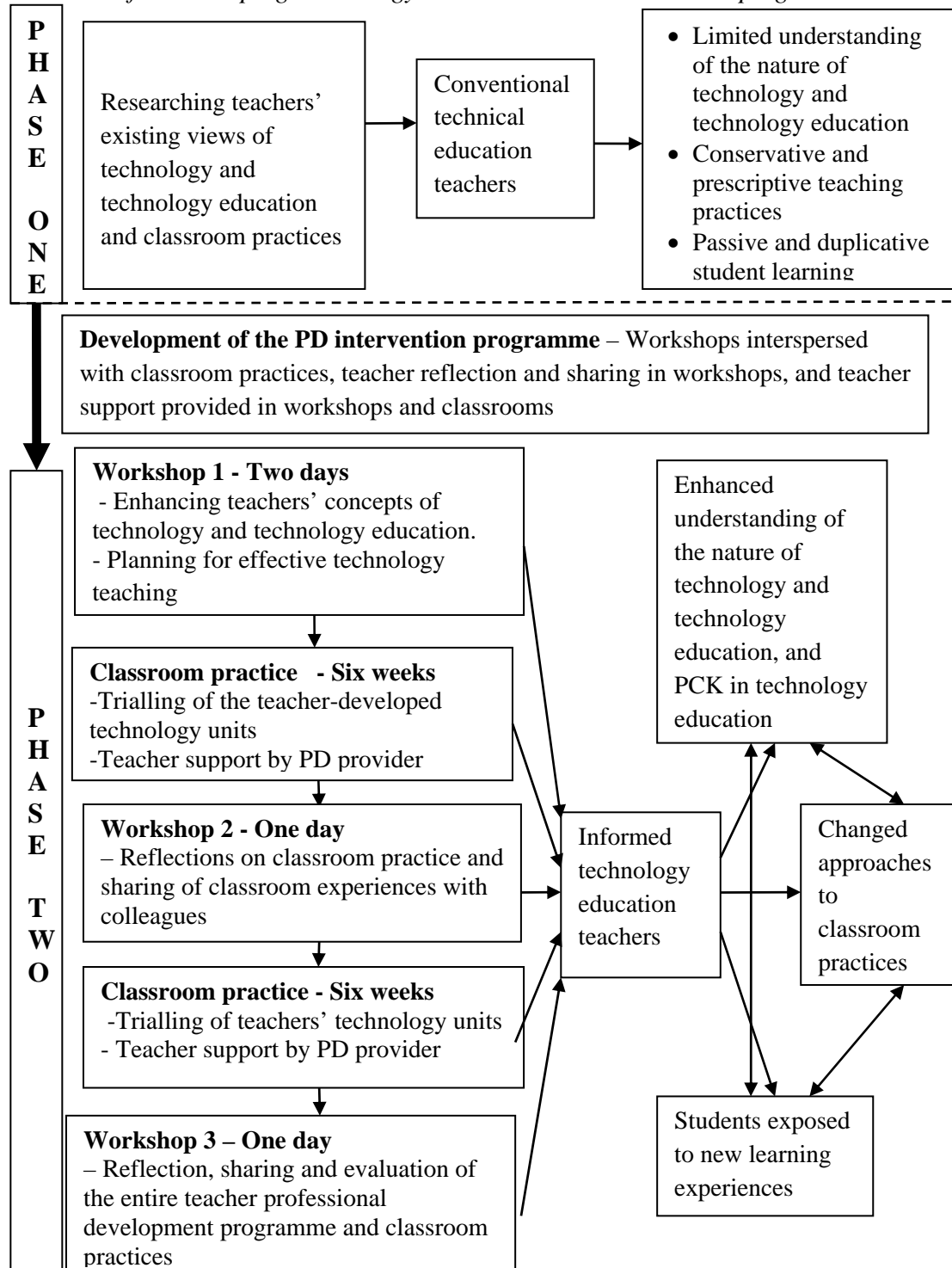

The PD model in Figure 10.1 shows a two phase approach. The first phase was a preliminary inquiry to identify teachers' existing understandings of the nature of technology and technology education, their teaching practices and the impact on student learning. The PD intervention programme was established on the basis of the findings. The PD programme focussed on enhancing the teachers' limited understandings of technology and technology education, and their conservative and prescriptive skilled classrooms practices and the passive, duplicative learning that resulted. The second phase was the PD intervention programme which was based on the key principles underpinning effective PD models, such those of an ongoing PD approach alternating the classroom practice sessions with the workshops time, for teacher reflection and sharing occur during workshop sessions, and providing teacher support during workshops and classroom practice sessions. This was a supported PD programme with the teachers' classroom practices being monitored by the PD provider. The objective of the PD intervention in phase two was to develop more informed technology education teachers (as indicated by the arrows from the workshops and classroom practice sessions). It aimed to assist these technical education teachers into becoming technology education teachers through enhancing their existing views of the nature of technology and technology education and their classroom practices. As indicated by the arrows: the informed technology teachers would firstly, develop an enhanced understanding of the nature of technology and technology education and a broader PCK in technology education; secondly, they would develop different teaching approaches from their conventional technical education classroom practices to broader technological pedagogies. Thirdly, these teachings would impact on student learning when they engaged in new learning experiences. These three features (teacher knowledge, classroom practice, and student learning) are inter-relate and influence on each other (Moreland, 1998) as shown by the double-ended arrows. They are crucial for effective planning and teaching of technology lessons in classrooms. This PD model was effective as it resulted in a successful transformation of technical education teachers into informed technology education teachers. More about the key aspects of the PD model for developing informed technology education teachers are briefly discussed next.

- ***Taking into account teachers' existing perceptions and classroom practices***

The development of this PD model was based on observations in the teachers' classrooms and gathered from teacher interviews during the preliminary enquiry. Taking teachers' existing perceptions and classroom practices into account is crucial for understanding the teachers' social positioning in terms of their knowledge and the factors that influence their understanding of technology and technology education (Jones & Carr, 1992; Jones & Compton, 1998). Understanding teachers' existing views of a subject is important. As Jones and Carr (1992) indicate, because how teachers view a subject will influence what and how they will teach it in the classroom. Therefore, the preliminary enquiry which sought to understand the teachers' existing perceptions of technology and technology education, and classroom practices was necessary as it did inform the development of this PD programme and influenced the direction and the approaches of the programme. Without an understanding of how the teachers viewed and taught technology and technology education, the development of the PD intervention programme could not be tailored to address teachers' real needs or issues. Understanding that the teachers' existing perceptions of technology and technology education were narrow and limited, and their traditional classroom practices were technical focussed, shaped the content and activities in the PD programme.

- ***Effective principles underpinning this PD intervention programme***

An effective PD programme is based on effective principles. For this PD programme they were an on-going PD approach, a teacher reflection and sharing approach, and a teacher support approach. The content focussed curriculum reform and the ongoing nature of the programmes was different from the usual centralised one-off PD programme they had previously participated in.

On-going workshop approach

Alternating workshops with classroom practice as a form of an on-going PD was in contrast to the traditional centralised one-off PD approach normally practiced in the Solomon Islands. The ongoing PD approach was necessary for enhancing teachers' knowledge and classroom practices (France, 1997; Jones 2003; Moreland, 1998). This approach not only provided teachers with additional knowledge but also with the

opportunity to use subsequent workshops to reflect on their classroom practices and share their teaching experiences with colleagues and the PD provider. Their awareness of the upcoming workshops boosted their motivation to put the theories they had learnt during the workshops into practice and consequently experience the effects of the emerging changes to their classroom practices. The follow up workshops were held after six week intervals. The first six weeks timing was adequate, as it had taken most teachers to at least halfway through their technology lessons. By the end of the second six weeks, some teachers had completed teaching their technology lessons, and others were towards the end of their technology lessons. The one day session for the second and third workshops was sufficient for teachers to reflect on their classroom practices and share their classroom experiences with their colleagues. This PD approach fostered teacher interaction through sharing, questioning and answering of questions. Interspersing workshops with classroom practices, and the six week timing interval was sufficient for teachers to have some experiences to share during the workshops. This PD approach was found to be one of the key aspects for teachers to additional assistance needed to change from technical education teachers to technology education teachers. Therefore it is an effective approach that policy-makers in the Solomon Islands need to take into account for bringing about change with technology teachers' knowledge and classroom practices.

Teacher reflection and sharing

Teacher reflection and sharing were crucial features of this PD model. Shepardson (2001) pointed out that PD programmes should “promote teacher reflection upon practices and encourage dialogue and collaboration among teachers and project staff” (p. 9). The reflection used by teachers in this research was firstly, on their existing views as they made comparisons with the scholars' views through the definitions of technology and technology education. Secondly, teacher reflection was undertaken through the evaluation process of the workshops, and thirdly, teachers reflected on their classroom practices as they shared experiences with colleagues in the two last workshops. Reflection assisted teachers to see what they were doing in their classrooms and to assess their shortfalls and strengths, and to plan for improvement in future developments (Bell, 1993). The aspect of sharing their classroom experiences was seen by teachers as an opportunity to learn from each other through reflection and

social interaction (Shepardson, 2001). Teachers learned about tacit knowledge embedded in practice as they reflected on their own and learned from others classroom practice experiences, and this was strengthened through social interaction and collaboration which has a role in improving teaching practices (Dana & Hoppey, 2008). Therefore, undertaking a PD programme that encouraged teacher reflection, social interaction and collaboration fostered a strong professional learning community of teachers working together to examine and improve their teaching practice (Borko, 2004). Sharing and interaction time was highly regarded and appreciated by most teachers as indicated in their request for more sharing time in the next workshops.

Teacher support

Providing teacher support was also a crucial feature of the PD model for the in-service technology education teachers in the Solomon Islands. Usually in-service programmes in the Solomon Islands use a centralised, one-off PD approach, so the provision of classroom support for teachers during curriculum implementation in classrooms is never considered. Therefore, the inclusion of teacher support in this PD model was a new experience for these teachers which they really appreciated. Teacher support is crucial for developing teacher confidence in trialling new ideas (Jones & Moreland, 2004) as teachers move from being technical education teachers to being technology education teachers. The teachers pointed out that the personal help from the PD facilitator during the school visits was crucial for confirming or clarifying the new ideas being undertaken during classroom practice.

Professional development and curriculum reform

Professional development related to curriculum reform is also another effective approach for effecting teacher change. Desimone, Porter, Garet, Yoon, and Birman, (2002) state that professional development programmes focus on reform of any type are effective for improving teaching practice. As a result of the national curriculum reform in the Solomon Islands in 2004 and 2005, a new technology curriculum was developed, and this PD programme was based on the changes outlined in the curriculum reform. The teachers who were part of the PD programme were aware of the technology curriculum reform, and saw the need to develop their knowledge and teaching practices so that they could teach the new technology curriculum as

intended. This PD programme facilitated and supported teachers as they made changes to their existing views and classroom practices in relation to the new technology curriculum. Bell, B, (2005) and Jones and Compton (1998) affirm that curriculum reform associated with professional development is an essential step for developing effective implementation of the curriculum reforms. Basing the PD programme on the Solomon Islands national curriculum reform resulted in developing informed teachers who are now aware of the intended changes. The focus helped them to move forward and away from their traditional teaching practices and subject sub-cultures (Jones, 2001).

Taking account of the social constructivism approach to teacher learning

The social aspects of the PD intervention programme (Bell & Gilbert, 1996; Shepardson, 2001) played a crucial role in enhancing teacher knowledge in technology and classroom practices in technology education. The theoretical framework for the PD programme was based on a social constructivism view of learning. Therefore, the nature of the workshops promoted learning through social interaction, and the sharing of knowledge. During the workshops, teachers learned through reflection, interaction and collaboration (Bell, B, 2005; Bell & Gilbert, 1996; Jones, 2003; Jones & Moreland, 2004; Moreland, 2003; Shepardson, 2001) with each other and with the PD provider. The teachers' change of views of technology and technology education and classroom practices were acquired through social discourse and interaction between the teachers themselves and with the PD provider. Teachers listened to other teachers, shared their classroom experiences as they reflected on their teaching practices, and then interacted with each other through questions and discussions. Social interaction and reflection were the key approaches to teacher learning in this PD programme which provided teachers with the opportunity to construct shared knowledge in regards to understanding the concepts of technology, technology education, and appropriate teaching practices.

Focusing on enhancing teachers' understanding of the nature of technology and technology education and PCK in technology education

Enhancing teachers' understanding of technology and technology education, and PCK in technology education is crucial for teaching of technology education in the

classroom (Fox-Turnbull, 2006; Jones & Moreland, 2004; Moreland, 2003). It is crucial for student learning that teachers have a rich and flexible knowledge of the subject (Borko, 2004). The use of the range of definitions of technology and technology education described by several scholars, and the use of both the local and global context to enable teachers to understand the inter-relationship of technology and society were the approaches used to enhance teachers' understanding of the nature of technology and technology education. Teachers' understandings were enhanced as they reflected on their own views and made comparisons with the range of definitions of technology and technology education as described by different scholars. Their understanding of the nature of technology was enhanced through the use of both local and international situations to show the inter-relationship between technology and society. As teachers from developing countries like the Solomon Islands are normally exposed to imported technological artefacts, their views of technology would normally be influenced by this (Sade & Coll, 2003). However, the inclusion of technological artefacts and situations within the local contexts was crucial for balancing the teachers' understanding of technology and technology education.

The teachers' understanding of technology education was enhanced as they were exposed to a broader concept of technology education through the use of a lesson planning format that not only reflected the technical domain of learning but societal domains (Fox-Turnbull, 2006; Jones & Moreland, 2004; Moreland, 2003; Moreland, Jones & Chambers, 2001). The new lesson planning formats exposed teachers to new pedagogies and expanded their PCK in technology education. Having an understanding of technology education PCK (Jones & Moreland, 2004; Moreland, 2003) and a robust understanding of the nature of technology and technology education (Compton & Jones, 2004) is crucial for the successful implementation of the technology curriculum in the classroom as intended. The findings revealed that as teachers' understanding of the nature of technology and technology education and PCK of technology education were enhanced, their classroom practices were more effective and these impacted positively on student learning (Jones, Mather & Carr, 1995; Moreland, 2003).

Use of a locally based facilitator

The use of a locally based facilitator brings credibility and trustworthiness to the PD programme. The PD provider of this study was not an outsider or a foreigner to the PD participants, but a local Solomon Islander, and a former chairperson of the technology curriculum panel of which most of these teachers were members. A locally based facilitator had a sound understanding of the in-service teacher participants, as well as the local setting in which the PD programme was undertaken. The use of informed facilitators in PD programmes has been found to be effective for enhancing teachers understanding of technology education and technology curriculum (Jones, 2003; Moreland, 2003).

Finally, this thesis argues that developing a well structured PD programme based on the characteristics discussed above effectively helped teachers to develop robust concepts of technology and technology education. It assists with technical education teachers and convinces them to become technology education teachers. The technical education teachers in the Solomon Islands who were part of this PD intervention programme now have a broader understanding of technology and technology education, have more effective technology teaching approaches, and are in a better position to teach the new technology curriculum as intended.

10.4 Implications of the Research Findings

This section discusses the implications of this study. The PD intervention model used in this study has several implications. Firstly; there is possibility of wider use of this model for developing technology teachers throughout the Solomon Islands. Secondly, there are implications for use of basic material resources within localised contexts for enhancing teachers' understanding of the nature of technology and teaching of technology education. Thirdly, there are implications for school administrators, fourthly, for pre-service technology teacher educators, fifthly, for teachers of other subject areas, and sixthly for an improved PD programme. These implications are discussed next in details.

- *Wider use of PD model*

This PD model worked really well for the small group of teachers who are based in Honiara, the capital of Solomon Islands. While this PD model worked really well for this small group of teachers in Honiara it also has the potential to cater for the upgrading of the rest of the technical education teachers to technology education teachers throughout the Solomon Islands. The preliminary findings revealed that the Honiara-based technical education teachers had limited understanding of the nature of technology and technology education which also influenced their classroom practices, which presumably would be the same for the rest of the technical education teachers throughout the country. The decision to undertake PD in small cluster groups was basically for its effectiveness in changing teaching practices and for providing high quality activities (Desimone et al., 2002). Therefore, a similar PD programme needs to be undertaken by the rest of the teachers through the country in order for them to teach the technology curriculum as intended.

As the Solomon Islands is made up of several islands, most of the schools throughout the country are on the scattered islands stretching over approximately 1,500 square kilometres. A similar PD programme that incorporates ongoing workshops with classroom practices, teacher reflection and sharing, and immediate teacher support during classroom practices, focussing on small groups of in-service technology teachers seems possible in the Solomon Islands. The location of schools on the scattered islands in the Solomon Islands provides a perfect setting for similar small cluster group in-service PD programmes to be undertaken in the schools within each island or between islands in the Solomon Islands. The traditional PD is held at one location for all the teachers in the country or in that province. This PD approach is in contrast to the traditional centralised one-off PD approach. It is cheaper and would not put much constraint on the national or provincial government budget, or even on the school budget, as this PD approach has short workshop days, and more classroom support with only one PD facilitator who moves around, having a greater impact on effecting teacher changes. If the traditional centralised one-off PD approach, usually at Honiara, the capital of Solomon Islands were to be used, the use of a teacher support approach in the classrooms would be difficult for teachers further away from Honiara to get immediate feedback. However, with this PD model using small

clustered groups of in-service technology teachers, teachers from schools from within each island or between islands can access a regular one-on-one base teacher support from the PD facilitators both inside and outside of their classrooms. This PD model approach will give the in-service teachers the help they need and quick feedback to enhance their teaching practices as they undertake the transition from being technical education teachers to becoming technology education teachers.

Therefore, with this PD model, the training of local PD facilitators for the PD programmes conducted throughout the country would be useful to facilitate the transition of technical education teachers to technology education teachers. Such training will provide the PD facilitators with the transition experience from being technical education teachers to technology education teachers themselves, as having an understanding of the technological concepts alone without the experience is not enough (Jones & Compton, 1998). Such experience would give the facilitators the credibility and trustworthiness to facilitate a smaller in-service teachers' PD programme. These PD facilitators would then facilitate the development of the rest of the technical education teachers in the Solomon Islands into technology education teachers. Finally, the implications stated in this section are significant factors to be considered by the stakeholders like the policy makers and aid donors in a developing country like the Solomon Islands with limited financial resources.

- *Use of basic material resources within localised contexts*

This PD model has implications for the use of basic material resources within localised contexts for enhancing teachers' understanding of the nature of technology and technology education in developing countries such as the Solomon Islands. The PD model took into account of the local contexts with limited material resources and a strong focus on technical education as technical teachers in Solomon Islands are more familiar with. The use of basic indigenous artefacts as examples of human activities in a local context presented a clear picture of the nature of technology to the teacher participants. This shows that technology teachers in developing countries can still learn about the nature of technology and technology education even with the use of basic material resources within their local contexts. Therefore, by focusing on indigenous artefacts in collaboration with common human activities within a local

context in a developing country like the Solomon Islands, the technology teachers can still see technology as a purposeful human activity (Compton & Jones, 2004) that people engaged in to improve their lifestyle.

- ***School administrators***

The findings of this study also have implications for the school administrators. An unfavourable school environment and lack of administration support were mentioned by teachers as major hindrance factors contributing to teacher's difficulty in successfully implementing technology education in the classroom (Jones, Harlow, & Cowie, 2004). If these kinds of situation continued to be faced by the Solomon Islands technology teachers, it would not be helpful for the implementation of the technology curriculum. Therefore a consideration of these issues by stakeholders such as the policy makers, school principals, heads of departments, and technology teachers is crucial for a successful implementation of the anticipated technology curriculum. This suggests that schools need to be properly equipped with technology facilities such as technology classrooms, working materials and tools, and in addition, a budget must be allocated to the technology department to successfully support the implementation of the technology curriculum.

The study has also shown that while enhancing teachers' perceptions of technology and technology education and teaching practices may seemed possible, the impact it had on these experienced teachers' change of classroom practices was problematic for some who encountered obstacles. In a developing country like the Solomon Islands with limited teaching resources, the teachers' change of classroom practices depends very much on the resource materials being provided. Limited resource materials in terms of money, working materials, equipment and tools were found to be the main hindrances to teacher change. Other hindrances were lack of administration support (as mentioned above) and examination requirements. This indicates that a supportive school environment is a crucial contributing factor to a successful implementation of technology curriculum in the classroom (Jones et al., 2004).

- ***Pre-service technology teacher educators***

While this PD model is developed for effecting teacher change in in-service technology education teachers, the content of the PD programme also has implications for training of the pre-service teachers. The subjects of the nature of technology and technology education, and PCK in teaching technology education were the focus of the PD intervention programme. These are also crucial for pre-service technology teachers to understand in order to teach the technology curriculum as intended, and thus need to be considered by the technology teacher educators who are responsible for pre-service teacher training. The study revealed that as the experienced technical education teachers have a better understanding of the nature of technology and technology education, and PCK in technology education, changes to teaching practices were also evident in their classroom practices. This indicates that understanding of the nature of technology and technology education, and PCK in technology education is also crucial for classroom practice (Jones, 2003; Jones & Moreland, 1998). Therefore, the technology teacher educators should consider both aspects for the teacher training programme of pre-serviced technology teachers which will then contribute to creating informed and empowered technology teachers to teach the technology education curriculum.

- ***Teachers of other subject areas***

The PD Model also has implications for in-service teachers of other subject areas. The on-going school-based PD programme integrated with teacher support and teacher reflection and sharing in collaboration with curriculum reform was found to be more favoured by the teachers than the traditional one-off centralised PD programmes usually undertaken by the teachers in the Solomon Islands. This PD approach with workshop sessions alternating with classroom practices provided teachers with the opportunity to get hands-on experience in undertaking emerging changes to their traditional classroom practices and used the organised workshops between the classroom practices to reflect on and share with colleagues on the benefits and shortfalls being experienced during classroom practice. This PD approach was found to be very effective in influencing teacher changes from technical education to technology education. It was easier for the technical education teachers to accept the changes as they had experienced both the benefits and the difficulties of the emerging

changes. The study revealed that teachers were in more favour of the ongoing school based PD approach undertaken in this study in enhancing their understanding of the nature of technology and technology education including the school-based support they received in their classrooms from the PD provider and the reflection and sharing sessions during the three workshops, rather than the traditional centralised one-off workshops. This PD model would also be effective in enhancing teacher change in other subject areas, especially in moving teachers from their traditional dissemination/transmission classroom practices to a more innovative and creative classroom practices. As teachers talked positively about the on-going school-based PD approach with the teacher support provided and teachers' reflection and sharing, this PD model should be considered by the curriculum officers and policy makers for effecting teacher change in other subject areas.

- ***An Improved PD Programme***

This PD model also has implications for improvement. The time factor allocated for workshops one and two was indicated by the teachers in their evaluation as too short. Therefore, this is one area that needs improvement. Rather than having two days of intensive workshop as in workshop one, another day could be added to make it three days in workshop one and two days in workshop two. Adding an extra day to both workshops would reduce the intensiveness of the workshops and give teachers more time for reflecting and sharing. Hence, it will foster more social interaction and collaboration which will enhance teacher learning.

Another area required change is the use of foreign resource materials to enhance teachers' concepts of technology and technology education. The use of locally produced resource materials could replace the foreign resource materials particularly the videos used for this PD programme. Locally produced videos taking into account of the local context could be used to enhance teachers' concepts of technology and technology education in the Solomon Islands context. Indigenous technological concepts could be used which teachers are more familiar with than the foreign technological concepts. This would also give teachers the confidence to use indigenous resource materials for teaching technology in schools where there are limited resource materials.

10.5 Implications for Future Research

This section discusses the areas in need of future research to follow up this research study. This research examined teachers' existing views of technology and technology education and traditional teaching practices. A structured PD programme was employed, aimed at enhancing the teachers' understandings of technology and technology education and classroom practices and was proven to be effective. To further develop teachers' understanding of effective teaching of technology education and students' effective learning, the following research needs to be undertaken:

- Further research in enhancing teachers' understanding in identifying generic and specific learning outcomes and exploring the operationalising of the learning outcomes in their teaching practices of specific technology areas in technology education;
- Further research in enhancing the teachers' concepts in specific technological key learning areas and exploring teachers' experiences in technological practices in these specific key technological areas in technology education within a social constructivist and socio-cultural context;
- Further research in enhancing students' concepts of technology and technology education, and examining students' capability in undertaking technological tasks in specific key learning areas in technology education; and
- Further research in enhancing students' learning in technology education by examining and enhancing the teachers' formative interactions in the classrooms.

Finally, this study concludes that the professional development model that was developed and used in this study for enhancing traditional technical education teacher to become informed technology education teachers in the Solomon Islands was found to be effective. Consequently, teacher changes were evident in the areas of the teachers' understanding of the nature of technology and technology education, and also with changes to their classroom practices. It also impacted on student learning in technology education. Therefore, this thesis argues that a PD programme that took into account the localised contexts and settings, the enhancement of teachers' existing views, and the development of best classroom practices would positively influence teacher knowledge, classroom practices, and student learning.

REFERENCES

- Adams, J. (1993). *Flying buttresses, entropy and o-rings: The world of engineers*. Cambridge, MA: Harvard University Press.
- Anning, A. (1994). Dilemmas and opportunities of a new curriculum: Design and Technology with young children. *International Journal of Technology and Design Education* 4, 155–177.
- Banister, P., Burman, E., Parker, I., Taylor, M., & Tindall, C. (1994). *Qualitative methods in psychology: A research guide*. Buckingham, UK: Open University Press.
- Bell, B. (1993). *I know about LISP but how do I put it into practice? Final report of the learning in science project (Teacher development)*. Hamilton, New Zealand: Centre for Science and Mathematics Education Research, University of Waikato.
- Bell, B. (2005). *Learning in Science. The Waikato Research*. London: Taylor & Francis Group. RoutledgeFalmer
- Bell, B., & Gilbert, J. (1996). *Teacher development: A model from science education*. London: Falmer Press
- Bell, B., Osborne, R., & Tasker, R. (1985). Finding out what children think. In R. Osborne & P. Freyberg (Eds.), *Learning in science* (pp.151-165). Auckland, New Zealand: Heinemann.
- Bell, J. (1999). *Doing your own research project* (3rd ed.). Buckingham, UK: Open University Press.
- Bell, J. (2005). *Doing your own research project* (4th ed.). Buckingham, UK: Open University Press.
- Bentley, D., & Watt, M. (1994). *Primary science and technology*. Buckingham, UK: Open University Press.
- Biddulph, F., & Carr, K. (1999). Learning theories and curriculum. *Teachers and curriculum*, 3. Hamilton, New Zealand: University of Waikato: Leaders Press. 1-9.
- Black, P.J. (1994). *Technology in the school curriculum*. Papers from Science, Mathematics and Technology (SMT) Education in OECD countries.
- Borko, H. (2004). Professional development and teacher learning: Mapping the Terrain. *Educational Researcher*, 33 (8), pp. 3–15.
- Bouma, G.D. (1996). *The research process* (3rd ed.). Melbourne: Oxford University Press.
- Brown, J.S., Collins, A., & Duguid, P. (1989). Situated cognition and the culture of learning. *Educational Researcher*, 18(1), 23-42. ISSN 0013-189X
- Bryman, A. (2001). *Social research methods*. UK; Oxford University Press.
- Burgess, R.G. (1982). Approaches to field research. In R.G. Burgess (1982) *Field research: A spurce book and field manual*. (pp. 1-11). London: George Allen and Unwin.
- Burns, J. (1992). Student perceptions and implications for an empowering curriculum. *Research in Science Education*, 22, 72-80.
- Burns, J. (1997). Technology - intervening in the world. In J. Burns (Ed.), *Technology in the New Zealand curriculum: Perspective and practice* (pp. 15-30). Palmerston North, New Zealand: Dunmore.
- Burns, R. B. (2000). *Introduction to research methods* (4th ed.). Pearson Education Australia.

- Claxton, G., & Carr, M.D., (1991). Understanding change: The personal perspective. In B. Bell (Ed.), *SAME papers* (pp. 1-14). Hamilton, New Zealand: Longman Paul.
- Cannell, C.F. & Kahn, R.L. (1968). Interviewing. In G. Lindzey, & E. Arison, E. (Eds). *The handbook of social psychology, vol.2, Research Methods* (pp.526-595). New York: Addison-Welsey,.
- Cohen, L., & Manion, L. (1994). *Research methods in education* (4th ed.). London: Croom Helm.
- Cohen, L., Manion, L., & Morrison, K. (2000). *Research methods in education* (5th ed.). London: Routledge Falmer Press.
- Cohen, L., Manion, L., & Morrison, K. (2007). *Research methods in education* (6th ed.). London: Routledge Falmer Press.
- Compton, V., & Jones, A. (1998). Reflecting on teacher development in technology education: Implications for future programmes. *International Journal of Technology and Design Education* 8, 151 - 166,
- Compton, V., & Jones, A. (2004). The nature of technology: Briefing paper prepared for the New Zealand. Retrieved on January 24, 2006 from http://www.tki.org.nz/curriculum/whats_happening/index_e.php
- Compton, V., & Harwood, C. (2003). Enhancing technological practice: An assessment framework for technology education in New Zealand. *International Journal of Technology and Design Education* 13: 1 - 26,
- Compton, V., & Harwood, C. (2005). Progression in Technology Education in New Zealand: Components of Practice as a Way Forward. *International Journal of Technology and Design Education* 15: 253–287,
- Compton, V. & Harwood, C. (2007). Moving from technical to technology education. Why is it so hard? *TENZ Conference 2007 Proceedings*, pp.105-115.
- Crawley, F.E., & Salyer, B.A. (1995). Origins of life: Science teachers' beliefs underlying curriculum reforms in Texas. *Science Education*, 79. 611-635.
- Creswell, J.W. (1998). *Qualitative inquiry and research design: Choosing among five traditions*. Thousand Oaks: Sage Publications.
- Creswell, J.W. (2003). *Research design: Qualitative and quantitative research approaches* (2nd ed). California: Sage Publications, Inc.
- Curriculum Development Centre (1983). Policy documents relating to Solomon Islands education; *Education policy 1975-1979*: Honiara, Solomon Islands: CDC.
- Custer, R.L. (1995). Examining the dimensions of technology. *International Journal of Technology and Design Education*, 5(3), 219-244.
- Cutcliffe, S.H. (1981). Technological literacy for non-technologist: In *Proceedings of the technology education symposium II*. Menomonie, WI: University of Wisconsin-Stout.
- Dakers, J. (2005). Creating communities in technology education – introduction to the Special Issue. [Editorial] *International Journal of Technology and Design Education* 15.1–4.
- Dakers, J. (2005). Technology education as solo activity or socially constructed learning. *International Journal of Technology and Design Education* 15. 78 – 89.
- Dana, N.F. & Hoppey, D.Y. (2008). *The Reflective educator's guide to professional development – Coaching inquiry-oriented learning communities*. Thousand Oaks, California: Corwin Press.

- Denscombe, M. (1995). Teachers as an audience for research: the acceptability of ethnographic approaches to classroom research, *Teachers and teaching: Theory and practice*, 1(2), 173-192.
- Denscombe, M. (1998). *The good research guide: For small-scale social research project*. Buckingham: Open University Press.
- Denzin, N.K. (1970). *The research act: A theoretical introduction to sociological methods (2nd ed.)*. New York: McGraw-Hill.
- Desimone, L.M., Porter, A.C., Garet, M.S., Yoon, K.S., and Birman, B. F. (2002). Effects of professional development on teachers' instruction: Results from a three-year longitudinal study. *Educational Evaluation and Policy Analysis*, 24, 81-112.
- DeVore, P.W. (1980). *Technology: An introduction*. Worcester, MA: Devis.
- de Vries, M. (2005). *Teaching About Technology: An Introduction to the Philosophy of Technology for Non-philosophers*. The Netherlands: Springer.
- de Vries, M.J. & Tamir, A. (1997). Shaping concepts of technology: What concepts and how to shape them. *International Journal of Technology and Design Education* 7: 3-10.
- Ding, B. (2009). Technology and Vocational Education in India. In A.T.Jones & M.J.de Vries (eds). *International Handbook of Research and Development in Technology Education* (105-116). Sense Publishers.
- Dugger, W. (2005). Twenty years of educational standards for technology education in the states *PATT 15 Conference*. Retrieved on August 10, 2005 from <http://www.iteaconnect.org/Conference/PATT15/Dugger.pdf>
- Dyrenfurth, M.J. (1984). Literacy for technological world. *Information Series No. 266*. Columbus, Ohio, USA: The National Centre for Vocational Education.
- Dyrenfurth, M.J. (1990). The urgency of the situation: *IDES Proceedings*: (pp. 11-35). Edinburgh: Scottish Consultative Council on the Curriculum (SCCC).
- Engelbrecht, W., Ankwicz, P. & De Swardt, E. (1998). Technology education in South Africa Since 1998: A Shift to Decentralised Continuous Professional Teacher development Paper presented at the PATT – 15 Technology education and research – Twenty years in retrospect, San Antonio.
- Eisner, E. (1994). *The educational imagination* (3rd ed). New York: Macmillan.
- Fox-Turnbull, W. (2006). The influences of teacher knowledge and authentic formative assessment on student learning in technology education. *International Journal of Technology and Design Education*, 16:53–77.
- France, B. (1997). *Realising the Technology Curriculum: Professional Development in Biotechnology Education*. University of Waikato, Unpublished PhD thesis.
- Fullan, M. (1982). *The meaning of educational change*. New York: Teachers' College Press.
- Gardner, P. (1994). The relationship between technology and science: Some historical and philosophical relations. Part 1. *International Journal of Technology and Design Education*, 4: 123-153.
- Ginner, T. (2007). Implementing technology education: Not just a question of excellent steering documents. *TENZ Conference 2007 Proceedings*, pp.1-7.
- Goodson, I.F. (1991). Teachers' lives and education research. In I.F. Goodson & R. Walker (Eds.). *Biography, identity, and schooling: Episodes in educational research* (pp.137-149). London: Falmer.
- Goodson, I.F. (1985). *Social histories of the secondary curriculum*. Lewes: Falmer Press.

- Groves, W.C. (1939). *Report on a survey of education in the British Solomon Islands Protectorate*. Melbourne, Australia: Education Department of Victoria.
- Guba, E.G., & Lincoln, Y.S. (1989). *Fourth generation evaluation*. Newbury Park, CA: Sage Publication.
- Guba, E.G., & Lincoln, Y.S. (1994). Competing paradigms in qualitative research. In N.K. Denzin & Y.S. Lincoln (Eds.). *Handbook of qualitative research* (pp. 105-117). Thousand Oaks, CA: Sage Publications.
- Haig, M. (1995). The achievement in Science: Developing science in the New Zealand curriculum. In A. Jones (Ed.). *SAMEpapers 1995*, (pp. 45 – 74) Hamilton, New Zealand; CSMTER, University of Waikato.
- Hansen, R., & Froelich, M. (1994). Defining technology and technology education: A crisis, or cause for celebration? *International Journal of Technology and Design Education*, 4: 179-206.
- Harker, R. (1999). *Research methods, unit four: Research design and methodologies*. Palmerston North, New Zealand: Massey University College of Education.
- Hennessy, S. (1993) Situated cognition and cognitive apprenticeship: Implications for classroom learning. *Studies in Science Education* 22: 1-41.
- Hodson, D. & Hodson, J. (1998). From constructivism to social constructivism: a Vygotskian perspective on teaching and learning science. *School Science Review*, 7: 33-41.
- Honan, M., & Harcombe, D. (1997). *Solomon Islands*. Victoria, Australia: Lonely Planet.
- International Technology Education Association (2000). *Standard for technological literacy*. Virginia: International Technology Education Association.
- Jarvis, T., & Rennie, L. (1996). Perceptions about technology held by primary teachers in England. *Research in Science and Technology Education*, 14: 43-54.
- Johnson, J.R. (1989). *Technology: A report of the project 2061 phase 1 technology panel*. Washington, DC: American Association for the Advancement of Science.
- Johnson, S.D. (1992). A Framework for technology education curricula which emphasizes intellectual processes. *Journal of Technology Education*, 3(2). 26-36.
- Jones, A. (In press) The development of technology education internationally. In A. Jones & M. de Vries (Eds.). *International Hand book of Research and Development in Technology Education* (pp. 1- 5). Rotterdam Sense.
- Jones, A. (1997). Technology education in the New Zealand curriculum. In J. Burns (Ed.). *Technology in the New Zealand curriculum: Perspective and practice* (pp. 46-59). Palmerston North, New Zealand: Dunmore.
- Jones, A. (2001). Theme issue: Developing research in technology education. *Research in Science Education*, 31, 3-14.
- Jones, A. (2003). Developing a national curriculum in technology for New Zealand. *International Journal of Technology and Design Education*, 13, 83-99.
- Jones, A. (2005). The developing field of technology education in New Zealand: The last twenty years. *PATT Conference Proceedings*. PATT – 15; ITEA. Retrieved on August 10, 2005 from <http://www.iteaconnect.org/PATT15/Jones.pdf>.
- Jones, A., & Carr, M. (1992). Teachers' perceptions of technology education: Implications for curriculum innovation. *Research in Science Education*, 22, 230-239.

- Jones, A., & Carr, M. (1993). *Towards technology education. Vol. 1: Working papers of the learning in technology project*. University of Waikato, Hamilton, New Zealand: Centre for Science, and Mathematics Education Research.
- Jones, A., & Compton, V. (1998). Towards a model for teacher development in technology education: From research to practice. *International Journal of Technology and Design Education*, 8, 51–65.
- Jones, A., Mather, V., & Carr, M. (1995). *Issues in the practice of technology education, Vol 3*, Hamilton, New Zealand: Centre of Science and Mathematics Education Research, University of Waikato.
- Jones, A., Harlow, A., & Cowie, B. (2004). New Zealand teachers' experiences in implementing the technology Curriculum. *International Journal of Technology and Design Education*, 14, 121–40.
- Jones, A., & Moreland, J. (2004). Enhancing practicing primary teachers' pedagogical content knowledge in technology. *International Journal of Technology and Design Education* 14, 121–140.
- Kerre, B. W. (1994). Technology education in Africa. In D. Layton (Ed) *Innovations in science and technology education*. Vol.V. UNESCO Publishing
- Kii, L. (1994, September). *Issues and problems pertinent to our education system*. Paper presented at an education summit organised by the Ministry of Education and Training. Honiara, Solomon Islands.
- Kitwood, T.M., (1977). *Values in adolescent life: Towards a critical description*, unpublished dissertation, School of Research Education, University of Bradford.
- Kudu, D. (2001, July). *Population trends and their impacts on human resource development and planning*; A paper presented at the leaders seminar. Ministry of National Planning and Human Resources Development. Retrieved on August 25, 2001 from <http://www.peoplesfirst.net.sb/General/Population%20Seminer.htm>
- Lather, P. (1992). Critical frames in educational research: Feminist and post structural perspectives. *Theory into Practise*, 2, 87-99.
- Lave, J. (1991). Situated learning in communities of practices. In L.B. Resnick, J.M. Lavine, & S.D. Teasley (Eds). *Perspectives on socially shared cognition* (pp. 63-82). Wasignton DC: American Psychological Association.
- Layton, D. (1993). *Technology challenge to science education*. Buckingham, UK: Open University Press.
- Lansing, J. B., Ginsberg, G.P., & Braaten, K. (1961). *An investigation of response error*. Chicago IL: Bureau of Economic and Business Research, University of Illinois.
- Liligeto, A.G. (2001). *Perceptions of technology and technology education in Solomon Islands and Fiji*. Unpublished PhD thesis. The University of Waikato, Hamilton: New Zealand.
- Lux, D.G. (1983, April). *Science and technology: A new alliance*. A paper presented at the American Industrial Arts Association Annual Conference. Milwaukee, Wisconsin: USA.
- Maykut, P., & Morehouse, R. (1994). *Beginning qualitative research*. London: Falmer.
- Mawson, B. (2007). Factors affecting learning in technology in the early years at school. *International Journal of Technology and Design Education* 17, 253–269.

- McComick, R. (1992). The evolution of current practice in technology education. In R. McComick, P. Murphy, and M. Harrison (Eds). *Teaching and learning technology*. Workingham, UK: Addison- Wesley, Open University.
- McComick, R. (1997). Conceptual and procedural knowledge. *International Journal of Technology and Design Education*, 7, 141-159.
- McCormick, R., Murphy, P., & Hennessey, S. (1994). Problem solving processes in technology education: A pilot study. *International Journal of Technology and Design Education*, 4, 5-34.
- McGee, C. (1997). *Teachers and curriculum decision-making*. Palmerston North, New Zealand: Dunmore.
- McGee, C., Jones, A., Bishop, R., Cowie, B., Hill, M., Millar, T., Harlow. A., Oliver, D., Tiakiwai, S., Mackenzie, K., (2002). *Curriculum stocktake: National school sampling study. Teachers' experiences in curriculum implementation: General curriculum, Mathematics and Technology*. School of Education, University of Waikato, Hamilton.
- McRobbie, C.J., & Tobin, K. (1995). Restraints to reform: The congruence of teacher and student actions in a chemistry classroom. *Journal of Research in Science Teaching*, 32(4), 373-385.
- McRobbie, C.J., Ginns, I.S., & Sarah, J.S. (2000). Pre-service primary teachers' thinking about technology and technology education. *International Journal of Technology and Design Education*, 10, 81-101.
- Miles, M.B., & Huberman, M.A. (1994). *Qualitative data analysis: Expanded sourcebook*. Thousand Oaks, CA: Sage Publication.
- Ministry of Education (1974). *Education for What? CDC*, Honiara, Solomon Islands: SIG.
- Ministry of Education (1995). *Technology in the New Zealand curriculum*. Wellington, New Zealand: Learning Media.
- Ministry of Education. (2004). *Education Strategic Plan 2004-2006*, (2nd ed.). Honiara, Solomon Islands; SIG.
- Ministry of Education. (2004). *Education for Living: Draft policy on Technical, Vocational Education and Training*. Honiara, Solomon Islands: SIG.
- Ministry of Education. (2005). *Technology syllabus - Draft copy*. Honiara, Solomon Islands; SIG.
- Ministry of Education. (2007). *The New Zealand Curriculum*. Retrieved on November 18, 2008 from <http://nzcurriculum.tki.org.nz>
- Merriam, S.B. (1988). *Case study research in education: A qualitative approach*. San Francisco, CA: Jossey-Bass, Inc.
- Mitcham, C. (1994). *Thinking through technology*. Chicago, IL: University of Illinois Press.
- Moreland, J. (1998). *Technology education teacher development: The importance of experiences in technological practice*, Unpublished M.Ed Thesis. University of Waikato, Hamilton, New Zealand: CSTER.
- Moreland, J. P. (2003). *Becoming Effective Technology Teachers*. Unpublished PhD thesis, University of Waikato, Hamilton, New Zealand.

- Moreland, J. P. (2004). Putting students at the centre: Developing effective learners in primary technology classrooms. *Set: Research information for Teachers. 1*, (37-43) University of Waikato.
- Moreland, J., Jones, A., & Chamber, (2001). Enhancing student learning in technology through enhancing teacher formative interaction. *Set: Research information for Teachers. No. 3.* (pp. 16-19) University of Waikato.
- Moreland, J., Jones, A. & Northover, A. (2001). Enhancing teachers' technological knowledge and assessment practices to enhance student learning in technology: A two-year classroom study. *Research in Science Education* 31: 155-176, *Kluwer Academic Publishers. Netherlands.*
- Natarajan, C. & Chunawala, S. (2009). Technology and Vocational Education in India. In A.T.Jones & M.J.de Vries (eds). *International Handbook of Research and Development in Technology Education* (105-116). Sense Publishers.
- Naughton. J. (1992). What is technology? In R. McCormick, C.W.A.Newey, & J. Sparkes, (Eds), *Technology for technology education* (pp. 3-10). London: Open University.
- Northover, B.A. (1997). *Teacher development in biotechnology: Teachers' perceptions and practice.* Unpublished M.Ed thesis, University of Waikato, Hamilton, New Zealand.
- Pacey, A. (1983). *The culture of technology.* Oxford, UK: Blackwell.
- Paechter, C. (1992). Subject subcultures and the negotiation of open work: conflict and co-operation in cross-curricular coursework. In McCormick, R., Murphy, P. and Harrison, M. (Eds.), *Teaching and learning technology.* (pp. 279-288) Workingham: Addison-Wesley, Open University Press.
- Petrina, S. (1998). Multi-disciplinary technology education. *International Journal of Technology and Design Education*, 2, 103-138.
- Petrina, S. (2000). The politics of technological literacy. *International Journal of Technology and Design Education* 10, 181-206.
- Rasinen, A. (2003). An analysis of the technology education curriculum of six countries. *Journal of Technology Education* 15: Retrieved on August 6, 2005, from <http://www.scholar.lib.vt.edu/ejournals/JTE/v15n/rasinen.jtml>.
- Rennie, L. (1987). Teachers' and pupils' perceptions of technology and the implications for curriculum. *Research in Science and Technology Education*, 2, 121-133.
- Reason, P., & Rowan, J. (1981). *Human inquiry: A source book of new paradigm research.* Chichester, UK: Wiley
- Resnick, L.B. (1991). Shared cognition: Thinking as social practice. In L.B. Resnick, J.M. Levine, and S.D. Teasley, (Eds.), *Perspectives on socially shared cognition.* Washington, DC: American Psychological Association.
- Robottom, I., & Hart, P. (1993). Towards a meta-research agenda in science and environmental education. *International Journal of Science Education*, 15(5), 591-605.
- Rodi, F., & Davy, J. (2002). *A handbook for curriculum developers.* Honiara, Solomon Islands: CDC.
- Rogoff, B. (1990). *Apprenticeship in thinking: Cognitive development in social context.* New York: Oxford University Press.

- Sade, D. (2002). *Primary teachers' perceptions of technology and technology education: Implications for technology curriculum*. Unpublished M.Ed Thesis. University of Waikato, Hamilton, New Zealand: CSTER.
- Sade, D. & Coll. R. K., (2003). Technology and technology education: Views of some Solomon Island primary teachers and curriculum development officers. *International Journal of Science and Mathematics Education* 1: 87-114.
- Selltiz, D., Jahoda, M., Deutsch, M., & Cook, S.W. (1962). *Research methods in social relations*. (2nd ed.) New York: Holt, Rinehart & Winston.
- Shepardson, D. P. (2001). *Assessment in science: A guide to professional development and classroom practice*. Boston: Kulwer Academic Publisher.
- Shulman, L. S. (1999). Knowledge and teaching; In J. Leach, & B. Moon, (Eds). *Learners and pedagogy*. (pp. 61-77) London: The Open University.
- Sinclair, J.McH., & Coultard, R.M. (1975). *Towards and Analysis of Discourse: The English use by teachers and students*. London: Oxford University Press
- Solomon Islands Training College (1981). *The development of education in the Solomon Islands: Diploma in Education, Parts D and E*. Honiara, Solomon Islands: SITC.
- South Pacific Board for Educational Assessment, (2002). *Pacific Senior Secondary Certificate Design Technology 1&2*. Suva, Fiji: SPBEA.
- Staudenmaier, J. (1985). *Technology's storytellers: Reweaving the human fabric*. Cambridge, Massachusetts. The society for the history of technology and the MIT Press.
- Steven, A. (2009). Technology and Vocational Education in India. In A.T.Jones & M.J.de Vries (eds). *International Handbook of Research and Development in Technology Education* (105-116). Sense Publishers.
- Symington, D.J. (1987). Technology in the primary school curriculum: Teachers' ideas. *Research in Science and Technology Education*, 2, 167-172.
- Taba, H. (1962). *Curriculum Development: Theory and Practice*, New York; Harcourt, Brace and World.
- Taylor, R. W. (1949). *Basic Principles of Curriculum and Instruction*, Chicago IL; University of Chicago Press.
- The Cognition and Technology Group at Vanderbilt (1990). Anchored instruction and its relationship to situated cognition. *Educational Researcher*, 19(6), 2-10.
- University of the South Pacific, (1998) *Technology A & B*. Suva, Fiji: USP.
- University of Waikato (2005). *Handbook on Ethical Conducts in Research* Hamilton, New Zealand: CSTER
- Van den Akker, J.J. (1988). The teacher as learner in curriculum implementation. *Journal of Curriculum Studies*, 1: 47 – 55.
- Vygotsky, L. S. (1978). *Mind in society: the development of higher psychological*. Edited by M. Cole, V. J. Steiner, & S. Scribner. London: Harvard University Press.
- Williams, P.J. (1992). Technology as a discipline. In *ACET 10th Biennial National conference* proceedings (pp. 83-88). Gold Coast, Queensland, Australia.
- Williams, J.P. (2005). Technology education in Australia: Twenty years in retrospect. *PATT 15 Conference* Retrieved on August 10, 2005 from <http://www.iteaconnect.org/Conference/PATT/PATT15/Williams.pdf>

- World Bank Report (1993, May). Post-secondary education and the labour market: Issues and options. *Pacific islands series*, 5(2). Solomon Islands. Pacific Regional Post Secondary Education Study.
- Wright, T. (1996, January). *Technology education: A hands on / minds on experience*. Paper presented at the ACET conference. Tasmania, Australia.
- Wright, R.T., & Lauda, D.P., (1993). Technology education – a position paper. *The Technology Teacher*, 52, 3-5.
- Yin, R.K. (1994). *Case study research: Design and methods (2nd ed.)*. Applied social research methods series volume 5. Thousand Oaks, CA: Sage Publications.
- Yin, R.K. (2003). *Case study research: Design and methods (3rd ed.)*. Applied social research methods series volume 5. Thousand Oaks, CA: Sage Publications.
- Zuga, K.F. (1997). An analysis of technology education in the United States based upon an historical overview and review of contemporary curriculum research. *International Journal of Technology and Design Education* 7, 203 – 217.

Appendices

- Appendix A- The research study plan timeline
- Appendix B - Application for ethics approval
- Appendix C - The initial interview questions
- Appendix D - Observation of technology teaching approaches Format
- Appendix E – Letter to the Ministry of Education
- Appendix F – Letter of consent
- Appendix G – Teachers’ backgrounds
- Appendix H – Screws and screwing notes
- Appendix I – Technical drawing
- Appendix J – Claw hammer notes
- Appendix K – Raymond’s photocopied notes
- Appendix L – School backgrounds
- Appendix M – Survey questionnaires
- Appendix N – Technology definitions

Appendix A

The Research Study Plan Timeline

March 2005– August 2005

Develop a full research plan

Review relevant literatures related to the research topics and start writing the preliminary sections of the thesis.

September – November 2005

Phase 1- Preliminary inquiry

- Arrange research procedures with the Ministry of Education.
- Visit schools to get the schools permissions and teacher consents.
- Preliminary interviews, and classroom practices observations as data collections

December 2005 – June 2006

- Analysing and writing up of the research findings of the preliminary inquiry
- Developing the teacher professional development programmes for technology education teachers

July – November 2006

Phase 2 - Professional Development and Classroom practice

- Implement the first two days of teacher development programme
- Observation of classroom practices and data collection
- Implement the second two days teacher development programme
- Observation of classroom practices and data collection
- Final day of teacher development - wrap up and reflections

December 2006 – February 2009

- Analysing and writing up of the research findings of phase 2 of the research inquiry
- Continue with literature reviewing and writing
- Writing up of the Discussion and the final sections of the thesis
- Completing and editing of the full Thesis
- Submit the thesis at the end of February 2008

Appendix B

The University of Waikato

Application for Ethics Approval

Human Research Ethics Committee

1 Title of Project

Professional Development in Technology Education in the Solomon Islands

2 Researcher(s) and Contact Details

a Name of applicant

David Sade

b Program of study (if applicable)

PhD Thesis

c Department/Centre/Unit

STER Centre

d Phone number

(64) 7 838 4466 ext 8923

e Qualifications

BEd, PGD in Technology Education, MEd

f Other personnel

Dr. Judy Moreland – Chief Supervisor

Professor Alister Jones – Second supervisor

3 Description of Project

a Justification

The aims of this research study are to explore the effectiveness of a professional development programme in enhancing 8 - 10 secondary school technology education teachers' concepts of technology and technology education and its impact on their teaching practices in the classroom. This study is very important because its outcome will have significant benefits to several stakeholders who are involved in technology education curriculum development in the Solomon Islands, either directly or indirectly.

- ❖ Firstly, it will provide technology education teachers with relevant information, which will enhance their concepts of technology and technology education as well as their teaching of the technology curriculum. Hence, it will improve students learning in technology education
- ❖ Secondly, it will provide curriculum planners with information to direct their planning and provide on-going support to teacher professional developments in the Solomon Islands.
- ❖ Thirdly, it will provide policy makers with information for policy of development to assist with effective curriculum development and implementation in the Solomon Islands.
- ❖ Fourthly, it will benefit the teacher educators responsible for training pre-service technology education teachers in the Solomon Islands.

From this study, a teacher professional development model could be recommended for enhancing teachers' concepts and classroom practices, not only for technology education but for other curricula as well. These points have substantiated the reasons for pursuing this

research study.

b Objective

1. To explore and identify 8 – 10 technology education teachers' current views of technology and technology education, as well as their classroom practice.
2. To explore the effect and influence of the professional development programme on teachers' concepts of technology and technology education.
3. To explore the extent to which the professional development has on influencing the teachers' classroom practice in teaching the new technology education curriculum.
4. To make recommendations for future professional development programmes in regard to enhancing teachers' concepts of technology and technology education and classroom practices in technology education in the Solomon Islands.

c Procedure for recruitment of participants and obtaining informed consent

Permission to undertake this research will be obtained from the research committee at the Ministry of Education and Human Resources and the Minister of Education in the Solomon Islands. This research study will involve 8-10 secondary school teachers. These teachers who will be participating in this research inquiry will be selected from the secondary schools in Honiara. These participants' informed consent will be obtained through their relevant authorities as well as themselves at the schools by letter.

d Procedures in which research participants will be involved

This research project will involve the 8-10 technology education teachers in two separate research phases. The initial phase of the research project will be conducted towards the end of 2005, and second phase in the latter part of 2006. In the first phase, participants will be involved in interviews and classroom observations. The interviews may take up 40 minutes, and will be undertaken at a pre-arranged time and place, and also out of class times to avoid class interference. The interviews will be recorded and transcribed and the transcripts will be returned to the teachers for verification. During the second phase of this research project these participants will be involved in short professional development workshops and classroom activities. The data collected from the professional development programmes will be undertaken through informal interviews, causal discussions and general observations. The events happening in the professional development programmes will be noted in the researcher's journal. Later, the participants will be observed in their classrooms while teaching the new technology curriculum and will also be interviewed. Teachers will be observed twice while implementing their planned activities. Obtaining students' consent for classroom interaction during classroom observation will not be necessary, as the teachers will inform their students about the observer through normal introduction procedures.

e Procedures for handling information and materials produced in the course of the research

All interviews will be recorded, transcribed and analysed. Transcriptions will be returned for verification. Observation notes will be recorded in the researchers' journal and will also be analysed as data. The teachers' work documents will be photocopied and analysed and also used as data. All information will be retained in a secure place for the duration of the research and will only be made available to the participant to whom it belongs if requested. The raw data belongs to the participant and the researcher has the ownership and the responsibility for the analysed data. At the end of the research, the data will be retained by the researcher in confidence and destroyed three years after the end of the project.

4 Ethical Concerns

a Access to participants

Initial access to get permission to conduct this research will be obtained through the Senior Research Officer for the Solomon Islands Research Committee based in Honiara at

the Ministry of Education and Human Resources Development. The Minister of Education and Human Resources Development will also be contacted to endorse this research study. The technology education teachers who will be participating in this study will be informed by letter, and will be accessed directly through the principal of their schools.

b Informed consent

Participants will be informed of their accessibility to the data they have provided, and will be kept informed about what is happening to the data they supply and what the analysis is showing where appropriate. Participants will also be informed of their on going right to withdraw from this research at any time. If they withdraw all data pertaining to them will be returned where possible, or destroyed. Throughout the research the willingness of the participants will be monitored, and the researcher will respond accordingly.

c Confidentiality

Participants' confidentiality will be respected and maintained at all times. This is very important as the population involved in this research project is small and the schools and communities involved are also small and closely tied. Participants' names and schools will not be published, but rather be coded in such a way to reduce risks of identification of individuals as much as possible. In this way every effort will be made to uphold the participants' anonymity, and to avoid any adverse impact on the participants. Data will only be accessed by the participants who supply it and the researcher and researcher's supervisors.

d Potential harm to participants

There is no significant harm that can be foreseen for the participants as the researcher also has the same ethnic and cultural background. Every situation will be monitored by the researcher in an effort to minimise any potential harm.

e Participants right to decline

Participants have, and will be informed of the right to decline from being involved in this research at any stage, to withdraw from it, or to stop the use of any of the research data they supply, or request the tape recorder to be turned off.

f Arrangements for participants to receive information

During the research the participants may ask for any portion of the data they have given. There will be consultation with the participants to verify the accuracy of transcribed data. Any material written up for publication or distribution will be made available to participants if requested.

g Use of information

The primary use of the data will be for the preparation of a PhD thesis. It is also likely that the data and subsequent analysis will be used as a basis for published papers, conferences and seminars, as well as resource materials for the Ministry of Education in the Solomon Islands.

h Conflicts of interest

The researcher is taking his role as a Solomon Islander and also the provider of the professional development programmes. This research study will be conducted through using the cultural norms and accepted practices within the local community. When undertaking the professional development, the researcher will be the professional development provider and other times the researcher will be a participant observer. A

firm professional relationship will be maintained between the researcher and the participants. The purpose of the participants' involvement in this research will be explained to them.

i Other ethical concerns relevant to the research

Open dialogue with all participants will be encouraged to discuss any aspects that might affect this research.

j Procedure for resolution of disputes

All participants will be informed about the procedures for resolving dispute within the research timeframe. The procedures are: to talk with the researcher to discuss and resolve the disagreements or disputes of concern in the first instance. If no resolution is reached at this stage then the second step is to contact my supervisors at the University of Waikato. In both cases, a clear explanation will be made to the participant(s) and other parties. My contact address and phone number at Honiara in the Solomon Islands, and my supervisors contact address at the University of Waikato will be clearly printed on a sheet of paper, and will be given to all participants.

5 Ethical Statement

The project will follow the University of Waikato Human Research Ethics Regulations 2000 and the ethical guidelines of the NZARE and include the following. Informed consent of participants will be obtained, without coercion. Exploitation (or perception of exploitation) of researcher-participant relationship will be prevented. Privacy and confidentiality will be respected. The participant will own the raw material collected, and their requests regarding the material will be honored. Participation in the research will not impact professionally on the participants.

6 Legal Issues

a Copyright

Copyright owned by the researcher

b Ownership of materials produced

The research data are owned by the participants and the analysis of the data is owned by the researcher

c Any other legal issues relevant to the research

None

7 Place in which the research will be conducted

Honiara, Solomon Islands.

8 Has this application in whole or part previously been declined approval by another ethics committee?

No

9 For research to be undertaken at other facilities under the control of another ethics committee, has an application also been made to that committee?

No other ethics committee is required, apart from obtaining a permission to undertake this research from the Ministry of Education and Human Resources and the Minister of Education in the Solomon Islands.

10 Further conditions

In the event of this application being approved, the undersigned agrees to inform the Human Research Ethics Committee of any change subsequently proposed.

5 Applicant Request for Approval of Ethics Application

Signed by the Applicant

Date

Signed by the Supervisor

Date

Signed by the Chairperson/Director

Date

The ethics application is approved/requires further work

Signed on behalf of the Committee

(Chairperson of the Committee

Date

Appendix C

The Initial Interview Questions

Personal Career History

1. What is your name?
2. What grades do you teach?
3. How long have you been teaching?
 - (a) Have you taught at other schools?
 - (b) How long have you taught at XX schools? (For each of the other schools)
5. What is your main role at your current school?
6. Have you had any other roles in other schools?

Teachers' views of Technology

1. What comes to mind when you think of the word technology?
2. What are some examples that you can think of as technology?
3. What comes to mind when you think of the word indigenous or traditional Solomon Islands' technology?
4. What do you perceive as the importance of technical and technology education?

Teachers' views of Technology Education

1. What comes to mind when you think of the word technology education?
2. Is there a need for technology education curriculum? What do you think about the new technology curriculum?
3. What do you get the students to do in technology education? What are some of the topics you have included?
4. What have you already taught in technology? How do you plan your lessons?
5. What are some of the activities you have used when planning your technology education lessons? What assessment methods do you use in your school?
6. How do you use the curriculum centre's materials to help you plan your teaching? What resources do you use?
7. Do you also teach other subjects apart from technology? What is the difference about teaching technology education from the other subjects?

Teachers' Views of professional Development of Technology Education

1. Do you think technology education teachers need some kind of workshops or in-service trainings or not, before they can be able to implement the technology curriculum in their schools. Why?
2. What specific technological areas would you recommend to be considered as priority areas for an immediate professional development in technology education?
3. What do you perceive as important for your own professional development in technology education?
4. Have you got any other comments that you would like to add?

Classroom Observations and Interview Questions

Interviews before a lesson begins

1. What do you aim to achieve from this lesson? What are your learning outcomes?
2. What resources are you going to use? What assessment methods will you use? What assessment are you going to do?
3. How do you know your students have learnt today from this unit?

Interviews during the lesson

1. Are you happy with the way the lesson is going?
2. Do you have any comments to add?

Interviews at the end of the lesson

1. How do you think the lesson went today? Are you satisfied with the way the lesson went today?
2. What do you perceive as an achievement from this lesson?
3. If you teach this lesson again would you like to make some changes or not? If yes, what changes and why?
4. What other comments would you like to add?

Students Interview Questions

1. What do you like about technology.
2. Can you tell me about this work you are doing? What have you learnt from this lesson?
3. Is there any thing that you are finding it difficult? How do you think you'll solve them? What do you think you will do next? How does you teacher help you learn?
4. Is there any thing that you find easy?

Classroom Observations

Observe three parts of the lessons

- The beginning part of the lessons
- The middle part of the lessons
- The ending or conclusion part of the lessons

Appendix E

Under Secretary,
Research Study Committee,
Ministry of Education and Human Resource Development,
P.O. Box G28,
Honiara,
Solomon Islands.

03 / 08 / 05.

Centre for Science and Technology
Education Research

The University of Waikato
Private Bag 3105
Hamilton, New Zealand

Ph: 64-7-838 4035 (Centre direct line)
Fax: 64-7-838 4272



The
University
of Waikato
Te Whare Wānanga
o Waikato

Dear Sir / Madam,

Re: Seeking an approval to conduct a research on secondary school teachers.

In regard to the reference stated above.

I am a Solomon Islander and currently enrolled as a postgraduate student at the University of Waikato, Hamilton, New Zealand. I am studying for a degree of Doctorate of Philosophy and my field of study is in technology education.

The title of the study is: **Professional Development in Technology Education in the Solomon Islands: enhancing teachers' concepts of technology and technology education to enhance classroom practice.** In this research project, I would like to involve at least 10 secondary school teachers in schools in Honiara. These teachers will be involved in professional development programmes, which will enhance their classroom practice when implementing the new technology curriculum. I would also like to involve them in short interviews (approximately about 15 - 20 mins) and classroom observations for my data collection.

The research study will be done in two phases and the researcher will track this study over a period of 9 months. The two phase of the research inquiry are interrelated and interdependent in nature. The findings of the preliminary inquiry in phase 1 will be used as the basis for developing and delivering of the professional development programme for the technology education teachers in phase 2. The Timeline for the home-located research is outlined in the diagram below.

Phase 1 – Preliminary Inquiry - 3 months period (From September - November 2005)

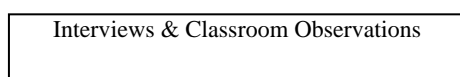

Phase 2 – Professional Development and Classroom Practice - 6 months periods (From June - November 2006)



I'll be coming on the 6th of September, and would expect to begin conducting this research study in mid-September through to mid-November 2005, on technology education teachers in Honiara. With this regard, I would like to obtain an approval to carry out this research study in the secondary schools in Honiara. Further details will be discussed when I arrive in Honiara.

Also enclosed is a copy of my research proposal, and your cooperation is very much appreciated.

Yours Sincerely

David Sade.

cc Minister of the Ministry of Education and Human Resource Development
cc Permanent Secretary of the Ministry of Education and Human Resource Development

Appendix F



The
University
of Waikato
*Te Whare Wānanga
o Waikato*

The University of Waikato

Centre for Science & Technology Education Research

The Information for Prospective Participants

- This research study consists of an investigation into the effectiveness of the professional development in technology education in the Solomon Islands.
- This study is undertaken in two phases. In the preliminary phase, this study seeks to understand the current views and ideas held by the secondary school technology education teachers on technology and technology education, and also their current teaching practice that might influence their teaching of the new technology education curriculum in the Solomon Islands. In the final phase, this study seeks to understand the effectiveness of the teacher professional development and its effect on influencing of the teachers' concepts and classroom practice in teaching of the new technology curriculum in the Solomon Islands.
- In the preliminary phase, teacher participants will be involved in short interviews and will also be observed during their regular teaching sessions. In the second phase, teachers will be participating in the teacher professional development, and also doing classroom-teaching sessions. Teacher participants will also be interviewed and observed during their normal teaching sessions.
- This study is aimed at enhancing technology education teachers' concepts of technology and technology education to enhance their teaching of the new technology education curriculum in the Solomon Islands.

Researcher Contact Details

David Sade
Centre for Science & Technology Education Research
The University of Waikato
Private Bag 3105
Hamilton, New Zealand
Ph: (64) 7 838 4466 ext- 8926
Email: ds12@waikato.ac.nz



The University of Waikato

Centre for Science & Technology Education Research

The Participant Consent Form

I understand that participation in this research project will involve the following:

- I will be involved in a study on *professional development in technology education in the Solomon Islands*.
- This study will be conducted under the research guidelines of the University of Waikato's Ethics Committee. Data gathered for this project will be used only for the purpose of writing the thesis, conference presentations, published papers and talks, and will not be made available to any third party or for any purposes other than what is being specified.
- My anonymity will be considered, and that I will not be identified in any way other than a code number in data records or reports of the research findings. All information that I provided will be securely kept as confidential, and be destroyed after three years.
- My participation in this study is voluntarily, and I may withdraw completely from this research project at any time. If I have any concerns about my participation in this research project, or the way in which the research project has impacted upon me, I may approach the Director of the Centre for Science & Technology Education Research (Ph: 64 7-838 4245), or the Minister of Education and Human Resources Development of Solomon Islands (Ph: 24 480) or the School Principal.

I have read and understand the above information regarding the research guidelines and agree to participate in this research.

Name _____

School _____

Signed _____

Date _____

Centre for Science and Technology
Education Research

The University of Waikato
Private Bag 3105
Hamilton, New Zealand

Ph: 64-7-838 4035 (Centre direct line)
Fax: 64-7-838 4272



The
University
of Waikato
Te Whare Wānanga
o Waikato

Dear Sir / Madam,

Re: Requesting Secondary School Technology Education teachers to Participate in this Research.

In regard to the reference stated above, I would like to invite you to participate in this research project.

The title of the study is: *Professional Development in Technology Education in the Solomon Islands: Enhancing Teachers' Concepts on Technology and Technology Education to enhance classroom practice.* The research study will be done in two phases and will be done over a period of 9 months. The two phase of the research inquiry are interrelated and interdependent in nature. The findings of the preliminary inquiry in phase 1 will be used as the basis for developing and delivering of the professional development programme for the technology education teachers in phase 2. The Timeline for this research inquiry is outlined in the diagram below.

Phase 1 – Preliminary Inquiry - 3 months period (From September - November 2005)

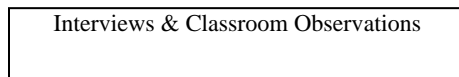

Phase 2 – Professional Development and Classroom Practice - 6 months periods (From June - November 2006)



Details of participants' involvement have been outlined in the information sheet for the prospective participants.

Your willingness and cooperation to participate in this research project is very much appreciated. However you may feel free to withdraw at any time, whenever you wish to do so.

Yours Sincerely

David Sade.

Researcher Contact Details

Centre for Science & Technology Education Research
The University of Waikato
Private Bag 3105
Hamilton, New Zealand
Ph: (64) 7 838 4466 ext- 8926
Email: ds12@waikato.ac.nz

Appendix G Teachers' Backgrounds

| <i>Teachers Name</i> | <i>Forms Taught</i> | <i>Years of Teaching</i> | <i>Teaching Experiences</i> | <i>Main Role</i> | <i>Other Roles</i> |
|----------------------|---------------------|--------------------------|------------------------------------|-----------------------|--|
| Gilson | 4 & 5 | 5 yrs | 1 st school Mechanic | Head of Dept | Maintenance supervisor |
| Ronald | 3, 4, & 5 | 6 yrs | 1 st school | Head of Dept | Sport master & Assistant work master |
| Anthony | 4 & 5 | 24 yrs | 3 rd schools | Head of Dept | School Maintenance |
| Jason | 1,2, & 3 | 17 yrs | 7 schools | School Principle | Head of Dept |
| Zebedee | 1 & 2 | 1 yrs | 1 st school | Assistance teacher | F1 Class teacher |
| Richard | 1,2&3 | 3 yrs | 1 st schools | Assistance teacher | School maintenance |
| Raymond | 4 & 5 | 20 yrs | 2 schools | Head of Dept | School Maintenance |
| Timmy | 1 & 2 | 3 yrs | 2 schools | Assistance teacher | |
| | | | | | |
| | | | | | |
| | | | | | |
| | | | | | |

Appendix H

44

SCREWS AND SCREWING

1:8:6

Description

Screws are fasteners or pieces of metal used for joining things together usually wood. They hold better than nails because of the threads they have. They are made from mild steel, brass, aluminium and stainless steel. Screwing is a process of driving the screw into the wood with a screw driver. The thread is the twisted or spiral part of the screw.

PARTS

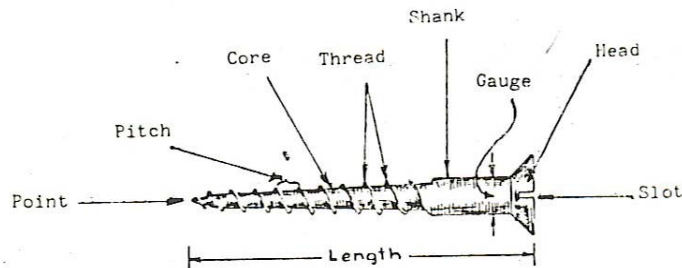

Types and Uses

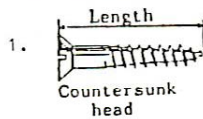

Countersunk head screws are used for fastening woods, metal to wood and hinges on doors. The top is straight, so the screw does not stick up.

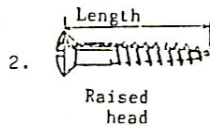

Raised head screws are used for fastening metal fittings, metal sheeting to wood and wood panelling which from time to time has to be removed.

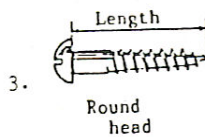

Round head screws are used for fastening metal to wood. e.g. metal brackets, louvre frames.

Below are some important points to remember when using screws and screwdrivers.

1. A screw must never be knocked in with a hammer.

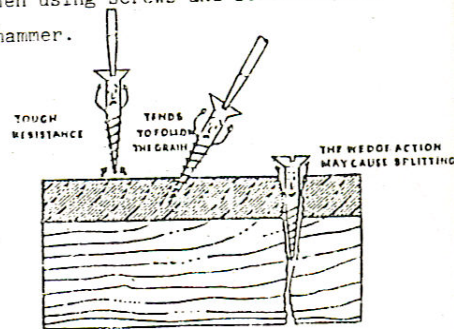

2. Always use the screwdriver that suits or fits the slot of the screw.

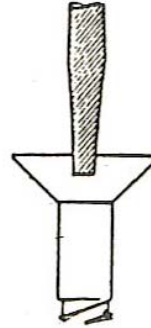
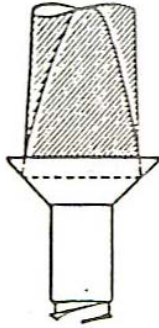

3. Always keep the blade of the screwdriver in good condition.

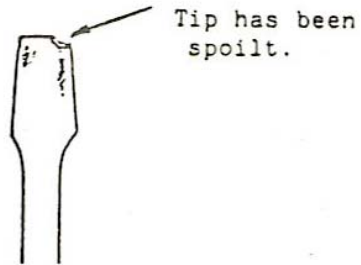
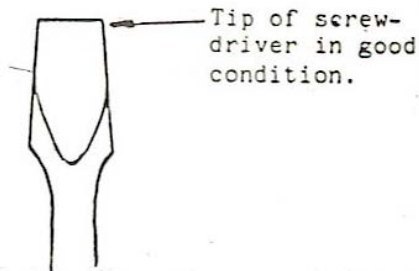

Homework Assignment

1. Why do screws have better holding power than nail?
2. Why is it important to use the screwdriver that fits well in the slot of the screw?
3. Which screw would you use for the following job? Give a reason for your choice.
 - (a) Fastening louvre frames.
 - (b) Fastening Butt hinges on a door.
4. Name two parts of the screw.

Glossary

Fasteners - devices used to secure two or more materials.

Wood Panelling - a thin surface of timber which covers the frame of a door, window or wall.

Screw threads - the twisted spiral parts which cut and pull the screw when screwing or un-screwing.

Appendix I

QUESTION 1 GUIDE. Orthographic Drawing

THIS QUESTION IS COMPULSORY.

Answer the question in the sheet of "A3 or A4" paper provided.

You should spend 1 hour and 20 minutes on this question.

Any measurement that is not included is left to you to work out.

Your completed drawing should include a full size development drawing, 10mm margin and the normal technical drawing information columns.

All measurements is in millimetre.

Question 1.

- i. Make a full-size third angle orthographic projection (drawing) of the safety bracket drawn below.
- ii. Add six (6) major dimensions to your drawing.

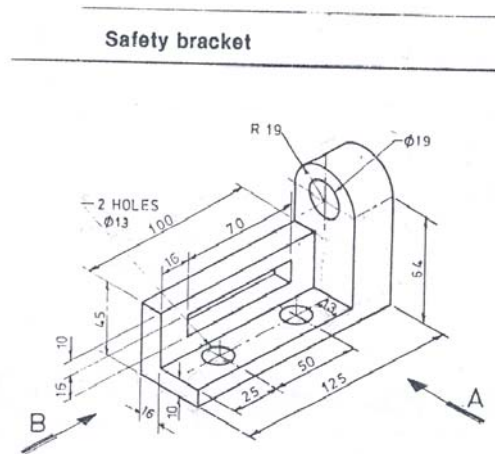

Draw the following views in 3rd angle projection:

- (a) a front view from A
- (b) a side view from B
- (c) a top view

(scale 1:1)

Appendix J

37

1:7:5

CLAW HAMMER

You will all have used a hammer for hitting things such as nails. A claw hammer is one of many kinds of hammers. It comes under percussion and impelling tools.

Parts

1. Head - This is made of cast steel.
2. Wedge - This is a piece of steel or wood that is driven into the top of the handle near the head to fix the head on tight.
3. Handle - Made of wood (ash, hickory) or steel.

Size

The size is determined by the weight of the head and varies between 350gm. - 750gm.

Uses

Claw hammers have two uses:

1. The flat head is used for driving or banging nails into wood.
2. The claw is used for pulling out or drawing nails.

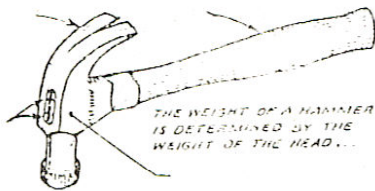

HOW TO DRAW A NAIL

STEP 1.

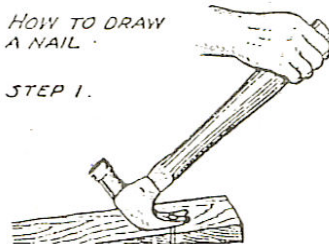

STEP 2.

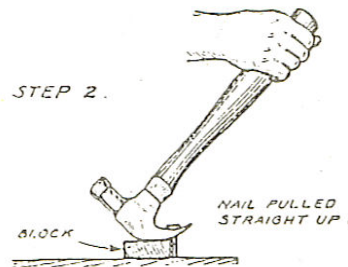

How to hit a nail

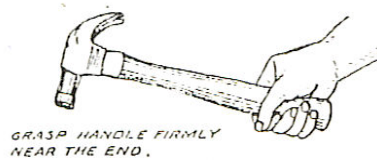

Put a wooden block under the hammer so that you don't damage the wood or bend the nail.

Homework Assignment

1. Draw a hammer as above and name the four parts shown with arrows.
2. What is the claw of the hammer used for?
3. How is the size of a hammer determined?

Glossary

Impel - drive; force.

Percussion - striking of one body against the other.

Appendix K

Raymond's Photocopied Notes

MATERIALS – PROPERTIES OF METALS.

There are (3) main types of metal:

- 1: Ferrous metals – contain mainly iron.
- 2: Non Ferrous metals – rarely contain any iron.
- 3: Alloys – are mixtures of different metals.

General Properties of Metals

Metals may be described under the following headings:

- **COLOUR** - is important as a quick way of grouping many metals.
- **TENACITY** - the ability of a metal to resist stretching without breaking.
- **MALLEABILITY** - the ability of a metal to be hammered, bent or rolled without fracture.
- **DUCTILITY** - the ability of a metal to be drawn out lengthwise (by stretching) without fracture eg. Wire drawing.
- **HARDNESS** - the ability of a metal to resist scratching or abrasion.
- **CONDUCTIVITY** - the ability of a metal to conduct electricity and heat.
- **BRITTLINESS** - Brittle metals will fracture or crack after little or no deformation. Brittleness is the opposite of toughness.
- **ELASTICITY** - the ability of a metal to return to its original size or shape.
- **FUSIBILITY** - the ability of a metal to be liquefied by the application of heat.

FERROUS METALS:

Ferrous metals combine iron and carbon in varying amounts and all of them are likely to rust when exposed to the weather.

| Metal | Composition | Identification/colour | Characteristics/Properties | Uses |
|---------------------------|--------------------------|-----------------------|---|-------------------------------|
| Mild Steel | Alloy of Iron and carbon | Grey in colour | Tough and ductile relatively inexpensive | Nuts, bolts and tubes |
| Tool steel (carbon steel) | High carbon | Smooth black | Tenacious, ductile, malleable. Prone to rust. | Wood, metal and plastic tools |
| Cast iron | Alloy of iron and carbon | Grey colour | Good wearing and machining qualities | Heavy crushing machinery |

NON - FERROUS METAL ALLOYS

This a group of metal alloys which do not contain carbon or Iron.

| Metal | Composition | Identification/colour | Characteristics/Properties | Uses |
|--------|-----------------------------------|-----------------------|--|---|
| Brass | Alloy of copper and zinc | Bright yellow | 1: Hardens quicker than copper when worked upon | 1: mainly for musical instruments, screws door hinges, etc. |
| Bronze | Alloy of copper and tin | Blackish brown | 1: stronger than Brass. 2: Easily cut and beaten. | 1: For bushings and bearings 2: Statues and models |
| Pewter | Alloy of Tin, Antimony and copper | Silvery white | 1: High resistance, to chemical reaction 2: Extremely soft 3: Very low melting point | 1: For making tableware, e.g Tea pot. |

Appendix L School Backgrounds

| School - B | | Boys | Girls | |
|----------------------------|-----|----------------|-------|----------------|
| No. students in school | 800 | 500 | 300 | |
| No. Teachers | 39 | | | |
| No. students in Tech class | 26 | | | |
| Forms - | 1-7 | Forms 1-4 | | 2 streams |
| | | Form 5 | | 3 streams |
| | | Form 6 | | 4 streams |
| | | Form 7 Sc/Arts | | 2 streams each |

| School - C | | Boys | Girls | |
|----------------------------|-----------|-------------|-------|-----------|
| No. students in school | 660 | 330 | 330 | |
| No. Teachers | 39 | | | |
| No. students in Tech class | 4-21/5-18 | 20/16 | 1/2 | |
| Forms - | 1-7 | Forms 1-6 | | 2 streams |
| | | Form 7 Arts | | 1stream |
| Primary 2 streams –Std 1-6 | | | | |

| School - E | | Boys | Girls | |
|----------------------------|-----|-----------|-------|-----------|
| No. students in school | 400 | 200 | 200 | |
| No. Teachers | 22 | | | |
| No. students in Tech class | 7 | | | |
| Forms - | 1-7 | Forms 1-5 | | 2 streams |
| Primary 2 streams –Std 1-6 | | | | |

| School - D | | Boys | Girls | |
|------------------------------------|-----|-------------|-------|-----------|
| No. students in school | 837 | 440 | 397 | |
| No. Teachers | 35 | | | |
| Average No. of students in a class | 60 | | | |
| Forms - | 4-7 | Forms 4-6 | | 4 streams |
| | | Form 7 Arts | | 1 stream |

| School - A | | Boys | Girls | |
|------------------------------------|---------------|----------------|-------|---------------|
| No. students in school | 480 | 224 | 226 | |
| No. Teachers | 29 | | | |
| Average No. of students in a class | 36 sdts/class | | | |
| Forms - | 1-7 | Forms 1- | | 2 streams |
| | | Form 5 | | 3 streams |
| | | Form 6 Sc/Arts | | 1 stream each |
| | | Form 7 Sc/Arts | | 1 stream each |

| School – F | | Boys | Girls | |
|------------------------------------|---------------|-------------|--------------|-----------|
| No. students in school | 657 | 332 | 325 | |
| No. Teachers | 26 | | | |
| Average No. of students in a class | 40 sdts/class | | | |
| Forms - | 1-6 | Forms 1- 6 | | 2 streams |
| | | | | |
| | | | | |
| | | | | |

Appendix M
Technology Education Questionnaire Sheet – Overall Evaluation on
Teachers’ Workshop - 2006

1. After the two workshops and the two classroom practice sessions, have your views on technology and technology education changed? Yes / No

If yes, what is your current views now on:

a) Technology;

b) Technology Education;

2. Do you think what you have taught during this trial period is technology education?
Yes / No

If yes why do you think it is technology?

3. What have you learnt from the two workshops that you found easy or difficult to implement during the two classroom practice sessions?

a) Easy to Implement;

b) Difficult to implement

4. Has the workshop on assessment changed your views on assessing students in technology education? Yes / No

If yes what is your current views?

5. In brief;

- a) What do you expect your students to learn from the classroom task you teach?

- b) How do you know that your learning outcomes have been achieved?

6. Has the workshop and the classroom practice experience session helped you in

- a) Becoming an effective technology education teacher?

- b) Teaching your students to become effective learners?

Thank you for taking the time to fill in this sheet, the information is invaluable in the planning of ongoing professional development

Appendix N

Definitions of Technology

- Technology is derived from the Greek words *tekhne*, which means art or skill, (*tehton*, - Builder) and *logia*, which means science (*knowledge*) or study. “Technology is a praxiological knowledge,” it is a practice of knowledge, which involves the practising of an art or skill (Lux, 1983).
- Technology is the “application of knowledge, tools, and skills to solve practical problems” (Johnson, 1989)
- Technology is the work of engineers, inventors and technologists. They apply knowledge, sometimes from scientific theories or other sources of knowledge and sometimes from experience, to create and commercialise devices and systems to meet human goals (Naughton, 1992).
- Technology is a social process in which abstract economic, cultural, and social values, shape, develop and implement specific artefacts and techniques that emerge from the distinct technical problem-solving activity called engineering which is embedded in that process (Cutcliff, 1981)
- Technology is the way humans expand their possibilities by using intellectual and practical resources to intervene in the world through the development of artefacts, systems and environments. Technology is influenced by and impacts on cultural, ethical, environmental, political and economic factors in both local and global contexts. (Ministry of Education [MoE], 2005).
- Technology is concerned with the design, making and improvement of artifacts and systems to meet human needs, through the use of knowledge, physical resources and skills (Fensham, P.J., and Gardener, P.L, 1994)
- Technology is not only technical in nature, but also influenced by culture and the role of people and organisations in societies, and vice-versa. (Pacey’s 1993).
- Technology is the process by which society identifies human problems and seeks to solve them. It includes design and preparation of a solution, which may be an artifact, process, system, or environment, and the evaluation of the solution from the perspective of all those involved. (Burns, J., 1992)
- ... the know-how and creative process that may utilize tools, resources and systems to solve problems, to enhance control over the natural and man-made environment in an endeavor to improve the human condition. (UNESCO, 1986)

Appendix O

Rest of the teachers' technology lesson planning

The example lesson plan format was also used by Gilson. Hence his lesson plan was also organised under task definition, generic learning outcomes as overall dimension of technology and specific learning outcomes outlined under conceptual, procedural, technical, and societal (see Figure 7.5: Gilson's lesson plan). Gilson's lesson plan was intended for his Form Five technology class.

Figure 7.5:
Gilson's lesson plan

| Planning for Learning in Technology Education | | | |
|---|--|---|---|
| Task Definition Design and construct a range of electronic products which has different uses. | | | |
| Overall Dimension of Technology Conceptual – understand the specific use of the electronic products which they are constructing. Procedural – Follow the procedures for connecting the electronic circuits Technical – Demonstrate technical skills in screwing and circuit connection Societal – Identify the range of preferences people have for different electronic products. | | | |
| Conceptual Learning Outcomes | Procedural Learning Outcomes | Technical Learning Outcomes | Societal Learning Outcomes |
| Understand that: - Different electronic components have different functions. - an electronic circuit must be connected properly in order for the circuit to work | Understand the procedures for: - Connecting the electronic components in a circuit - Following the circuit diagram - Testing the circuit to see if it works - Tracking any problems if the circuit does not work | Be able to: - Use hand drill to drill holes on the circuits for the screws to hold the wires firmly together - Skilfully fastened the wires that connect the circuits with screws to hold the circuit in positions. | Understand that different people have different preferences for different electronic products |

Gilson's task definition was to design and construct a range of electronic products. This task was based on a range of electronic activities taken from the MoE prescribed textbooks with no specific context. Gilson's lesson was his preplanned lesson for semester two of 2006, which mainly focused on meeting examination requirements. However, with the use of the lesson plan formats he was able to outline his lessons using the outcome-based approach. His generic learning outcomes under the conceptual dimension were focused on the purposes of electronic products, and under the procedural dimension the focus was on working procedures. The generic learning outcomes under the technical dimension were based on hand skills and the societal dimension was based on people's preferences.

Gilson’s specific learning outcomes were derived from his generic learning outcomes as stated under overall dimensions of technology. Gilson had two specific learning outcomes under conceptual, and these were focused on the functions of the electronic components in a circuit, and the craftsmanship of the person connecting the circuits. The four specific learning outcomes under procedural were focused on circuit connection procedures, the required procedures for construction process, the procedures for testing circuits, and trouble shooting procedures. The two specific learning outcomes under technical were mainly focused on drilling skills, and screwing skills, while the societal learning outcome focused on the understanding of people preferences for different electronic products.

Figure 7.6 shows Gilson’s programme of work which consisted of his time schedule for class task and his lesson sequence in undertaking the technology task in semester two of 2006. His programme of work was similar with the other teacher participants as the same format was used by all teacher participants. Gilson’s work was also organised into weeks under the three phases of the design process with classroom activities intended to be undertaken by students.

Figure 7.6:
Gilson’s programme of work

Semester two Unit Planner - 2006

| Weeks | Design Process Phases | Activities |
|---------|--|--|
| Week 1 | Investigation, Designing and Devising ↓ | Identify context – Real life situation, News papers, Community based information etc |
| | | Brain storm – to identify & select the technological task |
| Week 2 | | Develop design brief or task definition |
| | | Identify the appropriate strands (learning areas) related to the task defined |
| | | Consider the stake holders involved and include them in the investigation process |
| | | List specifications required for constructing the task |
| Week 3 | | Devising initial ideas |
| | | Designing the initial concepts – 2D/3D – Drawing skills |
| Week 4 | | Technical drawing skills – Orthographic & Pictorial - Isometric/oblique |
| | | More investigation and research – Technological & societal knowledge/concepts |
| | | <ul style="list-style-type: none"> • Interviews/surveys – develop questionnaires • Recorded/researched notes - Communication skills |
| Week 5 | | Identify relevant technological / scientific concepts related to the product |
| | | <ul style="list-style-type: none"> • Note taking – uses of the product, required design & scientific principles • Research and note taking - |
| Week 6 | | Reassess/evaluate the designing and devising process |
| | | <ul style="list-style-type: none"> • Self/peer analysis • Teacher/client analysis |
| Week 7 | Construction Phase ↓ | Students construct their designed products |
| | | Knowledge/skills to be taught/learnt |
| Week 8 | | Drilling lesson - Learn to use the electric drill to drill holes on the circuit board |
| | | Knowledge/skills to be taught/learnt |
| | | Striping lesson - Striping wires with the pliers to allow contact with the screws |
| Week 9 | | Knowledge/skills to be taught/learnt |
| | | - fastened the wires around the screws and tightening the screws with the screw drivers |
| Week 10 | | Knowledge/skills to be taught/learnt |
| | | Testing the circuits and locating problems |
| Week 11 | Evaluation and marketing promotion ↓ | Evaluation of the project |
| | | Students’ final assessment of their task as they reflected on their finish task |
| Week 12 | | Final presentation |
| Week 13 | | Promotion and Marketing |
| Week 14 | | |

Gilson planned to cover his full programme of work for his Form Five technology class in 13 weeks. He planned to cover the designing phase in six weeks, and also decided to use the activities as given in the example programme of work (see Figure 6.3). The activities included identifying the context, developing design brief and specifications, developing initial ideas using 2D and 3D technical drawings, investigating and researching more ideas, taking related notes, reassessing and evaluating the initial design idea or concepts. He planned to cover the construction phase in four weeks and planned to teach the skills related to the construction of the electronic projects. The skills included drilling, stripping of wire coating, fastening using screwdrivers, and testing to identify problems. He also decided to use the same activities as outlined under evaluation and marketing promotion in the example lesson plan given to teachers during the PD programme.

This lesson plan in Figure 7.7 is Raymond’s defined task and learning outcomes. Raymond’s learning outcomes were also generic and specific as stated under the overall dimension of technology and under these four learning domains; conceptual, procedural, technical and societal. Raymond’s lesson plan was intended for the Form Five technology class which he taught in the second semester of 2006.

Figure 7.7:
Raymond’s lesson plan

| Planning for Learning in Technology Education | | | |
|--|--|--|---|
| Task Definition Design and make a coconut scraper on stool for convenient use. | | | |
| Overall Dimension of Technology Conceptual – Explore the key principles required for designing a coconut scraper on a stool Procedural – Undertake the procedures required under the design process approach Technical – Develop skills for constructing the coconut scraper. Societal – Identify people’s preferences for having a coconut scraper on a stool. | | | |
| Conceptual Learning Outcomes | Procedural Learning Outcomes | Technical Learning Outcomes | Societal Learning Outcomes |
| Understand that: - The coconut scraper should be tightly fixed to the stool. - Strength and balance are the most important parts of the stool - The coconut scraper must be sharp and easy to be maintained, and also easy to use and be easily stored away | Understand the procedures for: - Drawing isometric and orthographic views. - Doing researches and investigations on types of coconut scrapers - Constructing the coconut scraper - Using the require tools – hand saw, plan, electric drill, grinding machine, hacksaw - Evaluating some aspects of the coconut scraper - Communicating and market this particular coconut scraper | Be able to: - Do technical drawing – isometric and orthographic views - Do technical skills such as: measure, mark-out, cut, planning, drilling, grinding, cutting, sanding, and painting. | Understand people’s preferences for the coconut scraper on a stool. |

As shown in Figure 7.7 Raymond's defined task was to design and make a coconut scraper on a stool for its convenient use. Raymond's defined task had no specific context as his focus was based on examination requirements. This task was his preplanned task for semester two of 2006; however, with the use of the lesson plan format he was able to plan his lesson using the learning outcome based approach. His generic learning outcome under conceptual was based on key principles for designing coconut scrapers on stools, and his procedural dimension was based on the design process. Under the technical dimension, the focus of his generic learning outcome was on developing construction skills, and the societal dimension was focused on people's preferences for coconut scrapers on stools.

Raymond's specific learning outcomes were also derived from his generic learning outcomes stated as overall dimensions of technology. He had three specific learning outcomes under conceptual, and these are stated as understanding the proper fittings required for attaching the metal scraper on to the wooden stool, the importance of strength and balance in designing the stool structure, and the significance of serving its purpose. The six learning outcomes under procedural were focused on technical drawing procedures, research and investigation procedures, construction procedures, the required procedures for using technical tools and machines, the evaluation and marketing procedures of the product. The two learning outcomes under technical were focused on the skills required for making technical drawings and for using hand and power tools, and the learning outcome under societal was focused on understanding people's preferences.

Raymond's programme of work as shown in Figure 7.8 was also organised into weeks, the three phases of the design process approach, and the activities to be undertaken by students as they worked through their technology task. This programme provided the Raymond with the time frame to which he needed to keep in order for the students to get the task done on time.

Figure 7.8:
Raymond's programme of work

Semester two Unit Planner - 2006

| Weeks | Design Process Phases | Activities |
|---------|--|--|
| Week 1 | Investigation, Designing and Devising ↓ | Identify context – Real life situation, News papers, Community based information etc |
| | | Brain storm – to identify & select the technological task |
| Week 2 | | Develop design brief or task definition |
| | | Identify the appropriate strands (learning areas) related to the task defined |
| | | Consider the stake holders involved and include them in the investigation process |
| | | List specifications required for constructing the task |
| Week 3 | | Devising initial ideas |
| | | Designing the initial concepts – 2D/3D – Drawing skills |
| Week 4 | | Technical drawing skills – Orthographic & Pictorial - Isometric/oblique |
| | | More investigation and research – Technological & societal knowledge/concepts |
| | | <ul style="list-style-type: none"> • Interviews/surveys – develop questionnaires • Recorded/researched notes - Communication skills |
| Week 5 | | Identify relevant technological / scientific concepts related to the product |
| | | <ul style="list-style-type: none"> • Note taking – uses of the product, required design & scientific principles • Research and note taking - |
| Week 6 | | Reassess/evaluate the designing and devising process |
| | | <ul style="list-style-type: none"> • Self/peer analysis • Teacher/client analysis |
| Week 7 | Construction Phase ↓ | Students construct their designed products |
| | | Knowledge/skills to be taught/learnt |
| Week 8 | | - Cutting of the timbers into required lengths |
| | | Knowledge/skills to be taught/learnt |
| | | - Cutting and chiseling the joints for the wooden frames |
| Week 9 | | Knowledge/skills to be taught/learnt |
| | | Gluing and nailing the wooden frames together |
| Week 10 | | Knowledge/skills to be taught/learnt |
| | | Cutting and shaping of the metal to be used for crushing the coconut flesh from inside the shells |
| Week 11 | ↓ | Knowledge/skills to be taught/learnt |
| | | - Fixing the metal scraper on to the wooden frame |
| Week 12 | | Knowledge/skills to be taught/learnt |
| | | Sanding |
| Week 13 | | Knowledge/skills to be taught/learnt |
| | | Varnishing / painting of the coconut scraper frame |
| Week 14 | Evaluation and marketing promotion ↓ | Evaluation of the project |
| | | Students' final assessment of their task as they reflected on their finish task |
| Week 15 | | Final presentation |
| Week 16 | | Promotion and Marketing |

As shown in Figure 7.8, Raymond planned to cover his programme of work in 16 weeks of the second semester of 2006. He planned to cover the designing phase of the design process (investigation, designing and devising) in six weeks, and also decided to use the activities as given in the example programme of work (see Figure 6.3). The activities were identifying the context, developing design brief and specifications, developing initial ideas using 2D and 3D technical drawings, investigating and researching more ideas, taking related notes, reassessing and evaluating the initial design idea or concepts. He planned to cover the construction phase in seven weeks, and planned to teach the following skills: woodworking skills of cutting, chiseling, gluing, and nailing; metalworking skills of cutting, filing and shaping, and fastening; and the finishing skills of sanding, varnishing and painting. He planned to cover the evaluation phase in three weeks using the activities given in the example lesson format under evaluation and marketing promotion (see Figure 6.3).

Richard's lesson plan was intended for teaching his Form Two technology class in 2006. His lesson plan as shown in Figure 7.9 consists of a defined task, generic learning outcomes stated as overall dimensions of technology and specific learning outcomes outlined under conceptual, procedural, technical and societal aspects.

Figure 7.9:
Richard's lesson plan

| Planning for Learning in Technology Education | | | |
|--|---|---|--|
| Task Definition Design and make a safety box to keep personal items securely and safe | | | |
| Key Learning Areas (Strands) | | | |
| Integrated Dimension of Technology Conceptual – Explore the key principles/areas of designing a box Procedural – Design and construct box to meet requirements Technical – Develop specific skills to construct box Societal – Identify the preferences people have on the product | | | |
| Conceptual Learning Outcomes | Procedural Learning Outcomes | Technical Learning Outcomes | Societal Learning Outcomes |
| Understand - that strength and balance is an important aspect of the box - that safety and security is the most important aspect of this box - the property of materials determines its suitability for the task | Understand the procedures for: - Keeping students' journal / design folio - Research / Investigation - Designing the box - Making the box - Using hand saw and plan - Assembling the parts of the box together - fixing hinges, and hasps and staples - Applying finishing to the box - Evaluating the box - Communicating and marketing of the box | Be able to: - Do technical drawing skills such as: pictorial and working drawing – Isometric and orthographic - Do technical skills as: - measure, and mark out - cutting, - planning - chiselling - screwing - paint / varnish | Understand that different people have different preferences for the use of the box |

Richard's defined task was to design and construct a safety box to keep personal items safe and secure. He chose this project for his technology class for semester two after some students complained to him about their money and little items like jewelry were stolen in their dormitories. By using this lesson format he was able to outline his generic and specific learning outcomes. His generic learning outcomes stated as overall dimension of technology under conceptual were focused on key principles of designing wooden boxes, and his procedural dimension was focused on designing and construction. His technical dimension was based on construction skills and considering people's preferences for the uses of boxes as his societal dimension.

Richard's specific learning outcomes were derived from his generic learning outcomes stated as overall dimensions of technology. Richard had three specific learning outcomes under conceptual, and were focused on first, the understanding of the principles of strength and balance; second, the concept of security; and third, the significance of material selection. Then he had 10 learning outcomes under procedural which focused on the procedures for keeping a student journal, research, investigation and design, the making procedures including the use of hand tools, assembling, hinge attachment and finishing. He then wound up with the evaluation and marketing procedures. There were two main learning outcomes under technical which focused on technical drawing skills and skills in using hand tools, and finally the societal learning outcome which focused on people's preferences for the use of the boxes.

Richard also used the unit planner format to plan his programme of work for his Form Two technology class. Just as the other teachers had organised their programme of work into weeks and so has Richard as shown in Figure 7.10.

Figure 7.10:
Richard's programme of work

| Weeks | Design Process Phases | Activities | | |
|---------|--|---|---|---|
| Week 1 | Investigation, Designing and Devising ↓ | Identify context – Real life situation, News papers, Community based information etc | | |
| | | Brain storm – to identify & select the technological task | | |
| Week 2 | | Develop design brief or task definition | | |
| | | Identify the appropriate strands (learning areas) related to the task defined | | |
| | | Consider the stake holders involved and include them in the investigation process | | |
| Week 3 | | List specifications required for constructing the task | | |
| | Devising initial ideas | | | |
| | Designing the initial concepts – 2D/3D – Drawing skills | | | |
| Week 4 | ↓ | Technical drawing skills – Orthographic & Pictorial - Isometric/oblique | | |
| | | More investigation and research – Technological & societal knowledge/concepts | | |
| | | • Interviews/surveys – develop questionnaires | | |
| | | • Recorded/researched notes - Communication skills | | |
| Week 5 | | Identify relevant technological / scientific concepts related to the product | | |
| | | • Note taking – uses of the product, required design & scientific principles | | |
| | • Research and note taking - | | | |
| Week 6 | ↓ | Reassess/evaluate the designing and devising process | | |
| | | • Self/peer analysis | | |
| | | • Teacher/client analysis | | |
| Week 7 | | Construction Phase ↓ | Students construct their designed products | |
| | | | Knowledge/skills to be taught/learnt | |
| Week 8 | | | - Measuring and cutting of the plywood into require lengths | |
| | Knowledge/skills to be taught/learnt | | | |
| | - Marking out and cutting of Mitre joints for the corners of the box – cutting with hand saw | | | |
| Week 9 | -Tidy the Mitre joints with the hand plane – use hand plane | | | |
| | Knowledge/skills to be taught/learnt | | | |
| | Assembling the side of the box together – gluing and nailing skills | | | |
| Week 10 | ↓ | Assembling the top and bottom on to the side of the box - gluing and nailing skills | | |
| | | Knowledge/skills to be taught/learnt | | |
| | | Cut through the side of the box into two halves. The smaller half is to be used as the lid for the box – use hand saw | | |
| Week 11 | | ↓ | Knowledge/skills to be taught/learnt | |
| | | | Fixed the hinges and the hasps and staples | |
| Week 12 | | | ↓ | Knowledge/skills to be taught/learnt |
| | Sanding and varnishing of the wooden box | | | |
| Week 13 | Evaluation and marketing promotion ↓ | | | Evaluation of the project |
| | | | | Students' final assessment of their task as they reflected on their finish task |
| Week 14 | | ↓ | | Final presentation |
| | | | | |
| Week 15 | | | ↓ | Promotion and Marketing |
| | | | | |
| | | | | |
| | | | | |
| | | | | |
| | | | | |

Richard planned to cover his programme of work in 15 weeks. His programme of work for the first phase of the design process (investigation, design and devising) was six weeks, and he also decided to use the activities given in the example programme of work (see Figure 6.3). The activities included identifying the context, developing design brief and specifications, developing initial ideas using 2D and 3D technical drawings, investigating and researching more ideas, taking related notes, reassessing and evaluating the initial design idea or concepts. The construction was planned to be covered in another six week and planned to teach the following skills: wood working skills of measuring and cutting, planning, assembling, and fitting hinges, hasps and staples; and finishing skills of sanding and varnishing. The third phase (evaluation, and marketing promotion) was planned to be covered in three weeks, and planned to use the same activities as the example lesson plan format (see Figure 6.3).

Ronald’s lesson plan, intended for his Form Five technology class (as shown in Figure 7.11), was also based on the example lesson plan format introduced during the workshop in 2006. His lesson plan was organised under task definition, generic learning outcomes stated as overall dimension of technology and specific learning outcomes written under conceptual, procedural, technical, and societal aspects.

Figure 7.11
Ronald’s lesson plan

| Planning for Learning in Technology Education | | | |
|---|--|---|---|
| Task Definition Design and construct a stool to be used at school. | | | |
| Overall Dimension of Technology Conceptual – Examine the key principles of designing stools Procedural – Use the require procedures for designing and constructing of the stool Technical – Demonstrate technical drawing skills and basic hand tool technical skills Societal – Identify the range of preferences people have for where should the stool be used at school. | | | |
| Conceptual Learning Outcomes | Procedural Learning Outcomes | Technical Learning Outcomes | Societal Learning Outcomes |
| Understand that - Balance and strength are important principles when designing a stool. - Aesthetic and ergonomics are the key principles to be considered when designing a product to be used as a piece of furniture | Understand the procedures for: - Drawing an isometric and orthographic view of the stool - Using a design folio - Constructing the stool from start to finish - Using require tools such as tape measure, hand saw, chisel - Evaluating the stool | Be able to: - Do technical drawings – isometric and orthographic views - Do technical skills such as: marking out, cutting with handsaw, chiselling, sanding, and varnishing. | Understand that different people have different preferences for where the stool should be used in the school. |

According to Ronald's lesson plan, his defined task was to design and construct a stool to be used at school. Ronald picked up this task because it was his Form Five technology task which was focused on meeting examination requirements. His students were designing and making a stool to replace the broken stools in the industrial arts. This was Ronald's existing task which he already started in the first semester. However, with the lesson plan format he was able to outline his learning outcomes. Ronald's generic learning outcomes under conceptual were based on key principles for designing wooden stools, and his procedural dimension was based on designing and construction of the stool. His technical dimension was focused on technical drawing skills and hand skills for constructions. Under societal dimension, he included people's preferences.

Ronald's specific learning outcomes were also derived from his generic learning outcomes stated as overall dimensions of technology. Under conceptual, he had two specific learning outcomes which focused on understanding the principles of strength and balance and the principles of aesthetics and ergonomics. A total of five specific learning outcomes were written under procedural which focused on firstly, the technical drawing procedures (Isometric and Orthographic views); secondly, the layout of the design folio; thirdly, the construction procedure; fourthly, the procedures for using specific tools; and lastly, the project evaluation procedures. Under technical, he stated two learning outcomes which were the technical skills of drawing an isometric and an orthographic view; and the technical skills for using various hand tools. Finally, the students should be able to understand that different people had different preferences as this was the focus of the societal learning outcome.

Ronald's planned programme of work for the second semester of 2006 was also organised into weeks and under the three phases of the design process (investigation, design and devising phase, the construction phase, and the evaluation and marketing promotion phase) as shown in Figure 7.12.

Figure 7.12
Ronald's programme of work

Semester two Unit Planner - 2006

| Weeks | Design Process Phases | Activities |
|---------|--|--|
| Week 1 | Investigation, Designing and Devising ↓ | Identify context – Real life situation, News papers, Community based information etc |
| | | Brain storm – to identify & select the technological task |
| Week 2 | | Develop design brief or task definition |
| | | Identify the appropriate strands (learning areas) related to the task defined |
| | | Consider the stake holders involved and include them in the investigation process |
| | | List specifications required for constructing the task |
| Week 3 | | Devising initial ideas |
| | | Designing the initial concepts – 2D/3D – Drawing skills |
| Week 4 | | Technical drawing skills – Orthographic & Pictorial - Isometric/oblique |
| | | More investigation and research – Technological & societal knowledge/concepts |
| | | • Interviews/surveys – develop questionnaires |
| Week 5 | | Recorded/researched notes - Communication skills |
| | | Identify relevant technological / scientific concepts related to the product |
| | | • Note taking – uses of the product, required design & scientific principles |
| | | • Research and note taking - |
| Week 6 | | Reassess/evaluate the designing and devising process |
| | | • Self/peer analysis |
| | | • Teacher/client analysis |
| Week 7 | Construction Phase ↓ | Students construct their designed products |
| | | Knowledge/skills to be taught/learnt |
| Week 8 | | - measuring and cutting of the timbers into require lengths |
| | | Knowledge/skills to be taught/learnt |
| | | - Planning to required thickness |
| Week 9 | | Knowledge/skills to be taught/learnt |
| | | Cutting and chiseling the joints for the wooden frame |
| Week 10 | | Knowledge/skills to be taught/learnt |
| | | Marking out, cutting and planning of the wood board for the stool top |
| Week 11 | ↓ | Knowledge/skills to be taught/learnt |
| | | Sanding |
| Week 12 | | Knowledge/skills to be taught/learnt |
| | | varnishing of the wooden top |
| Week 13 | Evaluation and marketing promotion ↓ | Evaluation of the project |
| | | Students' final assessment of their task as they reflected on their finish task |
| Week 14 | | Final presentation |
| Week 15 | | Promotion and Marketing |

Ronald planned his programme of work to be covered in 15 weeks of the second semester of 2006. Unlike the rest of the teachers, Ronald's students had already completed the design aspects in semester one following the format prescribed by the MoE, although Ronald used this lesson plan format to outline his lesson sequence. However, he decided to stick with the timing of six weeks to cover the first phase of the design process (investigation, design and devising) and also decided to use the same activities as in the example programme of work (see Figure 6.3). The activities were identifying the context, developing design brief and specifications, developing initial ideas using 2D and 3D technical drawings, investigating and researching more ideas, taking related notes, reassessing and evaluating the initial design idea or concepts. In semester two, his students were ready to work on the construction phase, which was planned to be completed in six weeks, and the evaluation and marketing promotion phase to be done in three weeks. It also used the activities in the example lesson plan (see Figure 6.3).

Appendix P

Observation: 2

The Technology Education Unit

This unit is on development plans under technical drawing. Anthony had decided to teach his students how to make a development plan of a funnel using an A4 size paper. So the teacher's objective is, at the end of this lesson, students should be able to draw a development plan of a funnel and be able to make it as a model funnel using a piece of A4 size paper. This task is expected to be completed in a 40 minute period.

| <i>Teacher's Actions</i> | <i>Students' Actions</i> | <i>Researcher Commentary</i> |
|--|--|---|
| <p>Teacher introduced the lesson to the students by telling them the activity for that period. The teacher explained that their project for that class was about making a funnel and it would be made out of an A4size paper.</p> <p>The teacher began this lesson by writing down the notes on working procedures for making the development plan on the blackboard, so students could follow. The teacher wrote down each working procedures step by step on the blackboard as he went along.</p> <p>After the teacher completed writing notes on the blackboard he immediately moved on to further clarify the notes. By doing so, the teacher went thoroughly through the notes again step by step as he gave students the instructions on how to go about drawing the development plans and making of the funnel. The teacher used the blackboard to explain the working procedures as he drew a development plan on the blackboard.</p> <p>Then the teacher asked the students if they had any questions in regard to the note or whether they had already understood the work</p> | <p>Students listened very attentively, as the teacher informed them about their class activity for that period.</p> <p>Students copied the notes into their exercise books as the teacher wrote down the notes on the blackboard</p> <p>All students were still copying notes from the blackboard when the teacher started explaining the contents of the notes as well as giving instructions on how to make the funnel.</p> <p>There was no respond from the students, as some students were still coping notes.</p> | <p>The teacher's introduction was brief and the students were eager to find out what their task for the day would be and they were keen to get on with the work.</p> <p>The teacher did not prepare this note in advance so he had to write it on the board for students to copy it in their exercise books. This exercise took about ten minutes of the class time.</p> <p>Because the students had not completed their note taking, they were not really paying much attention to the teacher's explanations and instructions. This scenario did not bother the teacher at all as the teacher continued to explain the procedures by using the blackboard for drawing a development plan of a funnel.</p> |

| | | |
|---|---|---|
| <p>After the teacher had explained the notes, he then repeated the procedures again step by step. This time he demonstrated each step to the students on how to draw a development plan on an A4 size paper. After he had done the drawing, he then use the scissors to cut out the plan and then folded it into a funnel shape before he glued it together. While the teacher was doing the demonstration, he talked to the students about time which is an important issue in the western societies but it's not an issue in the Solomon Islands.</p> | <p>The students had been closely watching the teacher's demonstration on how to follow the procedures to be able to make the funnel. By the time the teacher demonstrated the procedures using the A4 size paper, all students have already completed their note takings. Therefore much attention was give to the teachers' demonstration.</p> | <p>This was the third time the teacher talked again about the working procedures. By this time most students were paying more attention to the teacher's demonstrations on the working procedures. The teacher spend almost half of this class period just went working procedures by using three different forms of explanations, such as; firstly, by verbally explained each step one by one, secondly, by drawing a development plan on the board to illustrate each step, and thirdly, by actually drawing the development plan on an A4 size paper and demonstrated how to cut it and folded to make a funnel. As the teacher did his demonstration he knew time had been catching up on him so he started talking about time which was very much unrelated to the demonstration. The teacher spent most of this class time on the explanations, illustrations, and demonstrations of the procedures on drawing a development plan and making of the paper funnel</p> |
| <p>Then the teacher handed out a piece of A4 size paper to each individual student and asked them to follow the working procedures outlined on the blackboard on how to make a paper funnel from a drawn development plan with the given piece of A4 size paper.</p> | <p>Students then started drawing their development plans of a funnel on the A4 size paper following the procedures outlined on the blackboard. After the students had drawn their development plan they then began to cut it out and folded it up and glued both ends together to form a complete funnel.</p> | <p>As a result of the teacher spending too much time on the blackboard as he went through this process with the students, only a few minutes of the class time had been left by the time the students were given the task to start with the construction of the funnel.</p> |
| <p>As the students were working on their paper funnels, the teacher moved around the classroom checking on students work and assisting few students who had difficulties with drawing of the development plan. The teacher continued doing this until he released the class well after some extra time</p> | <p>Students continued to work on their own as from an interview they acknowledged the teacher's explanations and demonstrations were very clear.</p> | <p>During these few minutes most students had been working independently as the working procedures were very clear after they had had the numerous explanations, and demonstrations given by the teacher through out the first part of the class.</p> |

| | | |
|---|--|--|
| <p>beyond the normal class time.</p> <p>During the extra time, the teacher collected each individual student's work soon as they were completed. Soon as the rest of the other students had completed their paper funnels, the few tools which were used by the students were also collected and stored away in the teacher's office.</p> | <p>The students continued this process through out the remaining class time until they had actually completed their funnels, and handed it to the teacher.</p> | <p>The sharing of the only few available tools, like 1 scissors, 2 compasses and so forth, between 23 students in a classroom had also contributed to the delay of students completing their work within the 40 minute class period.</p> |
|---|--|--|

High school teacher involvement in demonstrating to the class
The teacher spent too much time on the black board
So much teacher centred teaching/the teacher is rushing against time.

Tools are few and students are sharing the tools e.g. one scissors shared between 20 students.