



THE UNIVERSITY OF  
**WAIKATO**  
*Te Whare Wānanga o Waikato*

Research Commons

<http://waikato.researchgateway.ac.nz/>

## Research Commons at the University of Waikato

### Copyright Statement:

The digital copy of this thesis is protected by the Copyright Act 1994 (New Zealand).

The thesis may be consulted by you, provided you comply with the provisions of the Act and the following conditions of use:

- Any use you make of these documents or images must be for research or private study purposes only, and you may not make them available to any other person.
- Authors control the copyright of their thesis. You will recognise the author's right to be identified as the author of the thesis, and due acknowledgement will be made to the author where appropriate.
- You will obtain the author's permission before publishing any material from the thesis.

# THE EFFECT OF MANUKA HONEY ON ENTEROBACTERIA



THE UNIVERSITY OF  
**WAIKATO**  
*Te Whare Wānanga o Waikato*

A thesis submitted in fulfilment  
of the requirements for the degree of  
Doctor of Philosophy in  
Biological Sciences at  
the University of Waikato

by

SHIH-MIN LIN

2010

## ABSTRACT

---

Manuka honey (*Leptospermum scoparium*) produced in New Zealand has been shown to exhibit substantial antibacterial activity against a broad range of pathogens causing wound infection, and is being used in wound management with excellent results. This activity is due to both hydrogen peroxide and non-peroxide components. Manuka honey, however, may not be useful for treating bacterial gastroenteritis because the gastrointestinal environment may be unfavourable to the antibacterial action, and because a sufficiently high concentration for effectiveness may not be achieved. The research in this thesis is set out to evaluate *in vitro* the efficacy of manuka honey as an antibacterial agent against enterobacteria, taking into consideration some factors that may be involved in the gastrointestinal environment.

Because some gastrointestinal bacteria (*Campylobacter* spp., *Helicobacter pylori*, *Lactobacillus* spp. and *Bifidobacterium animalis* subsp. *lactis*) are not aerophilic, a cheap yet acceptable gas generating system alternative to the commercial gaspack counterpart was sought for use in this study. Various alternatives were compared for their performance. The spirits burn method was chosen for cultivating microaerobes and some anaerobes because of its comparable performance to that of commercial systems in terms of the growth of bacterial species, and because of the ease of use and the low cost.

In the first part of this thesis, the susceptibility of gastrointestinal bacteria against manuka honey was investigated by determining the minimum inhibitory concentration (MIC) and minimum bactericidal concentration (MBC) using a standardised manuka honey. Throughout the research, a manuka honey with median level non-peroxide antibacterial activity (equiv-

alent to that of 16.5% phenol) was used, except that *Campylobacter* spp. were assayed with a more potent manuka honey equivalent to 29.4% phenol. The measured sensitivity of bacteria showed that manuka honey is significantly more effective than artificial honey (a mixture sugars as in honey), indicating that osmolarity is not the only factor that is responsible for the antibacterial activity of the honey. It was found that some species of bacteria *e.g.* *Campylobacter* spp. are exceptionally sensitive to manuka honey (both MIC and MBC are about 1% honey solution), whereas most other gastrointestinal pathogens have MIC and MBC values in the range 5–10% honey other than *Enterobacter* and *Pseudomonas* which were in the range 10–17%. *Bifidobacterium*, lactobacilli and enterococci appear to be more tolerant to the honey (MIC: 9.36–14.29%; MBC:  $\geq 13.3\%$ ) than most other species are. The difference in efficacy between the honey with and without hydrogen peroxide removed was also studied, and it was found that both hydrogen peroxide and the non-peroxide components contribute to the bacteriostatic and bactericidal activity of the honey.

Because oxygen is required for hydrogen peroxide to be produced in honey, the role that oxygen plays in the antibacterial activity of manuka honey was investigated by analysing the susceptibility data obtained under both aerobic and anaerobic conditions using facultative anaerobes. Manuka honey appeared to be a more potent bacteriostatic agent against most species of bacteria in the absence of oxygen, whereas a relatively higher concentration of manuka honey solution was required to kill some bacteria under anaerobic conditions. This may partially be due to the atmosphere having also affected the metabolism, and hence the growth, of bacteria. Therefore, the activity of manuka honey would not necessary decline in the intestinal environmental atmosphere.

To investigate how long it takes for manuka honey to kill bacteria, time-to-kill studies were conducted by monitoring the survival of bacteria

in manuka honey. It is found that it takes a 20% solution of manuka honey with a medium-level activity more than 6 h to kill 90% of the cells of most of the species tested if the bacterial cells are kept in contact with the honey. This suggests that manuka honey is not rapidly bactericidal, and that it is unlikely to be possible to fully eradicate a bacterial gut infection by ingesting a small amount of manuka honey for a short period. It was found that probiotics can survive in the 20% honey solution for more than 12 h.

The pharmacodynamics of the antibacterial activity of manuka honey were studied to investigate the survival and the re-growth of bacteria after they had been treated with honey. It was revealed that after being exposed to manuka honey for a short term (1 h), the growth of most enteropathogens is slowed for approximately 2–4 h before it gets back to a full rate. The assays of this postantibiotic effect also showed that the latency in the re-growth after being exposed to honey is not proportional to the MIC, MBC or time-to-kill profiles.

Finally, the efficacy of manuka honey on bacteria was studied under conditions simulating the environment in the stomach and intestines. The tested bacteria were unable to grow under the acidic conditions as in the stomach, so whether or not the honey had any antibacterial activity under these conditions could not be determined. Under the conditions simulating the intestinal environment, the results demonstrated that the antibacterial activity of manuka honey is slightly decreased in the mildly alkaline conditions of the intestine (pH 7.5). In the presence of pancreatin and bile at the same pH, the activity of manuka honey was found to decrease by more than 50%. This suggests that pancreatin and bile in the gut may negatively affect the efficacy of the antibacterial activity of manuka honey *in vivo*. This indicates that although ingested manuka honey may still have some antibacterial action when in the gut, the antibacterial activity would

be different from that which is usually examined with sensitivity studies *in vitro*.

Gastroenteritis has generally been treated with oral rehydration solution (ORS) that consists of carbohydrates and electrolytes. Manuka honey could be used instead of the usual carbohydrate component of ORS and would provide additional bioactivities such as antibacterial activity and stimulation of growth of probiotics, which would make the honey rehydration solution more beneficial to patients with gastroenteritis than is the traditional ORS. After some initial investigation to find the most appropriate dosage and frequency of doses, a clinical trial may be warranted.

## ACKNOWLEDGEMENTS

---

First of all, I would thank Prof. Peter Molan - my admirable chief supervisor on honey and biochemistry who always wants to help everyone (and therefore always keeps himself busy even on holidays). Not only did he give valuable suggestion on and beyond my research during my study, help enormously on polishing and formatting my work, but he also always could find some way to encourage me, which had been an essential motivation for me for the last few years.

Equally important is Dr. Ray Cursons - my secondary supervisor on microbiology and molecular biology. Without his suggestions I would not have been able to handle some difficult bacteria. Not only did he give me prompt advice and answers to my questions, but he also made me to be able to think an aspect from different angles.

Thanks to Ms. Kerry Allen - the technical officer and the angel of the Honey Research Unit and of the Department. She was also my (unofficial) third supervisor.

Thanks to Dr. Barry O'Brien - without his help I would not be able to have the professional photographs of agar plates in my thesis.

Thanks to Dr. Judi McWhirter - statistician from Dept. Statistics, University of Waikato for advice on research analytical method.

Thanks to Ms. Chris Pickett and staff in Medlab, Hamilton, New Zealand - for providing *Campylobacter*, *Salmonella*, *Yersinia* and *Haemophilus* clinical isolates.

Thanks to Dr. Anthony Smith and Dr. Christopher Mansell from the Waikato Hospital, who led me to contact Mr. Murray Robinson, Microbiology

Charge Scientist from Pathlab Bay of Plenty, for collecting *Clostridium difficile* clinical isolates.

Thanks to Dr. On Stephen - Head of Food Safety Programme from the Institute of Environmental Science & Research (ESR), for advice on *Campylobacter* and *Helicobacter*.

Thanks to Ms. Lynne Baxter - glasshouse technician in the Department, for sharing her experience and encouraging me during my study.

Thanks to Mr. Colin Monk - technician from the Thermophile Research Unit, for assisting me in the use of the anaerobic gas chamber.

Dr. Sangmi Han, Dr. Nikki Harcourt, Dr. Petrel Zhou, Helene Brangouro, Anne van Brussel, Kathrine Endress, Kim von Dorenmaren, Emma Littlejohn, Stacey Meyer and Syaliza Omar - my friends in the lab for providing some spice in my life during my study.

Thanks to the Department of Biological Sciences for providing me with a part time job. Also thanks to the plants (esp. carnivorous plants) at the glasshouse for “staying” with me during weekends.

Thanks to Yuri Robbers from Department of Biology, Leiden University, The Netherlands - without his big help on L<sup>A</sup>T<sub>E</sub>X 2<sub>ε</sub>, I could not have sorted out some technical problems by the due date.

Thanks to The Awsomes - my yet another “family” in New Zealand. You guys are definitely awesome. Also thanks to many other friends that regrettably could not be fully listed.

Last but not least, my biggest thank should go to my family. Without their support and encouragement I could not have been what I am and where I am now.



# CONTENTS

---

1	Introduction and literature reviews	1
1.1	The digestive system	2
1.1.1	The mouth	3
1.1.2	The stomach	3
1.1.3	The intestines	5
1.2	Gastrointestinal diseases	8
1.3	Gastrointestinal pathogens	10
1.3.1	<i>Salmonella</i> spp.	10
1.3.2	<i>Enterobacteriaceae</i>	11
1.3.3	<i>Campylobacter</i> spp.	13
1.3.4	<i>Helicobacter</i> spp.	15
1.3.5	<i>Clostridium difficile</i>	16
1.4	Gastroenteritis treatments	18
1.4.1	Oral rehydration solution	18
1.4.2	Probiotics	18
1.4.3	Antibiotics	21
1.5	Honey - a “re-discovered” therapy	24
1.5.1	Composition and properties of honey	25
1.5.2	The antibacterial activity of honey	26
1.5.3	Reported use of honey for treating gastroenteritis	34
1.5.4	Honey and gastrointestinal pathogens	35
1.5.5	Honey and probiotics	42
1.5.6	Possible mechanisms that may be involved in the treatment of gastroenteritis with honey	44

1.6	Intention of this research project . . . . .	46
2	General materials and methods . . . . .	48
2.1	Culture media . . . . .	49
2.1.1	Trypticase soy broth (TSB) . . . . .	49
2.1.2	Nutrient agar (NA) . . . . .	49
2.1.3	Mueller-Hinton broth (MHB) . . . . .	49
2.1.4	Reinforced clostridial medium (RCM) . . . . .	50
2.1.5	Cooked meat broth . . . . .	50
2.1.6	de Man Rogosa and Sharpe medium (MRS) . . . . .	51
2.1.7	Brain heart infusion yeast extract medium (BHIYE) . . . . .	51
2.1.8	Columbia horse blood <i>Helicobacter pylori</i> agar (CHBHP) . . . . .	51
2.1.9	Haemophilus medium base agar (HMB) . . . . .	52
2.1.10	Enriching with defibrinated sheep/horse blood and heat-inactivated horse serum . . . . .	53
2.1.11	Campylobacter blood-free selective agar . . . . .	53
2.1.12	Ferrous sulfate-sodium metabisulfite-sodium pyruvate (FBP) supplement . . . . .	54
2.1.13	Modified Christensen's urea test broth . . . . .	54
2.2	Bacterial cultures . . . . .	55
2.3	Honey samples . . . . .	59
2.4	Multiplex PCR . . . . .	60
2.5	Honey activity identification . . . . .	62
2.5.1	Type culture preparation . . . . .	62
2.5.2	Seeded square agar plate preparation . . . . .	62
2.5.3	Antibacterial activity test . . . . .	63
2.6	The track dilution method . . . . .	64
3	Spirits burn method for culturing non-aerobic organisms . . . . .	67
3.1	Introduction . . . . .	68

3.2	Gas generating systems evaluated . . . . .	70
3.2.1	AnaeroPack system . . . . .	70
3.2.2	CO <sub>2</sub> incubator . . . . .	70
3.2.3	Candle jar . . . . .	70
3.2.4	Spirits burn method . . . . .	71
3.3	Comparison of the growth of non-aerobes . . . . .	71
3.3.1	Bacterial cultures and media . . . . .	71
3.3.2	Culture preparation . . . . .	71
3.3.3	Comparison of the gas generating systems . . . . .	72
3.3.4	Results . . . . .	73
3.4	The comparison of the growth of anaerobes . . . . .	74
3.4.1	Bacterial cultures and media . . . . .	74
3.4.2	Results . . . . .	77
3.5	Discussion . . . . .	77
3.6	Safety issues . . . . .	82
3.7	Conclusion . . . . .	84
4	Susceptibility of enterobacteria to honey . . . . .	85
4.1	Introduction . . . . .	86
4.1.1	Honey and gastrointestinal pathogens . . . . .	86
4.2	Materials and methods . . . . .	87
4.2.1	Honey samples used in this study . . . . .	87
4.2.2	Bacterial strains and culture media used in this study . . . . .	88
4.2.3	Cell density control . . . . .	88
4.2.4	Honey preparation . . . . .	89
4.2.5	Honey serial dilution . . . . .	90
4.2.6	MIC and MBC determination . . . . .	91
4.3	Statistical analysis . . . . .	92
4.4	Results . . . . .	93

4.4.1	Facultative anaerobes . . . . .	93
4.4.2	Microaerobes . . . . .	93
4.4.3	Anaerobes . . . . .	96
4.4.4	Probiotics . . . . .	96
4.5	Discussion . . . . .	97
4.5.1	Facultative anaerobes . . . . .	98
4.5.2	Microaerobes . . . . .	100
4.5.3	<i>Clostridium difficile</i> . . . . .	104
4.5.4	Probiotics . . . . .	105
4.6	Conclusion . . . . .	108
5	The Effect of Atmosphere . . . . .	109
5.1	Introduction . . . . .	110
5.2	Materials and method . . . . .	112
5.3	Results and discussion . . . . .	114
6	The pharmacodynamics of manuka honey . . . . .	122
6.1	Introduction . . . . .	123
6.2	Materials . . . . .	128
6.2.1	Bacterial strains . . . . .	128
6.2.2	Culture media . . . . .	129
6.2.3	Diluent broth for serial dilution . . . . .	129
6.3	Time-to-kill analysis . . . . .	129
6.3.1	Methods . . . . .	130
6.3.2	Results . . . . .	130
6.3.3	Discussion . . . . .	131
6.4	The post-antibiotic effect of manuka honey on organisms . . . . .	139
6.4.1	Methods . . . . .	140
6.4.2	Results and discussion . . . . .	143

6.4.3	A spectrophotometric method for the post-antibiotic assay - a trial . . . . .	154
7	Gastrointestinal acidity and enzyme . . . . .	162
7.1	Introduction . . . . .	163
7.2	The effect of acidity on the antibacterial activity of manuka honey . . . . .	165
7.2.1	Materials and method . . . . .	165
7.2.2	Results and discussion . . . . .	167
7.3	The effect of gastrointestinal enzymes on the activity of manuka honey . . . . .	176
7.3.1	Materials and method . . . . .	177
7.3.2	Results and discussions . . . . .	180
7.4	Conclusion . . . . .	191
8	General discussion . . . . .	192
8.1	The antibacterial efficacy of standardised manuka honey . . . . .	193
8.2	Environmental stress and the efficacy of antibacterial agents . . . . .	199
8.3	Methylglyoxal in manuka honey . . . . .	202
8.4	Conclusion . . . . .	205
8.5	Future work . . . . .	206
8.5.1	Enteropathogens other than common gastrointestinal pathogens . . . . .	206
8.5.2	The efficacy of honey on viral gastrointestinal disease . . . . .	207
8.5.3	The efficacy of honey on protected enteropathogens . . . . .	207
8.5.4	Pharmacodynamics . . . . .	208
8.5.5	The effect of honey on probiotics . . . . .	210
8.5.6	The mechanism of the non-peroxide antibacterial activity in manuka honey . . . . .	212

Bibliography	214
Appendix	262

## LIST OF FIGURES

---

1.1	The secretion and absorption of fluid in the gastrointestinal tract. . . . .	7
2.1	The square agar plate with a numbered quasi-Latin square template for antimicrobial activity testing. . . . .	63
2.2	The serial diluted culture spread on a square agar plate. . . . .	66
3.1	The growth rates of micro-organisms when cultured in broth under different atmospheres. . . . .	75
3.2	Colony diameter when cultured in different atmospheres. . . . .	76
3.3	An explanation of why the “candle jar” is unstable. . . . .	79
5.1	The comparison of the result of agar diffusion assay in the aerobic and anaerobic (GasPak) conditions. . . . .	112
6.1	The decline in the viable cell number of <i>Escherichia coli</i> on incubation in solutions of manuka honey. . . . .	132
6.2	The decline in the viable cell number of <i>Salmonella typhimurium</i> DT104 on incubation in solutions of manuka honey. . . . .	132
6.3	The decline in the viable cell number of <i>Salmonella enteritidis</i> on incubation in solutions of manuka honey. . . . .	133
6.4	The decline in the viable cell number of <i>Pseudomonas aeruginosa</i> on incubation in solutions of manuka honey. . . . .	133
6.5	The decline in the viable cell number of <i>Yersinia enterocolitica</i> on incubation in solutions of manuka honey. . . . .	134
6.6	The decline in the viable cell number of <i>Enterobacter aerogenes</i> on incubation in solutions of manuka honey. . . . .	134

6.7	The decline in the viable cell number of <i>Enterobacter cloacae</i> on incubation in solutions of manuka honey. . . . .	135
6.8	The decline in the viable cell number of <i>Shigella flexneri</i> on incubation in solutions of manuka honey. . . . .	135
6.9	The decline in the viable cell number of <i>Shigella sonnei</i> on incubation in solutions of manuka honey. . . . .	136
6.10	The decline in the viable cell number of <i>Enterococcus faecalis</i> on incubation in solutions of manuka honey. . . . .	136
6.11	The decline in the viable cell number of <i>Enterococcus faecium</i> on incubation in solutions of manuka honey. . . . .	137
6.12	An illustrative graph of the calculation of the postantibiotic effect (PAE). . . . .	143
6.13	The postantibiotic effect of manuka honey on <i>E. coli</i> . . . . .	144
6.14	The postantibiotic effect of manuka honey on <i>S. typhimurium</i> DT <sub>104</sub> . . . . .	145
6.15	The postantibiotic effect of manuka honey on <i>S. enteritidis</i> . . . . .	145
6.16	The postantibiotic effect of manuka honey on <i>P. aeruginosa</i> . . . . .	146
6.17	The postantibiotic effect of manuka honey on <i>Y. enterocolitica</i> . . . . .	146
6.18	The postantibiotic effect of manuka honey on <i>E. aerogenes</i> . . . . .	147
6.19	The postantibiotic effect of manuka honey on <i>E. cloacae</i> . . . . .	147
6.20	The postantibiotic effect of manuka honey on <i>S. flexneri</i> . . . . .	148
6.21	The postantibiotic effect of manuka honey on <i>S. sonnei</i> . . . . .	148
6.22	The postantibiotic effect of manuka honey on <i>E. faecalis</i> . . . . .	149
6.23	The postantibiotic effect of manuka honey on <i>E. faecium</i> . . . . .	149
6.24	The postantibiotic effect of manuka honey on <i>Bifidobacterium animalis</i> subsp. <i>lactis</i> . . . . .	150
6.25	The postantibiotic effect of manuka honey on <i>Lactobacillus plantarum</i> . . . . .	150



6.26	The postantibiotic effect of manuka honey on <i>Lactobacillus rhamnosus</i> . . . . .	151
6.27	A dot plot of data from the MIC, MBC, time-to-kill and postantibiotic effect (PAE) tests with manuka honey M115. . . . .	153
6.28	Theoretical graph of postantibiotic effect (PAE) determination using spectrophotometry. . . . .	155
6.29	Growth curves monitored by a microtiterplate reader of <i>E. coli</i> culture after 1 hour exposure of 5% honey. . . . .	156
6.30	Growth curves monitored by a microtiterplate reader of <i>E. coli</i> culture after 1 hour exposure of 10% honey. . . . .	157
6.31	Growth curves monitored by a microtiterplate reader of <i>E. coli</i> culture after 1 hour exposure of 20% honey. . . . .	158
7.1	The effect of pH on the MIC and MBC of manuka honey M115 and artificial honey against <i>E. coli</i> . . . . .	168
7.2	The effect of pH on the MIC and MBC of manuka honey M115 and artificial honey against <i>S. typhimurium</i> DT104. . . . .	168
7.3	The effect of pH on the MIC and MBC of manuka honey M115 and artificial honey against <i>S. enteritidis</i> . . . . .	169
7.4	The effect of pH on the MIC and MBC of manuka honey M115 and artificial honey against <i>P. aeruginosa</i> . . . . .	169
7.5	The effect of pH on the MIC and MBC of manuka honey M115 and artificial honey against <i>Y. enterocolitica</i> . . . . .	170
7.6	The effect of pH on the MIC and MBC of manuka honey M115 and artificial honey against <i>S. flexneri</i> . . . . .	170
7.7	The effect of pH on the MIC and MBC of manuka honey M115 and artificial honey against <i>S. sonnei</i> . . . . .	171
7.8	The effect of pH on the MIC and MBC of manuka honey M115 and artificial honey against <i>E. aerogenes</i> . . . . .	171

7.9	The effect of pH on the MIC and MBC of manuka honey M <sub>115</sub> and artificial honey against <i>E. cloacae</i> . . . . .	172
7.10	The effect of pH on the MIC and MBC of manuka honey M <sub>115</sub> and artificial honey against <i>E. faecalis</i> . . . . .	172
7.11	The effect of pH on the MIC and MBC of manuka honey M <sub>115</sub> and artificial honey against <i>E. faecium</i> . . . . .	173
7.12	Comparison of the MIC and MBC of manuka honey against <i>E. coli</i> in various digestive environments. . . . .	182
7.13	Comparison of the MIC and MBC of manuka honey against <i>P. aeruginosa</i> in various digestive environments. . . . .	183
7.14	Comparison of the MIC and MBC of manuka honey against <i>Y. enterocolitica</i> in various digestive environments. . . . .	183
7.15	Comparison of the MIC and MBC of manuka honey against <i>S. typhimurium</i> DT <sub>104</sub> in various digestive environments. . . . .	184
7.16	Comparison of the MIC and MBC of manuka honey against <i>S. enteritidis</i> in various digestive environments. . . . .	184
7.17	Comparison of the MIC and MBC of manuka honey against <i>E. faecalis</i> in various digestive environments. . . . .	185
7.18	Comparison of the MIC and MBC of manuka honey against <i>E. faecium</i> in various digestive environments. . . . .	185
7.19	Comparison of the MIC and MBC of manuka honey against <i>E. aerogenes</i> in various digestive environments. . . . .	186
7.20	Comparison of the MIC and MBC of manuka honey against <i>E. cloacae</i> in various digestive environments. . . . .	186
7.21	Comparison of the MIC and MBC of manuka honey against <i>S. flexneri</i> in various digestive environments. . . . .	187
7.22	Comparison of the MIC and MBC of manuka honey against <i>S. sonnei</i> in various digestive environments. . . . .	187
8.1	The chemical structure of methylglyoxal (MGO). . . . .	202

8.2 Methylglyoxal metabolism in organisms. . . . . 203

## LIST OF TABLES

---

1.1	Water activity and growth of microorganisms in food. . . . .	27
1.2	Published sensitivity of enteropathogens to honey. . . . .	36
2.1	The bacterial cultures used in this study. . . . .	56
2.2	Bacterial strains and culture media used in the susceptibility test. . . . .	59
2.3	Oligonucleotide primers and their amplicon sizes used in this study. . . . .	61
3.1	Incubation conditions for the comparison of non-aerobic culture systems. . . . .	72
3.2	Incubation conditions for the comparison of anaerobic culture systems. . . . .	76
3.3	Growth of anaerobes in different gas systems. . . . .	78
3.4	Cost comparison between gas generating systems. . . . .	83
4.1	The final concentration of honey in each microplate well after serial dilution and inoculating cultures. . . . .	91
4.2	The minimum inhibitory and bactericidal concentrations (% v/v) of manuka honey M115 and artificial honey for non-fastidious gastrointestinal pathogens. . . . .	94
4.3	The minimum inhibitory concentration (% v/v) of manuka honey and artificial honey for microaerobes. . . . .	95
4.4	The minimum inhibitory and bactericidal concentrations (% v/v) of manuka honey M113 and artificial honey for <i>Clostridium difficile</i> . . . . .	96

4.5	The minimum inhibitory and bactericidal concentrations (% v/v) of manuka honey M115 and artificial honey for the normal flora in the gastrointestinal tract. . . . .	97
5.1	The results of the effect of atmosphere on the MIC (% v/v) of manuka honey, manuka honey plus catalase, and artificial honey. . . . .	115
5.2	The results of the effect of atmosphere on the MBC (% v/v) of manuka honey, manuka honey plus catalase, and artificial honey. . . . .	116
7.1	The environments for evaluating the effect of intestinal enzyme on honey. . . . .	179

## ABBREVIATIONS

---

AAD	Antibiotic-Associated Diarrhoea
ANOVA	Analysis of Variance
$a_w$	Water Activity
BHIYE	Brain Heart Infusion Yeast Extract
CDAD	<i>Clostridium difficile</i> -Associated Diarrhoea
CFU	Colony-Forming Unit
CHRO	<i>Campylobacter, Helicobacter</i> and Related Organisms
DHA	Dihydroxyacetone
ESR	Institute of Environmental Science & Research
FBP	Ferrous sulphate-Sodium metabisulfite-Sodium pyruvate
MBC	Minimum Bactericidal Concentration
MHB	Mueller-Hinton Broth
MGO	Methylglyoxal
MRS	de Man Rogosa and Sharpe
MRSA	Methicillin-Resistant <i>Staphylococcus aureus</i>
OD	Optical Density
ORS	Oral Rehydration Solution
ORT	Oral Rehydration Therapy

PAE	Post-Antibiotic Effect
PCR	Polymerase Chain Reaction
PPI	Proton Pump Inhibitor
RCM	Reinforced Clostridial Medium
ROS	Reactive Oxygen Species
SCFA	Short-Chain Fatty Acid
SGF	Simulated Gastric Fluid
SIF	Simulated Intestinal Fluid
TSB	Trypticase Soy Broth
UMF	Unique Manuka Factor
VBNC	Viable But Not Culturable
VRE	Vancomycin-Resistant <i>Enterococci</i>

## INTRODUCTION AND LITERATURE REVIEWS

---

This chapter first gives a general introduction to gastroenteritis, followed by giving four parts of literature review - the human digestive system, gastroenteritis and its associated bacteria, commonly used therapies and their limitations, and the medical use of honey. The possibility is also discussed that the gastro-intestinal environment may affect the antibacterial activity of manuka honey, and therefore the *in vitro* activity may not reflect the actual efficacy in gastro-intestinal infection.

Lastly, the intentions of this thesis, that the assessment of the sensitivity of enteropathogenic bacteria to the antibacterial activity of manuka honey, and the assessment of the effect of gastro-intestinal environmental factors on the antibacterial activity of manuka honey, are introduced.



Gastroenteritis is an inflammation in the gastrointestinal tract that results in acute diarrhoea. In the world, millions of people are killed by improperly treated gastroenteritis each year (Kasper et al., 2005), and it is the leading cause of death among infants and children due to their impaired immunity (King et al., 2003). Most infectious gastro-intestinal diseases are known to be food-borne, *i. e.* invoked by ingesting “unfavoured” substances by the host along with food or drink water. Generally these “intruders” may not be able to cause disease as they would have to pass through a series of defensive barriers provided by the digestive system before any symptom can result.

## 1.1 The digestive system

This section first approaches an overview of the human digestive system, then the symptoms of gastrointestinal diseases frequently reported are reviewed. The content of this section is largely from Kasper et al. (2005) and Pocock and Richards (2006).

The digestive system consists mainly of the mouth, pharynx, oesophagus, stomach and intestines, with the accessory organs including the teeth, salivary glands, liver, gallbladder and pancreas. The system assists the movement of the ingested food, and at the same time secretes mucus and digestive juices to digest the food into small molecules that can be absorbed by the digestive tract into the bloodstream. Because of the chemical and enzymatic properties of the digestive juice, the digestive system also functions as a part of the defensive system against the microorganisms in food.

### **1.1.1 *The mouth***

The mouth is the entry for food and drink as well as for most microorganisms. When a person is ingesting food, the salivary glands secrete saliva, which mainly serves as a lubricant and also contains salivary  $\alpha$ -amylase (ptyalin), that starts digesting complex polysaccharides (*e.g.* starch and glycogen) into glucose, maltose, maltotriose and dextrans. Saliva also contains immunoglobulin A (IgA) and lysozyme. The latter acts on the cell walls of some bacteria to cause bacteriolysis or death of the cells. Individuals who lack functional salivary glands or in whom salivary secretion is impaired due to medication or therapy may suffer from dental caries or some diseases such as xerostomia. Approximately 1 500 ml of saliva is produced by the salivary glands each day.

### **1.1.2 *The stomach***

After food is swallowed, it passes through the pharynx and oesophagus into the stomach, where the food is temporarily stored and mechanically broken down to small particles.

The stomach secretes gastric juice which begins the digestive process of food in the body. Gastric juice is a mixture of salts, water, hydrochloric acid, pepsinogen (pepsin) and an intrinsic factors that is essential for the absorption of vitamin B<sub>12</sub> (cobalamin) by the mucosal epithelial cells of the lower ileum. In the stomach food is partially digested and most bacteria are considered to be eliminated. Clinical trials have shown that the secretion of gastric juice and its composition are related to the time that has elapsed since the ingestion of food. There is little or no fluid in the stomach during fasting whereas following meals, secretion of the constituents of gastric juice

increases progressively over the next 90 min or so. Approximately 2–3 l of gastric juice is secreted by gastric glands in adults each day.

The generation of gastric acid is driven by the  $H^+/K^+$ -ATPase proton pump system. It pumps hydrogen ions out of parietal cells by using energy derived from the hydrolysis of ATP, whereas chloride ions leave the cells either through a chloride channel in the secretory canaliculi, a tubular structure formed on parietal cell when food enter the stomach, or through a potassium-chloride symporter which transfers chloride through the membrane.

The pH of gastric acid is about 1–3. The highly acidic environment not only breaks down ingested food but also activates inactive pepsinogen into pepsin, an endopeptidase which shows greatest proteolytic activity at pH values below 3. HCl also aids the absorption of calcium and iron by dissolving insoluble salts of these minerals.

The stomach is fairly elastic due to its smooth muscle on the fundus and body of the stomach, and therefore is capable of accommodating a large volume of food. It has a volume of about 50 ml when empty whereas this can expand by approximately 80 times when it is fully distended.

To protect the stomach itself, the stomach creates a mucosal barrier which is contributed to by several factors. Firstly, the mucosal epithelial cells are tightly linked to each other, which prevent the gastric juice from leaking into the underlying layers of the tissue. Secondly, the epithelial cells and neck cells on gastric glands produce mucus that forms a thin layer of protective barrier. This mucus is alkaline because it contains bicarbonate and potassium secreted by the epithelial cells. Lastly, prostaglandin appears to play an important role on the protection by means of increasing the thickness of the mucus layer, stimulating the production of bicarbonate and improving the supply of nutrients to any damaged mucosal area. It is because of the viscous mucus that the lining of the stomach is not directly

contacted by the corrosive gastric juice, and only limited components such as alcohol and some drugs can pass through the mucus and be absorbed by the stomach.

On the other hand, direct contact of gastric juice with the stomach can result in inflammation of the underlying tissue, a condition known as gastritis which may lead to gastric ulcers. This is mainly caused by hypersecretion of hydrochloric acid or hyposecretion of the protective mucus. Many chemicals including caffeine, nicotine and some anti-inflammatory drugs alter the rate of acid and mucus production and this results in the stimulation of ulceration. The detergent actions of regurgitated bile acids or intestinal fluid may also break down the protective mucosal barrier. It is now also known that *Helicobacter pylori*, an acid-resistant bacterium, can adhere to gastric epithelial cells, destroy the mucus layer and thus cause peptic ulcers.

### **1.1.3 *The intestines***

Chyme, the food partially digested in the stomach, enters the intestines, which can be divided into the the small intestine and the large intestine, or colon. The small intestine, a tube of about 4 metres long and 2.5 cm in diameter, can be sub-divided into the upper, mid and lower area which are called the duodenum (about 25 cm long), jejunum (1.5 metres long) and ileum (2.5 metres long) respectively whereas the large intestine is sub-divided into the ascending colon, transverse colon, descending colon, and sigmoid colon. The ileum locates at the lower end of the small intestine and it contains lymphoid tissue that protects the small intestine from the invasion of microorganisms from the large intestine.

The small intestine is the major site of digestion and absorption. The intestine has an extensive internal surface area due to numerous villi, 0.5–1.5

mm high finger-like projections, in the wall and microvilli (roughly  $1.0\ \mu\text{m}$  long and  $0.1\ \mu\text{m}$  in diameter) in the membranes of mucosal cells. Digestion is completed in the small intestine, and water-soluble materials such as simple sugars and amino acids are absorbed into the blood vessels in villi whereas fats are absorbed into the lymph vessels.

The small intestine secretes intestinal juice (succus entericus) spontaneously when acidic or hypotonic chyme enters the duodenum. The juice contains bicarbonate and mucus which neutralise the chyme and prevent the acid and pepsin from damaging the duodenal mucosa. A decrease in the secretion of mucus in the duodenum can result in the exposure of the duodenal tissue to the erosive substances, and because the stimulation of sympathetic nerve activity remarkably reduces the production of mucus, a large proportion of peptic ulcers emerge in this site of the gut. The intestinal juice also contains disaccharidases, peptidases and phosphatase that are secreted by the small intestine itself, bile (containing bile salts, bile pigments, cholesterol, lecithin, bicarbonate and mucus) from the liver, and digestive enzymes (trypsin, chymotrypsin, elastase, carboxypeptidase, amylase, lipase, phospholipase A<sub>2</sub>, cholesterol esterase, DNase and RNase) from the pancreas.

Depending on the constituents of chyme, the time chyme takes to pass through the small intestine may vary from 3 hours to 10 hours. Meanwhile the small intestine mixes chyme with digestive enzymes, absorbs the digested products and moves the unabsorbed remains to the large intestine by means of segmentation, peristalsis and the movements of villi. Besides these actions, the small intestine also absorbs a large amount of fluid that has been secreted by the salivary glands, gastric glands, liver (bile) and pancreas (Figure 1.1).

The large intestine is approximately 1.3 metres long in adults and has a greater diameter than that of the small intestine. It has several functions,

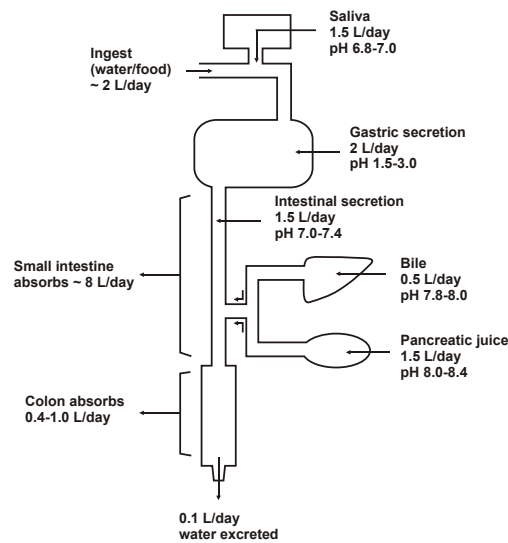

Figure 1.1: The overall secretion and absorption of fluid in the gastrointestinal tract (Modified from Pocock and Richards, 2006).

which include temporary storage of the semi-solid waste (faeces), secreting mucus for lubricating the passage of faeces, and also absorbing most of the remaining fluid and electrolytes. Albeit most water in chyme is absorbed in the small intestine, there still remain a considerable amount of fluid in the chyme that the colon may absorb by osmosis, and failure to do this results in severe diarrhoea (Figure 1.1).

The caecum is a 7 cm-long blind-ended tube which is essential for cellulose digestion in herbivores yet is not functioning in humans. Attached to the caecum is the appendix which has the size of a finger. Again, this has no known function in humans as the caecum. However, appendicitis, the inflammation of the appendix, can be critical as its rupture may cause peritonitis because of the presence of bacteria in the faeces. The colon is about 1.2 metres long and from which most of the residue of digestion would be eliminated within 72 hours, although the remainder of the waste may stay in the colon for a longer term. As faeces are stored in the large

intestine until excretion, and also because the anus is another entry point for organisms, the large intestine is an important reservoir of both microflora and pathogens.

Digestion in the large intestine is largely carried out by the microflora. There exist a large number of bacteria that symbiotically colonise the large intestine. Some bacteria synthesise certain vitamins such as B and K, while some other microflora can ferment indigestible carbohydrates such as cellulose and lipids. Short-chain fatty acids (SCFA) are amongst the by-products of the fermentative metabolism and can be readily absorbed by the colon. Short-chain fatty acid also appears to be an energy source of colonocytes. Microflora in the large intestine also provide protection from gastrointestinal infections by competing with pathogens or commensal microbiota and prevent them from growth or reproduction in the colon (see Section 1.4.2). Gastrointestinal diseases, however, may occur when the microbial ecology is disturbed by the overgrowth of pathogenic organisms or by other factors such as drugs and life style.

## 1.2 Gastrointestinal diseases

The main symptoms of gastrointestinal diseases are alteration in gastrointestinal function, including abdominal pain (*e.g.* heartburn and dyspepsia), nausea and vomiting, indigestion and weight loss, diarrhoea, and gastrointestinal bleeding (Hasler and Owyang, 2005). Heartburn results from gastroesophageal reflux of acid and causes a burning sensation in the oesophagus. Dyspepsia refers to upper abdominal discomfort or pain. Some dyspepsia patients experience ulcer-like symptoms such as epigastric burning or gnawing discomfort (Hasler and Owyang, 2005). Nausea is a subjective feeling of a need to vomit, which is the oral expulsion of the upper gastrointestinal contents. Diarrhoea is a frequent passage of watery stools. Its diagnosis

is broad and its symptoms usually includes infection, inflammation and malabsorption. Some diarrhoea or vomiting cause dehydration that may be lethal if rehydration is not immediately accomplished. Gastrointestinal bleeding may happen in any gut organ. Most upper gastrointestinal bleeding is caused by ulcer disease, gastroduodentis and esophagitis whereas the most prevalent cause of lower gastrointestinal bleeding is haemorrhoid, inflammatory bowel disease or infectious colitis. The taking of non steroid anti-inflammatory drugs (NSAIDs) is also a common cause of gastrointestinal bleeding. Other non-specific symptoms include weight loss, chest pain, fatigue and fever.

Any factors that may cause the digestive system to malfunction are likely to trigger gastroenteritis, and these factors may be divided into biological factors (bacterial, viral and parasite infections) and non-biological factors (drugs, chemicals, toxins secreted by bacteria, improperly prepared food, life styles etc.)

Bacterial gastroenteritis has a high incidence rate worldwide, and will be reviewed in details in the next section (Section 1.3).

Viruses are another common source of the illness that results in acute gastroenteritis. Viral infections among humans include rotavirus , norovirus, sapovirus, astrovirus and adenovirus, rotavirus and norovirus being the prominent cause of viral gastroenteritis (Parashar and Glass, 2005). The infectious dose can be as low as 10–100 viral particles and the virus can be found even in vomit. Although fever, vomiting and diarrhoea can last 1–8 days depending on the causal virus, and no specific antiviral agent is available at this point, treatment is generally not required because the disease is usually self-limited, and oral or intravenous fluid therapy is usually advised if severe dehydration symptom occurs (Parashar and Glass, 2005).



Whichever the cause is, the mechanism of gastrointestinal disease is largely related to host-pathogen interactions (Asakura et al., 2007). In this review only bacterial factors are considered.

## 1.3 Gastrointestinal pathogens

Bacterial gastrointestinal diseases are usually caused by, but not limited to, infection by Gram-negative bacilli *e.g.* *Enterobacteriaceae*, *Campylobacter* spp., *Helicobacter* spp. and related organisms, and *Clostridium* spp.

### 1.3.1 *Salmonella* spp.

The genus *Salmonella* is a Gram negative rod-like facultative anaerobe, and is one of the most common food borne gastrointestinal pathogens. There are three species of *Salmonella* (*S. choleraesuis*, *S. typhi* and *S. enteritidis*) and 1 700 serotypes and the nomenclature is complicated. Of the numerous serotypes, DT104 is the most unusual one in that multiple antibiotic resistance is the common characteristic of the strain (Poppe et al., 1998). The isolation of DT104 has been rapidly increasing since 1990 in Britain (Gresham, 1996) and is now commonly isolated worldwide (Ben Aissa and Al-Gallas, 2008; Ethelberg et al., 2007; Fekete and Nagy, 2008; Kishima et al., 2008; Lee and Lee, 2007; Little et al., 2008; Majtán et al., 2008; Molla et al., 2007; Murphy et al., 2008; Notermans et al., 2005; Valdezate et al., 2007; Wasyl et al., 2006; Weill et al., 2006). The generation of the resistant strain is thought to be due to the increasing use of antibiotics in veterinary practice (Davis et al., 2002).

The symptoms and severity vary widely, but generally *Salmonella* can cause gastrointestinal upset, enteric fever, specific localised infection, nausea,

crampy abdominal pain, diarrhoea and sometimes vomiting (Balows et al., 1991).

### 1.3.2 *Enterobacteriaceae*

*Enterobacteriaceae* includes *Escherichia coli*, *Yersinia* spp., *Enterobacter* spp. and *Shigella* spp.

#### 1.3.2.1 *E. coli*

There are numerous classes of diarrhoeagenic *E. coli* (Clarke, 2001). According to the pathogenic mechanisms, these can be classified into enterotoxigenic *E. coli* (ETEC), enterohaemorrhagic *E. coli* (EHEC), enteropathogenic *E. coli* (EPEC), enteroinvasive *E. coli* (EIEC) and enteroadherent *E. coli* (EAEC). ETEC may colonize the small intestine and produces a heat-labile (LT) and heat-stable (ST) enterotoxin (Qadri et al., 2005). EIEC penetrates and multiplies within the intestinal epithelial cells and may resemble the symptom caused by Shigellae (Blakelock and Beasley, 2003). EPEC causes diarrhoea by adhering to the brush border of the small intestine but does not produce LT or ST (Goosney et al., 2000). EHEC produces several toxins including one that is related to Shiga toxin. *E. coli* O157:H7, having caused several outbreaks, is the most common serotype of EHEC (Manning et al., 2008; Nauschuetz, 1998). EAEC may adhere to HEp-2 cells, but its aetiology is not well known yet (Blakelock and Beasley, 2003). Diarrhoeagenic *E. coli*, particularly ETEC, may cause profuse watery diarrhoea, dehydration, malnutrition, haemorrhagic colitis or haemolytic uraemic syndrome (HUS) (Karmali, 2004).

### 1.3.2.2 *Yersinia* spp.

*Yersinia* spp., especially *Y. enterocolitica*, usually cause diarrhoea and sometimes it may be difficult to distinguish from appendicitis until surgery or ultrasonography is carried out, as it produces pain in the ileocecal area (Balows et al., 1991). Because *Yersinia* can multiply within a wide range of temperature (−1 to 45 °C) (Lake et al., 2004), yersinial enteritis can be caused by oral transmission through raw milk or contaminated pasteurised milk, raw meat or fish. Although rare, the ability to multiply at low temperature has also caused transfusion-associated septicaemia (Roussos et al., 2001; Tipple et al., 1990).

### 1.3.2.3 *Pseudomonas aeruginosa*

*P. aeruginosa* is a Gram-negative aerobe that is a common cause of topical wound infection. Gastrointestinal infection caused by the species has been usually under-estimated (Qarah et al., 2008) but, in fact, it has caused several diarrhoea outbreaks (Falcão et al., 1972; Kienitz, 1979; Porco and Visconte, 1999).

### 1.3.2.4 *Enterobacter* spp.

*Enterobacter* spp. rarely infect healthy bodies but cause diseases in hospitalised persons (Kasper et al., 2005). *E. cloacae* and *E. aerogenes* are the major causes of *Enterobacter* infections, but *Enterobacter sakazakii* (now has been re-classified as a new genus, *Cronobacter*; Iversen et al., 2008) emergence through paediatric nutrition is occasionally reported (Friedmann, 2007; Giovannini et al., 2008).

### 1.3.2.5 *Shigella* spp.

There are three major species of *Shigella* (*S. sonnei*, *S. flexneri*, *Shigella dysenteriae*) and one minor species (*Shigella boydii*) that are relevant to Shigellosis,

in which *S. sonnei* is the species that is responsible for most clinical cases. There are four groups of *Shigella* spp. - group A, B, Q and D - that can be distinguished by biochemical or serological criteria. Group D accounts for most cases of Shigellosis, but all *Shigella* may produce heat-stable and heat-labile enterotoxins, and mortality usually results from severe dehydration (Blakelock and Beasley, 2003). The common symptoms include diarrhoea, dysentery, bloody or mucoid stools, abdominal cramps, tenesmus, ulceration, inflammation and bleeding.

### 1.3.3 *Campylobacter* spp.

The genus *Campylobacter* is a curved or spiral rod-shaped gram-negative organism. This is a widespread zoonotic pathogen and has been recognized as a leading cause of gastroenteritis worldwide. The prevalence of campylobacteriosis has been reported to outnumber that of enteritis caused by other common food-borne pathogens such as *Salmonella* spp. or *E. coli* in several developed and developing countries (Allos, 2001; Meldrum et al., 2006). According to an annual report published by the Institute of Environmental Science and Research (ESR) in 2008, New Zealand has the highest prevalence of campylobacteriosis in the developed world (Institute of Environmental Science and Research, 2008).

*Campylobacter* has an extremely low infectious dose, which may partially explain the high incidence of food borne diseases despite the bacterium being fastidious in respect of nutrition and atmosphere. Robinson (1981) swallowed 500 cells of *Campylobacter jejuni* in 180 ml of pasteurised milk, and the count of the organisms in faeces was examined to be at least  $10^6$  /g within two days. Abdominal cramp and diarrhoea containing mucus also appeared on day 4 and lasted for the next three days in the trial. Wallis

(1994) suggested a similar infective dose which can be as low as 800 cells to initiate infection.

Another possible explanation for the high prevalence regardless of it being fastidious is that the species may either form a protective biofilm on its own, or colonise in biofilms formed by other microorganisms. Bacteria, including *Campylobacter* spp., are known to form biofilms that provide superior protection from lethal or undesirable environment (Buswell et al., 1998; Costerton et al., 1995). *Campylobacter* has been reported to show difference in the potential to form biofilm from strain to strain (Gunther and Chen, 2009). Also, the persistence of *Campylobacter* spp. under environmental stress varies among the types of biofilm formed (Joshua et al., 2006). Although not well demonstrated with *Campylobacter* spp. yet, it is also possible that other bacteria may promote the biofilm formation of the species, as has been seen with other bacteria (Sasahara and Zottola, 1993).

Mostly campylobacteriosis is self-limited, and it can be treated with fluoroquinolones if antimicrobial therapy is necessary. However, deaths have been reported occasionally (Meyer et al., 1997; Peetermans et al., 2000) and its linkage with Guillain-Barré syndrome (Ang et al., 2004) and abortion (Smith, 2002) is also of great concern. Furthermore, although not having been isolated yet in New Zealand (Institute of Environmental Science and Research, 2008), antibiotic-resistant strains have been reported in developed and developing countries (Delsol et al., 2004; Padungton and Kaneene, 2003; Takayama et al., 2005). The increasing rate of resistance to antibiotics is thought to be due to the over-use of antibiotics in veterinary treatment (van Boven et al., 2003).

### 1.3.4 *Helicobacter spp.*

*Helicobacter pylori*, or formerly *Campylobacter pyloridis*, is a Gram-negative microaerobe that predominates in the stomach mucosa. This species was originally reported by Warren and Marshall (1983) and was found to be helical S-shaped. This organism is commonly found in gastric biopsy where most organisms are unlikely to survive due to the acidic gastric juice. Research has shown that *Helicobacter pylori* produces a urease enzyme which metabolises urea into CO<sub>2</sub> and ammonia which neutralises the acidity around the cell so that it is not affected by the gastric acid (Dunn et al., 1997). *H. pylori* induces a strong inflammatory response. Because of this characteristic, *H. pylori* has been implied by the World Health Organization (WHO) as a Group 1 carcinogen of gastric carcinoma (World Health Organization and International Agency for Research on Cancer, 1994) and is now largely known as the major cause of peptic ulcer by the public.

Combinations of amoxicillin, clarithromycin, lansoprazole, metronidazole, tinidazole or bismuth are usually used for *H. pylori* eradication therapy (Dunn et al., 1997; Erah et al., 1997). Nowadays triple therapy (amoxicillin, clarithromycin and lansoprazole or bismuth) is approved by FDA due to its high cure rate (of about 85%) and low relapse rate, albeit diarrhoea and minor side-effects have also been reported (Dunn et al., 1997).

However the treatment of *H. pylori* with antibiotics is increasingly facing complication lately. Some patients revealed symptoms of reactive arthritis (Söderlin et al., 1999) or pseudomembranous colitis that are triggered by *C. difficile* after the *H. pylori* eradication therapy (Kubo et al., 2006; Rai and Rai, 2002; Archimandritis et al., 1998; Nawaz et al., 1998; Teare et al., 1995; Lau et al., 2001; Harsch et al., 2001; Roseveare et al., 1998; Awad et al., 1994).

### 1.3.5 *Clostridium difficile*

*Clostridium difficile* is a commensal, endospore-forming Gram positive anaerobic bacterium that exists in the human intestine.

Despite the recent worldwide outbreaks of *C. difficile* colitis reported (Canada (Eggertson, 2004; Loo et al., 2005; Pindera, 2007), North America (Cookson, 2007), Europe (England (Anonymous, 2005; Katikireddi, 2005; Smith, 2005), Belgium (Joseph et al., 2005), the Netherlands (van Steenberg et al., 2005; Kuijper et al., 2005, 2006) and Northern France (Tachon et al., 2006)) and Japan (Komatsu et al., 2003)), this is actually not a new epidemic enteropathogen. In fact *C. difficile* was first isolated in 1935 by Hall and O'Toole (1935) who termed it "difficile" as it was difficult to cultivate and isolate the species. It has been reported as the agent of antibiotic-associated diarrhoea in humans in 1978 (Bartlett et al., 1978). Until the late 1900s it was considered that antibiotic exposure, advanced age and long hospitalization are the major factor of infection with *C. difficile* (Gerding, 1989; Fekety and Shah, 1993; Kelly et al., 1994).

This organism is found resistant to most antibiotics used nowadays including fluoroquinolones (Bartlett, 2006), primarily because of its endospore, therefore humans that have been staying in hospital for long term are highly likely to be colonised by the organism. With small number of the cells no significant symptom or disease would be caused, but once the normal intestinal flora is disrupted by broad spectrum antibiotic therapy it overgrows in the colon and produces toxin A (TcdA) and toxin B (TcdB). TcdA is an enterotoxin and causes fluid accumulation in the bowel. TcdB, on the other hand, is a cytotoxin and is extremely cytopathic (Poxton et al., 2001; Knoop et al., 1993; Voth and Ballard, 2005).

Interestingly, the outbreaks after 2000 were found to be more frequent, more severe and have higher rates of relapse than those reported in the late

1900s (Bartlett, 2006), and a highly virulent strain, designated BI/NAP<sub>1</sub> or serotype O27 (BI by restriction endonuclease analysis, NAP<sub>1</sub> by pulsed-field gel electrophoresis and O27 by polymerase chain reaction), was found to be responsible for the majority of the outbreaks (Åkerlund et al., 2008). This strain produces substantially more TcdA and TcdB than the usual strains *in vitro* (Bartlett, 2006). It also produces a binary toxin which is an iota-like toxin similar to that produced by *Clostridium perfringens* type E but the role of the binary toxin in the pathogenesis is unknown (Voth and Ballard, 2005).

The disease is almost always restricted to the colon and the symptoms vary in severity, from mild (diarrhoea, fever, decreased gut motility) to extremely severe (fever, pain, toxic megacolon, leukemoid reactions, septic shock, pseudomembranous colitis, hypoalbuminemia, leukocytosis, requirement of colectomy or sometimes death) (Bartlett, 2006).

The emergence of *C. difficile* has potentially complicated the gastrointestinal disease treatment. To control the disease, patient isolation, contact precautions, handwashing with soap and water rather than alcohol-based hygiene and avoidance of the implicated antimicrobial agent(s) are suggested (Bartlett, 2006). If antibiotic treatment is necessary, antimicrobial agents with a low probability of causing *C. difficile*-associated diarrhoea (CDAD) such as tetracycline, narrow-spectrum  $\beta$ -lactams, macrolides, sulfonamides, or if the symptoms are severe, oral vancomycin or metronidazole are recommended (Bartlett, 2006). However, the antibiotic treatment of *C. difficile* had been reported to have a high relapse rate of about 20%. Also metronidazole and vancomycin would cause the overgrowth of vancomycin-resistant enterococci (Al-Nassir et al., 2008) or metronidazole-resistant *C. difficile* strain (Pépin et al., 2005; Musher et al., 2005), therefore an alternative treatment may be urgently required to be developed.



## 1.4 Gastroenteritis treatments

### 1.4.1 *Oral rehydration solution*

Generally, dehydration is the major risk factor for gastroenteritis, and it is recommended to replace lost fluid and electrolytes promptly. WHO recommends a simple oral rehydration solution (ORS) formula, which consists of  $\text{Na}^+$  75 mmol/l,  $\text{K}^+$  20 mmol/l,  $\text{Cl}^-$  65 mmol/l, citrate 10 mmol/l and glucose 75 mmol/l. Glucose assists the absorption of sodium (and therefore water) in the small intestine; potassium and chloride replace the lost ions due to diarrhoea and vomiting, and citrate balances the acidosis due to diarrhoea and dehydration ([World Health Organisation, 2006](#)).

### 1.4.2 *Probiotics*

Although complementary and alternative medicines (CAM) are generally not accepted or regularly used in mainstream medicine ([Kasper et al., 2005](#)), some of them such as probiotics are actually relatively well researched and increasingly used for internal disease control or prevention. Probiotics refer to 'live microorganisms which when administered in adequate amounts confer a health benefit on the host' ([Food and Agriculture Organization and World Health Organization, 2002](#)). These gastrointestinal commensal microflora have been suggested to accomplish beneficial effects to human health by several mechanisms, although some are not well established yet. Some suggested mechanisms include producing trace elements or antimicrobial agents, excluding the pathogenic organisms from colonising the gut by competing for attachment sites or strengthening the barrier function, restoring gastrointestinal barrier function, modulating the immune system

in the host, producing fermentation end products butyrate and propionate that change intestinal pH, facilitating the conversion and uptake of dietary components (vitamins) as well as transforming or excreting toxic substances (bile acids, nitroamines), and generating faecal bulk to reduce the exposure time of the intestinal lumen to the toxic substances. (Louis et al., 2007; Saxelin et al., 2005; Servin, 2004; Sullivan and Nord, 2002, 2005; Surawicz, 2003).

It is estimated that there are trillions of microbial cells with high diversity in the human gut (Ley et al., 2006), most of which are unable to be successfully cultivated *in vitro*, and *Bifidobacterium* spp. and *Lactobacillus* spp. are the most popularly used microorganisms for health promotion. *Bifidobacterium* is an irregular non-sporing Gram-positive anaerobe and was first isolated from human infants' faeces (György, 1953). Pathogenicity is rare among the genus *Bifidobacterium* and only *Bifidobacterium dentium* seems to have pathogenic potential (Hillier and Moncla, 1991). *Lactobacillus* spp. is a regular non-sporing Gram-positive facultative anaerobe and can usually be found in wide range of food such as dairy products, meat, fish, grain, sour dough, fruits, wine and fruits (Sneath and Holt, 1986). Like the genus *Bifidobacterium*, this is a part of normal flora in the mouth, intestinal tract and vagina of humans (Sneath and Holt, 1986). Some beneficial bacteria have been used in the food industry for preventing the growth of spoilage pathogens for centuries, and some bacteriocins such as nisin have also been approved by FDA (Food and Drug Administration, 2001). McAuliffe and Hill (2001) gave a thorough review regarding the properties of bacteriocin.

However, the utility of probiotics in treating gastroenteritis may sometimes be limited. Firstly probiotics may not survive the acidic gastric juice or enzymatic intestinal juice if intaken orally, and consequently the probiotics may have lost their viability to provide any bioactivity in the gastro-intestinal tract. An increasing number of reports also shows that the use of antibiotics

usually eliminates the beneficial bacteria too and the ecological impacts can last for up to 2 years (Bühling et al., 2001; Jernberg et al., 2007; Sullivan et al., 2001; Witte, 2000). Once the microbiological ecology in the gut is disturbed by external factors such as antibiotics, drugs or even stress, some of the organisms may cause a bacterial gastrointestinal disorder which is known as the antibiotic associated diarrhoea (AAD). One significant example of antibiotic associated diarrhoea is *C. difficile* associated diarrhoea that was described above (Section 1.3.5). Some antibiotics are also known to be antagonistic to the action of bacteriocins (for example chloramphenicol is antagonistic to nisin; Brumfitt et al., 2002).

Recent reports also show that probiotics are not free from risk and some clinical studies even suggest that probiotics may be fatal. One of the most significant reports was a well-designed randomised controlled trial (RCT) held in the Netherlands in which Besselink et al. (2008) reported a significantly higher mortality in the probiotics group than the placebo group (24/152 cf. 9/144,  $p = 0.01$ ). In the same report the investigators also noted that there were 9 patients in the probiotics group who suffered bowel ischaemia (8 of which were fatal) whereas there were none in the placebo group. Probiotics septicaemia has also been reported in diabetic patients (Rautio et al., 1999; Zein et al., 2008), short gut syndrome infants (De Groote et al., 2005; Kunz et al., 2004) and a patient with ulcerative colitis (Farina et al., 2001). Numerous examples are also given in a review by Boyle et al. (2006). Interestingly, all reported probiotic bacteraemia occurred only in immunocompromised individuals and sepsis associated with probiotics has not been observed in healthy humans. One possibility is that adherence of probiotics to the intestinal mucosa provokes a higher chance of translocation and virulence in immunocompromised individuals than in healthy ones. That is to say, the use of probiotics on some gastroenteritis patients may adversely lead to or increase gastrointestinal damage.

### 1.4.3 *Antibiotics*

As the symptoms of gastroenteritis are generally self-limited, and also that the disease is also commonly caused by viruses against which antibacterials are of no use, generally administration of antibiotics is neither necessary nor recommended (King et al., 2003). Although in some severe cases antibiotics may be considered for use to shorten the duration of infections (Kasper et al., 2005), numbers of issues on the use of antibiotics, including wasting resources on non-bacterial infection, have arisen during the last few decades.

One of the biggest issues is that the use of antimicrobial agents has been largely associated with development of strains of bacteria resistant to antimicrobial agents. Whilst MRSA and VRE are the resistant bacteria most widely known by the public, there have been countless reports concerning the emerging of the resistant strains of *Salmonella*, *Campylobacter*, *Enterococci*, *E. coli*, *Enterobacter* and other bacteria (Dowell, 2004; Sharma et al., 2005; Thakur and Gebreyes, 2005). This is especially of alarm to hospitalised patients whose immune systems are usually in a weakened state and are susceptible to nosocomial pathogens. The spread of antibiotic-resistant organisms which results in outbreaks of nosocomial infections as well as antibiotic associated diarrhoea has been repeatedly reported and reviewed (Jones, 2001; Komatsu et al., 2003; Loo et al., 2005; McMullin et al., 2005; Pong and Bradley, 2004).

The possible ecological impact of antibiotics therapy on the normal flora in the gut is another concern, because antibiotics can cause disturbances in the ecological balance between the host and microorganisms. Traditionally the study of the ecological composition in faeces as well as on the effect of antimicrobial agents on microorganisms have largely relied on cultivation-based techniques, which are laborious and provide few information on or poor view of the community. The recent advent of several molecular

techniques based on 16S rRNA genes, on the other hand, have made the investigation on the ecological impact of antibiotics on the human gastrointestinal microbiota in detail possible. [Sjölund et al. \(2003\)](#) found that all enterococci isolated from patients who had received *H. pylori* eradication therapy (clarithromycin, metronidazole and omeprazole) showed high-level clarithromycin resistance due to the *erm* (erythromycin resistance methylases) gene which persisted for 3 years after the treatment. [Jernberg et al. \(2007\)](#) also investigated the long-term ecological impacts of clindamycin on *Bacteroides* spp. by detecting the *erm* gene family in the faecal samples of volunteers after 7-day clindamycin administration using rep-PCR (repetitive sequenced based-PCR), real-time PCR and T-RFLP (terminal restriction fragment length polymorphism), and found the antibiotic selective pressure to be persisting for as long as 2 years after the termination of treatment. However the effects of antibiotics on the gut microflora appear to be dependent on several factors including the spectrum of the drugs, microbial taxa, degree of absorption of the drugs, enzymatic/chemical inactivation or interaction between gastrointestinal materials. Indeed, [Dethlefsen et al. \(2008\)](#) reported that some microbial communities recovered to their pretreatment state by four weeks after the end of ciprofloxacin treatment, whereas others failed within six months. It also appeared that many antimicrobial agents may suppress the growth of a part of microorganisms and increase others during therapy (reviewed by [Sullivan et al., 2001](#)). In short, antibiotic therapy can disturb the ecological balance in the gastrointestinal tract, and either the positive or negative effect can remain for months to years.

Another controversial aspect of antibiotic usage to treat gastroenteritis is that, to protect drugs from digestive gastric juice, proton pump inhibitors (PPIs) *e.g.* omeprazole, lansoprazole, pantoprazole, rabeprazole and esomeprazole are usually given along with antibiotics ([Robinson and Horn, 2003](#)). All proton pump inhibitors suppress gastric acid secretion by blocking

the gastric acid pump ( $H^+/K^+$ -ATPase). Although proton pump inhibitors are widely used for the treatment of acid-related disorders *e. g.* peptic ulcers, a few reports pointed out that the acid suppression would inadvertently cause side-effects on the digestive system (Leonard et al., 2007). As reviewed above (Section 1.1.2), gastric acid plays an important defensive role in the digestion system, and therefore suppressing the acid secretion by administering proton pump inhibitors may adversely increase the risk of bacterial invasion in the gut.

To demonstrate the importance of gastric acid secretion, several studies have been conducted to compare the viability of several bacteria in normal and achlorhydric/hypochlorhydric stomachs. Giannella et al. (1972) noted that bacteria in the normal human stomach were promptly killed within 15 min whereas they remained viable in the achlorhydric stomach for longer than 1 hour. Gray and Trueman (1971) reported that patients with gastric surgery had much more severe salmonellosis than those that did not have gastrectomy. Similarly, Hornick et al. (1971) demonstrated that a much higher threshold dose of *Vibrio cholerae* was required to induce diarrhoea in healthy volunteers than the control group that was given sodium bicarbonate to neutralise the gastric acid. In this study the threshold dose differed by 10 000 times. Dial et al. (2004) and Dial et al. (2006) also noted that the use of proton pump inhibitors, which resulted in the lack of gastric acid, may increase the risk of *C. difficile* associated diarrhoea. A meta-analysis done by Leonard et al. (2007) showed that acid suppression associated with the increased risk of enteric infection caused by *C. difficile*, *Salmonella* spp., *Campylobacter* spp. and other microbes. The possibility of association of suppression of acid secretion in the stomach with an increased risk of acute gastroenteritis and community-acquired pneumonia was also suggested (Canani et al., 2006; García Rodríguez et al., 2007). Additionally, Youssef et al.

(2005) reported a rare side-effect, acute pancreatitis, occurring in a patient after being treated with omeprazole to decrease acidity in the stomach.

Given that antibiotic therapy reveals several shortcomings, it is necessary to seek alternative therapy for treatment of gastrointestinal infection.

## 1.5 Honey - a “re-discovered” therapy

This section reviews the use of honey, now considered to be an “alternative medicine” but which has been used since the time of the ancient Egyptian, the Hebrew kingdoms, and historically in China, India, Greece, Rome and many other nations (Crane, 1979). Emphasis in this section is placed on the antibacterial properties of honey.

The use of honey for treating gastroenteritis, peptic ulcers or gastritis can be traced back to the ancient era. The Muslim prophet Mohammed (Al-Bukhari, 1976) and the Roman physician Celsus (Celsus, (c.25 A.D.) 1935) used honey as a cure for diarrhoea. The use of honey on treating gastroenteritis was also recorded in ancient China. Other countries, especially Russia and Arabic countries, also have been traditionally using honey as an elixir for treating upper intestinal dyspepsia (Molan, 1999).

Honey is produced by bees from the nectars they collect from flowers. When a bee collects nectar from flowers, it secretes into it enzymes from its pharyngeal gland. The nectar is then dehydrated and matured in the honey combs as the stored dietary energy source of the bees. Various kinds of honey have been produced in the world and the property of the honey usually reflects that of the floral source. Crane (1979) produced a thorough review on honey in which she noted that the medical literature of honey may be traced back to as far as 2000 BC. Crane (1979) also noted that in England and the Soviet Union honey by itself was used as a surgical dressing for open wounds, burns, and septic infections in the mid-20th century. It is also

of interest to note that a clinical trial in Switzerland revealed that honey was useful for easing the sickness after radiation treatment (Buman, 1953). In the Chinese Encyclopaedia (1727) it is recorded that honey is also used in ancient China for various diseases (Crane, 1979).

### 1.5.1 *Composition and properties of honey*

Honey is a complex material but is primarily a saturated or super-saturated solution of sugars which largely consists of glucose and fructose (84%) and the high percentage of sugars makes it of high osmolarity. Although present in much lesser quantities than glucose and fructose, honey also contains other carbohydrates including disaccharides (sucrose and maltose) and oligosaccharides which seem to vary depending on the floral source of the honey (Molan, 1996).

Besides carbohydrates honey also contains a number of enzymes. Some of the most significant enzymes in honey are glucose oxidase, amylase and invertase, which appear to originate from honeybees (Molan, 1992a). Glucose oxidase has been of particular significance as this is responsible for the generation of gluconic acid and hydrogen peroxide, which are mainly responsible for the antimicrobial activity of honey (see Section 1.5.2). Other minor enzymes including catalase (Dustmann, 1971) and acid phosphatase (White, 1975) are also found in some honeys but these are likely to be derived from the pollens and nectar of plants.

Honey contains other constituents (White, 1975). These include vitamins A, the B group of vitamins, and vitamins C, D, and E, mineral salts, organic acids, proteins, amino acids, lipids, hydroxymethylfurfuraldehyde (HMF) and other minor substances that contribute to honey colour, aroma and flavour, although these are relatively less in significance in the daily diet because of their low concentrations. Interestingly, hydroxymethylfurfuralde-



hyde may be formed by the decomposition of fructose in the presence of acid and this was usually taken as the evidence of the addition of invert sugar. Research showed that even fresh honey contains a small amount of hydroxymethylfurfuraldehyde, which increases with time when the honey is stored at room temperature. The increase in hydroxymethylfurfuraldehyde level is retarded when stored in a cool environment (White et al., 1964).

### **1.5.2 *The antibacterial activity of honey***

Honey has been used in medical treatment as an antiseptic since ancient times until antibiotics were invented. However, the nearly unlimited use of antibiotics has led to the emergence of antibiotic-resistant microorganisms that have made the treatments more difficult than ever, and this has also made humans to seek alternative therapies such as honey to treat the diseases. Numerous research studies have shown that honey is effective against a wide range of microorganisms including MRSA and VRE (Molan, 2008b).

Several mechanisms of antimicrobial activity in honey are discussed below.

#### **1.5.2.1 Osmolarity and water activity**

As described previously, the process by which bees make honey and the high content of sugars make it highly osmotic. Most water molecules in honey interact with the sugars and the proportion of “free water”, described as the water activity ( $a_w$ ), is too low for microorganisms to utilise when honey is not diluted. Generally honey is reported to have  $a_w$  of 0.56–0.62 (Bogdanov et al., 1987; Rüegg and Blanc, 1981; Tysset et al., 1980) while most organisms have a minimum  $a_w$  of 0.9–1.0 (Rizvi, 2005) for growth and can not survive in the lower  $a_w$  environment. To reach the  $a_w$  above which

most microorganisms can survive, a typical honey would need to be diluted down to about 2–12% (based on the reasoning that the concentration is proportional to  $-\log a_w$ ; Scott, 1957). Although a few microorganisms such as osmophilic yeasts can live in honey with an unusually high water content and result in spoilage of the honey, undiluted ripened honeys generally have an  $a_w$  which is too low for any species to survive (see Table 1.1).

Table 1.1: Water activity and growth of microorganisms in food. Source: Adopted from Rizvi (2005).

Range of $a_w$	Microorganisms generally inhibited by lowest $a_w$ in this range
0.20–0.50	No microbial proliferation
0.60–0.65	Osmophilic yeasts ( <i>Saccharomyces rouxii</i> ), a few moulds ( <i>Aspergillus echinulatus</i> , <i>Monoascus bisporus</i> )
0.65–0.75	Xerophilic moulds ( <i>Aspergillus chevalieri</i> , <i>Aspergillus candidus</i> , <i>Sallemia sebi</i> ), <i>Saccharomyces bisporus</i>
0.75–0.80	Most halophilic bacteria, mycotoxigenic aspergilli
0.80–0.87	Most moulds (mycotoxigenic penicillia), <i>Staphylococcus aureus</i> , most <i>Saccharomyces (bailli) spp.</i> , <i>Debaryomyces</i>
0.87–0.91	Many yeasts ( <i>Candida</i> , <i>Torulopsis</i> , <i>Hansenula</i> ), <i>Micrococcus</i>
0.91–0.95	<i>Salmonella</i> , <i>Vibrio parahaemolyticus</i> , <i>Clostridium botulinum</i> , <i>Serratia</i> , <i>Lactobacillus</i> , <i>Pediococcus</i> , some moulds, yeasts, ( <i>Rhodotorula</i> , <i>Pichia</i> )
0.95–1.00	<i>Pseudomonas</i> , <i>Escherichia</i> , <i>Proteus</i> , <i>Shigella</i> , <i>Klebsiella</i> , <i>Bacillus</i> , <i>Clostridium perfringens</i> , some yeasts

However, osmolarity may not be useful from an antimicrobial viewpoint as the sugar component would readily be diluted by body fluid if ingested or by exudate if used as a wound dressing. Also the sugar content in honey can be rapidly absorbed in the gastrointestinal tract. Once honey is diluted, the water activity rises and the osmolarity is no longer inhibitory to the microorganisms.

### 1.5.2.2 Acidity

Honey is characteristically acidic, with an average pH between 3.2 and 4.5 (White, 1975) which is too low for most organisms to survive as the optimal pH for most organisms is between 7.2–7.4 (Sneath and Holt, 1986) and the viability largely declines as the acidity rises. Although several organisms can survive in relatively acidic conditions (*e.g.* *E. coli* at pH 4.3, *P. aeruginosa* at pH 4.4 and *Salmonella* spp. at pH 4.0; Thimann, 1963, the pH of undiluted honey is usually too low for the microorganisms to survive. The acidity of honey is largely due to the gluconic acid that exists in honey as shown in the reaction equation 1.1.

However, like the osmolarity described previously, acidity is unlikely to be a key factor that is responsible for the antimicrobial activity. The quantity of gluconic acid is quite low and the pH would be raised by dilution of honey with body fluid which contains buffers (0.17–1.17%; White, 1975). Research has shown that a buffered gluconolactone/gluconic acid solution that was equivalent to 25% honey solution did not reveal detectable antibacterial activity against *Staphylococcus aureus* in an agar diffusion assay whereas 12.5% honey solution gave much higher activity (Molan and Russell, 1988). Other research studies have shown that a remarkable antibacterial activity can be detected even after honey has been neutralised, which suggests that the level of antimicrobial activity is not linearly correlative to the pH (Molan, 2008b).

### 1.5.2.3 Phytochemical compounds

Several phytochemical compounds have been isolated from honey by many researchers. These include benzyl alcohol, pinocembrin, terpenes, 3,5 - dimethoxy - 4 - hydroxybenzoate (syringic acid), methyl 3,5-dimethoxy-4-hydroxybenzoate (methyl syringate), 3,4,5-trimethoxybenzoic acid, 2-hydroxy-3-phenylpropionate, 2-hydroxybenzoate and 1,4-dihydroxybenzene

(Russell et al., 1990). However, the quantity of these compounds in honey is too low to account for the significant antimicrobial activity.

#### 1.5.2.4 Hydrogen peroxide

Hydrogen peroxide is one of the dominant antibacterial substances that exist in honey. When a bee collects nectar from flower, it secretes glucose oxidase from its hypopharyngeal gland into the nectar to assist the formation of honey from the nectar. Through the activity of this enzyme, glucose in the honey is transformed into gluconic acid and hydrogen peroxide as shown in the reaction equation below (Molan, 1995):

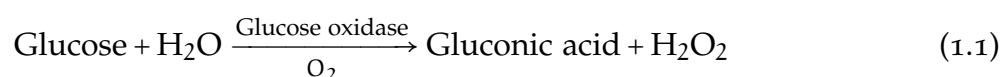

Hydrogen peroxide is an effective antimicrobial against a number of microorganisms, and is commonly used as an antiseptic. It is reported that some microorganisms, mainly *Lactobacillus* spp., produce hydrogen peroxide for help competing against other microorganisms (Chaveerach et al., 2004; Voravuthikunchai et al., 2006).

There are several drawbacks when hydrogen peroxide is used as an antiseptic. First, hydrogen peroxide is readily degraded into oxygen and water when catalase exists. As catalase exists in plasma and in body tissues, which would destroy hydrogen peroxide, the efficacy of the antiseptic may be lost in a short time. Second, hydrogen peroxide is an irritant to body tissues and the patients may feel uncomfortable. Third, reactive oxygen species (ROS) derived can do harm not only to bacterial cells but to tissue by breaking down proteins, nucleic acids and cell membrane lipids, and also by activating proteases in the wound tissues (Ossanna et al., 1986; Peppin and Weiss, 1986; Turner, 1983; Weiss et al., 1985). Therefore using hydrogen peroxide as an antiseptic is unfavourable.

It is interesting to note that undiluted honey has a negligible level of hydrogen peroxide, and even if honey is diluted the concentration of hydrogen peroxide generated is still far lower than the 3% solution of hydrogen peroxide typically used as an antiseptic (Lineaweaver et al., 1985). An explanation to this is that the glucose oxidase in honey is inactive when the honey is undiluted. The enzyme reveals highest activity at pH 6.1 and a good activity between pH 5.5–8, low activity at below pH 5.5 and zero at pH 4 (Schepartz and Subers, 1964). Indeed, Bang et al. (2003) reported that the concentration of hydrogen peroxide in honey increased once it was diluted, and reached a maximum level of 3.65 mM when the honey was diluted down to 50% (v/v), but this was still far lower (242-fold) than in the 3% hydrogen peroxide solution used as an antiseptic. Interestingly yet, it has been found that low levels of hydrogen peroxide is more effective when exposed continuously to bacteria than when applied as a bolus (Pruitt and Reiter, 1985), which suggests that the continuously generated hydrogen peroxide caused by glucose oxidase in honey is in fact more antibacterial than the low concentration could have suggested.

It must be noted that hydrogen peroxide in honey seems to reveal higher antibacterial activity than hydrogen peroxide alone, which suggests that some indigenous substances in honey would raise its activity. Miller (1969) and Roos and Balm (1980) added 0.1 mM ascorbic acid and metal ions in a hydrogen peroxide solution and found that the bactericidal potency of hydrogen peroxide increased. In another study done by Waites et al. (1979) it was shown that hydrogen peroxide was more sporicidal when 10 mM copper was added. McCulloch (1945) also showed that 0.83 mM iron, copper, chromium, cobalt or manganese increased the potency of hydrogen peroxide 10-fold. As the antibacterial action of hydrogen peroxide is largely achieved via oxygen free radicals rather than by hydrogen peroxide itself (Turner, 1983), it is possible that the synergistically enhanced antimicrobial potency

of hydrogen peroxide being reported is due to the catalytic action of the ions that potentialised the production of the damagingly reactive hydroxyl free radical species.

Equation 1.1, however, also suggests that the gastrointestinal environment may be unfavourable to the antibacterial activity in honey that is due to hydrogen peroxide. Oxygen is needed for hydrogen peroxide to be produced by glucose oxidase activity, whereas oxygen is not available in the intestines. Although glucose oxidase is stable against digestion by protease activity in the gut and intestine (Stecher et al., 1968), it may be denatured by the low pH in the stomach (Keilin and Hartree, 1948). That is, it is possible that the actual antibacterial activity of honey in the gut might not be as significant as that observed at the bench (Adebolu, 2005; Al-Waili et al., 2005; Mundo et al., 2004) because hydrogen peroxide production could have been at least impaired (although hydrogen peroxide having been accumulated in diluted honey before it entered the gut could be of some effect).

#### 1.5.2.5 Non-peroxide component

Several researchers have shown that beside hydrogen peroxide there exists non-peroxide antibacterial activity in some honeys. In these studies the authors noticed that some honeys exhibited antibacterial activity even if the honeys were heated to inactivate glucose oxidase (Gonnet and Lavie, 1960; James et al., 1972; Molan and Russell, 1988; Roth et al., 1986) or treated with catalase (Adcock, 1962; Allen et al., 1991a,b; Hodgson, 1989; Molan and Russell, 1988; Roth et al., 1986) to destroy the hydrogen peroxide in the honeys.

Specifically in some manuka honey (*Leptospermum scoparium*) produced in New Zealand there exists a substantial antimicrobial activity that is not destroyed by catalase (Allen et al., 1991a,b). Much research has been done on the non-peroxide antibacterial activity of manuka honey and it has

been found that the activity is more stable than is the antibacterial activity due to hydrogen peroxide (not destroyed by light and heat). It actually increases with time at room temperature (Peter Molan; personal communication). However, it is rapidly inactivated in an alkaline environment. As this unusual non-peroxide activity only exists in manuka honey, Prof. Peter Molan at the University of Waikato termed this activity as the Unique Manuka Factor (UMF). The non-peroxide activity of manuka honey has revealed significant efficacy against wide range of organisms, including the antibiotic-resistant organisms MRSA and VRE that are otherwise difficult to eradicate (Cooper et al., 2002a; Natarajan et al., 2001).

It should be noted that this non-peroxide antibacterial activity exists only in some manuka honey. Several possibilities have been suggested to explain the variation in the activity of manuka honey, and these theories have recently been thoroughly examined by Stephens (2006). After investigating several possible biological factors (animal, plant and fungal associations) and non-biological factors (location of sites and climate), he concluded that some manuka honey had been diluted by nectar collected from other flora species by honeybees. In some manuka honey samples it was estimated by measurement of thixotropy that they contained less than 30% *Leptospermum* nectar, which renders the non-peroxide antibacterial activity too low to be measured in the agar diffusion assay of Allen et al. (1991a).

#### 1.5.2.6 Methylglyoxal in manuka honey

While this project was progressing, Mavric et al. (2008) published the proposal that methylglyoxal (MGO) is the substance responsible for the non-peroxide antibacterial activity of manuka honey. At the same time Adams et al. (2008) used HPLC to isolate the non-peroxide antibacterial activity in manuka honey and proved that it was methylglyoxal.

Surprisingly, [Adams et al. \(2009\)](#) found that methylglyoxal does not dominate in freshly produced manuka honey, nor does it exist in the nectar of manuka flower at a detectable level. [Adams et al.](#) reported that the nectar of manuka flower contained a high level of dihydroxyacetone (DHA), and storage at 37°C led to a decrease in the level of the dihydroxyacetone in the honey and a related increase in that of methylglyoxal. This finding, that the methylglyoxal in manuka honey is formed with time from the dihydroxyacetone in the nectar of manuka flower, is in agreement with the observation that the non-peroxide antibacterial activity of manuka honey continuously increases during storage (Peter Molan; personal communication).

Whilst the finding that methylglyoxal is the major antibacterial factor of manuka honey is of interest, it may be still too early to draw conclusion that methylglyoxal alone is the only factor that is responsible for the significant non-peroxide activity in manuka honey. [Molan \(2008b\)](#) pointed out, using the data published by [Adams et al. \(2008\)](#), that methylglyoxal alone did not account fully for the antimicrobial activity that a manuka honey generally has. To illustrate that methylglyoxal does not fully explain the non-peroxide antimicrobial activity in manuka honey, [Molan \(2008a\)](#) also compared the antimicrobial activity of methylglyoxal in honey with that of methylglyoxal in water, and demonstrated that the antibacterial activity of the former was more than 3–4 times higher than that of the latter. These results clearly explain that methylglyoxal alone does not account for the antimicrobial activity of manuka honey, and also suggest that some non-antimicrobial components that exist in the honey must have acted as synergists with methylglyoxal to provide the substantial antibacterial activity of manuka honey. Additionally, in accordance with the regression analyses amongst the scatter plots of methylglyoxal vs antibacterial activity given by [Adams et al. \(2008\)](#) and [Atrott and Henle \(2009\)](#), there exists non-peroxide antibacterial activity equivalent to that of around 7.5–10% phenol that is not accounted



for by methylglyoxal alone if the linear regression plot is extrapolated back to zero methylglyoxal. As honey has a very complex composition, and also there are various interactions among the components that may influence its activity, further research is needed to be done on the antimicrobial components in manuka honey to understand the mechanism(s) of the honey on microorganisms.

### 1.5.3 *Reported use of honey for treating gastroenteritis*

Honey has been used for the treatment of veterinary diarrhoea. An 8% (v/v) solution of honey was reported to be effective for the treatment of chronic diarrhoea in horses (Linnet, 1996). Kandil et al. (1987) also reported that the number of ulcers caused by aspirin, a non-steroidal anti-inflammatory drug (NSAID), in 10 rats was significantly decreased in the group treated with floral honey (3 cf. 10), whereas it was less significantly decreased if treated with honey from sugar-fed bees (8 cf. 10) or increased in those given saline (15 cf. 10). Ali (1995) carried out a similar study, in which the healing rate of honey against ulcers caused by another non-steroidal anti-inflammatory drug, indomethacin, in the rats was reported to be 70%. The same author also reported that honey prevented ulceration from being caused by indomethacin (Ali et al., 1990). Badawy et al. (2004) reported that mice infected with *E. coli* O157:H7 or *S. typhimurium* had a lower mortality in the group injected with 7 month old Egyptian clover honey than in the control group (*E. coli*: 0% cf. 86.6%; *S. typhimurium*: 40% cf. 93.3%), whereas the reduction in the mortality was less significant in the honey being stored over a long term. However, it must be noted that Badawy et al. did not include oral rehydration solution as a control group in their animal trial, therefore it is not known if the reduction in the mortality is due to the antibacterial activity of honey or the effect of rehydration of the honey.

A clinical trial in humans with a relatively large sample size was reported by Haffejee and Moosa (1985). In this study 169 infants and children admitted into hospital suffering from gastroenteritis were assigned into two groups (in each group there were 18 patients with bacterial diarrhoea). One group was treated with honey whilst the other was treated with the standard oral rehydration therapy (ORT; a 2% solution of glucose and electrolyte). The treatment with honey solution revealed a statistically significant reduction in the duration of bacterial diarrhoea (58 hours cf. 93 hours), and gave no increase in the duration of non-bacterial diarrhoea. In another clinical trial, reported by Salem (1981), 45 patients with dyspepsia were given no treatment other than 30 ml of honey solution before meals three times daily. After the treatment the number of patients passing blood into faeces declined from 37 to 4, the number of patients with dyspepsia from 41 to 8, the number of patients with gastritis or duodenitis from 24 to 15, and the number of patients with duodenal ulcer from 7 to 2.

#### 1.5.4 *Honey and gastrointestinal pathogens*

Comprehensive reviews of the large amount of research carried out on the antimicrobial activity of honey against a large number of microbial species have been published by Molan (1992a), Blair (2009) and Molan (2009). Several *in vitro* research studies have also shown that honey may reveal antimicrobial efficacy against a wide spectrum of gastrointestinal pathogens. The findings from these are summarised in Table 1.2.

However, it must be noted that those reported results are usually not comparable with each other. For instance, Mundo et al. (2004) tested the sensitivity of gastrointestinal pathogens *E. coli* O157:H7, *Listeria monocytogenes*, *S. typhimurium* and *S. aureus* with 13 different honeys including manuka, and reported that a high concentration of honey (50–100%) was

Table 1.2: A review of the published reports on the *in vitro* sensitivity of food-borne gastrointestinal organisms to honey. The concentration of honey shown is the MIC (as % v/v of honey)

References	Organism	Honey type (concentration, %)
Adebolu (2005)	<i>E. coli</i>	2 Nigeria honeys (12.5)
	<i>C. jejuni</i>	2 Nigeria honeys (not inhibitive)
	<i>S. enteritidis</i>	2 Nigeria honeys (50)
	<i>S. dysenteriae</i>	2 Nigeria honeys (50)
Ali et al. (1991)	<i>H. pylori</i>	Natural (20)
Al Somal et al. (1994)	<i>H. pylori</i>	Manuka (5)
Lusby et al. (2005)	<i>E. coli</i>	Rewarewa (5), Medihoney (5), manuka (5), lavender (5), red stungy bark (5), paterson's curse (5)
	<i>S. sonnei</i>	As above
	<i>S. enteritidis</i>	As above

*continued on next page...*

Table 1.2 – Continued

References	Organism	Honey (concentration, %)
	<i>S. typhimurium</i>	As above
	<i>E. aerogenes</i>	As above
Mundo et al. (2004)	<i>Bacillus cereus</i>	Tarweed (100), MT buckwheat (100), manuka (25)
	<i>E. coli</i> O157:H7	Christmas berry (100), saw palmetoo (100), tarweed (100), MT buckwheat (100), manuka (50)
	<i>L. monocytogenes</i>	Melaleuca (100), tarweed (100), MT buckwheat (100)
	<i>S. typhimurium</i>	Manuka (50)
	<i>S. aureus</i>	Cotton (33), christmas berry (100), saw palmetto (50), tarweed (33, 50), MT buckwheat (33, 50), manuka (25, 50), melaleuca (33, 50), horsemint J (100), soybean (100), sunflower (100), rabbit bush (50)
Obi et al. (1994)	<i>E. coli</i>	Nigeria honey(40)

continued on next page...

Table 1.2 – Continued

References	Organism	Honey (concentration, %)
	<i>S. boydii</i>	As above
	<i>Salmonella typhi</i>	As above
	<i>Vibrio cholerae</i>	As above
	<i>Aeromonas hydrophilia</i>	As above
	<i>Plesiomonas shigelloides</i>	As above
	<i>Y. enterocolitica</i>	As above
	<i>C. jejuni</i>	As above
Osato et al. (1999)	<i>H. pylori</i>	Manuka (10), US honeys (15)
Taormina et al.(2001)	<i>E. coli</i> O157:H7	Chinaso buckwheat (25), Montana buckwheat (25), blueberry (25), avocado (25), safflower (25), clover (25)

*continued on next page...*

Table 1.2 – Continued

References	Organism	Honey (concentration, %)
	<i>S. typhimurium</i>	As above
	<i>S. sonnei</i>	As above
	<i>L. monocytogenes</i>	As above
	<i>S. aureus</i>	As above
	<i>B. cereus</i>	As above

required to inhibit all the bacteria. Relatively high concentrations of manuka honey (25–50%) were required to inhibit the bacteria in that study, whereas [Lusby et al. \(2005\)](#) reported that a concentration of 5% of all tested honeys, including manuka honey, were effective against *E. coli*.

There are several factors that have made it difficult to compare the results from the different reports. Some factors that are usually missed out in the reports include the inoculum density and the state of the tested microorganisms, the floral source and the storage of the honey, the media and the method used in the test, and sometimes whether or not an artificial honey is included in the assay as a control. One of the most important parameters being missed out in most of the studies, however, is that the authors failed to standardise the antibacterial activity of the tested honey using a standard antiseptic, so that it is highly possible that the potency of the antibacterial activity of the honeys used in the studies may have varied many fold. This may have led to the different results when testing the same bacterial species even if the honeys were from the same floral source. For example, [Lusby et al. \(2005\)](#) commented that “the overall poor activity of honeys against *S. aureus* was unexpected as previous reports ([Cooper et al., 1999](#)) have shown that manuka honey has an excellent activity against this organism”. The potency of the antimicrobial activity of honey can in fact vary up to 100-fold ([Molan, 1992b](#)). Therefore, it is essential to have the antimicrobial activity in a honey standardised when that honey sample a honey sample is to be assessed against specific microorganisms or to be compared with other types of honey.

Another example of variable results in the published reports is the efficacy of honey against the genus *Campylobacter*, a widespread causative pathogen of diarrhoea. To the author’s knowledge there have been very few reports of testing this genus with honey ([Adebolu, 2005](#); [Obi et al., 1994](#)), and these tests were done on only one isolate of *C. jejuni*. In the

study carried out by [Obi et al. \(1994\)](#), honey was found to have a significant activity against the tested *Campylobacter* whereas [Adebolu \(2005\)](#) reported that natural honeys did not show any antibacterial activity against the tested *C. jejuni* strain, but did not discuss the reason. In fact, the research study done by [Adebolu \(2005\)](#) is highly questionable. Beside the fact that the activity of the tested honeys were not standardised, in this work the agar diffusion method with nutrient media was used, which may not be suitable for testing the sensitivity of slow-growing bacteria like *Campylobacter* spp. against honey, as the honey may have diffused out into the agar and thus had its concentration decreased to a level below the MIC by the time the microorganism had grown. This dilution by the agar means that the MIC values for any antimicrobial agent will be reported as being higher than the true value when an agar diffusion method is used.

Yet another variable that is commonly missed out in studies that are in the literature is the cell density of the bacteria being tested in the susceptibility assay. It is generally observed that the higher the cell number, the more resistant the cells are to antimicrobial agents. Depending on the species of bacteria or the antibacterial agents being tested, the MIC could rise 4 to 16-fold with as little as 0.5 log<sub>10</sub> increase in inoculum density ([Aldridge and Schiro, 1994](#)). [Wiegand and Burak \(2004\)](#) reported that the MIC of eight tested antibiotics against *P. shigelloides* dramatically increased from ≤0.03 mg/l using 10<sup>5</sup> CFU/ml up to 16 mg/l using 10<sup>6</sup> CFU/ml. It has also been observed that the influence of inoculum size substantially increased as the inoculum exceeded 9×10<sup>7</sup> CFU/ml ([Edwards et al., 1991](#)). The influence of inoculum density on sensitivity studies is understandable because an increase in the inoculum would reduce the effective concentration or the per-cell concentration of antibacterial agents ([Udekwu et al., 2009](#)). Therefore, without the information on the cell density being given, it would be difficult



to determine if the reported sensitivity of the microbes to the antibacterial agents being tested is actually over-estimated or under-estimated.

In this thesis both the antibacterial potency and the cell density are standardised, and this makes the findings from this thesis of greater value than those from other similar work where this was not done.

### 1.5.5 *Honey and probiotics*

The gut microflora plays an important role in maintaining gastrointestinal health. It is thought that by maintaining the beneficial microorganisms, humans may decrease the chance of suffering from gastroenteritis.

Several researchers have shown that honey may reveal positive effects on the normal flora, although some of the results may not always agree with others due to several experimental factors such as the floral source of the tested honey and the microbial flora examined. [Ezz El-Arab et al. \(2006\)](#) demonstrated that the colon bifidobacteria and lactobacilli counts in male Swiss albino mice were markedly increased in the group receiving food supplemented with a monofloral (cotton) honey even when the mice had administered ochratoxin A (10 ng/kg by weight/day) or aflatoxins (1 µg/kg by weight/day), although the concentration of the honey in the diet was not clearly noted. [Kajiwara et al. \(2002\)](#) compared the stimulative effect of 5% honey on the growth of intestinal bifidobacteria with fructooligosaccharide (FOS), galactooligosaccharide (GOS) and inulin, and found them to be equivalently effective. [Shamala et al. \(2000\)](#) also noted that *Lactobacillus acidophilus* and *L. plantarum* had higher viable counts in a medium with a diluted honey (equivalent to 1% sugar concentration; floral source unknown) than in a medium with sucrose (1%) or a mixture of glucose (0.5%) and lactose (0.5%). An *in vivo* study conducted by the same authors also showed that viable counts of lactic acid bacteria from both small and large intestines

of rats fed with honey were markedly higher than those from rats fed with sucrose (Shamala et al., 2000).

On the other hand, Varga (2006) reported that none of the 1%, 3% and 5% (w/v) acacia honeys added in yogurt had stimulatory or inhibitory effect on *Streptococcus thermophilus* and *Lactobacillus delbrueckii* subsp. *bulgaricus* in the yogurt. This was partly in agreement with a report by Chick et al. (2001) in which *L. acidophilus* and *Bifidobacterium bifidum* in addition to the same species (*S. thermophilus* and *L. delbrueckii* subsp. *bulgaricus*) were neither positively nor negatively affected by 5% (w/w) clover honey added in skim milk in comparison with other sweeteners, although the production of lactic acid by bifidobacteria appeared to be significantly enhanced by the honey. However, so far there is no report showing that honey is detrimental to the normal flora, perhaps due in part to the antibacterial activity of the reported honey not being as significant as that of manuka honey.

The antibacterial activity of manuka honey against gastrointestinal organisms has been studied (Molan, 2009; Al Somal et al., 1994; Mundo et al., 2004), however all these reports only considered the efficacy of the honey against one or more specific enteropathogenic species but did not take the possible impact of the antibacterial activity of manuka honey on the normal flora into account. Since manuka honey revealed a significant antimicrobial activity against a wide range of microorganisms, it is also possible that the honey may be inhibitive to the probiotic gastrointestinal microflora.

## 1.5.6 *Possible mechanisms that may be involved in the treatment of gastroenteritis with honey*

### 1.5.6.1 Rehydrating electrolytes

Oral rehydration therapy, with a solution of glucose and electrolytes, is recommended when acute gastroenteritis occurs because the gastrointestinal tract re-absorbs large amount of fluid daily to maintain the balance of electrolytes in the body (Figure 1.1), and spontaneous dehydration due to vomiting or diarrhoea can be more critical or fatal than infection itself (World Health Organisation, 1976). In this aspect, honey can be useful because it consists of sugars and also contains ions. Additionally, although an electrolyte solution with glucose added (ORS) is recommended by the World Health Organisation (2006), in the clinical trial approached by Haffejee and Moosa (1985) an ORS in which glucose was replaced with honey (the glucose concentration and electrolyte content being identical to those in the ORS by WHO) seemed to be more effective than glucose-electrolyte solution in re-hydrating patients. Fordtran (1975) suggested that fructose may also promote the uptake of potassium, which is an extra advantage when treating gastrointestinal disorders with honey.

### 1.5.6.2 Repairing damaged mucosa

The second possible mechanism for honey to alleviate gastroenteritis is through repairing the damaged gastrointestinal mucosa, which may be involved simultaneously with the anti-oxidative and anti-inflammatory activity.

Inflammation and oxygen-derived free radicals have been thought to be involved in gastroenteritis (Asakura et al., 2007), and honey has been reported to contain a number of anti-inflammatory and antioxidant compo-

nents (Al-Waili, 2003; Aysan et al., 2002; Bilsel et al., 2002; Duddukuri et al., 1997; Nasuti et al., 2006. Also reviewed in Molan, 2001). These activities are largely relevant to the topical treatment of wounds with honey (White et al., 2006), and both these activities may also apply to the gastrointestinal ulcers. Mahgoub et al. (2002) reported in an animal trial that honey (5 g/kg) provided almost 100% protective effect on Wistar albino rats from acetic acid-induced colitis, whereas a mixture of glucose, fructose, sucrose and maltose did not provide any protection. The same research group also tested several biochemical properties and found that honey prevented depletion of the antioxidant enzymes, reduced glutathione and catalase. Bilsel et al. (2002) also investigated the effect of honey on induced colonic inflammation in rats and found that with honey there was a significantly lower percentage in mucosal damage than with prednisolone, a drug commonly used to treat inflammatory bowel disease ( $P=0.04$ ).

### 1.5.6.3 Prebiotic effect of honey

Honey also appears to have a prebiotic effect, which improves the growth of microflora that directly and/or indirectly help retard enteropathogenic infections. Ustunol and Gandhi (2001) reported that the growth of *Bifidobacterium* spp. were significantly improved in 3–5% (w/v) honey solution. Kajiwara et al. (2002) demonstrated similar results and also observed that the mean doubling times decreased from 147–690 hours to 9.9–14.3 hours. Whilst Astwood et al. (1998) and Sanz et al. (2005) demonstrated that some honeys contained oligosaccharides, it is interesting to note that the effects of honey stimulating the growth of microflora presented in Kajiwara et al. (2002) and Ustunol and Gandhi (2001) were higher than those of fructooligosaccharide, galactooligosaccharide and inulin.

#### 1.5.6.4 Antimicrobial actions

The indigenous antimicrobial properties in honey stated above may inhibit the growth of enterobacteria. As demonstrated in the study of Haffejee and Moosa (1985) in which the duration of the bacterial diarrhoea was halved whereas the viral diarrhoea was not, it is possible that the effectiveness of honey on treating diarrhoea is partially contributed by the antibacterial activity, although this may also suggest that the antiviral activity in the honey was also partially contributing to this, as otherwise the duration of the viral diarrhoea in this trial could have increased as antibacterial agents commonly do. Indeed, *in vitro* studies have shown that several honeys exhibit significant inhibition on gastrointestinal pathogens including *Bacteroides*, *E. coli*, *H. pylori* or *Salmonella* (Adebolu, 2005; Ali et al., 1991; Al Somal et al., 1994; Al-Waili et al., 2005; Mundo et al., 2004; Obi et al., 1994; Osato et al., 1999; Shin and Ustunol, 2005; Taormina et al., 2001). Interestingly, the microbiological action may also be due to the prevention of organisms from adhering to gastrointestinal epithelial cells (Alnaqdy et al., 2005; Breton and Pineau, 1999; George et al., 1978b; Lerrer et al., 2007).

## 1.6 Intention of this research project

It must be noted that the study in this thesis does not intend to investigate all possible factors that may exist in the gastrointestinal environment as this would not be feasible. The aim of this study was primarily to evaluate the antimicrobial effect of manuka honey on enterobacteria with regard to several gastrointestinal factors that may potentially affect the efficacy of the honey against the organisms. These factors include the less aerobic atmosphere, the time required for the honey to inhibit the growth of enter-

obacteria, the declining honey concentration to which the enterobacteria may be exposed, and the acidity and digestive enzymes in the gut.

The aims of each chapter in this thesis are as follow:

- To evaluate a cost-effective cultivation method for studying gastrointestinal bacteria in a microaerobic environment. (Chapter 3)
- To investigate the efficacy of manuka honey against common gastrointestinal pathogens and probiotics dominant in the gastrointestinal environment. (Chapter 4)
- To investigate the effect of oxygen on the production of peroxide activity thereby the total antimicrobial activity of honey. (Chapter 5)
- To obtain information on the kinetics of the antibacterial effect of manuka honey by measuring the “time to kill” and the postantibiotic effect (PAE). (Chapter 6)
- To find the effect that the digestive enzymes would have on the activity of the honey. (Chapter 7)

## GENERAL MATERIALS AND METHODS

---

This chapter describes the general materials and methods routinely used in this study. Bacterial cultures and microbiological media used are listed, and the reasons the particular media were used are explained. Methods modified for specific situations are given in the relevant chapters.

## 2.1 Culture media

### 2.1.1 *Trypticase soy broth (TSB)*

Trypticase soy broth (TSB; BD Bacto Cat. No. 211825) was used for culturing the test organism *S. aureus* ATCC 9144 one day before the honey antibacterial activity test.

TSB was made up 30 g of powder to 1 l of purified water. This was then dispensed as 10 ml aliquots in universal bottles, autoclaved at 121°C for 15 min and kept at room temperature until used.

### 2.1.2 *Nutrient agar (NA)*

Nutrient agar (NA; BD Difco Cat. No. 213000) was used for preparing *S. aureus* ATCC 9144 seeded agar plates which were used for testing the antibacterial activity of honey samples (See Section 2.5).

NA was made up 3.45 g of powder to 150 ml of purified water in a 250 ml flask. This was then stopped with a cotton plug and autoclaved at 121°C for 15 min and kept at room temperature until used.

### 2.1.3 *Mueller-Hinton broth (MHB)*

Mueller-Hinton broth (MHB; Difco Becton Dickinson Cat. No. 275730) is a medium commonly used for antimicrobial susceptibility testing of organisms (National Committee for Clinical Laboratory Standards, 2000) because it supports the growth of most non-fastidious organisms. It also has a low thymine and thymidine content and is totally devoid of sulfonamide an-



tagonists. Although it is less likely that these contents would influence the activity of honey, the internationally accepted medium was used for general cultivation of most non-fastidious organisms and also for the broth dilution assay in this study.

MHB was made up 21 g of powder to 1 l of purified water. This was then dispensed as 10 ml aliquots in universal bottles, autoclaved at 121°C for 15 min and stored at room temperature until used. The MHB for cultivating fastidious *Campylobacter* spp. and *H. pylori* (see Section 2.2) was stored in a dark refrigerator.

#### **2.1.4 Reinforced clostridial medium (RCM)**

Reinforced clostridial medium (RCM; MERCK Cat. No. 1.05411.0500) was used for cultivating anaerobes such as *C. difficile*, *Propionibacterium acnes*, *B. animalis* subsp. *lactis* and *Lactobacillus* spp.

To make RCM, 33 g of powder was dissolved in 1 l of purified water, dispensed in universal bottles as 10 ml aliquots, autoclaved at 121°C for 15 min and then made air-tight. If not used right after this, the sterilised RCM was stored in a dark refrigerator and, before use, this was boiled for 10 min and cooled in chilled water to remove any oxygen dissolved in the broth.

#### **2.1.5 Cooked meat broth**

Cooked meat broth was used for transporting or storing anaerobes (*Clostridium* spp. and *P. acnes*).

To make cooked meat broth, 1 g of cooked meat granules (LAB M Cat. No. LAB24) was added into 13.3 ml purified water, sterilised at 121°C

for 15 min, then the lid was air-tight and the broth was stored in a dark refrigerator.

### **2.1.6 *de Man Rogosa and Sharpe medium (MRS)***

de Man Rogosa and Sharpe medium (MRS; MERCK Cat. No. 1.05463.0500) agar and broth were used in the cultivation and enumeration of *B. animalis* subsp. *lactis* and *Lactobacillus* spp.

MRS agar was made by adding powder upto 1 l purified water at the rate of 66.2 g/l. MRS broth was made at the rate of 52.2 g/l. These were then autoclaved at 121°C for 15 min and stored at room temperature.

### **2.1.7 *Brain heart infusion yeast extract medium (BHIYE)***

BHIYE broth (Moore and Madden, 2000) is an enriched medium used for cultivating fastidious organisms (*Campylobacter* spp. and *H. pylori*).

To make the medium, 37 g of brain heart infusion broth powder (BHI; BD Bacto Cat No. 237500) and 6 g of yeast extract (YE; Sharlau Cat. No. 07-079) were made up to 1 l of purified water. This was then dispensed as 10 ml aliquots in universal bottles, autoclaved at 121°C for 15 min and stored in a dark refrigerator if not used immediately. After storage, BHIYE was boiled for 10 min then chilled in cold water to remove dissolved oxygen in the broth before use.

### **2.1.8 *Columbia horse blood Helicobacter pylori agar (CHBHP)***

CHBHP (Hasegawa et al., 2002) is an enriched agar consisting of Columbia blood agar base and supplemented with defibrinated horse blood, van-

comycin, trimethoprim, amphotericin B and polymyxin B. Hasegawa et al. (2002) originally developed this medium for cultivating *H. pylori* but in this study Columbia horse blood agar without antibiotics was also used for cultivating *Campylobacter* spp.

To make CHBHP, 22 g of Columbia blood agar base powder (BD Difco Cat No. 279240) was made up to 500 ml with purified water, autoclaved at 121°C for 15 min, cooled in a 45°C water bath for 30 min then aseptically supplemented with 10% (v/v) defibrinated horse blood, vancomycin (10 mg/l), trimethoprim (5 mg/l), amphotericin B (5 mg/l) and polymyxin B (2 500 U/l) and then poured into Petri dishes. As for the CHBHP agar for cultivating *Campylobacter*, the agar surface was dried in an incubator at 37°C for 30 min. The agar plates were stored in a dark refrigerator until used.

### **2.1.9 *Haemophilus medium base agar (HMB)***

*Haemophilus* medium base agar (HMB; Oxoid Cat. No. CM0898) was used for making chocolate agar plates for cultivating *Haemophilus influenzae* in the gas generating systems comparison test in Chapter 3.

HMB chocolate agar was made by dissolving 21 g of powder up to 1 l of purified water, autoclaving at 121°C for 15 min and then cooling in a 45°C water bath for 30 min. The cooled agar was then aseptically supplemented with 10% (v/v) defibrinated horse blood, heated to 56°C until the medium became brown or chocolate in colour, then poured into Petri dishes.

### **2.1.10 *Enriching with defibrinated sheep/horse blood and heat-inactivated horse serum***

Defibrinated sheep blood (GIBCO Invitrogen Cat. No. BL204BSL) was aseptically added (5%, v/v) into melted agar for enriching the medium and also for demonstrating the haemolytic properties of some microorganisms.

Defibrinated horse blood (GIBCO Invitrogen Cat. No. BL104BSL) was used when preparing chocolate agar plates and blood agar plates with Columbia agar or HMB agar for cultivating fastidious organisms (*Campylobacter* spp. and *H. pylori*). The horse blood was added at a rate of 10% (v/v).

Heat-inactivated horse serum (GIBCO Invitrogen Cat. No. 16050-130) was used to enrich BHIYE broth for cultivating the fastidious organisms *Campylobacter* spp. and *H. pylori*. The serum was dispensed as 10 ml aliquots in sterilised universal bottles and then stored in  $-20^{\circ}\text{C}$ . When used the serum was added into broth at a rate of 5% (v/v).

### **2.1.11 *Campylobacter blood-free selective agar***

This blood-free selective agar was used for isolating *Campylobacter* spp. This selective agar contains charcoal as a protectant, and sodium pyruvate and ferrous sulfate as reductants, and amphotericin and cefoperazone as selective antibiotics.

To make the *Campylobacter* selective agar, 22.75 g of powder (LAB M Cat. No. LAB 112) was dispersed in 500 ml of purified water, sterilised by autoclaving for 15 min at  $121^{\circ}\text{C}$  and cooled in a  $50^{\circ}\text{C}$  water bath for 30 min. Selective antibiotics were re-hydrated by reconstituting 1 vial of selective supplement (16 mg cefoperazone and 5 mg amphotericin per vial; Lab M

Cat. No. X112) with 5 ml of sterile water and aseptically added to the cooled agar. This gives the final concentration of 32 mg/l cefoperazone and 10 mg/l amphotericin. After mixing well, the supplemented agar was poured into Petri dishes. After the agar had set, the agar surface was dried in an incubator at 37°C for 30 min. The agar plates were then stored in a dark refrigerator until used.

#### **2.1.12 *Ferrous sulfate-sodium metabisulfite-sodium pyruvate (FBP) supplement***

FBP supplement at the rate of 0.025% has been reported to improve the aerotolerance of *Campylobacter* spp. (George et al., 1978a; Gorman and Adley, 2004). To make the FBP supplement stock solution, 6.25 g of ferrous sulfate, 6.25 g sodium metabisulfite and 6.25 g sodium pyruvate were made up to 100 ml in purified water and then filter-sterilised with a 0.22 µm filter membrane. The filtrant was dispensed as 4 ml aliquots in sterilised bijou bottles and stored in -20°C for no longer than 1 month (Hunt et al., 2001). When used, one bijou bottle of FBP stock was thawed and added into 1 l of broth or agar aseptically just before pouring the agar into Petri dishes.

As sodium metabisulfite in the supplement is inhibitory to *H. pylori* (Goodwin et al., 1985), 6.25% FP (6.25 g ferrous sulfate and 6.25 g sodium pyruvate per 100 ml) instead of FBP was used as an enrichment supplement for cultivating *H. pylori* in BHIYE broth (Jiang and Doyle, 2000).

#### **2.1.13 *Modified Christensen's urea test broth***

The urea broth was used for the rapid urease test (RUT) on *H. pylori* (McNulty et al., 1989). As *Helicobacter* produces a large amount of urease which

degenerates urea into carbon dioxide and ammonia which subsequently generates an alkaline environment surrounding the cell, a urea broth containing phenol red as an acidity indicator is useful for quick identification of the species in cultures. The urea broth contains urea (20 g/l), phenol red (0.04 g/l),  $\text{KH}_2\text{PO}_4$  (2 g/l) and NaCl (5 g/l) in water.

A single colony from a *H. pylori* agar plate was transferred into 100  $\mu\text{l}$  of the modified Christensen's urea test broth and incubated for 30 min at room temperature. The culture was recognised as *H. pylori* if the colony and the broth turned red.

## 2.2 Bacterial cultures

The organisms used in this study are listed in Table 2.1.

All reference strains were obtained from ESR, New Zealand. Most of them were supplied as freeze-dried culture, except that *H. pylori* ATCC 43504 was supplied as slope culture. Most reference strains were revived by aseptically adding about 0.5 ml of broth recommended by ESR into the freeze-dried culture ampoule using a sterile Pasteur pipette, mixing carefully and transforming the rehydrated suspension to suitable solid or broth medium. Rehydration broth used were: MHB for most facultative anaerobes; cooked meat broth for anaerobes, MRS broth for *Lactobacillus* spp.; BHIYE for *Campylobacter* spp. *C. difficile* and *P. acnes* were then stored in the cooked meat broth in a dark refrigerator. Other species were incubated at 37°C in appropriate conditions recommended by ESR. These were then subcultured on appropriate agar plates and incubated (facultative anaerobes on sheep blood agar for 1 day, *Lactobacillus* spp. on MRS agar for 2 days, *Campylobacter* spp. on Columbia horse blood agar for 2 days). The colonies on the agar plates after incubation were then collected on Protect Bacterial Preservers Beads (Technical Service Consultants Ltd.) except that *Campylobacter* spp.

Table 2.1: The bacterial cultures used in this study.

Organism	Source
<i>B. animalis</i> subsp. <i>lactis</i>	NZ dairy food industry
<i>Campylobacter</i> spp. clinical isolates	Medlab
<i>C. coli</i> ATCC 33559	ESR
<i>C. jejuni</i> ATCC 33560	ESR
<i>C. fetus</i> ATCC 27374	ESR
<i>C. difficile</i> ATCC 9689	ESR
<i>C. difficile</i> ATCC 43593	ESR
<i>C. difficile</i> NCTC 11382	ESR
<i>C. difficile</i> clinical isolates	Pathlab
<i>E. aerogenes</i> clinical isolate	Waikato Hospital
<i>E. cloacae</i> clinical isolate	Waikato Hospital
<i>E. faecium</i> ATCC 19434	ESR
<i>E. faecalis</i> ATCC 19433	ESR
<i>E. coli</i> ATCC 25922	ESR
<i>H. pylori</i> ATCC 43504	ESR
<i>L. plantarum</i> ATCC 8014	ESR
<i>L. rhamnosus</i> ATCC 7469	ESR
<i>P. acnes</i> NCTC 737	ESR
<i>P. aeruginosa</i> clinical isolate	Waikato Hospital
<i>S. enteritidis</i> clinical isolate	Medlab
<i>S. typhimurium</i> phage type 104 ("DT104")	ESR
<i>S. flexneri</i> clinical isolate	Waikato Hospital
<i>S. sonnei</i> clinical isolate	Waikato Hospital
<i>S. aureus</i> ATCC 9144	ESR
<i>Y. enterocolitica</i> clinical isolate	Waikato Hospital

were collected in defibrinated horse blood. These recovered cultures were then stored at  $-70^{\circ}\text{C}$ .

*H. pylori* ATCC 43504 was recovered by subculturing on Columbia horse blood chocolate agar plates and incubating at  $37^{\circ}\text{C}$  microaerobically for 3 days. The microaerobic condition was constructed with a spirits burn method described in Chapter 3. The recovered *H. pylori* was then re-suspended in 1.5 ml of defibrinated horse blood (Stanley and Moore, 2000) in small vials and stored at  $-70^{\circ}\text{C}$ .

*S. aureus* ATCC 25923 was used for testing the antibacterial activity of the honey samples.

Most of the clinical isolates of facultative anaerobes used in this study had been isolated from Waikato Hospital patients before this study commenced and were stored in a  $-70^{\circ}\text{C}$  freezer at Waikato University on Protect Bacterial Preservers Beads. The isolates were identified in the Microbiology Department at Waikato Hospital using a range of morphological and biochemical techniques and the Vitek automated bacterial identification instrument (McDonnell Douglas Health System Company). Before use in this study, the isolates were subcultured on sheep blood agar plates, incubated overnight at  $37^{\circ}\text{C}$  and examined for purity.

Three clinical isolates of *C. difficile* were obtained from Murray Robinson, Pathlab Bay of Plenty, New Zealand. These were stored in cooked meat broth when transporting from Pathlab to the Honey Research Unit and were then stored in a dark refrigerator in the laboratory.

Clinical isolates of *Campylobacter* spp. (27), *S. enteritidis* (1) and *Y. enterocolitica* (1) were provided by Chris Picket, Medlab, Hamilton, NZ and were stored in fastidious anaerobe transport swabs (Copan Italia S.P.A.) when transporting them from Medlab to the Honey Research Unit. Clinical isolates of facultative anaerobes were streaked on sheep blood agar plates and cultured overnight at  $37^{\circ}\text{C}$  and the recovered cultures were collected



onto Protect Preservers Beads and stored at  $-70^{\circ}\text{C}$ . *Campylobacter* spp. isolates were streaked on blood-free *Campylobacter* selective agar plates and cultured at  $37^{\circ}\text{C}$  microaerobically for 2 days. The recovered cultures were rubbed off the agar with a sterile cotton swab and transferred into 10 ml BHIYE-FBP broth, then were incubated overnight microaerobically. The enriched *Campylobacter* cultures were collected by centrifuging (12 000 rpm, 15 min) and re-suspended in 1.5 ml of BHIYE-FBP containing 10% glycerol as a cryopreservative agent, in small vials, and stored at  $-70^{\circ}\text{C}$ .

As Medlab differentiates *Campylobacter* spp. isolates only to genus level, extra identification work to species level was needed for investigating the effect of manuka honey on different species of *Campylobacter*. To approach this, the multiplex polymerase chain reaction was used in this work (Section 2.4).

The culture media used for the work in the susceptibility test are shown in Table 2.2. For most facultative anaerobes (*E. coli*, *S. typhimurium* DT104, *S. enteritidis*, *E. aerogenes*, *E. cloacae*, *S. flexneri*, *S. sonnei* and *Y. enterocolitica*) MHB was used in the susceptibility test as suggested by NCCLS (National Committee for Clinical Laboratory Standards, 2002). RCM was used for cultivating and enumerating anaerobes *C. difficile* because the semi-solid medium would protect the anaerobes from oxygen. MRS broth was used for handling *B. animalis* subsp. *lactis* and *Lactobacillus* spp.

The choice of the medium for microaerobes (*Campylobacter* and *H. pylori*), however, was problematic. *Campylobacter* spp. and *H. pylori* are widely known as fastidious pathogens and require strict control of growth conditions. NCCLS has suggested an outline for investigating the susceptibility of these species to antibiotics, nonetheless there still does not exist a “gold standard” protocol for studying these two genera (Silley, 2003). For instance, the agar dilution method using Mueller-Hinton agar supplemented with 5% defibrinated sheep blood is recommended in the outline, where the blood

Table 2.2: Bacterial strains and culture media used in the susceptibility test. MHB: Mueller-Hinton broth. RCM: Reinforced clostridial medium. BHIYE: Brain heart infusion yeast extract broth. MRS: deMan, Rogosa and Sharpe medium. CHBHP: Columbia horse blood *H. pylori* medium. BFCSA: Blood free *Campylobacter* selective agar.

Media	Microorganisms
MHB	Aerobes / facultative anaerobes ( <i>P. aeruginosa</i> , <i>S. aureus</i> , <i>E. coli</i> , <i>Salmonella</i> , <i>Shigella</i> , <i>Enterobacter</i> , <i>Yersinia</i> ), microaerobes ( <i>Campylobacter</i> , <i>H. pylori</i> )
RCM	Anaerobes ( <i>C. difficile</i> )
MRS	Anaerobes ( <i>B. animalis</i> subsp. <i>lactis</i> , <i>Lactobacillus</i> )
BHIYE	Microaerobes ( <i>Campylobacter</i> , <i>H. pylori</i> )
CHBHP	Microaerobes ( <i>Campylobacter</i> , <i>H. pylori</i> )
BFCSA	<i>Campylobacter</i>

is for protecting *Campylobacter* spp. from the damage by oxygen-derived components such as free radicals and hydrogen peroxide (Bolton et al., 1984; Corry et al., 1995). However, it is not suitable for a study with honey because the antibacterial activity of honey is largely or partially due to hydrogen peroxide (Allen et al., 1991a; Molan, 1992a) which would be inactivated by catalase present in the sheep blood. Therefore, whenever possible, using the blood or any substance with catalytic capacity should be avoided when evaluating the antibacterial activity in honey. As an alternative, MHB freshly made right before doing the *Campylobacter* and *H. pylori* susceptibility tests was used in this study.

### 2.3 Honey samples

Manuka honey was obtained from SummerGlow<sup>®</sup> Apiaries. This was given a sample ID number M115 in our laboratory. The total and non-peroxide antibacterial activities of the honey sample were assayed with an agar-well diffusion method, as described in Section 2.5.

To distinguish the antimicrobial effect of honey from any osmotic effects, an artificial honey, which is a sugar syrup simulating the sugar composition of honey, 30.5% glucose, 37.5% fructose and 1.5% sucrose dissolved in purified water (Shannon et al., 1979), was included in this study as a control.

To minimise any change in the antibacterial property of honey samples, both manuka honey and artificial honey were stored in a dark refrigerator until used.

## 2.4 Multiplex PCR

Multiplex PCR was used to identify the *Campylobacter* clinical isolates from Medlab (Wang et al., 2002).

*Campylobacter* DNA was extracted by boiling. A loopful of colony for each isolates was taken from its culture plates, re-suspended in 100 µl of purified water in an Eppendorf tube, heated in a boiling water bath for 10 min and chilled on ice for another 10 min, followed by addition of 100 µl of chloroform and brief centrifuging. The supernatant was to be used as the DNA template, and this was stored at -20°C until the PCR test was carried out.

Each PCR mix (20 µl) consisted of 6 µl of DNA templates, 2.4 µl of 20 µM primers mix (Sigma Inc.), 8 µl of HotMasterMix (2.5×) (Eppendorf Inc. Cat. No. 0032 002.714) and 3.6 µl of MilliQ water. The primer pairs used in this work are shown in Table 2.3. Primer pairs for *C. jejuni*, *Campylobacter coli* and *Campylobacter fetus* were chosen because campylobacteriosis is reported to be usually caused by, but not limited to, these species (Nachamkin and Blaser, 2000).

DNA amplification was carried out in a PTC-100 thermocycler (MJ Research Inc.) and the cycling conditions used were 94°C for 2 min followed by 30 cycles of amplification (95°C denaturation for 30 s, 59°C annealing for

Table 2.3: Oligonucleotide primers and their amplicon sizes used in this study. Source: Wang et al. (2002)

Species	Target gene	Sequence (5'-3')	GeneBank accession no.	Amplicon size (bp)
<i>C. jejuni</i>	<i>C. jejuni hipO</i>	Fwd: ACTTCTTTATTGCTTGCTGC Rev: GCCACAACAAGTAAAGAAGC	Z36940	323
<i>C. coli</i>	<i>C. coli glyA</i>	Fwd: GTAAAACCAAAGCTTATCGTG Rev: TCCAGCAATGTGTGCAATG	AF136494	126
<i>C. fetus</i>	<i>C. fetus sapB2</i>	Fwd: GCAAATATAAATGTAAGCGGAGAG Rev: TGCAGCGGCCCCACCTAT	AF048699	435

20 s and 68°C extension for 40 s) then 68°C for 6 min of final extension. The amplified products were electrophoresed in 1.5% agarose gel (Sigma, Cat. No. A6013) in sodium boric acid (SB) buffer (Brody and Kern, 2004) and analysed with the ScionImage system.

According to the multiplex PCR, of the 27 *Campylobacter* clinical isolates collected from Medlab, 20 were identified as *C. jejuni*, the rest as *C. coli*. No *C. fetus* was found in the clinical isolates.

## 2.5 Honey activity identification

The honey samples used in this work had the strength of their antibacterial activity assayed with the agar diffusion method described by Allen et al. (1991a) which compares the activity of honey with that of a standard antiseptic phenol.

### 2.5.1 Type culture preparation

A cryopreserved bead of *S. aureus* ATCC 9144 was transferred in 10 ml TSB and incubated at 37°C for 18 hours. The following day, the optical density of the recovered culture was adjusted to 0.5 at 450 nm with TSB. This was used as the inoculum.

### 2.5.2 Seeded square agar plate preparation

Two large square plates (245 × 245mm dish; Corning Inc.) were placed on a level surface. One plate was used for testing the total antibacterial activity of honeys and the other one for the non-peroxide activity.

Two flasks of autoclaved 150 ml nutrient agar were melted in boiling water for 30 min then maintained in a 45°C water bath for 30 min. Into each was transferred 100 µl of *S. aureus* ATCC 9144 inoculum, and the agar was swirled well without causing bubbles to be incorporated, then poured into the square plates evenly. The agar plates were covered with a cloth with the lids on, left on the bench for one hour and then stored at 4°C for overnight.

### 2.5.3 Antibacterial activity test

A paper sheet numbered with a quasi-Latin square was placed under the plate as a template so that each honey sample would be placed randomly (Figure 2.1), then 64 wells were cut on each agar plate with a cooled flamed 8 mm diameter cork borer.

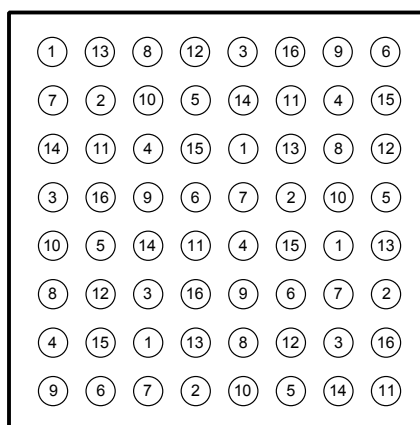

Figure 2.1: The illustration of the square agar plate with a numbered quasi-Latin square template for antimicrobial activity testing.

A solution of honey in water was prepared for testing the antibacterial activity of the honey samples. To 5 ml sterile purified water in a universal bottle was added 5 g by weight of honey (equivalent to 3.65 ml of honey) to obtain a 50% (w/w) (equivalent to 42.2%, v/v) solution of honey. The bottle was closed and warmed in a 37°C water bath for 10 min with occasional stirring to aid mixing. The 50% (w/w) honey solution was then further diluted to 25% (w/w) by mixing in sterilised bijou bottles 1 ml of the 50%

(w/w) honey solution with 1 ml sterile purified water or 1 ml of a solution of 0.2% catalase solution (0.02 g catalase powder dissolved in 10 ml of purified water. Catalase from bovine liver; 1700 units/mg solid; 2150 units/mg protein; SIGMA Cat No. C9322). The final concentration of catalase in the 21.1% (v/v) honey solution would be 0.1%, a concentration that would be enough to remove hydrogen peroxide from the honey solution (Allen et al., 1991a).

A series of concentrations of phenol standard solution (2%, 3%, 4%, 5%, 6% and 7% w/v) was made by dissolving phenol in sterile purified water. The standard solutions were stored in a dark refrigerator when not in use.

Honey solutions (100  $\mu$ l of each) were loaded in quadruplicate into the wells in accordance with the quasi-Latin square sheet, also 100  $\mu$ l of each phenol standard in quadruplicate, then the plates were incubated at 37°C for 18 hours.

After the overnight incubation, the diameter of any inhibition zones on each agar plate was measured in mm with a digital callipers (Mitutoyo CD-6"), twice at right-angles to each other. The mean diameter for each zone and then the square of the mean diameter was calculated. A standard curve of % phenol against the squared mean diameter of the zones around the phenol solutions was plotted. A linear regression equation was obtained and the equivalent phenol concentration (w/v) of the diluted honey solutions was calculated accordingly from the squared diameter of the zones from these. The antibacterial activity of the original honey samples was then obtained by multiplying by the dilution factor (4.69).

## 2.6 The track dilution method

For viable cell counting, the track dilution technique (Jett et al., 1997) was used instead of the regular spread plate technique because the former

requires much less media and plates and, most importantly, takes much shorter time to carry out than the latter. The time shortening is essential particularly when handling microaerobes and anaerobes as this reduces the risk of the loss of their viability in the air. It generally takes approximately 15–20 min to allow excess moisture absorption on the agar surface with the spread plate method, whereas the track dilution technique takes only 2–5 min.

The track dilution method used was slightly modified from that reported by Jett et al. (1997). An incubated broth culture was serially diluted in 10-fold steps in sterile saline to get 8 dilutions of the culture ( $10^{-1}$ ,  $10^{-2}$ ,  $10^{-3}$ ,  $10^{-4}$ ,  $10^{-5}$ ,  $10^{-6}$ ,  $10^{-7}$  and  $10^{-8}$ ), then 10  $\mu\text{l}$  of each dilution was loaded as spots along one edge of an agar plate in a 100 mm  $\times$  100 mm square Petri dish (Techno-Plas Co.), then this edge of the plate was tipped up by a  $45^{\circ}$ – $90^{\circ}$  angle so that the diluted cultures ran down toward the opposite edge. The plate was allowed to dry on the benchtop for 30 seconds and then incubated under appropriate conditions. After incubation the dilution with which the colony number ranged between 30–300 was chosen and the colony-forming units were recorded (Figure 2.2).

The cell density of the undiluted broth culture was calculated using the following equation:

$$\text{Cell density (CFU/ml)} = \frac{\text{Colony count}}{10\mu\text{l}} \times 10^3 \times \text{Dilution factor} \quad (2.1)$$

As an example, in Figure 2.2 the track with 133 CFU is chosen for calculation, therefore the initial density of the culture would be

$$\text{Cell density (CFU/ml)} = 133 \times 10^2 \times 10^3 = 1.33 \times 10^7 \text{CFU/ml} \quad (2.2)$$



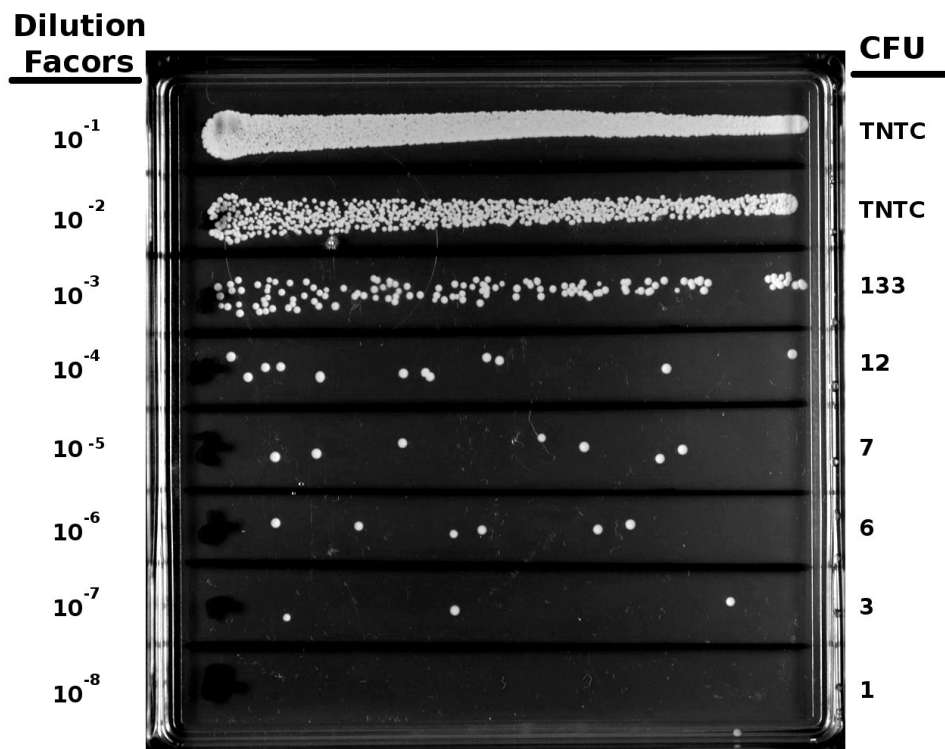

Figure 2.2: The serial diluted culture spread on a square agar plate. CFU: colony forming units. TNTC: too numerous to count. In this example the track with 133 CFU, on which the culture is diluted by  $10^3$ -fold, is chosen, and thus the initial density would be  $1.33 \times 10^7$  CFU/ml.

## SPIRITS BURN METHOD FOR CULTURING NON-AEROBIC ORGANISMS

---

As some gastrointestinal bacteria used in this project are not aerobes whereas a large expense would be incurred if gas generating systems with a GasPak are purchased, it was necessary to seek an alternative solution instead of using commercial gas generating systems. This chapter describes the evaluation of a simple and cost-effective gas generating system for culturing non-aerobes.

The frequently used methods for culturing non-aerobes, including commercial and non-commercial, are described. The utility of the different gas generating systems are studied practically by comparing the growth rate and colony size of various microaerobes (*Campylobacter*, *Helicobacter*, *Lactobacillus*, *Bifidobacterium*, *Haemophilus*) and anaerobes (*Clostridium*, *Propionibacterium*, *Bacteroides*) in different gas generating systems. The advantages and disadvantages for each method are discussed.

### 3.1 Introduction

The successful isolation and culture of some bacteria is largely dependent on conditions such as temperature, oxygen and media requirement. In order to obtain reliable culturing of non-aerobic organisms, several gas generating systems have been developed.

With commercial methods gas chambers and gas-pack systems are usually used. The gas chamber has been the “gold standard” for non-aerobes as it has the merit of adjusting the gas mixture to meet the requirement of the growth of the cultures. For middle- to small-scale laboratories that are unlikely to be able to afford a gas chamber, several types of gas-pack systems are available on the market. However, the cost of gas-pack system may still be prohibitive to small laboratories, and also it takes 30 min–2 hours to generate a microaerobic or anaerobic atmosphere in accordance with manufacturer’s instruction (<http://www.mgc.co.jp/eng/products/abc/anaeropack/kenki.html> [accessed: 12/May/2009]), during which time the bacteria are subjected to a range of atmospheric conditions.

Several culturing methods associated with non-commercial gas systems have also been developed. [Karmali and Fleming \(1979\)](#) used the Fortner’s principle to isolate *Campylobacter* from stools. In this report Karmali et al. utilised the ability of facultative anaerobes such as *Proteus rettgeri*, *S. aureus*, *E. coli*, *Klebsiella aerogenes* or *P. aeruginosa* to reduce the oxygen tension in a closed environment so that the growth of oxygen-sensitive organisms such as *C. jejuni* was possible. However, the growth of *C. jejuni* did not occur if the other organisms were not concomitantly cultured onto the same agar plate. [Pennie et al. \(1984\)](#) used steel wool to react with oxygen in the atmosphere to produce a suitable environment for *C. jejuni*. The candle jar ([Reddy et al., 2007](#)) is one of the most well known non-commercial methods for culturing microaerophilic organisms. In this old-fashioned

device the burning of the candle consumes some oxygen and also produces CO<sub>2</sub> in the atmosphere. Morshed et al. (1995) used a candle jar to grow *H. pylori*. The candle jar has also been used for cultivating *Actinomyces actinomycetemcomitans* (Slots, 1982), meningococci (Goldschneider et al., 1969), *Neisseria gonorrhoeae* (Punsalang and Sawyer, 1973), *Bartonella koehlerae* (Droz et al., 1999), *H. influenzae* (Thornsberry and Kirven, 1974) and *Bordetella holmesii* (Weyant et al., 1995). However, the candle jar method has also been criticised as being unreliable when compared with commercial gas systems. As the reduction of oxygen in a candle jar may not be sufficient for some microaerobes, its application is limited (Bolton and Coates, 1983; Luechtefeld et al., 1982; Wang et al., 1982; Wang and Luechtefeld, 1983).

The spirits burn method, originally described by Ribeiro et al. (1985), was reported to leave 10.5–14% oxygen in the jar, and this concentration is acceptable for most of the microaerobes. Popovic-Uroic and Sterk-Kuzmanovic (1992) compared the spirits burn method with the Fortner's principle and found it to be superior. However in these two reports only a very limited number of species were tested with the spirits burn method (*C. jejuni*, *C. coli* and *C. laridis* by Ribeiro et al.; *C. jejuni* and *C. coli* by Popovic-Uroic and Sterk-Kuzmanovic) and it is unknown whether or not the method would be applicable to other microaerophilic organisms.

The performance of the non-commercial methods has never been compared with that of the commercial methods. As the work described in this thesis frequently used several non-aerobes, it was essential to seek an economical incubation method rather than using commercial gas-pack apparatus for cultivating microaerobes because this would otherwise have exceeded the funds available with the large volume of work to be carried out. The purpose of this study was therefore to compare the utility of the spirits burn method for several common non-aerobes. The growth of the bacterial cultures was compared in all of the systems.

## 3.2 Gas generating systems evaluated

### 3.2.1 *AnaeroPack system*

The GasPak system (MGC AnaeroPack™, Mitsubishi Gas Chemical Company Inc.) consists of a 2.5 l jar and an AnaeroPack sachet. The sachet was opened and put into the jar along with the inoculated culture media and an anaerobic indicator strip (BBL GasPak disposable anaerobic indicator. Cat. No: 70504). The jar was incubated at 37°C.

### 3.2.2 *CO<sub>2</sub> incubator*

Cultures were incubated in a Sanyo CO<sub>2</sub> incubator (Sanyo MCO-17AIC) connected with a food grade CO<sub>2</sub> cylinder, size D 6 800 l. The CO<sub>2</sub> injection was set to 5% and the temperature to 37°C. A small amount of sterilised water was placed inside in a pan to maintain the humidity in the incubator.

### 3.2.3 *Candle jar*

A storage tins (3.5 l) was purchased from a local shop. A 3 cm candle was fixed in a glass Petri dish and was lit with a lighter. This was placed in the 3.5 litre tin along with the inoculated culture media and covered with the tin's lid. The tin was sealed with a strip of adhesive vinyl tape to avoid air leakage and incubated at 37°C for the appropriate time (Table 3.1).

### 3.2.4 *Spirits burn method*

The same tin (3.5 l) as used for the candle jar was used in this method. A glass Petri dish was used to contain 500 µl of methylated spirits. The amount of methylated spirits can be increased proportionally if a larger tin is required. The Petri dish was placed on top of the uppermost Petri dish containing the inoculated media in the tin. The methylated spirits was lit with a lighter right before the lid was placed on the tin. The lid was sealed with a strip of adhesive vinyl tape to avoid air leakage and then was incubated at 37°C.

## 3.3 Comparison of the growth of non-aerobes

### 3.3.1 *Bacterial cultures and media*

The cultures used for comparison of growth were: *C. jejuni* ATCC 33560, *C. coli* ATCC 33559, *C. fetus* ATCC 27674, *H. pylori* ATCC 43504, *L. rhamnosus* ATCC 2469, *L. plantarum* ATCC 1100, *B. animalis* subsp. *lactis* and *H. influenzae*. Although not being a microaerobe, *H. influenzae* was included in the test because the candle jar and CO<sub>2</sub> incubator are usually used to cultivate this species in clinical disciplines. The incubation conditions used are summarised in Table 3.1.

### 3.3.2 *Culture preparation*

Each culture was recovered by rubbing the surface of a frozen culture with a sterilised cotton swab then streaking this onto an appropriate agar as listed

in Table 3.1. Microaerobes were incubated with the spirits burn method and anaerobes in a gaspack jar. Most organisms were incubated overnight except that *Campylobacter* were incubated for 2 days and *H. pylori* for 3 days.

The recovered colonies were collected with a cotton swab and suspended in 0.85% (w/v) sterile saline. The optical density at 625 nm was adjusted to 0.08 with saline then was further diluted by 300 fold using suitable broth media. This gave a final culture density of approximately  $10^5$  cfu/ml and was used as the inoculum for the comparisons of the incubation systems.

### 3.3.3 Comparison of the performance of the gas generating systems

The evaluation of the performance of gas generating systems was done in two ways. The growth in broth media was evaluated by comparing the ratio of CFU/ml before incubation with that of after incubation in each gas system. On the other hand, the performance on agar plates was evaluated by comparing the size of the colonies after incubation.

Table 3.1: Incubation conditions for the comparison of non-aerobic culture systems. CHB: Columbia horse blood; BHIYE: Brain heart infusion yeast extract; MRS: de Man Rogosa and Sharpe; HMB: *Haemophilus* medium base; -A: agar; -B: broth.

Organisms	Media	Incubation period (Days)
<i>Campylobacter</i> spp.	CHB-A, BHIYE-B	2 days
<i>H. pylori</i>	CHB-A, BHIYE-B	3 days
<i>Lactobacillus</i> spp.	MRS-A, MRS-B	2 days on agar, 1 day in broth
<i>B. animalis</i> subsp. <i>lactis</i>	MRS-A, MRS-B	2 days on agar, 1 day in broth
<i>H. influenzae</i>	HMB-A, HMB-B	1 day

### 3.3.3.1 Viable count determination

The viable counts for each broth culture before and after incubation in each gas systems were performed with the track dilution technique on appropriate agar plates.

As the initial cell density in each medium may not always be the same, growth rate instead of the final cell density was used for evaluating the cell growth in each gas system. Viable counts before and after incubation were recorded and the growth rate in each gas system was calculated with the following equation:

$$\text{Growth rate} = \log_{10} \left( \frac{\text{CFU/ml after incubation}}{\text{CFU/ml before incubation}} \right) \quad (3.1)$$

Each plate count was performed in duplicate. The growth rate in all gas generating systems were compared using one-way ANOVA.

### 3.3.3.2 Colony size evaluation

All inocula were quadrant streaked with 10  $\mu\text{l}$  loops on the appropriate agar plate. The largest colony diameter for each culture was measured in millimetres with digital callipers. Each evaluation was performed in duplicate. The colony size in all gas generating systems were compared using one-way ANOVA.

## 3.3.4 Results

The rate of growth of the cultures and the size of the colonies obtained in the various gas systems are presented in Figures 3.1 and 3.2. Overall the results obtained using the spirits burn method were equivalent to or superior to the commercial GasPak, CO<sub>2</sub> incubator or candle jar methods.



The viable count results (Figure 3.1) showed that most microaerobes used in this work grew with the spirits burn method as well as or better than in the CO<sub>2</sub> incubator, GasPak or candle jar. Mostly the results with the spirits burn method were better than with any other method. Although CO<sub>2</sub> is generally required for stimulating the growth of *H. influenzae*, the spirits burn method was found to be as beneficial to its growth as the CO<sub>2</sub> incubator.

The colony size (Figure 3.2) revealed similar trends as with growth rates. Generally most cultures formed larger colonies with the spirits burn method than the other methods. For *H. pylori*, environments other than the spirits burn jar failed to give colonies on agar plates.

An interesting thing in the results is that *Bifidobacterium* and Lactobacilli grew vigorously in all tested conditions, regardless of the species being anaerobes. This suggested a probability that non-commercial gas systems may support the growth of some anaerobes. This hypothesis motivated the author to further test the gas systems with some anaerobes in the next section.

## 3.4 The comparison of the growth of anaerobes

### 3.4.1 *Bacterial cultures and media*

The cultures of anaerobes used for the comparison of the growth were: *P. acnes*, clostridia (*Clostridium butyricum*, *C. difficile*, *C. perfringens*, *Clostridium sporogenes* and *Clostridium tetani*), *Bacteroides* (*Bacteroides fragilis*, *Bacteroides stercoris* and *Bacteroides ureolyticus*). The incubation conditions used are summarised in Table 3.2. All cultures were incubated overnight except that with *P. acnes* it was for 7 days.

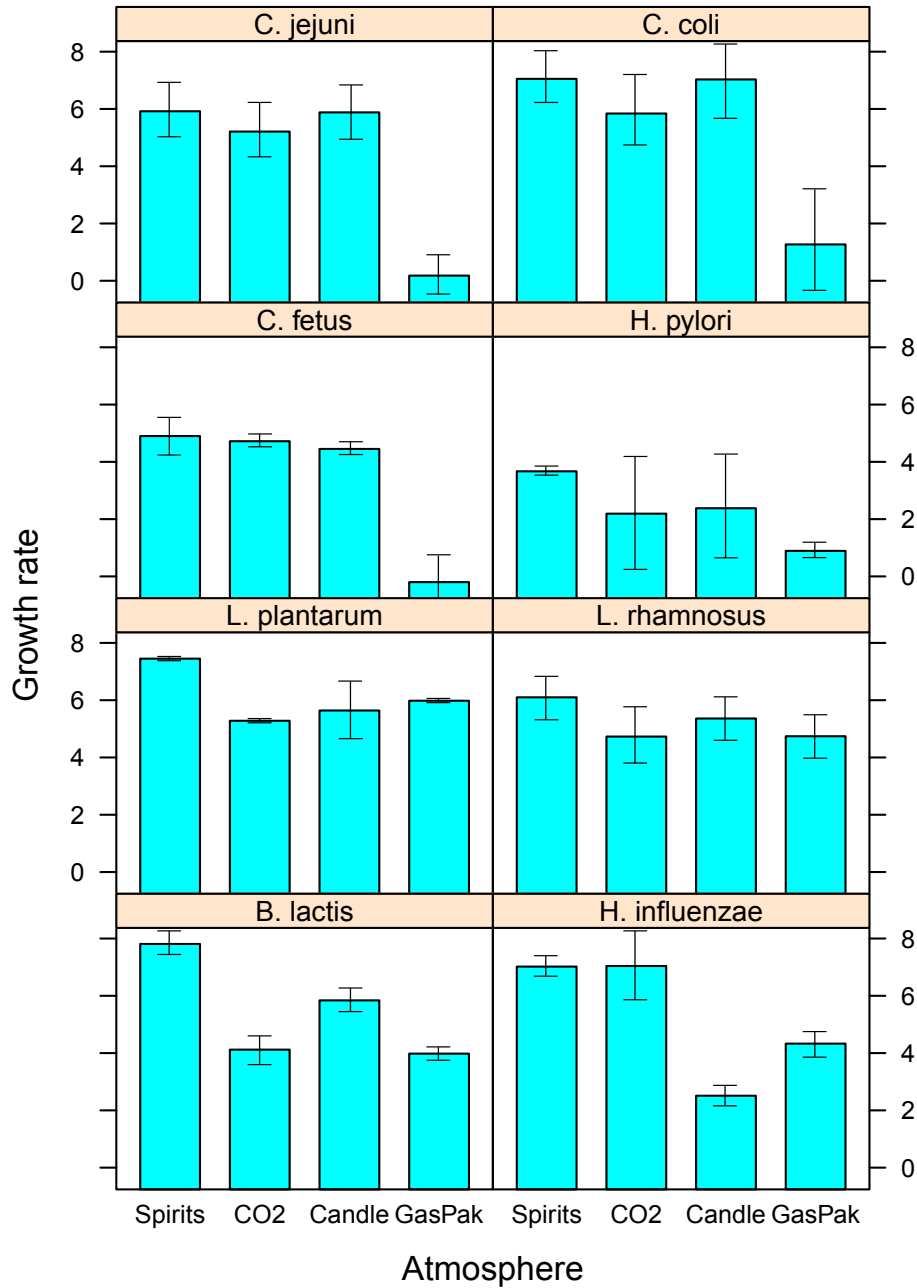

Figure 3.1: The growth rates of micro-organisms when cultured in broth under different atmospheres. The growth rates were obtained from the formula  $\log_{10} \left( \frac{\text{CFU/ml after incubation}}{\text{CFU/ml before incubation}} \right)$  and are represented as the mean from duplicate determinations.

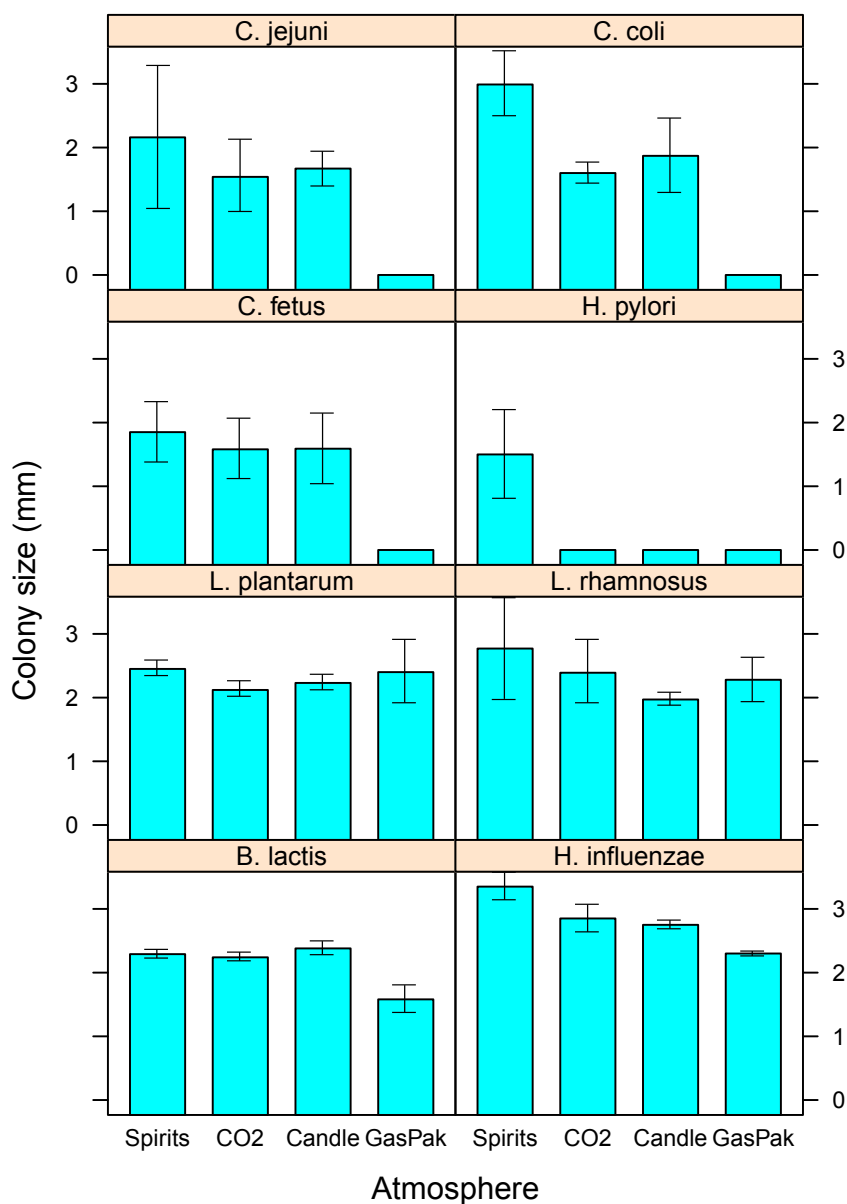

Figure 3.2: Colony diameter (mm) when cultured in different atmospheres. The values are represented as the mean from duplicate determinations.

Table 3.2: Incubation conditions for the comparison of anaerobic culture systems. RCM: Reinforced clostridial medium; -A: agar; -B: broth.

Organisms	Media	Incubation period (Days)
<i>Clostridium</i> spp.	RCM-A, RMC-B	1 day
<i>P. acnes</i>	RCM-A, RMC-B	7 days
<i>Bacteroides</i> spp.	RCM-A, RMC-B	1 day

The evaluation was carried out by cultivating the bacteria both in broth and on agar plates as described previously. In a preliminary test it was shown that the growth of the anaerobes in RCM broth was visually identical in all gas system. Also, anaerobes were not the main subject in this thesis. Therefore, it was decided that the evaluation be recorded by identifying whether or not the anaerobes grow in the tested conditions (*i. e.* observe visually the increase in turbidity), rather than examining the CFU/ml as was done in the previous section.

### 3.4.2 Results

The result for the growth of anaerobes in gas systems are shown in Table 3.3. It was found that all tested anaerobes were able to grow in broth whereas in all but the GasPak there was no growth on the agar plates. *P. acnes* was the only species that failed to grow on the agar plate in all gas conditions. Columbia agar plates supplemented with 5% sheep blood were also tried in addition to RCM for *P. acnes*, but the species still did not form any colonies in any conditions even if the incubation was prolonged up to 2 weeks.

## 3.5 Discussion

Overall the results obtained using the spirits burn method were equivalent or superior to those obtained using a commercial GasPak, a CO<sub>2</sub> incubator or a candle jar.

For most *Campylobacter* spp. and for *H. pylori* it is recommended that O<sub>2</sub> should be reduced down to 5–7% (Corry et al., 1995; Versalovic and Fox, 2003). To achieve this environment in a small / middle-scale laboratory, the GasPak method or candle method is usually used. In the viable count

Table 3.3: Growth of anaerobes in different gas systems. +: growth visible. -: no visible growth.

Cultures	Spirits		Candle		CO <sub>2</sub>		Gaspak	
	Broth	Agar	Broth	Agar	Broth	Agar	Broth	Agar
<i>Clostridium butyricum</i>	+	-	+	-	+	-	+	+
<i>Clostridium difficile</i>	+	-	+	-	+	-	+	+
<i>Clostridium perfringens</i>	+	-	+	-	+	-	+	+
<i>Clostridium sporogenes</i>	+	-	+	-	+	-	+	+
<i>Clostridium tetani</i>	+	-	+	-	+	-	+	+
<i>Propionibacterium acnes</i>	+	-	+	-	+	-	+	-
<i>Bacteroides fragilis</i>	+	-	+	-	+	-	+	+
<i>Bacteroides stercoris</i>	+	-	+	-	+	-	+	+
<i>Bacteroides ureolyticus</i>	+	-	+	-	+	-	+	+

test it was found that cultures of these species could be raised satisfactorily in either the spirits jar, CO<sub>2</sub> incubator or candle jar, with the spirits jar generating the highest growth rate. However, it was observed that *H. pylori* failed to form colonies in the colony size test in either the CO<sub>2</sub> incubator, the candle jar or GasPak (Figure 3.2) whereas the growth was observed in the broth media (Figure 3.1) under these atmospheric conditions.

The failure of the candle jar is not surprising, albeit, in theory, the amount of oxygen consumed and CO<sub>2</sub> generated should be similar, if not identical, by burning a candle or burning methylated spirits. In fact, *H. pylori* during the evaluation sometimes formed colonies whereas at other times it did not. It was noticed that the burning time of the candle in a jar varied significantly, which may consequently have led to the difference in the amount of oxygen consumed in the jar. Indeed, it was also observed that the flame of the candle lasted for a markedly shorter time if the exposed wick was too short, because then the flame would easily be extinguished by the melted wax that was on the top of the candle (Figures 3.3(a) and (b)). Therefore the consumed oxygen in a candle jar may differ from time to time, and perhaps this is why a candle jar is sometimes thought to be unreliable

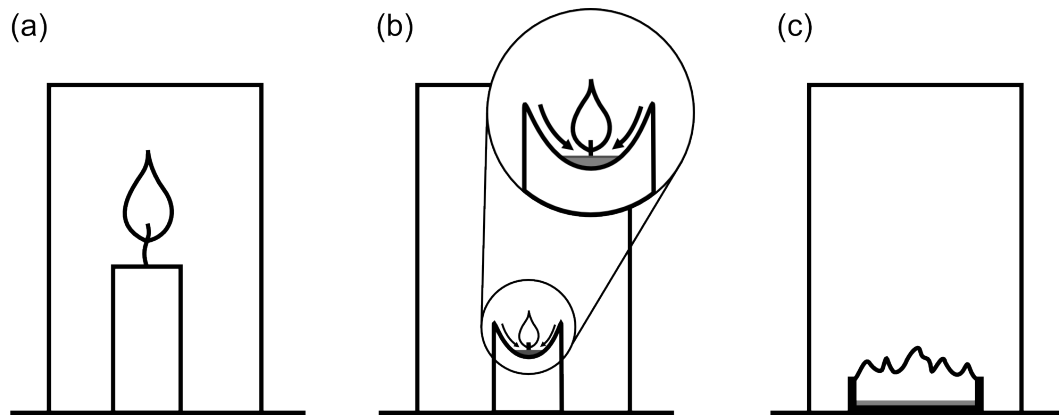

Figure 3.3: (a) In theory, the candle in an air-tightened jar should reduce oxygen concentration and generate a microaerophilic environment; (b) in reality, however, the melted wax flows into the cavity on the top of candle and the flame is extinguished before the oxygen in the jar is fully consumed. On the other hand, (c) the flame by burning methylated spirits is consistent each time because it will continue to burn until there is no oxygen left in the jar as long as there is sufficient volume of the alcohol in the glass Petri dish.

(Bolton and Coates, 1983; Luechtefeld et al., 1982; Wang et al., 1982; Wang and Luechtefeld, 1983), especially when cultivating fastidious microaerobes like *H. pylori* on the surface of an agar plate. On the other hand, the flame of burning methylated spirits was consistent each time because the volume of spirits is the only factor that may affect the duration of the flame, which is relatively easy to control (Figure 3.3(c)).

Another possible explanation for the difference between the spirits burn method and the candle jar is that the large surface area of the flame in the dish of alcohol made the production of  $\text{CO}_2$  and the reduction of  $\text{O}_2$  more efficient. The candle was also found to be releasing smoke right after the flame extinguished which was not observed in the spirits burn method, and this may have a negative effect on some fastidious organisms.

The composition of the atmosphere appears to be less critical for broth cultures, as can be seen from Figure 3.1, all of the microaerobes being cultivated successfully in all of the atmospheres. In the viable count test all cultures were incubated in the broth in various atmospheres and then inoculated on the agar plates which were then incubated in the spirits burn

jar, whereas in the colony size test the microaerobes were inoculated directly on the agar plates which were then incubated in various atmospheres. It is possible that the broth media provided the cultures with a protection from inappropriate atmospheres; the broth may reduce the chance of air contacting the bacterial cells directly whereas on the surface of agar there is no protection provided to the cells. When cultured directly on an agar surface, only the spirits burn method allowed colonies to form whereas when broth culture were used *H. pylori* multiplied in all microaerobic conditions by 2–4 log<sub>10</sub>.

The protection to the broth culture seems to be applicable to anaerobes too (Table 3.3). Not surprisingly, the atmosphere generated by the spirits burn method is not suitable for *Clostridium* and *Bacteroides* species on the agar surfaces, as the concentration of the oxygen left in the jar is unacceptable for obligate anaerobes (Ribeiro et al., 1985). The growth of anaerobes in broth culture was reasonably good in all atmosphere conditions including the spirits burn method and the candle jar. Although detailed viable count and colony size tests were not carried out with anaerobic species, this might suggest that the non-commercial gas systems could also be used for incubating anaerobes in broth media as an economical alternate. It would be of interest to test this with other anaerobes in the same condition in future work.

CO<sub>2</sub> is usually required to stimulate the growth of some cultures such as *H. influenzae*. The results revealed that the CO<sub>2</sub> incubator provided a good environment for this species and it is interesting to note that the spirits burn method and the candle jar were as efficient as the CO<sub>2</sub> incubator, although the candle jar appeared to be relatively unstable.

For species generally used as probiotics (*L. plantarum*, *L. rhamnosus* and *B. animalis* subsp. *lactis*) all tested atmospheres were found to support their growth. It is interesting that although *B. animalis* subsp. *lactis* is generally

considered to be an anaerobe, non-GasPak methods seem to be applicable for the species even on the agar surfaces.

The spirits burn method also has several potential other advantages over other gas generating systems. With the spirits burn method, a more rapid production of a microaerobic condition could be achieved than with the commercial GasPak system. According to the manufacturer's instruction (<http://www.mgc.co.jp/eng/products/abc/anaeropack/kenki.html> and <http://www.mgc.co.jp/eng/products/abc/anaeropack/bikouki.html> [accessed 16/06/08]), it takes about 30 min–2 hours to generate a microaerophilic or anaerobic atmosphere. On the other hand, the spirits burn method takes only a few seconds to reduce the oxygen in the jar. The fast reaction reduces the potential risk of the organisms being exposed to oxygen at the initial stage of the incubation.

The spirits burn method generates moderate humidity in the jar at the very first stage which can be observed from dense condensation of water on the wall of the tin, bottles and Petri dishes. As several organisms such as *Campylobacter* spp. and *Helicobacter* spp. prefer humid condition for their growth (Fraser et al., 1992; Versalovic and Fox, 2003), this may also help the growth of such cultures. Furthermore, the flame warms the container at the start and therefore may reduce the time required to reach the optimum temperature for growth of the bacteria.

The spirits burn method has a significant advantage over other systems when considering simplicity. According to the instruction from the manufacturer, the GasPak needs to be sealed in a jar within 1 minute after tearing open the outer foil to achieve maximum performance as the reaction starts right after opening the sachet. This also means the paper sachet is not re-usable should air leakage or any mistake be found afterwards. On the other hand, the reaction would not start with the spirits burn method or the candle jar until a flame is lit, and also the whole process can be



repeated if necessary. Unlike candle jars, no melted candle wax, which is hard to clean out, is produced with the spirits burn method. Although the CO<sub>2</sub> incubator has the same advantage, the concentration of the CO<sub>2</sub> may fluctuate when opening the door and handling plates or bottles. The acidity of media may also increase due to the formation of carbonic acid under long term incubation and this may affect the result of antibiotic susceptibility tests.

Cost saving may be one of the most significant merits of the spirits burn method over the commercial solutions. With the spirits burn method, a 3.5 l or 11.5 l incubation size requires only 500 µl or 1.5 ml of alcohol, respectively. On the other hand, the MGC GasPak system recommends 1 sachet for a 2.5 l jar or 3 sachets for a 7.0 l jar and the cost per test would be over one thousand times more expensive than that of the spirits burn method (Table 3.4).

### 3.6 Safety issues

As this method uses only a small volume of spirits, there should be minimal concern about the combustion. Also the 'transparent' flame has never been a safety issue as it is limited to the Petri dish and extinguishes within seconds. However caution should be made when sealing the container with vinyl tape as the flame heats up the top of the lid and may burn the hand holding it. Wearing cotton gloves when sealing the tape, or, alternatively, marking the position of the Petri dish on the lid and keeping hands away from the area should avoid the hazard.

Table 3.4: Cost comparison between gas generating systems.

Gas system	Price (NZ\$)	Package	Amount for 1 test*	Cost per test (NZ\$)*	Life span†	Maximum capacity (plates)
Spirits	\$5.99	1 litre	500 µl	0.3¢	> 2 years	20
GasPak	\$70.00	20 sachets	1 sachet	\$3.50	1-4 weeks	13
CO <sub>2</sub>	\$28.04	6.8 litre	194 ml (/day)	\$0.8 (/day)	< 5 weeks	300

\* Test in a 2.5 litre jar.

† At the pace of daily usage in our laboratory.

### 3.7 Conclusion

The spirits burn method gives a significant improvement over the candle jar, and it is also concluded that commercial gas generating systems are not necessarily always required to cultivate cultures of non-aerobic species. Although not specifically tested in this study, it might also be useful for cultivating other microaerobes and even anaerobes in a budget-constricted laboratory. On the basis of these findings, the technique was used wherever microaerophilic conditions were required in the studies described in this thesis.

## SUSCEPTIBILITY OF ENTEROBACTERIA TO HONEY

---

As the aim of this study was to evaluate if manuka honey is likely to be useful for gut infections, it was necessary to first find how susceptible the gastrointestinal bacteria are to the honey.

In this chapter the minimum inhibitory concentration (MIC) and minimum bactericidal concentration (MBC) of manuka honey and artificial honey to common pathogenic gastrointestinal bacteria were tested using the broth microdilution method. The susceptibility of probiotics was also measured to find if they would be likely to survive the treatment of enteric infections with honey.

Part of the work in this chapter has been published (see Appendix): Lin, S.M. Molan, P.C. and Cursons, R.T. (2009). The *in vitro* susceptibility of *Campylobacter* spp. to the antibacterial effect of manuka honey. 28(4):339–344.

## 4.1 Introduction

### 4.1.1 *Honey and gastrointestinal pathogens*

As pointed out in Chapter 1, bacterial gastrointestinal disorders are one of the most common clinical diseases. These are largely caused by, but not limited to, *Enterobacteriaceae* (*E. coli*, *Shigella*, *Enterobacter*, *Yersinia*), *Salmonella*, *Campylobacter* and *H. pylori*. Several “opportunistic” microorganisms such as *C. difficile* may be associated with gastroenteritis although they normally do not cause disease (see Chapter 1).

Honey has been reported to show a significant antibacterial activity against a wide range of bacteria (reviewed in Chapter 1), but those reports of efficacy of honey are not always comparable with each other for several reasons. On the one hand, the detail on the honey being tested is not clearly given. For instance, [Badawy et al. \(2004\)](#) compared the antibacterial activity of four Egyptian clover honey samples, each of which had been stored for a different period of time (7 months, 12 years, 16 years and 21 years) against *E. coli* O157:H7 and *S. typhimurium* and reported that the activity declined with time. However, [Badawy et al. \(2004\)](#) did not state whether honey samples had been stored at room temperature or in a dark refrigerator but it is known that antibacterial activity of honey is sensitive to light and to heat ([Molan, 1992b](#)). In some reports (for example, [Adebolu \(2005\)](#) and [Obi et al. \(1994\)](#)) even the floral source of the tested honey was not given but the activity of honey can vary greatly among different floral types ([Allen et al., 1991b](#)). It has also been known that the potency of honeys sharing the same floral source could differ in activity by up to 100-fold [Molan \(1992b\)](#). Therefore, it is necessary to have the antibacterial activity of honey standardised.

On the other hand, many published reports failed to give details on the bacteria being tested such as the inoculum density. As the more bacterial cells there are in the testing environment, the more likely for the bacteria to overcome the toxicity of antibacterial agents, it is important to state the number of the cells being involved in the assessment of an antibacterial agent.

The objectives of this study were to investigate the antibacterial activity of a standardised manuka honey against a number of standardised number (inoculum density) of type strains and clinical isolates of gastrointestinal pathogens from patients with diarrhoea. Additionally, to understand the potential impact of the antibacterial activity of manuka honey on normal flora, the sensitivity of some probiotic species to manuka honey was also examined in this chapter. The data obtained in the study in this chapter were also used as the basis for the work in the following chapters.

## **4.2 Materials and methods**

### ***4.2.1 Honey samples used in this study***

Manuka honey samples (internally labelled as M113 in the Honey Research Unit laboratory collection) from Bee & Herbal NZ Ltd. and from Summer-Glow Apiaries Ltd. (labelled M115 in the laboratory collection) were used for testing the susceptibility of gastrointestinal bacteria to manuka honey. These honeys were labelled “UMF 16+” on their packages, and were therefore supposed to have a minimum antimicrobial activity equivalent to 16% phenol. However, it was not realised until the susceptibility tests with some species (*C. difficile* and *Campylobacter* spp.) had been done that these honeys had antimicrobial activity equivalent to that of 29.4% and 16.5% phenol,

respectively, when checked with the method reported by [Allen et al. \(1991a\)](#) as described in Section 2.5. The M113 batch had an exceptionally high non-peroxide activity, nearly twice as high as it was labelled. Consequently, the MIC and MBC results obtained using the honey sample M113 with nearly twice the antibacterial potency would be expected to be approximately half of those using manuka honey M115 (Peter Molan personal communication). Therefore, in this chapter most microorganisms were tested with manuka honey sample M115, the honey sample with a medium-level activity, except that *Campylobacter* spp. and *C. difficile* were tested with M113. An artificial honey was included in this test to simulate the sugar composition of honey (see Section 2.3). The honey samples were stored in a dark refrigerator until used.

#### **4.2.2 Bacterial strains and culture media used in this study**

*E. coli*, *S. typhimurium* DT104, *S. enteritidis*, *E. aerogenes*, *E. cloacae*, *S. flexneri*, *S. sonnei*, *Y. enterocolitica*, *Campylobacter* spp., *H. pylori*, *Lactobacillus* spp. and *B. animalis* subsp. *lactis* were used in the susceptibility test in this chapter. See Table 2.2 for the culture media used for the work in this chapter.

#### **4.2.3 Cell density control**

For most non-fastidious organisms, each culture was recovered from cryop-reservative beads by transferring one bead into 10 ml MHB then incubating at 37°C overnight. The optical density of the recovered culture was adjusted to 0.08 at 625 nm by addition of MHB and then was further diluted 300-fold (10 µl culture in 3 ml MHB). This was used as the inoculum for the susceptibility testing.

The anaerobes *B. animalis* subsp. *lactis*, *Lactobacillus* spp. and *C. difficile* were handled similarly except that these were cultured with MRS (*B. animalis* subsp. *lactis* and *Lactobacillus* spp.) and RCM (*C. difficile*) in GasPak canisters instead of with MHB in the ambient atmosphere.

For the fastidious species *Campylobacter* and *H. pylori* each isolate was recovered by rubbing the surface of the frozen stock culture with sterilised cotton swabs then streaking it onto blood-free *Campylobacter* selective agar and CHBHP agar, respectively, followed by incubating microaerobically at 37°C for 48 h and 72 h, respectively. The recovered colonies were collected with cotton swabs and suspended in fresh MHB. The optical density at 625 nm was adjusted to 0.08 with fresh MHB then was further diluted 300-fold.

The broth cultures prepared with the method described above had a final culture density of approximately  $3 \times 10^5$  cells/ml which was confirmed with the track dilution method as described in Chapter 2. These were used as the inocula through the sensitivity testing repeated in this chapter.

#### 4.2.4 *Honey preparation*

Double-strength solutions of manuka honey and artificial honey were prepared with pure water, then an equal amount of double-strength MHB, MRS or RCM broth (prepared by adding twice the recommended amount of broth powder in pure water) was added to make single-strength manuka honey and artificial honey solutions. These single strength honey solutions were considered as the “original” honey solutions. For example, to make an original honey solution of 40% (v/v), 4 ml of honey (measured as 5.48 g, as honey has an average density of 1.37 g/ml) was added to 1 ml of pure water in a universal bottle and then placed in a 37°C water bath for 5 min to aid dissolving. After mixing with a wooden stick, the 5 ml of double strength



honey (80%) was added with 5 ml of double strength broth to achieve the desired final concentration (40%).

The original honey solutions made with MHB and MRS broths were filter-sterilised with 0.2 µm filters (Sartorius Co.) before serial dilution. The original honey solution made with RCM broth, however, was not able to be filter sterilised because RCM broth contains a small amount of agar as a protectant, which makes it impossible to pass through the filter membrane.

Because the MIC and MBC of artificial honey would presumably be higher than that of manuka honey, the concentration of original artificial honey used was twice as high as that of original manuka honey in the test. A higher concentration of original honey solution was used if the MIC appeared to be higher than the detectable range of the MIC test. Up to 50% original honey solution (16.6% after inoculating broth culture as stated in the following sections) was made. It is unlikely that the ingested honey would be at as high level as 20% in the gut because the high osmolarity would inhibit emptying of the stomach (Peter Molan personal communication). If an even higher concentration of honey was found to be required to inhibit the growth of the tested microorganisms, the MIC was recorded as "> 16.6%".

#### **4.2.5 *Honey serial dilution***

For facultative anaerobes and microaerobes, a broth microdilution method on microplates was used. Of the 12 wells in each column in a microplate, to the first was added 40 µl honey solution, and to the remaining 11 wells were added 40 µl MHB. For serial dilution, 160 µl honey solution was added into the second well in the column and then 160 µl was sequentially transferred to the following wells till the tenth well. The last two wells served a growth control (culture and broth added but no honey) and sterility check (plain

broth). After that 80 µl of inoculum was added into each well except the last well in which 80 µl plain broth was added instead. The final concentrations of honey solution after inoculating bacteria in successive columns are shown in Table 4.1.

Table 4.1: The original concentrations of honey solutions used in each column, and the final concentration in each microplate well after serial dilution and inoculating cultures.

Original concentration:	50%	40%	30%	20%	10%
Well 1	16.60%	13.20%	9.90%	6.60%	3.33%
Well 2	13.30%	10.64%	7.98%	5.32%	2.66%
Well 3	10.65%	8.52%	6.39%	4.26%	2.13%
Well 4	8.50%	6.82%	5.12%	3.41%	1.70%
Well 5	6.80%	5.40%	4.05%	2.70%	1.36%
Well 6	5.45%	4.36%	3.27%	2.18%	1.09%
Well 7	4.35%	3.48%	2.61%	1.74%	0.87%
Well 8	3.49%	2.78%	2.09%	1.39%	0.70%
Well 9	2.79%	2.24%	1.68%	1.12%	0.56%
Well 10	2.23%	1.79%	1.34%	0.89%	0.45%

For anaerobes (*B. animalis* subsp. *lactis*, *Lactobacillus* spp. and *C. difficile*) a 10 times larger volume of broth in glass tubes was used instead of microplates. This macrodilution was for protecting the anaerobic cells from contact with the air during the process.

#### 4.2.6 MIC and MBC determination

The growth of non-fastidious organisms in the microplates was monitored at 37°C for 18 hours using a microplate reader (BMG FLUOStar OPTIMA) and the results were observed as the monitored growth curves. The microplate with the fastidious organisms *Campylobacter* spp. and *H. pylori* was incubated microaerobically at 37°C for 48 hours using the spirits burn method. The tubes with anaerobes were incubated anaerobically at 37°C for

18 hours using a gas pack system (MGC AnaeroPak™). The results of both microaerobes and anaerobes were observed visually at the end of incubation. The lowest concentration of honey needed to completely inhibit the growth of an microorganism in the 18 h period of incubation was defined as the minimum inhibitory concentration (MIC) of honey for the microorganism.

After the MIC determination, from each well or tube 10 µl was subcultured on appropriate agar plates without honey present to see if the various concentration of honey had been bacteriostatic or bactericidal for the tested organisms. The lowest concentration of honey the bacteria had been exposed to that completely inhibited the growth of the subcultured microorganism was considered to be the minimum bactericidal concentration (MBC). If the MIC was greater than 16.6%, which was the highest final concentration available in the MIC test, then subculturing was omitted as this suggested that the microorganism is relatively resistant to the honey and also that it would be of no practical importance to further investigate the MBC with a yet higher level honey. The broth cultures in the growth control wells were also subcultured on agar plate as positive controls. The susceptibility test for each species was replicated 5 times.

### 4.3 Statistical analysis

The difference between manuka honey M115 and the artificial honey for each species in results was analysed by the Wilcoxon test in the statistical package R (<http://www.r-project.org>) (R Development Core Team, 2008). Two-sided  $P < 0.05$  was considered statistically significant. Analysis was omitted for any species for which the MIC or the MBC was higher than 16.6%.

## 4.4 Results

### 4.4.1 *Facultative anaerobes*

All the facultative anaerobes had a lower MIC value with manuka honey M115 than with artificial honey (Table 4.2). Generally, manuka honey at a concentration less than 8% could inhibit the growth of the tested gastrointestinal bacteria. Although *Enterobacter* spp. had higher MICs than other tested microorganisms, the concentrations of manuka honey required to inhibit their growth were still lower than those of sugar syrup (approx. 11% cf >16%). The MBCs of manuka honey were generally higher than the MICs of the same honey by one or two dilution steps. The MIC and MBC of manuka honey M115 against the *P. aeruginosa* isolate were found to be relatively higher than those against other species of bacteria (approximately 16.6%).

### 4.4.2 *Microaerobes*

The results showing the sensitivity of *Campylobacter* spp. are shown in Table 4.3. The susceptibility test revealed that the growth of all 29 species of *Campylobacter* were strongly inhibited by manuka honey M113. The MIC of manuka honey for *Campylobacter* ranged from 0.8% to 1.1% whereas that of artificial honey was 3–4 times higher than that of manuka honey (3.1–4.3%), revealing that the MIC of manuka honey for each strain was significantly lower than that of artificial honey ( $P < 0.05$ ).

The MIC of manuka honey M115 for *H. pylori* was significantly lower than that for artificial honey ( $5.64 \pm 1.57$  cf.  $16.6 \pm 0$ ;  $P < 0.05$ ). Given that the potency of manuka honey M113 used for *Campylobacter* spp. was 1.78-time

Table 4.2: The minimum inhibitory and bactericidal concentrations (% v/v) of manuka honey M<sub>115</sub> and artificial honey for non-fastidious gastrointestinal pathogens. The values are represented as means of replicates  $\pm$  standard deviation. The determinations of the MIC and MBC values for each isolate were carried out after 18 h incubation, and were replicated 5 times. NT: not tested.

Species	MIC		MBC	
	Manuka	Artificial	Manuka	Artificial
<i>E. coli</i>	6.87 $\pm$ 0.97	> 16.6	7.48 $\pm$ 0.83	NT
<i>S. aureus</i>	3.74 $\pm$ 0.39	> 16.6	6.53 $\pm$ 0.54	NT
<i>P. aeruginosa</i>	15.94 $\pm$ 1.32	> 16.6	16.6 $\pm$ 0	NT
<i>Y. enterocolitica</i>	4.79 $\pm$ 0.54	> 16.6	5.45 $\pm$ 0	NT
<i>S. typhimurium</i> DT <sub>104</sub>	7.48 $\pm$ 0.83	> 16.6	10.65 $\pm$ 0	NT
<i>S. enteritidis</i>	6.8 $\pm$ 0	> 16.6	8.5 $\pm$ 0	NT
<i>E. aerogenes</i>	11.89 $\pm$ 2.15	> 16.6	16.6 $\pm$ 0	NT
<i>E. cloacae</i>	10.65 $\pm$ 0	> 16.6	16.6 $\pm$ 0	NT
<i>S. flexneri</i>	7.58 $\pm$ 1.14	> 16.6	8.5 $\pm$ 0	NT
<i>S. sonnei</i>	6.61 $\pm$ 0.47	> 16.6	8.5 $\pm$ 0	NT

(29.4/16.5) that of manuka honey M<sub>115</sub> which had been used for *H. pylori*, we may presume that the MIC of manuka honey M<sub>115</sub> for *Campylobacter* spp. would be about 1.42–1.96 %. It may consequently be presumed that the MIC of manuka honey with the same potency would be lower for *Campylobacter* spp. than for *H. pylori*.

The subculturing after determining the MIC showed that growth occurred when subculturing from concentrations of honey below the MIC whereas there was no growth from concentrations at and above the MIC. This revealed that the MIC of either manuka honey or artificial honey was also minimum bactericidal concentration (MBC) for *H. pylori* and for all of the *Campylobacter* spp. in this study.

Table 4.3: The minimum inhibitory concentration (% v/v) of manuka honey and artificial honey for microaerobes. *Campylobacter* and *H. pylori* were tested with manuka honey M113 (equivalent to 29.4% phenol) and M115 (equivalent to 16.5% phenol), respectively. The values are represented as means of the replicates  $\pm$  standard deviation. The determination of the MIC values for each isolate was carried out after 48 h incubation, and was replicated five times. The values of MBC were the same as those of MIC and were therefore not shown in this table.

Strains	Manuka honey	Artificial honey
<i>C. jejuni</i> 1	0.84 $\pm$ 0.08	3.13 $\pm$ 0.39
<i>C. jejuni</i> 2	1 $\pm$ 0.12	3.58 $\pm$ 0.38
<i>C. jejuni</i> 3	1 $\pm$ 0.12	3.44 $\pm$ 0.55
<i>C. jejuni</i> 4	0.8 $\pm$ 0.09	3.13 $\pm$ 0.39
<i>C. jejuni</i> 5	0.88 $\pm$ 0.14	3.58 $\pm$ 0.38
<i>C. jejuni</i> 6	1.05 $\pm$ 0.1	3.27 $\pm$ 0.32
<i>C. jejuni</i> 7	0.92 $\pm$ 0.17	3.75 $\pm$ 0.47
<i>C. jejuni</i> 8	0.96 $\pm$ 0.12	3.75 $\pm$ 0.47
<i>C. jejuni</i> 9	1 $\pm$ 0.12	3.92 $\pm$ 0.47
<i>C. jejuni</i> 10	0.8 $\pm$ 0.09	3.58 $\pm$ 0.38
<i>C. jejuni</i> 11	0.91 $\pm$ 0.1	3.58 $\pm$ 0.38
<i>C. jejuni</i> 12	1.05 $\pm$ 0.1	3.92 $\pm$ 0.47
<i>C. jejuni</i> 13	0.96 $\pm$ 0.12	3.92 $\pm$ 0.47
<i>C. jejuni</i> 14	0.88 $\pm$ 0.14	3.61 $\pm$ 0.66
<i>C. jejuni</i> 15	0.96 $\pm$ 0.12	3.75 $\pm$ 0.47
<i>C. jejuni</i> 16	1.05 $\pm$ 0.1	3.75 $\pm$ 0.47
<i>C. jejuni</i> 17	0.8 $\pm$ 0.09	3.92 $\pm$ 0.47
<i>C. jejuni</i> 18	1 $\pm$ 0.12	3.92 $\pm$ 0.47
<i>C. jejuni</i> 19	0.96 $\pm$ 0.12	3.58 $\pm$ 0.38
<i>C. jejuni</i> 20	0.92 $\pm$ 0.17	3.61 $\pm$ 0.66
<i>C. jejuni</i> ATCC 33560	1 $\pm$ 0.12	3.58 $\pm$ 0.38
<i>C. coli</i> 1	1.05 $\pm$ 0.1	4.09 $\pm$ 0.38
<i>C. coli</i> 2	1 $\pm$ 0.12	4.3 $\pm$ 0.68
<i>C. coli</i> 3	1.14 $\pm$ 0.12	4.09 $\pm$ 0.38
<i>C. coli</i> 4	1.1 $\pm$ 0.17	3.92 $\pm$ 0.47
<i>C. coli</i> 5	1.2 $\pm$ 0.15	3.92 $\pm$ 0.47
<i>C. coli</i> 6	1.14 $\pm$ 0.12	4.09 $\pm$ 0.38
<i>C. coli</i> 7	1.1 $\pm$ 0.17	3.92 $\pm$ 0.47
<i>C. coli</i> ATCC 33559	1.05 $\pm$ 0.1	4.09 $\pm$ 0.38
<i>C. fetus</i> ATCC 27374	0.96 $\pm$ 0.12	3.44 $\pm$ 0.55
<i>H. pylori</i> ATCC 43504	5.64 $\pm$ 1.57	16.6 $\pm$ 0
Mean of <i>C. jejuni</i> (n=21)	0.94 $\pm$ 0.08	3.63 $\pm$ 0.24
Mean of <i>C. coli</i> (n=8)	1.1 $\pm$ 0.06	4.05 $\pm$ 0.13

### 4.4.3 *Anaerobes*

The results showing the sensitivity of the anaerobes are listed in Table 4.4. The MIC of M113 manuka honey for *C. difficile* ranged between 2–3.6%, and the MBC between 4–5.4%. The *C. difficile* tested were much more resistant to artificial honey than natural honey, as can be seen from the high MIC (> 16.6%).

Table 4.4: The minimum inhibitory and bactericidal concentrations (% v/v) of manuka honey M113 and artificial honey for *C. difficile*. The values are represented as means of the replicates  $\pm$  standard deviation. The determinations of the MIC and MBC values for each isolate were carried out after 18 h incubation, and were replicated five times. NT: not tested.

Strains	MIC		MBC	
	Manuka	Artificial	Manuka	Artificial
<i>C. difficile</i> isolate 1	2.24 $\pm$ 1.28	> 16.6	5.15 $\pm$ 0.97	NT
<i>C. difficile</i> isolate 2	3.13 $\pm$ 0.78	> 16.6	5.41 $\pm$ 0.99	NT
<i>C. difficile</i> isolate 3	2.63 $\pm$ 0.81	> 16.6	4.23 $\pm$ 0.5	NT
<i>C. difficile</i> NCTC 11382	3.67 $\pm$ 0.43	> 16.6	4.91 $\pm$ 1.07	NT
<i>C. difficile</i> ATCC 9689	3.15 $\pm$ 0.87	> 16.6	4.72 $\pm$ 0.68	NT
<i>C. difficile</i> ATCC 43593	1.90 $\pm$ 0.69	> 16.6	4.66 $\pm$ 0.62	NT

### 4.4.4 *Probiotics*

The results for the sensitivity of the anaerobes to manuka honey M115 are shown in Table 4.5. The results revealed that these species are relatively tolerant to both manuka honey M115 and artificial honey. This is especially obvious in *B. animalis* subsp. *lactis* and *Lactobacillus* spp., for which there is no statistically significant difference in the MIC values between the two types of honey for each species ( $P > 0.05$ ).

The MBC of both manuka honey M<sub>115</sub> and artificial honey for all tested probiotics are very high. For all species a concentration of higher than 13.3% of manuka honey was required to kill the probiotics. Because higher than 16.6% of manuka honey M<sub>115</sub> seems to be required to kill *B. animalis* subsp. *lactis* and *Lactobacillus* spp., it was not possible to compare the MBC values of the manuka honey with those of artificial honey.

Table 4.5: The minimum inhibitory and bactericidal concentrations (% v/v) of manuka honey M<sub>115</sub> and artificial honey for the normal flora in the gastrointestinal tract. The values are represented as means of replicate  $\pm$  standard deviation. The determination of the MIC values for each isolate was carried out after 18 h incubation, and was replicated five times. NT: not tested.

Species	MIC		MBC	
	Manuka	Artificial	Manuka	Artificial
<i>E. faecalis</i> ATCC 19433	9.89 $\pm$ 1.9	> 16.6	16.6 $\pm$ 0	NT
<i>E. faecium</i> ATCC 19434	9.36 $\pm$ 1.05	> 16.6	13.3 $\pm$ 0	NT
<i>B. animalis</i> subsp. <i>lactis</i>	11.88 $\pm$ 4.9	14.7 $\pm$ 3.31	> 16.6%	> 16.6%
<i>L. plantarum</i> ATCC 8014	14.15 $\pm$ 3.62	16.6 $\pm$ 0	> 16.6%	> 16.6%
<i>L. rhamnosus</i> ATCC 7469	14.29 $\pm$ 2.67	16.6 $\pm$ 0	> 16.6%	> 16.6%

## 4.5 Discussion

Because some of the species in this work were done with double-potency manuka honey (M<sub>113</sub>; with non-peroxide antimicrobial activity equivalent to that of 29.4% phenol) whereas other species were done with manuka honey M<sub>115</sub> which is equivalent to 16.5% phenol, the MIC and MBC values obtained in this chapter cannot be compared directly. Despite this, it is possible to convert the mean MIC and MBC values for species tested with manuka honey M<sub>113</sub> by multiplying them by 1.78 (*i. e.* 29.4/16.5) so as to compare them with the MIC/MBC of manuka honey M<sub>115</sub>.



Overall the average concentration of manuka honey required to inhibit the growth of most organisms tested in this study was very low, which agrees with most other studies that tested or reviewed the efficacy of manuka honey against organisms with manuka honey (Al Somal et al., 1994; Cooper and Molan, 1999; Cooper et al., 2002a,b; French et al., 2005; Molan, 2006). The exceptionally high concentrations required to control *P. aeruginosa* are probably because of the biofilm, as has been widely known to be linked to its resistance against antimicrobial agents (Drenkard, 2003; Mah et al., 2003; Ryder et al., 2007).

Most publications only considered the MIC of the honey for microorganisms and rarely did they estimate the antibacterial property further. In this study the MIC and the MBC of the total activity of honey for some common gastrointestinal microorganisms were tested. The effectiveness of the non-peroxide antibacterial activity alone will be discussed in Chapter 5.

#### 4.5.1 *Facultative anaerobes*

Most facultative anaerobes tested were inhibited by the manuka honey with antimicrobial potency near the median level (equivalent to approx. 16% phenol) even when the honey was diluted 10-fold or more. On the other hand, the artificial honey which imitates the sugar content of a normal honey failed to inhibit the growth of all tested microorganisms even at the highest concentration used in the test (16.6%). This suggests that it is not the osmolarity but other antibacterial factors in the honey that are responsible for the inhibition of the growth of the bacteria.

In this susceptibility test, *S. typhimurium* DT104, a multi-antibiotic resistant strain of *Salmonella*, was included because the prevalence has been increasing for the last few years, and it is revealed that this strain can be inhibited by manuka honey at a concentration less than 10%. Although

antibiotic-resistant microorganisms are being increasingly reported and the number of resistant bacteria tested with honey is still limited so far, the efficacy of manuka honey against these seems promising. Prior studies have shown that honey is effective on MRSA and VRE (Cooper et al., 1999, 2002b; Natarajan et al., 2001).

Interestingly, bacteria with antibiotic-resistance properties were reported as soon as antibiotics were commonly used among the medical professions (Bennett and Parkes, 1944; Bondi and Dietz, 1945; Gallardo, 1945), whereas resistance to honey has not been reported regardless of it having been used as a medicine for millennia. The fact that bacteria have failed to develop resistance to honey is perhaps partially because the antibacterial efficacy of honey has not been widely known by medical professionals, and also partially because many of the reported antibacterial activities of honey being used had not been well standardised using a reference antiseptic. The result has been that a wide range of MIC values have been reported in the literature (in some cases these have ranged from less than 20% up to 100% for the same bacterial species; see Table 1.2), and consequently it is impossible to detect whether or not resistance to honey has developed.

Microorganisms are unlikely to acquire antibacterial resistance if they are treated with compounds targeting multiple loci (DeVito et al., 2002). As reviewed in Chapter 1, honey is a complex substance and the antibacterial activity is multi-factorial (Molan, 2009). Rose Cooper at University of Wales Institute has conducted a long-term study to select wound pathogens resistant to manuka honey by continuously exposing bacteria to a sub-lethal concentration of honey, but honey-resistant bacteria have not yet developed successfully (Cooper et al., 2009). A similar study conducted at Sydney University also failed to develop honey-resistant strains of *S. aureus* and *P. aeruginosa* whereas these bacteria had increased their resistancy to other antibacterial agents under similar condition in the study (Blair et al., 2009).

Although the number of antibacterial-resistant strains that have been tested with honey is relatively limited and whether or not bacteria would eventually develop resistance to honey was not evaluated in this study, the sensitivity of *S. typhimurium* DT104 to manuka honey in this study may partially, if not fully, suggest the usefulness of honey on treating multi-resistant strains of bacteria increasingly seen in medical disciplines.

#### 4.5.2 *Microaerobes*

Although the data obtained from this study cannot fully represent the profile of the genus *Campylobacter*, it is still obvious that the species tested are very susceptible to manuka honey regardless of their strains. The susceptibility test using manuka honey M113 gave a mean MIC value of 0.98% (standard deviation 0.15%) for the 30 *C.* strains (this includes 21 *C. jejuni*, 8 *C. coli* and 1 *C. fetus*).

The exceptionally low MIC for the artificial honey suggests that this microorganism may be highly susceptible to osmolarity. Doyle and Roman (1982) reported that *C. jejuni* could grow in brucella broth containing 1.5% of NaCl but failed in 2.0% NaCl or greater, and although large amount of *C. jejuni* ( $10^5$ – $10^6$  CFU/ml) may increase the tolerance in 6.5% salt at 4°C, the viable cells significantly decreased in 4.5% salt at room temperature. In that report Doyle showed that nalidixic acid-resistant thermophilic *Campylobacter* (NARTC) was generally tolerant to salt concentration, yet it still was unable to grow in the presence of 2.5% NaCl. Doyle and Roman (1982) also noted that a few strains would adapt to up to 6.5% NaCl after frequent subculturing and claimed that osmolarity might not be ideal for inhibiting the growth of *Campylobacter* spp. Interestingly, Reezal et al. (1998) noted that the osmotic effect on *Campylobacter* was seen regardless of whether the osmolyte in the medium was glucose or salts. Accordingly, the high

susceptibility of *Campylobacter* spp. to honey solutions observed in this study may be due in part to the osmotic effect of the sugar content as well as to other antimicrobial factors. However, given that the difference in the MIC of manuka honey and artificial honey were large ( $0.98 \pm 0.15$  cf.  $3.74 \pm 0.5$ ), the other antibacterial factors must also be largely contributing to the effectiveness of manuka honey.

The high susceptibility of *Campylobacter* spp. to osmolarity, however, may not be of practical consequence from an antimicrobial viewpoint. The concentration of sugar in the gut would decline rapidly down below the MIC through absorption across the mucosa and consequently may not inhibit the growth of *Campylobacter* spp. in the gut. Sugar is usually used for oral rehydration therapy or as immediate treatment for hypoglycaemia due to its rapid absorption through intestinal villi (Cuccurullo, 2004). Therefore dietary sugar is unlikely to contribute to the inhibition of campylobacteriosis.

On the other hand, although formerly named *Campylobacter pyloridis*, the susceptibility of *H. pylori* to honey appears to be quite different from *Campylobacter* spp. Although the manuka honey used with *H. pylori* had about half the antibacterial potency of that used with *Campylobacter* spp., the mean MIC value would be expected to decline by 1.78-times (*i. e.*  $3.17 \pm 0.88$ ) if the same honey as with the *Campylobacter* spp. work had been used. This calculated mean MIC value for *H. pylori* is still much higher than that for *Campylobacter* spp. As discussed above, *Campylobacter* seems to be highly sensitive to the osmotic effect, these being low MIC values even in artificial honey, whereas much higher concentration of artificial honey was required to inhibit *H. pylori*. Al Somal et al. (1994) tested the sensitivity of *H. pylori* to manuka honey (with non-peroxide activity equivalent to 13.2 % phenol) using an agar-well diffusion method with blood agar, and found that *H. pylori* can be inhibited with 5% manuka honey over 72 hours incubation. Ali et al. (1991) also reported that the growth of *H. pylori* may be prevented

with honeys from New Zealand and Saudi Arabia as well as carbohydrate solutions (glucose, fructose, and a mixture of these sugars in ratio of 1:1.23). In [Ali et al.](#)'s work, all carbohydrate solutions at a concentration of 15% or below were sufficient to inhibit all 28 clinical isolates of *H. pylori*. This suggests that besides the antibacterial component of honey, osmotic effect may be an important parameter for inhibiting or killing the species (albeit the effect may not be as significant as to *Campylobacter*).

There has been a clinical report which concern that manuka honey may not be useful for eradicating *H. pylori*. [McGovern et al. \(1999\)](#) treated 6 patients who had positive CLO tests (a rapid urease test to detect *H. pylori*) and <sup>14</sup>C urea breath tests with one tablespoon of manuka honey (with non-peroxide activity equivalent to 11.7% phenol), 4 times a day for 2 weeks, and another group of 6 patients was given honey and omeprazole twice a day for the same period. At the end of the two week trial both groups revealed positive <sup>14</sup>C urea breath test and the authors commented that the honey was ineffective at eradicating *H. pylori*. In this short report the authors did not state if the patients intook the honey before or after each meal. Although it seems that the [McGovern et al. \(1999\)](#) were following the suggestion in a magazine that "for ulcer relief ... eat a tablespoon of the honey spread on bread an hour before each meal", there has not been any scientific evidence suggesting that this would be a suitable dose for treating *H. pylori*, and also other factors may also have affected the result of the trial. In accordance with the susceptibility test in this study or with the prior study reported by [Al Somal et al. \(1994\)](#), 5% honey would be enough to prevent the growth of *H. pylori*.

Whilst the dose applied by [McGovern et al. \(1999\)](#) is somewhat controversial, the failure in the reported honey therapy could be explained by the biofilms. [Carron et al. \(2006\)](#) demonstrated biofilms in human gastric mucosa formed by *H. pylori* using a scanning electron microscope (SEM),

and suggested that this may be the cause why some *H. pylori* eradication therapies failed. Indeed, biofilms can protect bacteria from undesirable environmental factors like atmospheres and drugs, and it has been reported that a higher concentration of manuka honey than the MIC is required to eradicate the biofilms on the wound (Cooper and Jenkins, 2008). This is in agreement with the high MIC/MBC values for *P. aeruginosa* in Table 4.2 (both the MIC and MBC were approximately at 16.6%). Although in topical wound control, this can be overcome by consistently covering the wound with honey impregnated wound dressings or honey gels, this would not be feasible when honey is intaken orally. It must be emphasized that most susceptibility tests, including this project, were conducted under the condition of exposing the microbe to the honey for 72 hours, while any watery food like honey is unlikely to stay in the stomach for more than an hour. Therefore, further investigation on the relationship between manuka honey and the biofilms of *H. pylori* is required to evaluate the possibility of using the honey to eradicate *H. pylori* in the stomach, and at this stage people should not expect manuka honey to relief peptic ulcers or to eradicate *H. pylori* from the stomach from the reports based solely on the *in vitro* sensitivity tests.

It must also be noted that the result of the susceptibility of *H. pylori* to honey in this study definitely is not representative to all *H. pylori* due to the small sample size. It was attempted to collect several clinical isolates of *H. pylori* from Waikato hospital, NZ and then ESR, NZ but unfortunately this was not possible because it would take considerable effort to isolate and culture the species. Also, because of the difficulty on culturing *H. pylori* and *Campylobacter*, microaerobes were omitted from the studies in the following chapters.

### 4.5.3 *Clostridium difficile*

Although the sensitivity of *C. difficile* to manuka honey was determined with honey with high activity (M<sub>113</sub>), the MIC and MBC of honey with median activity (M<sub>115</sub>) for the anaerobes can be estimated to be about twice the MIC or MBC of that shown in Table 4.4. This would give MIC values between 4% and 7.5%, and MBC between 8% and 11%.

The sensitivity of *C. difficile* to antimicrobials including honey can be somewhat controversial because drugs can be effective against the bacterial cells but not the endospores. Although the *C. difficile* tested did not reveal resistance to manuka honey, the efficacy of honey against its endospore is unknown. In fact, even a high concentration of manuka honey is unlikely to be effective against bacterial endospores. Honey is stored aseptically in bee hives because of the enzymatic production of hydrogen peroxide during the ripening. When beekeepers collect honey from honey combs, the honey is exposed to the ambient environment and the outside of the honeycomb which may increase the chance it being contaminated by microbes (Cooper et al., 2009). Microbial contamination is of no concern in an undiluted honey because of the low  $a_w$  in which most microbes cannot survive. However, spores introduced into honey are not killed because spores can survive in high osmolarity, and although hydrogen peroxide is sporicidal at 0.88 M (Baldry, 1983), it is not produced until honey is diluted because the water activity is too low for glucose oxidase in honey to work. Even if honey is diluted so that the production of hydrogen peroxide is activated, the typical concentration (1 mM) is still far too low to kill spores (Molan, 1992a). Indeed, bacterial spores, particularly the *Bacillus* genus and *Clostridium botulinum*, are regularly found in honey (Snowdon and Cliver, 1996), and this is why honey is usually not recommended to be fed to infants. Although bacterial

spores in honey are unlikely to germinate, this indirectly indicates that honey may not be useful for eradicating the bacterial endospores in the gut.

Nonetheless, because it is viable bacterial cells but not spores that cause *C. difficile*-associated diarrhoea, the resistance of endospores to honey may not be of practical concern. In modern medicine, metronidazole or vancomycin has been used to treat severe *C. difficile*-associated diarrhoea but none of the drugs target the clostridial spores. Metronidazole is selectively taken up by anaerobe cells, reduced by indigenous enzymes, and the end product disrupts the DNA helical structure (Corey et al., 2007; Franklin and Snow, 2005). Vancomycin, on the other hand, acts by inhibiting proper biosynthesis of cell wall peptidoglycan in a Gram-positive anaerobe (Franklin and Snow, 2005). Clostridial bacteria or their spores could have existed in the gut of a host, but only when the clostridial cells germinate and outnumber other competitors in the gut can the species cause disease. It is possible that the antibacterial activity of manuka honey can be of some help to patients suffering from *C. difficile*-associated diarrhoea by suppressing the bacterial cells. Perhaps the capability of honey to stimulate the growth of probiotics may also indirectly help suppress the clostridia, although this hypothesis needs to be further investigated.

#### 4.5.4 Probiotics

Unlike most facultative anaerobes, microaerobes and *C. difficile* for which the MIC of the manuka honey with median-activity ranged between 4.5–8%, 2.5–6% and 4–7% respectively, all tested probiotics gave a relatively high MIC value (equivalent to or above 10%). Together with the even higher MBC values (>16%), this indicates that it is unlikely that manuka honey would kill the probiotics in the gut. Although the number of tested species



is limited, this suggests that probiotics might be relatively more tolerant to the honey than gastrointestinal pathogens.

The tolerance of anaerobic probiotics to manuka honey is unexpected. Honey, particularly manuka honey, is frequently reported to inhibit pathogens due to several mechanisms, among which hydrogen peroxide may be the major factor that decreases the growth of non-aerobes. Microaerobes and anaerobes do not tolerate the damage caused by reactive oxygen species because they produce no, or small amount of, catalase and superoxide dismutase. *B. animalis* subsp. *lactis* and *Lactobacilli* are considered to be anaerobes (Sneath and Holt, 1986) and, in theory, they should have revealed equivalent to or higher sensitivity than facultative anaerobes to honey. Although some probiotics have been known to produce hydrogen peroxide as a defence mechanism to compete against other microbiota in the gastrointestinal tract (Servin, 2004), which may indirectly indicate the relative tolerance of the probiotics of the peroxide activity of the honey, several other possible reasons can also be featured. Firstly, probiotics, especially *Bifidobacterium* spp., require glucose as their energy source (Sneath and Holt, 1986) and honey is rich in glucose. This may have compromised the damage the honey caused to the bacterial cells. However, MRS medium used for cultivating probiotics in this project contains 2% glucose that should be sufficient for the organisms ([http://service.merck.de/microbiology/tedisdata/prods/4973-1\\_10660\\_0500.html](http://service.merck.de/microbiology/tedisdata/prods/4973-1_10660_0500.html)), therefore lack of glucose in the medium for supporting their growth is unlikely. Secondly, some components such as galactooligosaccharide and fructooligosaccharide in honey may have functioned as prebiotics so that the growth of the probiotics was stimulated even in the existence of the antimicrobial activity of the honey, although further investigation is required to prove the hypothesis. Thirdly, the tested probiotic species may have some mechanisms that overcome, or at least tolerate, the antibacterial factors of manuka honey. As described

above, glucose (and hence osmolarity) is not inhibitive to the species. *Bifidobacterium* and *Lactobacillus* spp. are also known to be acidotolerant, which was used to design the selective MRS media for these species (it has a pH of 5.7; [de Man et al., 1960](#)), and this could have made the acidity of honey to be less inhibitive in probiotics. The effect of methylglyoxal in honey to probiotics as well as on other gastrointestinal bacteria is, unfortunately, not well known yet.

The sensitivity results for probiotics in this chapter is in agreement with recent research by [Rosendale et al. \(2008\)](#). [Rosendale et al.](#) studied the effect of several traditional medicines including manuka honey on probiotics (*L. rhamnosus*, *Lactobacillus reuteri* and *B. animalis* subsp. *lactis*) as well as enteropathogens (*E. coli*, *S. typhimurium* and *S. aureus*) by means of observing their growth turbidimetrically rather than determining the MIC. In that report [Rosendale et al. \(2008\)](#) denoted the activity of the manuka honey as “UMF20+” and did not state what percentage of phenol the non-peroxide activity was equivalent to. According to the unique manuka factor rating system, a manuka honey labelled UMF20+ means that honey has a non-peroxide antibacterial activity equivalent to equal to or greater than 20% phenol, which the activity is significantly higher than that of the manuka honey used in this thesis. Despite the high antibacterial activity being used, the group found that all probiotic growth increased while that of enteropathogens decreased. Interestingly, the same authors also noticed that some other traditional medicines (bee pollen, rosehip, blackcurrant oil and propolis) had either synergistic or antagonistic interactions on the effect of the honey on probiotics depending on the combination of the traditional medicines used. Although there has been very limited research on the effect of manuka honey on probiotics in the literature, this small project in this thesis as well as the work by [Rosendale et al. \(2008\)](#) suggest the possibility

of probiotics being more tolerant to manuka honey than enteropathogens are.

## 4.6 Conclusion

In short, most gastrointestinal bacteria are susceptible to the antimicrobial activity of manuka honey but not to artificial honey. The isolated *C. jejuni* and *C. coli* were found to be exceptionally sensitive to manuka honey. This may be partly due to their high sensitivity to osmotic action. Most tested organisms can be inhibited by manuka honey even if it is diluted 10–20 fold, and can also be killed with slightly higher concentration of the honey. Probiotics which we do not want to kill are found to be more tolerant to manuka honey than gastrointestinal pathogens are.

## THE EFFECT OF ATMOSPHERE

---

As part of the antibacterial activity of a honey is due to hydrogen peroxide, and because the oxygen is required to get glucose oxidase in a diluted honey solution to transform the glucose content to hydrogen peroxide and gluconic acid (Equation 1.1), it is possible that in the anaerobic gastrointestinal environment this reaction would be suppressed, which consequently could lead to a lower total antibacterial activity in manuka honey.

This chapter describes the study of the effect of gastrointestinal atmosphere on the overall and non-peroxide antimicrobial activities of manuka honey. The MIC and MBC of a normal manuka honey as well as the one treated with the enzyme catalase are compared in aerobiosis and anaerobiosis.

## 5.1 Introduction

As reviewed in Chapter 1, hydrogen peroxide is one of the major antibacterial factors in honey, and it is produced, slowly, only when honey is diluted (Equation 1.1). When humans ingest honey, ingested water and body secretions dilute the honey and consequently, in theory, hydrogen peroxide is produced in the gastrointestinal tract.

As shown in Equation 1.1, however, oxygen is also required to produce hydrogen peroxide and this may not be available in the gastrointestinal environment because that is generally anaerobic. It is in fact hard to predict whether there would be any effect on the antimicrobial activity of honey that is result from a less oxygenic environment such as in the gastrointestinal tract. Since oxygen is unavailable or limited in the tract, the actual antibacterial activity in honey could be at least impaired due to hydrogen peroxide being unable to be produced.

Environmental atmosphere, on the other hand, can also affect bacterial metabolism and consequently the growth of microorganisms which makes prediction more difficult. Facultative anaerobes can survive in both aerobic and anaerobic conditions by switching their metabolism (Yamamoto and Droffner, 1985), and because aerobic respiratory metabolism is more efficient than anaerobic fermentative metabolism, the growth of facultative anaerobes under anaerobic conditions is normally slower than that under aerobic conditions. As the mechanism of action of non-peroxide antibacterial substances in manuka honey remains to be understood, several possible scenarios were foreseen. Faster growth of a microorganism in an aerobic environment may lead it to overcome some levels of the negative effect caused by antibacterial substances in honey; in other words the cells may be more susceptible in anaerobiosis. The aerobic environment could also accelerate the metabolism of bacterial cells, which may therefore speed up

the bacterial cells' uptake (hence make it more sensitive) or efflux and/or metabolism (to detoxify) of extracellular antibacterial components. Yet, it is also possible that the shift in the overall effect is not significant due to the overall uptake and efflux being balanced in the cells.

In a preliminary test, an agar well diffusion trial using some facultative anaerobes was conducted to study the effect of anaerobic incubation on the activity of honey. It was intended to compare the inhibition zones seen on nutrient agar plates in aerobic, microaerobic and anaerobic conditions. However, in this preliminary test, inhibition zones were seen only in aerobic and microaerobic conditions. In contrast, a relatively opaque zone instead of an inhibition zone was seen in the anaerobic condition (Figure 5.1). As the observed opaque zone around the well was denser than the background, it was thought that the dense zone was an indicative sign of the stimulative effect of honey on the growth of the seeded bacteria. The reason why the antibacterial activity in honey did not take effect in the anaerobic condition in this preliminary test is not clear. Although there would have been no ongoing production of hydrogen peroxide in GasPak canister, non-peroxide antibacterial substances should have taken over the antimicrobial action. In the anaerobic incubation the growth of the tested facultative anaerobe was significantly slower than those in aerobic or microaerobic conditions, which could be observed from the size of the colonies impregnated in the agars. Perhaps the antibacterial substances in the honey had diffused out of the well so that the concentration had been diluted down below the MIC before the substances could inhibit the slow-growing bacteria. Also at the same time, sugar or other components in honey could have helped the bacterial cells to overcome the undesirable environmental stresses (peroxide/non-peroxide activity from honey and low oxygen level in this preliminary test).

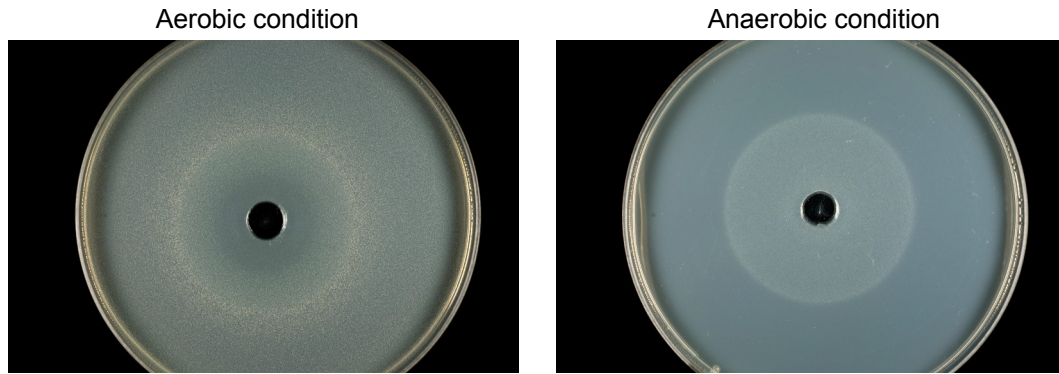

Figure 5.1: The comparison of the result of agar diffusion assay in the aerobic and anaerobic (GasPak) conditions. In the photographs nutrient agar plates seeded with *S. typhimurium* DT104 (approx.  $10^5$  cfu/ml in the agar) were incubated at  $37^\circ\text{C}$  overnight. In each well 100  $\mu\text{l}$  of 25% manuka honey M115 solution was loaded.

Because this informal preliminary test had suggested that the agar well diffusion technique may be not be suitable for evaluating the effect of environmental atmosphere on the antibacterial activity in honey, in the work in this chapter the MIC/MBC values were obtained using the broth microdilution method instead.

## 5.2 Materials and method

Facultative anaerobic gastrointestinal bacteria chosen from Table 2.1 were used for testing the effect of atmosphere on the antibacterial activity of the honey because these microorganisms were able to grow in a wide range of atmospheres. The ones used were: *E. coli*, *Salmonella*, *Enterobacter*, *Enterococcus*, *Yersinia* and *Shigella*. All organisms were cultured in MHB. Culture, handling and inoculum preparation were conducted as described previously in Section 4.2.

Manuka honey sample M115, which has an antimicrobial activity equivalent to 16.5% phenol, was used. An artificial honey (AH) which is a sugar

syrup was used as a control to find if osmolarity was the factor that was inhibiting the growth of the tested bacteria.

To investigate the effect of hydrogen peroxide activity in manuka honey on the facultative anaerobes, manuka honey solution containing 0.1% (w/v) catalase was also included in the test. A solution of 0.2% w/v catalase solution was made by adding 0.02 g of catalase in 10 ml of distilled water and then this was filtered through a 0.22  $\mu\text{m}$  filtre membrane. The same amount of the 0.2% w/v catalase stock solution and double-strength honey were mixed so that there was 0.1% catalase in the final honey solution. The amount of catalase used was enough to eliminate any hydrogen peroxide activity in the honey (Allen et al., 1991a). This solution of manuka honey with catalase was treated in the same way as that without catalase, and had the same final concentrations as those without catalase in the microplate after serial dilution and inoculation (Section 4.2.5). As the MIC/MBC of manuka honey and artificial honey in aerobic conditions had been measured in Chapter 4, the MIC/MBC values from Chapter 4 were integrated in the results in this chapter (Table 5.1 and 5.2).

To compare the effect of different atmospheres on the MIC/MBC of the honey, the susceptibility test was undertaken in aerobic and anaerobic atmospheres simultaneously. The anaerobic condition was generated with a gaspack system (MGC AnaeroPak<sup>TM</sup>). All cultures were incubated at 37°C overnight.

The MIC of the honeys under anaerobic conditions was observed visually because it was impossible to do this using the microplate reader. Other than this, the processes of the MIC/MBC evaluation were the same as those described in Section 4.2.6. The MIC/MBC of manuka honey for the species were compared between the two atmospheres using two-way ANOVA in R statistical package (R Development Core Team, 2008).



### 5.3 Results and discussion

In this chapter, the effect of atmospheric condition (anaerobic environment) on the antibacterial activity of manuka honey was studied to evaluate the likely efficacy of the honey on the pathogens in the gastrointestinal tract. The values formed for the MIC and MBC of honey in aerobic and anaerobic conditions are shown in Tables 5.1 and 5.2. For comparison, data from Chapter 4 are also integrated in these tables. As far as the author is aware, this is the first study that looks at the alteration of the effectiveness of manuka honey in an oxygen-limited environment. Many clinically important gastrointestinal pathogens have been extensively studied in aerobic conditions (Cooper et al., 2009; Molan, 2009), but no consideration on the efficacy against the facultative anaerobes in a low oxygen concentration has been given. In fact, during the study we noticed that in all of the treatments, bacterial growth under anaerobic conditions was much slower than under aerobic conditions as can be observed visually from the size of the pellet of bacteria settled at the bottom of the microplate wells, suggesting the possibility that the anaerobic atmosphere could indeed alter the cells' morphology and therefore the actual sensitivity to an antimicrobial.

Table 5.1 allows the MIC of honeys in aerobic and anaerobic conditions to be compared. ANOVA reveals that overall both atmosphere and honey type significantly effect the MIC ( $P < 0.05$ ) for each. The MIC values for manuka honey in anaerobic condition appeared to be equivalent to or lower than those in aerobic condition, and the degree of difference varied depending on the species (varied from less than 1% to more than 4%). This suggests that bacteria are slightly more susceptible to the total activity of manuka honey under anaerobic conditions, with *E. faecalis* being an exception which had a numerically but not statistically higher MIC in anaerobic condition.

Table 5.1: The results of the effect of atmosphere on the MIC (% v/v) of manuka honey, manuka honey plus catalase, and artificial honey. The values are represented as means of replicate  $\pm$  standard deviation. The results for aerobic work are copied from Table 4.2 and 4.5. The determination of the values for each isolate was repeated 5 times. DNG: The culture did not grow. \*: significantly different for each species for aerobic vs. anaerobic conditions for each treatment ( $P < 0.05$ ).

Species	Atmospheres	MIC		
		Manuka	Manuka+catalase	Artificial
<i>E. coli</i>	Aerobic	6.87 $\pm$ 0.97	7.48 $\pm$ 0.83	> 16.6
	Anaerobic	6.8 $\pm$ 0	6.8 $\pm$ 0	> 16.6
<i>P. aeruginosa</i>	Aerobic	15.94 $\pm$ 1.32*	16.6 $\pm$ 0*	> 16.6
	Anaerobic	DNG	DNG	DNG
<i>Y. enterocolitica</i>	Aerobic	4.79 $\pm$ 0.54*	7.48 $\pm$ 0.83	16.6
	Anaerobic	3.49 $\pm$ 0	6.8 $\pm$ 0	16.6
<i>S. typhimurium</i> DT104	Aerobic	7.48 $\pm$ 0.83	7.48 $\pm$ 0.83	> 16.6
	Anaerobic	6.53 $\pm$ 0.54	6.8 $\pm$ 0	> 16.6
<i>S. enteritidis</i>	Aerobic	6.8 $\pm$ 0	6.8 $\pm$ 0	> 16.6
	Anaerobic	6.8 $\pm$ 0	6.8 $\pm$ 0	> 16.6
<i>E. faecalis</i>	Aerobic	9.89 $\pm$ 1.9	8.93 $\pm$ 0.86	> 16.6
	Anaerobic	10.65 $\pm$ 0	10.22 $\pm$ 0.86	> 16.6
<i>E. faecium</i>	Aerobic	9.36 $\pm$ 1.05	8.5 $\pm$ 0	> 16.6
	Anaerobic	8.16 $\pm$ 0.68	6.8 $\pm$ 0	> 16.6
<i>E. aerogenes</i>	Aerobic	11.89 $\pm$ 2.15*	16.66 $\pm$ 0	> 16.6
	Anaerobic	7.48 $\pm$ 0.83	16.66 $\pm$ 0	> 16.6
<i>E. cloacae</i>	Aerobic	10.65 $\pm$ 0*	15.99 $\pm$ 1.34*	> 16.6
	Anaerobic	5.72 $\pm$ 0.54	13.3 $\pm$ 0	> 16.6
<i>S. flexneri</i>	Aerobic	7.58 $\pm$ 1.14*	9.36 $\pm$ 1.05*	> 16.6
	Anaerobic	2.93 $\pm$ 0.28	6.8 $\pm$ 0	> 16.6
<i>S. sonnei</i>	Aerobic	6.61 $\pm$ 0.47*	8.93 $\pm$ 0.86*	> 16.6
	Anaerobic	2.34 $\pm$ 0.23	6.8 $\pm$ 0	> 16.6

Table 5.2: The results of the effect of atmosphere on the MBC (% v/v) of manuka honey, manuka honey plus catalase, and artificial honey. The values are represented as means of replicate  $\pm$  standard deviation. The results for aerobic work are copied from Table 4.2 and 4.5. The determination of the values for each isolate was repeated 5 times. NT: Not tested. \*: significantly different for each species for aerobic vs. anaerobic conditions for each treatment ( $P < 0.05$ ).

Species	Atmospheres	MBC		
		Manuka	Manuka+catalase	Artificial
<i>E. coli</i>	Aerobic	7.48 $\pm$ 0.83	8.5 $\pm$ 0	NT
	Anaerobic	8.5 $\pm$ 0*	14.62 $\pm$ 1.62*	NT
<i>P. aeruginosa</i>	Aerobic	16.6 $\pm$ 0	> 16.6	NT
	Anaerobic	> 16.6	> 16.6	> 16.6
<i>Y. enterocolitica</i>	Aerobic	5.45 $\pm$ 0	8.5 $\pm$ 0	> 16.6
	Anaerobic	6.8 $\pm$ 0*	10.22 $\pm$ 0.86*	> 16.6
<i>S. typhimurium</i> DT <sub>104</sub>	Aerobic	10.65 $\pm$ 0	16.6 $\pm$ 0	NT
	Anaerobic	10.65 $\pm$ 0	16.6 $\pm$ 0	NT
<i>S. enteritidis</i>	Aerobic	8.5 $\pm$ 0	16.6 $\pm$ 0	NT
	Anaerobic	13.3 $\pm$ 0*	16.6 $\pm$ 0	NT
<i>E. faecalis</i>	Aerobic	16.6 $\pm$ 0	13.3 $\pm$ 0	NT
	Anaerobic	15.94 $\pm$ 1.32	15.94 $\pm$ 1.32*	NT
<i>E. faecium</i>	Aerobic	13.3 $\pm$ 0*	13.96 $\pm$ 1.32*	NT
	Anaerobic	9.79 $\pm$ 1.05	10.65 $\pm$ 0	NT
<i>E. aerogenes</i>	Aerobic	16.6 $\pm$ 0	16.6 $\pm$ 0	NT
	Anaerobic	> 16.6	> 16.6	NT
<i>E. cloacae</i>	Aerobic	16.6 $\pm$ 0*	16.6 $\pm$ 0	NT
	Anaerobic	8.5 $\pm$ 0	> 16.6	NT
<i>S. flexneri</i>	Aerobic	8.5 $\pm$ 0*	16.6 $\pm$ 0	NT
	Anaerobic	5.45 $\pm$ 0	16.6 $\pm$ 0	NT
<i>S. sonnei</i>	Aerobic	8.5 $\pm$ 0*	10.65 $\pm$ 0	NT
	Anaerobic	3.66 $\pm$ 0.34	9.36 $\pm$ 1.05	NT

To investigate the effectiveness of the non-peroxide activity in manuka honey, the enzyme catalase was added into the manuka honey to remove any activity due to hydrogen peroxide. The MIC results show that bacteria have a slightly higher sensitivity to the non-peroxide activity under anaerobic conditions, a similar trend that has been previously shown in the total antibacterial activity under anaerobic conditions. The non-peroxide antibacterial activity in manuka honey has now been identified as being due to methylglyoxal (Adams et al., 2008; Mavric et al., 2008), and the MIC may represent the effectiveness of methylglyoxal. However, it is noteworthy that methylglyoxal may combine with the N-terminal segment of proteins (Inoue and Kimura, 1995) that generally exist in a medium and that may result in extra amounts of methylglyoxal being required to interact with bacteria. Therefore, it may be questionable to regard this as the “MIC for methylglyoxal”.

No inhibition on the tested microbes was observed in artificial honey in both atmospheric environments (all MIC values were  $\geq 16.6\%$ ). This indicates that the osmolarity of honey would not practically inhibit bacteria both in intestinal or external conditions. Although there would be some difference in the actual MIC values if the range of honey concentrations tested had been wider, that still would not be of very much practical importance because the concentration of sugar in the gut is unlikely to reach a high level.

Some interesting aspects can be seen when the sensitivity of each bacterial species to the bacteriostatic activity of manuka honey with and without hydrogen peroxide removed are compared. For some species (*E. coli*, *P. aeruginosa* and *Salmonella*) the honey with catalase added revealed equivalent or marginally higher MIC than a normal manuka honey ( $P > 0.05$ ), whereas for some other species (*Yersinia*, *Enterobacter* and *Shigella*) a much higher concentration of the manuka honey with catalase was required to inhibit their growth ( $P < 0.05$ ). Unexpectedly, *E. faecalis* and *E. faecium*

were found to be slightly more sensitive to manuka honey with catalase than without catalase, although this is numerically but not statistically different ( $P > 0.05$ ). Perhaps this numerical increase in the sensitivity result of *Enterococcus* spp. is simply because of the limited number of the species being examined. Alternatively, it may be that the catalase used is toxic to the bacteria. More species samples would be needed to ascertain this phenomenon.

On the other hand, the bactericidal profile of manuka honey appeared to be largely different from what has been described above for the MIC values, as the atmosphere factor appears to account less for the effect on the MBC ( $P > 0.1$ ). More species (*E. coli*, *P. aeruginosa*, *Yersinia*, *S. enteritidis* and *E. aerogenes*) gave higher MBC values with normal manuka honey in anaerobic than in aerobic condition ( $P < 0.05$ ), whereas equivalent or lower MBC values were seen in *S. typhimurium* DT104 and *E. faecalis* ( $P > 0.05$ ), and significantly lower in *E. faecium*, *E. cloacae* and *Shigella* ( $P < 0.05$ ). This was same for the MBC values of manuka honey with catalase except *E. faecalis* (significantly higher MBC value in anaerobic condition;  $P < 0.05$ ) and *E. cloacae* (numerically higher MBC value in anaerobic condition;  $P > 0.05$ ).

The MBC values for manuka honey with catalase had yet higher values than for those without catalase for all atmospheric conditions. Again, *E. faecalis* in air was the only exception (significantly lower in aerobic condition;  $P < 0.05$ ). Some of the tested microorganisms were marginally more resistant to the bactericidal effect of the non-peroxide activity in the honey (*E. coli* in air and *E. faecium* in both atmospheres;  $P > 0.05$ ), but for most species (*E. coli* and *E. cloacae* in anaerobic, *Yersinia*, *Salmonella* and *Shigella*) a much higher concentration of honey was required to kill the cells when hydrogen peroxide had been removed ( $P < 0.05$ ).

Although *P. aeruginosa* is usually considered an aerobe, and in the MIC test this species indeed did not show any growth in anaerobic condition,

after subculturing on an agar plate in the air *P. aeruginosa* was found to be still surviving as shown in the MBC data (Table 5.2).

Some species of bacteria showed equivalent sensitivity to manuka honey with or without hydrogen peroxide present, whereas others showed up to 4 times higher MIC values if catalase was added in the honey. This suggests that the non-peroxide antibacterial factors contribute most of the antibacterial activity of manuka honey because otherwise the activity should have been eliminated by enzyme catalase and should have given high MIC values similar to those with artificial honey. Although *Enterobacter* spp. appeared to be relatively tolerant to the non-peroxide activity, they still were more sensitive than to artificial honey, which suggest that the activity can still be useful to inhibit these species. The MBC test, on the other hand, suggests that the non-peroxide activity of manuka honey has a relatively “mild” effect on bacterial cells. It can be seen in Tables 5.1 and 5.2 that the MBC of the total activity of manuka honey was higher than the MIC and, with some species, catalase appears to destroy the activity much further. If the MBC of manuka honey with and without catalase is compared, it is clear that to some species the concentration of the non-peroxide activity required to kill the cells is more than twice of that of the total activity. The increase in the MIC and MBC values indicates that hydrogen peroxide actually plays a role in manuka honey to inhibit bacteria, and this effect seems to be more significant with some species of bacteria. Manuka honey is usually mistakenly called “non-peroxide honey” in literature for the public, whereas Tables 5.1 and 5.2 indicates that manuka honey in fact can have both peroxide and non-peroxide activities, although some species appear to be less sensitive to the hydrogen peroxide in the honey.

Although the difference in the MIC/MBC between different atmospheric environments could have been because of enzyme glucose oxidase in honey was unable to convert glucose into hydrogen peroxide in the absence of

oxygen, the anaerobic environment might have also caused environmental stress to the facultative anaerobes which may lead to some morphological adaptations in the cells.

To inhabit in virtually every area in the world, prokaryotes have had to develop appropriate mechanisms to survive or thrive under a wide variety of conditions. Not only do they need to be able to inhabit some specific environments (*e.g.* hyperthermophiles, halophilic/acid-tolerant bacteria), but they also need to be able to adjust to sometimes prolonged extreme conditions. The air can actually be considered an extreme condition because without an appropriate amount of protective enzymes (catalase and superoxide dismutase) cells would be damaged by oxidative stress caused by ROS (Iuchi and Weiner, 1996). Many bacterial stress responses have been found to be genetically regulated. When bacteria transit from an aerobic environment to one that is anaerobic (for instance, when gastrointestinal pathogens enter the gastrointestinal tract), there would be a change in genetic expression which is regulated by the fumarate and nitrate reduction (FNR) regulatory protein (Barton, 2005). FNR is in a dimer form and binds stably to DNA in an anaerobic environment and, in an aerobic condition (with 1–10  $\mu\text{M}$  oxygen) the structure turns into monomers and decreases in the ability to bind DNA. With the FNR regulation system, organisms in an anaerobic environment can reduce the production of enzymes involved in aerobic metabolism and increase that required for anaerobic respiration.

Atmospheric factors have been reported to significantly affect certain antibiotics. Rosenblatt and Schoenknecht (1972) reported that gentamicin, streptomycin, kanamycin and erythromycin were less active in an anaerobic condition whereas tetracycline and chloramphenicol revealed higher activities against *E. coli*. Goldstein and Sutter (1983) noted that active erythromycin deteriorated by more than 50% after 18 hours incubation in  $\text{CO}_2$ .

Environment atmospheric stress may also result in the modification of the morphology of bacterial cells which consequently alters the sensitivity to antimicrobials. *P. aeruginosa*, either in planktonic or in biofilm forms, appeared to be more resistant to antibiotics if oxygen was limited (Field et al., 2005), whereas anaerobically grown *E. coli* K-12 was reported to fail in biofilm formation (Colón-González et al., 2004). Likewise, it is possible that the FNR or other gene regulations regarding environmental stress response may affect the sensitivity of bacterial cells to antibiotics or antibacterials such as hydrogen peroxide or methylglyoxal in honey. This, together with the response to other stresses such as pH and enzymes (that are discussed in Chapter 7), will be discussed in Chapter 8.



## THE PHARMACODYNAMICS OF MANUKA HONEY

---

In this chapter the pharmacodynamics of the antibacterial activity of manuka honey is described. The hypotheses are: that the pharmacodynamics of manuka honey are like those of conventional antimicrobial agents; that the number of viable organisms continuously exposed to a constant concentration of manuka honey declines as exposure time passes; and that after bacterial cells have been exposed to manuka honey for a short period the antimicrobial effect of manuka honey persists for a while even after the removal of the honey.

In the first part, the time-to-kill test that evaluates the time required to eliminate bacterial cultures persistently exposed in a constant level of manuka honey was investigated. The second part of this study investigated the postantibiotic effect of manuka honey in which bacterial cells were exposed to the honey temporarily and the survival of the treated cells after that was monitored.

## 6.1 Introduction

Antimicrobial agents are capable of inhibiting or killing organisms if their concentrations are above the MIC or MBC, and this has widely been used for evaluating the efficacy of drugs. The principle of the MIC test is to expose the targeted micro-organisms to an antibacterial agent of interest at a series of concentrations of antibacterial agents for a pre-defined time (usually overnight) and monitor the growth of the organisms. The minimum concentration which inhibits the growth of the organisms is then recorded as the MIC. Similarly, the minimum concentration of the antimicrobial agents that is required to kill the tested organisms is termed the MBC. This is usually approached by subculturing the broth media from the MIC test to a fresh solid medium on which microbes may still be alive.

In the MIC test the concentrations of antibacterial agent remain at a high or constant level through the assay. However, this is clearly not feasible *in vivo* for several reasons.

On some occasion *in vivo* it is desirable for an antimicrobial agent to take effect on the bacterial cells in a short time because the actual exposure time of the cells to the active ingredient may actually be much shorter than is the case when the MIC test is conducted *in vitro*. A significant example is the usage of antibiotics in ophthalmology. As eyedrops are usually washed off within minutes after being applied on the infected eyes, the bacteriostatic and bactericidal information obtained from the MIC/MBC tests alone are not useful for evaluating the efficacy of antimicrobial agents in treating such cases. Several efficacy assays of the antibiotics used for *H. pylori* eradication have been criticised to be inadequate because they fail to control the viability of the organisms within 3 hours (Irie et al., 1997). Similarly, MIC/MBC values usually do not account for the significantly fluctuating drug concentration within a body as time passes due to various factors in

the host. The active amount of antimicrobial agents may decline, as can be seen on the degradation of penicillins, cephalosporins, cephamycins, ertapenems and carbapenems by ESBL (extended spectrum  $\beta$ -lactamase) secreted by Gram-negative bacteria such as *E. coli*, *Klebsiella pneumoniae*, *Proteus mirabilis*, *P. aeruginosa* and some *Enterobacteriaceae* (Bradford, 2001; Jones, 2001; Paterson and Bonomo, 2005). The active ingredient may also be substantially diluted by large amount of body fluid or exudate, and therefore the total concentration eventually goes below the MBC or even MIC. Alternatively the active ingredient may be excreted out of the body through the urinary system (Kasper et al., 2005) before it has time to be of effect on bacteria. Therefore the efficacy of antibacterial agents in treating infections may not be as good as that indicated from *in vitro* susceptibility tests.

The situation described above is not limited to chemical antibiotics but is applicable to honey too. The efficacy of honey is generally considered to be lower than that of antibiotics, which also means the concentration required to suppress the growth of bacteria is higher than that of antibiotics (approx. 100 mg/ml cf.  $\mu$ g/ml). In wound treatment the active component in honey would diffuse into the wound from the dressing, and eventually the active concentration would decline to that below the MIC to the pathogens on the wound. Likewise, honey intaken orally would be greatly affected by dilution by large amounts of body fluid *e.g.* saliva, gastric juice and intestinal fluid and water from food and drink. A short transit time due to rapid peristalsis in the gastrointestinal tract may also result in a short period of contact with bacterial cells. Although it is unknown how much of the antibacterial activity of honey exactly would be able to reach the stomach or the lower intestine so as to inhibit gastrointestinal pathogens, it is very clear that the achievable concentration would be much lower than the initial concentration taken in. To evaluate the antibacterial efficacy of honey on

bacteria in such conditions, several pharmaceutical parameters other than the conventional sensitivity test are required.

In pharmacology several parameters, namely pharmacokinetics and pharmacodynamics (PK/PD), are used to evaluate dynamically the efficacy of a drug (Dalhoff, 1997). Pharmacokinetics in antibiotic research monitors the fluctuation of the concentration of the antibiotic after delivery into a living host (Dalhoff, 1997). As the drug concentration during the treatment can be affected greatly by biological metabolism *e.g.* preantibiotic, the pharmacokinetics evaluation is usually approached by quantitatively analysing the parent drug and its metabolites using chromatographic systems and producing serum concentration versus time curves (Dalhoff, 1997). Pharmacokinetics, however, is not always possible because this parameter involves monitoring the level of the known substances, and evaluating the pharmacokinetics of a complex substance of unknown composition such as manuka honey is not feasible.

Pharmacodynamics, on the other hand, is used in antibiotic research for predicting the eradication of bacteria by an antibacterial agent. It describes the exact effect of an antimicrobial substance on bacterial cells and thus is increasingly used for evaluating the mode of action of antibacterial agents (Jacobs, 2003) and for predicting bacterial eradication. Several suggested pharmacodynamics parameters include, but are not limited to, the area under the plasma concentration-time curve (AUC), the drug's peak concentration ( $C_{\max}$ ), and the time the drug concentration exceeds the MIC ( $T > \text{MIC}$ ) (Nicolau, 2003). The effectiveness of a number of antibiotics has been well predicted by these models (Nicolau, 2003).

The postantibiotic effect (PAE) is one of the pharmacodynamics parameters. It describes the persistent suppression of bacterial growth after a short exposure of bacteria to antibacterial agents (Craig and Gudmundsson, 1996). This was first systematically observed by Parker and Marsh (1946)

who noticed that after staphylococci had been exposed to penicillin, the organisms did not resume multiplying immediately after the removal of the drug but instead remained constant in number for a while, before beginning to multiply again at their normal rate. The duration of the lag seems to depend on individual bacterial species or even strains, the concentration of the drug and the time for which bacteria have been exposed to the drug. [Eagle and Musselman \(1949\)](#) tested several cocci including  $\alpha$ - and  $\beta$ -haemolytic streptococci, staphylococci, pneumococci and enterococci with penicillin, and noticed that the persistent effect of the drug reached a maximum level at the concentration that was most rapidly bactericidal for the organism. In this study the authors also found that beyond the maximum effect, the persistence of effect did not increase further even with a 10 000-fold increase in the level of the drug. Similarly, the persistence reached its maximum within one to two hours of exposure time, and even 24 hours of exposure did not significantly prolong the period of persistence. Interestingly, for some strains the duration of persistence increased directly as the preceding exposure time to penicillin increased ([Eagle, 1949](#)). [Eagle](#) noticed that once a bacterium had been treated with a large enough amount of antibiotic even for a short time, the cells were 'bombarded' so that the microorganism required extra time to recover from the damage, and meanwhile the cells would not replicate until they had completely recovered from the damage, regardless of the absence of antibiotics. In other words, antimicrobial agents may not need to be present continuously during treatment of infections. Indeed, this is one of the main principles when estimating the interval required between dosages of a drug ([Odenholt, 2001](#)). A thorough review of the persistent effect of antimicrobial agents has been published by [Craig and Gudmundsson \(1996\)](#).

The principle of assaying the postantibiotic effect is to compare the time required for bacteria treated within an antibacterial agent and for un-

treated control bacteria to reach the same growth speed as each other. This is generally done by exposing bacteria to a medium containing an antimicrobial agent for a short term (normally 1–2 hours), followed by removing the antibacterial agent by means of centrifugation, dilution, inactivation or membrane filtration (Craig and Gudmundsson, 1996). The bacterial cells are then incubated in a fresh medium without the antibacterial agent and the growth curve is observed. It must be noted that because the PK/PD parameters may vary greatly among bacterial species, and also that because they may not be directly relevant to the MIC/MBC (Irie et al., 1997), it is unlikely that PK/PD parameters can be predicted with the usual susceptibility tests.

Although honey has been proven to have substantial antimicrobial activity even against the organisms that modern antibiotics fail to eradicate (Molan, 2009), this has mostly been demonstrated with conventional susceptibility tests or with observations during clinical trials. And despite the large number of published reports showing the significant antimicrobial activity and efficacy of the honey, it is not known at all whether or not the honey would reveal any of the PK/PD parameters against microbes. This may be partially because honey is a complex mixture of carbohydrates, and it is unlikely to approach a pharmacokinetics study without knowing the exact antimicrobial substance. Also, there has been comparatively little interest in the PK/PD properties even of modern antibiotics until recently. Therefore it is important to study the pharmacodynamics of the antimicrobial activity of honey, so as to evaluate the utility of manuka honey for internal use. This information would also be of help for the medical professionals to understand the usefulness of honey if the pharmaceutical properties of honey could be studied in further details.

Therefore in this study it was intended to first investigate how long it would take manuka honey to eliminate micro-organisms, and to investigate if honey would have the postantibiotic effect that other common drugs do,

so that a 'honey-exposed' microorganism would still be inhibited even if the honey gets diluted to a low level afterwards.

## 6.2 Materials

From the work in Chapter 5, it was clear that the concentration of artificial honey required to inhibit organisms was much higher than that of manuka honey. Therefore only manuka honey (M115) was used in this pharmacodynamics assay.

### 6.2.1 *Bacterial strains*

*Salmonella*, *Shigella*, *Enterobacter*, *P. aeruginosa*, *Enterococcus*, *E. coli*, *Y. enterocolitica*, *B. animalis* subsp. *lactis* and *Lactobacillus* were used in the pharmacodynamics tests. *H. pylori*, *Campylobacter* and *C. difficile* were not tested in this study due to the difficulty of culturing them. *B. animalis* subsp. *lactis* and *Lactobacillus* were omitted in the time-to-kill test because according to the MBC test in Chapter 4, it is clear that a high level of manuka honey (16%) cannot kill these species even after 18 hours of persistent incubation.

Culture handling and inoculum preparation were as described previously in Chapter 5 except that the optically adjusted broth culture was diluted 30 times instead of 300 times so that the final concentration would be approximately  $3 \times 10^6$  cfu/ml which was 10 times as concentrated as that had been used in the work in other chapters. This was used as the inoculum.

### 6.2.2 *Culture media*

Mueller-Hinton broth (MHB) was used for cultivating most organisms as described earlier. Man-Rogosa-Sharpe medium (MRS) was used for cultivating *B. animalis* subsp. *lactis* and *Lactobacillus* spp. as described earlier. These broths were also used for washing honey off from bacterial cells. Double-strength broths were used for preparing honey solutions. Solid media in square agar plates (100×100×20 mm) and in regular Petri dishes were used for the viable cell counting.

### 6.2.3 *Diluent broth for serial dilution*

Broth (MHB for most organisms; MRS for *Bifidobacterium* and *Lactobacillus*) was aseptically dispensed in sterile bijou bottles to make 0.9 ml in each. The lids were tightened so that the broth would not evaporate during storage. These dispensed broth in bijou bottles were for serially diluting bacterial solutions during the viable cell counting.

## 6.3 Time-to-kill analysis

Briefly, honey solutions were made by firstly preparing  $\frac{10}{9}$  time that of the desired concentration, followed by adding  $0.1 \times$  volume of bacterial inoculum (approximately  $3 \times 10^6$  cfu/ml) in the honey solutions. This way the desired honey concentrations to be tested were obtained, and at the same time the final cell density in the honey solutions was also controlled at approximately  $3 \times 10^5$  cfu/ml so as to be in agreement with the cell density had been used in other chapters. Viable cell counting was conducted at hourly intervals for



6 h (or longer if no significant decline in the viable cell number was seen in the preliminary test for any species).

### 6.3.1 *Methods*

With pure manuka honey and sterile water, 11.1%, 22.2%, 33.3% and 44.4% (w/v) honey solutions were prepared. These honey solutions were further diluted with the same volume of double-strength broth medium so that the final concentrations of the honey solutions would be 5.5%, 11.1%, 16.5% and 22.2%. After filtration through sterile 0.22 µm membranes, 9 ml of filtrant for each concentration was collected in a sterile universal bottle.

To each of the 9 ml honey filtrants, 1 ml of the inoculum was added so that the final honey concentrations in each bottle were 5%, 10%, 15% and 20%. From each of these honey solutions 0.1 ml was removed for viable cell counting using the track dilution method (Section 2.6). The remainder of each inoculated honey solution was incubated at 37°C and viable cell counting was conducted at hourly intervals. The agar plates for viable cell counting were incubated at 37°C overnight. The colonies obtained were counted afterwards and a plot of  $\log_{10}$ CFU/ml vs time (h) was drawn accordingly.

### 6.3.2 *Results*

This section reveals the results of the time-to-kill assay which estimates the time required for manuka honey to kill *E. coli*, *Salmonella* spp., *P. aeruginosa*, *Y. enterocolitica*, *Shigella* spp., *Enterobacter* spp. and *Enterococcus* spp. when the bacterial cells are constantly exposed to honey solutions.

For most of the enteropathogens tested in this study, honey solutions with concentrations higher than the MBC or even MIC were capable of killing the majority (90%) of the organisms within a few hours (Figures 6.1–6.9). *E. coli*, *Yersinia*, *Pseudomonas* and *S. typhimurium* DT104 lost their viability within 2–4 hours in honey solutions whereas it took 4–6 h to kill *S. enteritidis*, *Shigella*, *Enterobacter*.

Some species, on the other hand, were found to be resistant to the bactericidal activity of manuka honey. *Enterococcus* spp., unlike the other gastrointestinal bacteria, appeared to be tolerant to the honey for more than 12 hours (Figures 6.10 and 6.11). *E. faecium* seems to be slightly more susceptible to the honey than *E. faecalis* but still the rate of decline in the cell density was much lower than with the other other gastrointestinal bacteria.

### 6.3.3 Discussion

In Chapter 4 the susceptibility to manuka honey (MIC) with several gastrointestinal organisms was evaluated using the microdilution method which measures the growth curve of an organism in honey solutions at a series of constant concentration through 18 hours. The method is widely used in many laboratories due to its convenience and simplicity, but this also draws some concerns from practical viewpoint. The growth curve only reflects the multiplication of bacterial cells in the media whereas it does not indicate if the cells are being killed or merely temporarily inhibited by the antibacterial agent. To evaluate whether or not the bacterial cells are killed when exposed to the honey for long time, in Chapter 4 the MBC test was also conducted. In that test, most enteropathogens were found to have MBC values at around 6–7% manuka honey whereas for some species the MBC value was rather higher (*Pseudomonas*, *Enterobacter* and *Enterococcus* spp. at approx. 13%; *B. animalis* subsp. *lactis* and *Lactobacillus* at over 16%), suggest-

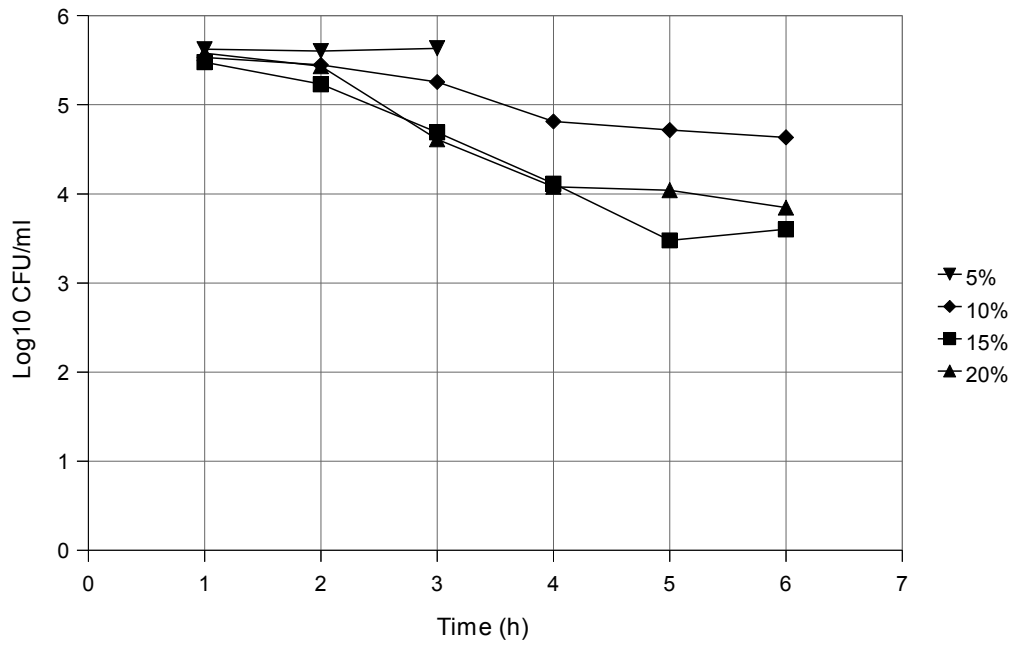

Figure 6.1: The decline in the viable cell number of *E. coli* on incubation in solutions of manuka honey.

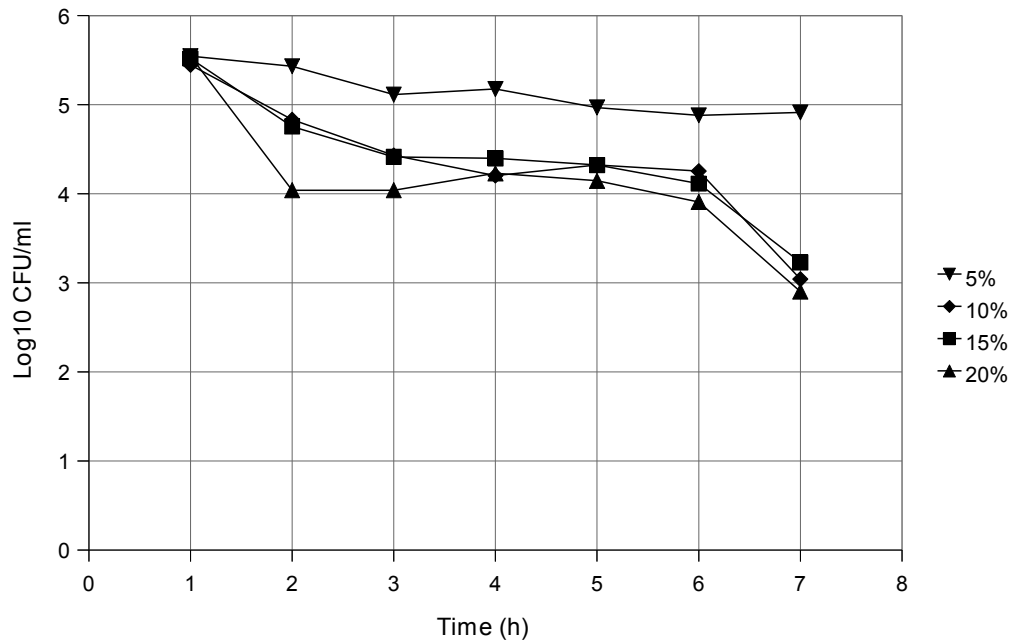

Figure 6.2: The decline in the viable cell number of *S. typhimurium* DT104 on incubation in solutions of manuka honey.

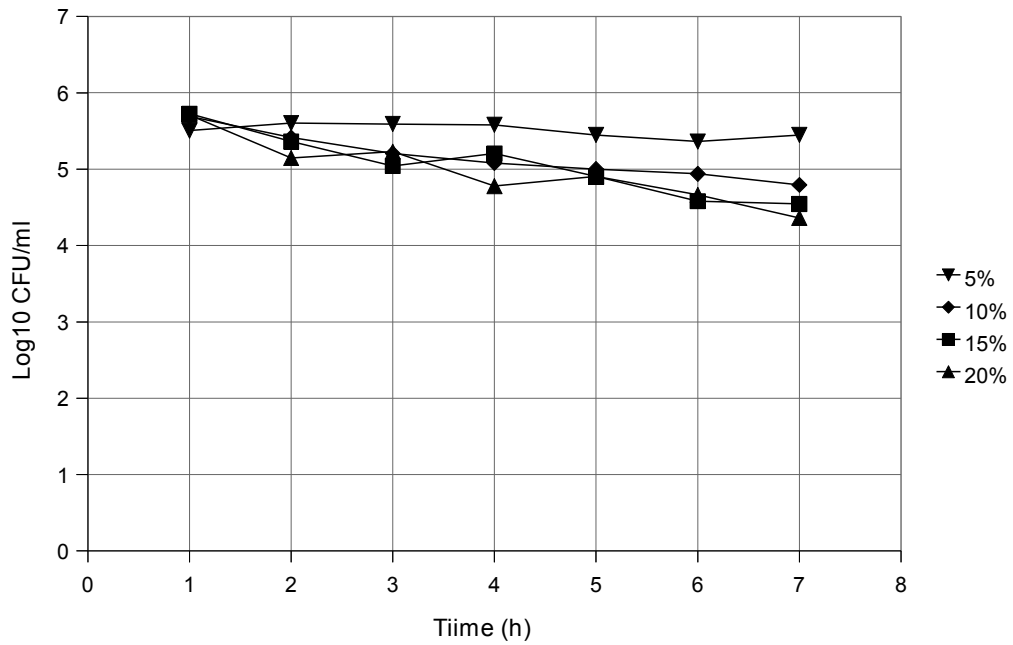

Figure 6.3: The decline in the viable cell number of *S. enteritidis* on incubation in solutions of manuka honey.

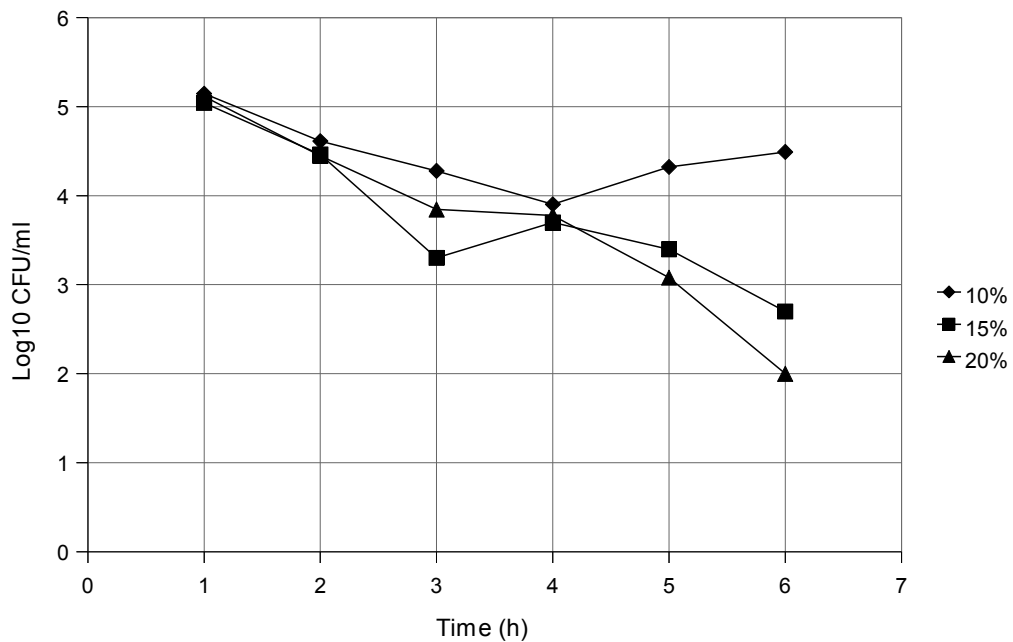

Figure 6.4: The decline in the viable cell number of *P. aeruginosa* on incubation in solutions of manuka honey.

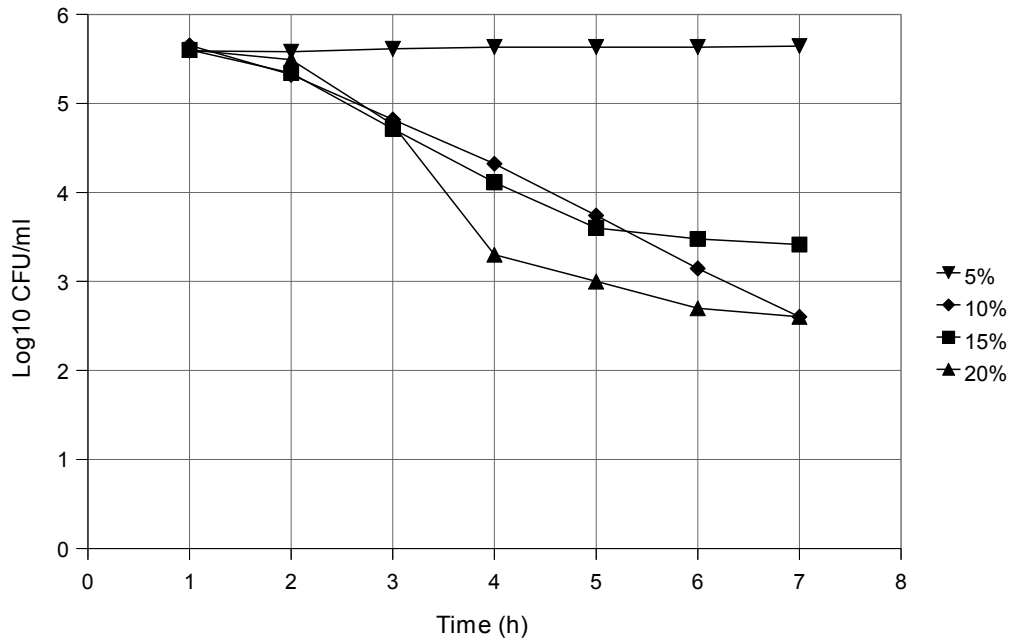

Figure 6.5: The decline in the viable cell number of *Y. enterocolitica* on incubation in solutions of manuka honey.

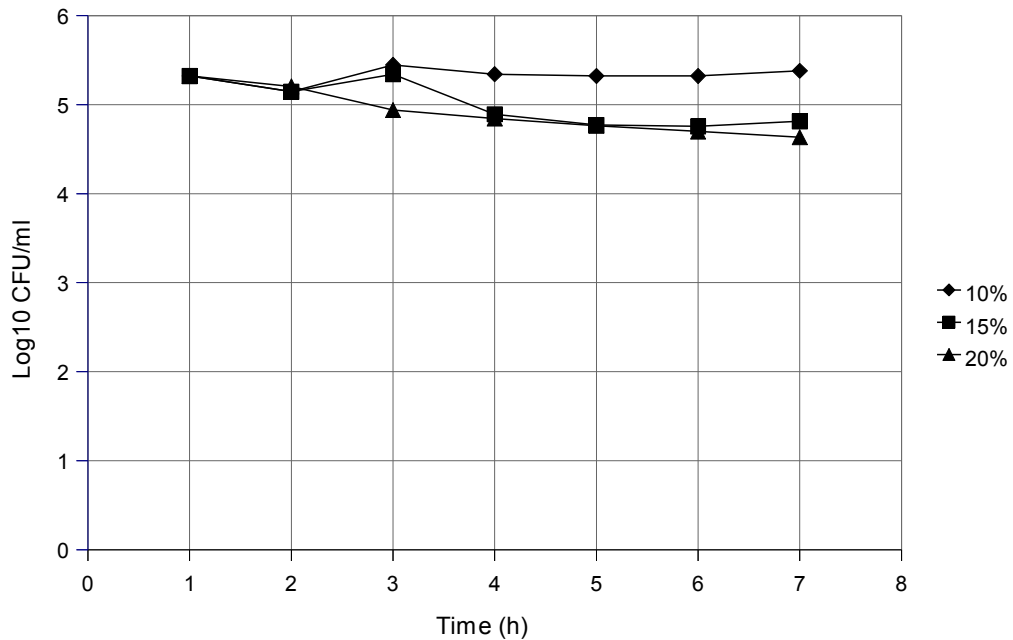

Figure 6.6: The decline in the viable cell number of *E. aerogenes* on incubation in solutions of manuka honey.

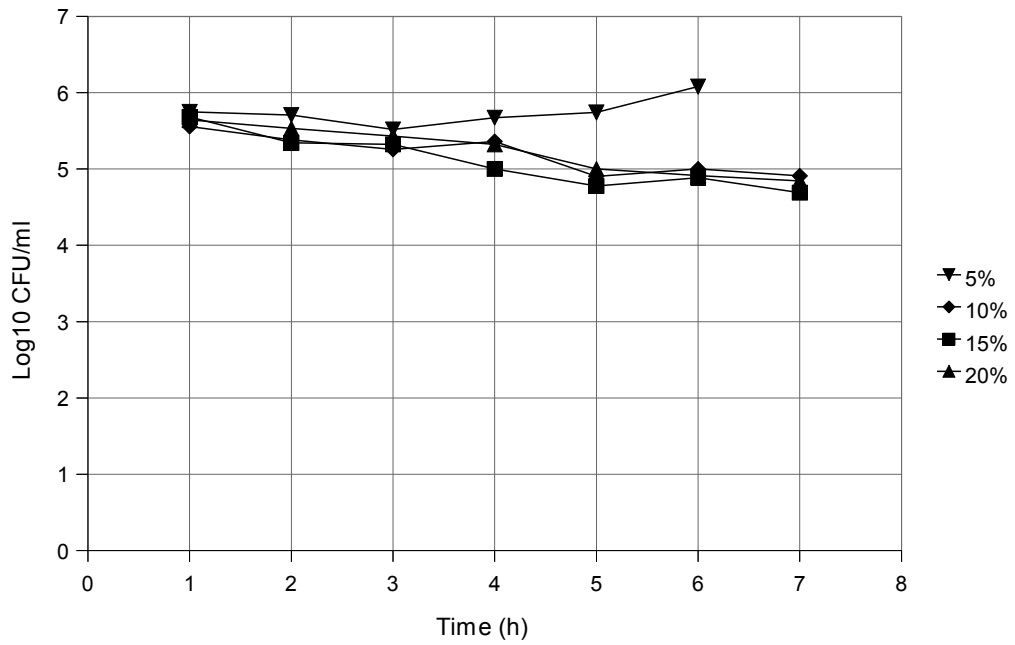

Figure 6.7: The decline in the viable cell number of *E. cloacae* on incubation in solutions of manuka honey.

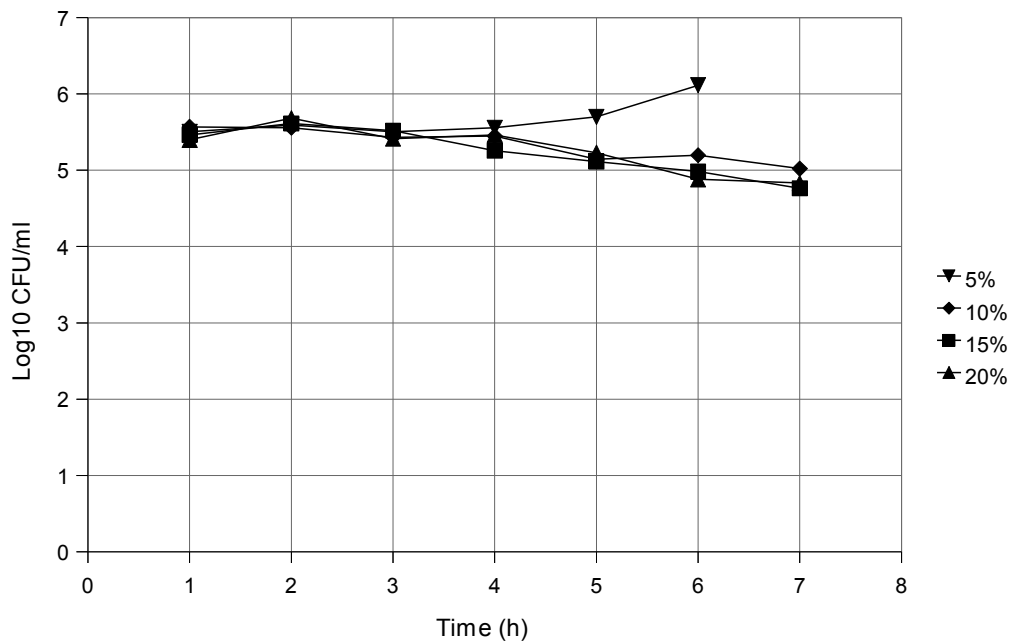

Figure 6.8: The decline in the viable cell number of *S. flexneri* on incubation in solutions of manuka honey.

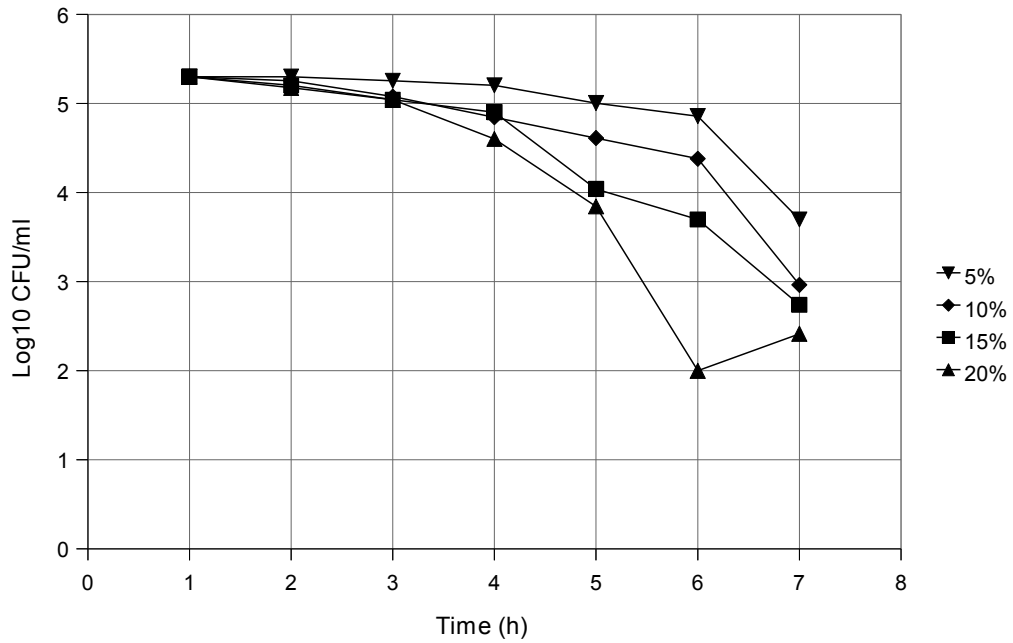

Figure 6.9: The decline in the viable cell number of *S. sonnei* on incubation in solutions of manuka honey.

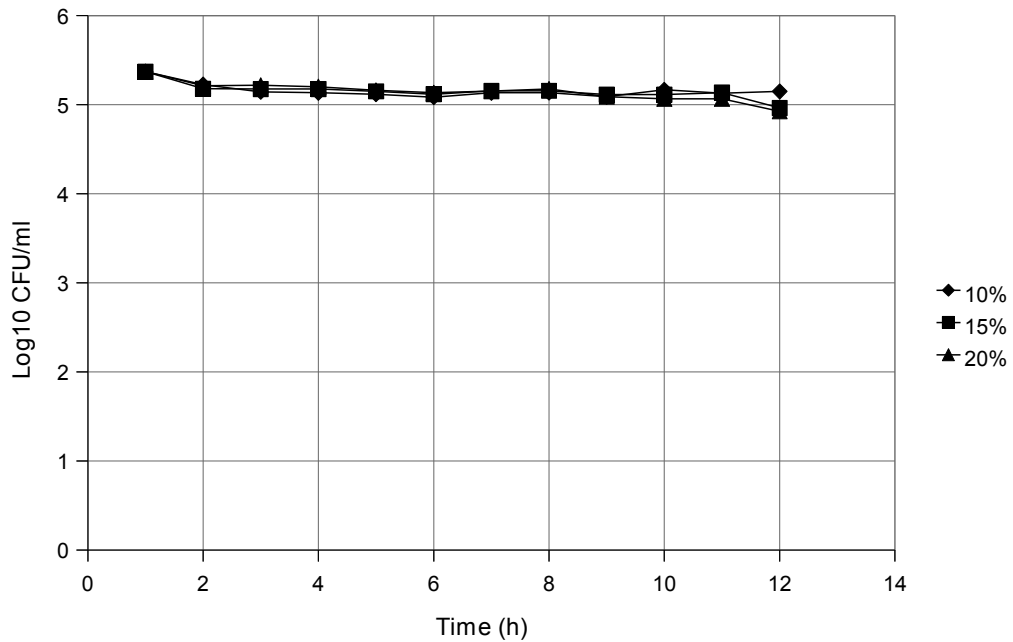

Figure 6.10: The decline in the viable cell number of *E. faecalis* on incubation in solutions of manuka honey.

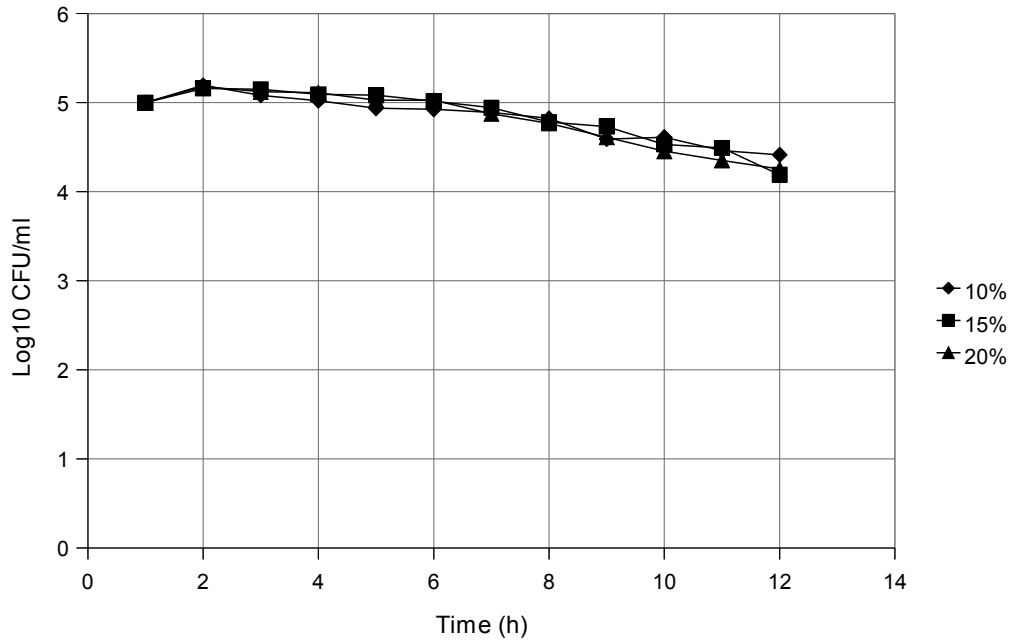

Figure 6.11: The decline in the viable cell number of *E. faecium* on incubation in solutions of manuka honey.

ing that some species may be relatively more tolerant to the antibacterial activity of manuka honey than are the other organisms.

This time-to-kill study, however, seems to have uncovered some hidden information which had not been found in the MIC and MBC studies. In theory, the time required for honey to kill bacteria should be longer if the bacteria reveal higher MBC of the honey because that would mean the bacteria are more tolerant to it. It might take some time for the honey to diffuse into the bacterial cells and have its bioactivity have full effect on the metabolisms in the cells. Comparing with the MBCs in aerobic condition shown in Figure 5.1, however, it can be seen that species with high MBC are not necessarily able to survive in the honey for long time. Among those species that gave high MBC result (approx. 16%), *P. aeruginosa* completely lost its viability within as short time as *Salmonella typhimurium* as long as the honey concentration is higher than the MBC. This suggests that *P. aeruginosa*, and perhaps other species that are not included in this research project, may be actually not as hardy as the impression the high MIC/MBC gives. As



long as the honey concentration is high enough, it is possible to eradicate this species as easily as most of other tested facultative anaerobes like *E. coli*. In other words, the time-to-kill profile may not always be in agreement with the MBC for bacteria.

In contrast to other species, hardly any decline in viable cells could be seen with *Enterococcus* spp. after 11 hours incubation regardless of being constantly incubated even in a high concentration (20%) of honey solution. The number of surviving *Enterococcus* cells might eventually decline down to zero if the incubation is elongated. This would account for the finding that the MBC for this species was ranged from 13.3% to 16% honey (Table 4.5), the incubation time in that experiment being 18 h. The relatively high tolerance of this species in this study is in agreement with Lamont et al. (2006) that *Enterococcus* is a rather resistant pathogenic genus in comparison with other microbes. According to the results obtained in Chapter 4 and here, the honey would need to be kept in contact with the bacterial cells to eradicate this species. This is possible if the honey is used to eradicate enterococcal infection on topical wounds because it is very easy to treat the bacteria by constant cover of the infected site with honey wound dressings or honey gels; however this would not be feasible in the gastrointestinal tract because honey can be easily flushed, diluted or absorbed in the tract. On the other hand, since enterococci play a role in maintaining the microenvironmental ecology in the gut (Murray and Baron, 2003), perhaps this also suggests that some probiotics like gastrointestinal enterococci would generally not be affected by intake of manuka honey.

It must be noted that although manuka honey is now increasingly recognised as an exceptionally effective antibacterial agent, the overall time-to-kill results show that one should not expect manuka honey to eradicate or inhibit microbes within a matter of seconds or minutes. As shown in the time-to-kill test, manuka honey takes at least one hour to have

a microbicidal effect on bacterial cells when at a concentration of 20% and a longer time if its concentration is lower. Practically, this also means that the MIC/MBC for gastrointestinal pathogens is not meaningful because the actual concentration of the honey is unlikely to be maintained above the MIC level for that length of time. In the next section, therefore, what would happen to bacterial growth if honey contacts the cells only for a short time is explored.

## 6.4 The post-antibiotic effect of manuka honey on organisms

Because of the complexity of the postantibiotic test, a brief outline of the whole process is firstly given here, and the exact details are described chronologically in the next subsection.

Firstly, a honey solution was made by preparing  $\frac{10}{9}$  time that of the desired concentration and transferred in a 15 ml centrifuge tube. MHB with the same volume as the honey solution was also prepared in another centrifuge tube as a control. For each species, a tube with honey and another tube for control were handled simultaneously (*i. e.* two tubes for one species). A broth culture with approximately  $3 \times 10^6$  cfu/ml was prepared. The broth culture with  $0.1 \times$  volume of that of the honey solution was then added so that the desired honey concentrations to be tested were obtained, and at the same time the final cell density would be approximately  $3 \times 10^5$  cfu/ml, the cell density that had been used in other chapters. All tubes were incubated for 1 h to induce the postantibiotic effect, with viable cell counting being conducted right after the incubation. The bacteria were washed by centrifuging the tubes and replacing the supernatant with pre-warmed MHB. After this, all tubes were incubated with viable cell counting being

conducted at hourly intervals until a significant increase in the turbidity was seen visually in the honey-treated tube.

To check the sterility, an additional centrifuge tube with MHB was also included. This MHB tube was handled in the same way as the testing group described above through the whole process, except that the bacterial broth culture was replaced with MHB.

Most the viable cell counting was conducted using the track dilution method as described in Section 2.6. Before the postantibiotic test being conducted, 0.9 ml of MHB in bijoux bottles was prepared as described in Section 6.2.3 as the diluent for serial dilution. The dilution range of the series was  $10^{-1}\times$ ,  $10^{-2}\times$ ,  $10^{-3}\times$ ,  $10^{-4}\times$ ,  $10^{-5}\times$ ,  $10^{-6}\times$ ,  $10^{-7}\times$  and  $10^{-8}\times$ . Also, the conventional streak plate technique was used to count the cell number in case the cell density was predicted to be less than the detectable range of the track dilution method (*i. e.*  $< 10^3$  CFU/ml). This was done by spreading 0.1 ml and 1 ml of broth culture on two MHA plates. The detectable range of the cell number in the works in the postantibiotic effect test, therefore, would be from 10 CFU/ml to  $10^{12}$  CFU/ml.

To control the growth speed of bacteria, all media and solutions used in this study were pre-warmed at 37°C before used.

### 6.4.1 *Methods*

The following describes the method used for the postantibiotic assay for each species in 20% manuka honey M115.

#### 6.4.1.1 Day 1 - Preparation

One day before the experiment 3.09 g honey was weighed out and stored in a dark refrigerator.

Also, stock culture from the  $-70^{\circ}\text{C}$  freezer was recovered by incubating on MHA at  $37^{\circ}\text{C}$  overnight. A single colony of the recovered culture was taken to ensure that this was a pure culture and this was inoculated into 10 ml MHB and was further incubated at  $37^{\circ}\text{C}$  overnight.

#### 6.4.1.2 Day 2 - PAE induction

To ensure the culture was in the log phase, 1 ml of the overnight culture was transferred to another 10 ml fresh MHB, and incubated for another 2 h at  $37^{\circ}\text{C}$ . While waiting for this incubation to finish, 10 ml 22.2% (v/v) honey solution (3.09 g honey, 5 ml double strength MHB and 2.78 ml water) was prepared. This honey solution was filtered through a  $0.22\ \mu\text{m}$  sterile membrane and from the filtrant 9 ml was transferred to a sterilised 15 ml centrifuge tube (Greiner Co.). Another sterilised 15 ml centrifuge tube filled with 9 ml sterile MHB was also prepared as a control. Both tubes, along with a bottle of MHB, were kept at  $37^{\circ}\text{C}$  until use.

While pre-warming the solutions stated above, the inoculum was prepared as described in Section 6.2.1 so that the bacterial cell density would be approximately  $3 \times 10^6$  CFU/ml.

To the contents of each pre-warmed centrifuge tube, 1 ml of inoculum solution was added, mixed well, then 100  $\mu\text{l}$  of the broth culture was removed from each tube and serially diluted with pre-dispensed 0.9 ml MHB. All tubes were then incubated in a shaking incubator for 1 h ( $37^{\circ}\text{C}$ , 150 rpm). While waiting for the incubation, each serially diluted broth culture (10  $\mu\text{l}$ ) was loaded onto square agar plates for viable cell counting and the plates were incubated at  $37^{\circ}\text{C}$  overnight. This time point was recorded as " $t_0$ " and the result of CFU counting as " $C_0$ " to check if the starting cell density in the tubes with honey and for control are approximately the same.

1 h after " $t_0$ ", 100  $\mu\text{l}$  was taken from each tube and serially diluted in 0.9 ml MHB as before, then all tubes were centrifuged at  $1\ 600 \times g$  for 10 min at

room temperature. Meanwhile, the serial diluted inocula were loaded onto square agar plates as before and incubated at 37°C overnight. This time point was recorded as “t<sub>1</sub>” and the CFU result as “C<sub>1</sub>”.

After centrifuging, the 9 ml supernatant in each tube was carefully replaced with the same volume of warm MHB without disturbing the pellets so as not to suck the bacteria in the pellets into the pipette along with the supernatant. The bacteria in the pellets were then washed by vortexing the tubes for 2 seconds, then centrifuging for 10 min at 1 600 ×g and replacing with fresh warm MHB. The washing was then repeated twice. Then 100 µl was taken from each of the tubes for viable cell counting as before. The time point and CFU results were recorded as “t<sub>2</sub>” and “C<sub>2</sub>” respectively. The tubes were then incubated in a shaking incubator (37°C, 150 rpm) for 1 hour. Note that theoretically the washing should have taken 30 min (three washings, 10 min for each time), but in practice the washing process took approximately 1 h.

After “t<sub>2</sub>”, serial dilution for viable cell counting and further incubation were repeated every 1 hour, and the time stage and CFU results were recorded as “t<sub>3</sub>”, “t<sub>4</sub>”, “t<sub>5</sub>” and “C<sub>3</sub>”, “C<sub>4</sub>”, “C<sub>5</sub>” and so on until a significant increase in the turbidity was observed visually in the honey-treated tube.

#### 6.4.1.3 Day 3 - PAE evaluation

After the overnight incubation of the agar plates, the viable colony forming units on each agar plate were counted and the cell density (CFU/ml) for each time point was calculated. A “log<sub>10</sub> (CFU/ml) vs time” chart was drawn accordingly as shown in Fig 6.12.

The PAE was obtained from the following formula:  $PAE = T_2 - T_1$  where  $T_2$  is the time the honey-treated bacteria required to increase by 1 log<sub>10</sub> in viable count after washing, and  $T_1$  is the time the control group required under the same conditions.

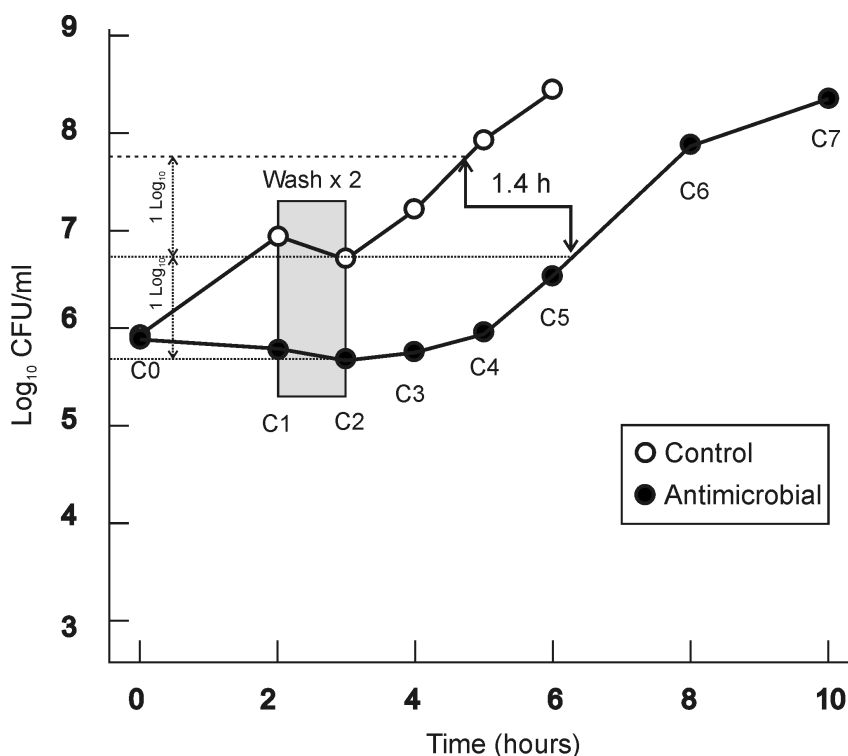

Figure 6.12: An illustrative graph of the calculation of the postantibiotic effect (PAE). In this figure the PAE is 1.4 hours. Source: adapted from Craig (1996).

## 6.4.2 Results and discussion

This section describes the result of postantibiotic effect (PAE) on enterobacteria caused by 20% (v/v) manuka honey. The “log<sub>10</sub> (CFU/ml) vs time” charts for the various species of bacteria are shown in Figures 6.13–6.26. It must be emphasised that the postantibiotic effect test is to examine whether the exposure to honey has affected the metabolism of the bacterial cells that remain alive, so that their subsequent growth is slowed. In other words, the study is to investigate for how long the rate of growth after 1 h exposure to and 1 h washing process of honey (*i.e.* gradient of the log plots after  $t_2$ ) remains less than the control before they becoming parallel.

Traditionally, the postantibiotic effect assay is done by monitoring the recovery of antibiotic-treated bacteria in terms of CFU/ml. In carrying out this work here, several serious drawbacks with this assay came to light. It takes a long time to prepare, execute and finish the test, which

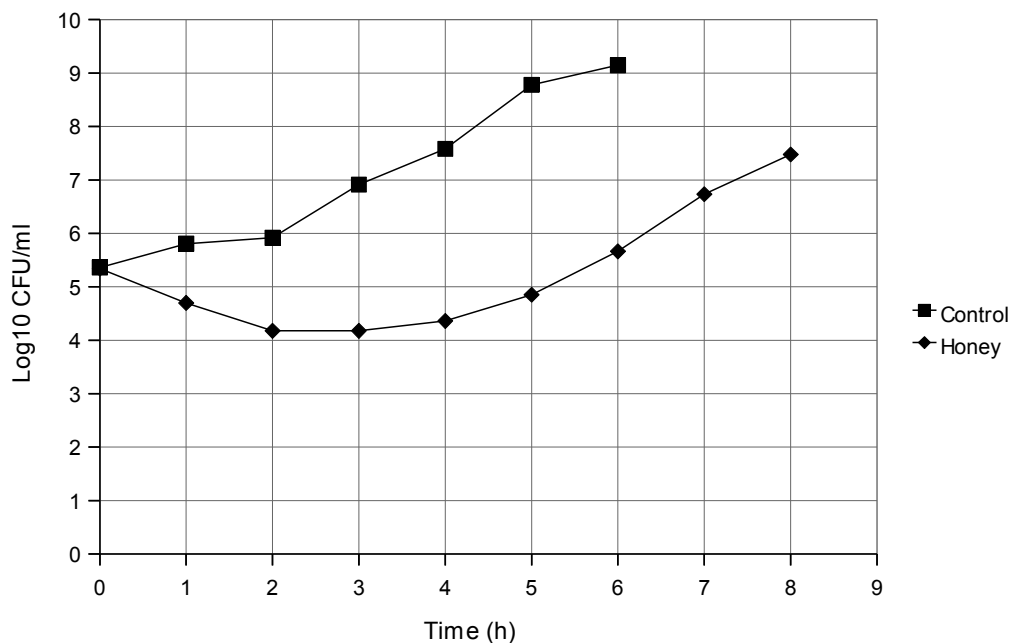

Figure 6.13: The postantibiotic effect of manuka honey on *E. coli*.

results in taking up as long as almost one week to run one single test. The lengthy process during the test could largely increase the chance of contamination and mistake, both of which are critical because otherwise it is almost impossible to obtain a good quality colony counting results at the end (as can be seen from the Figures). It was also found to be impossible to handle more than 2 species *i. e.* 5 tubes (two tubes for each species, plus one tube for sterility control) in a run because it would take too much time to handle the samples, and the time needs to be strictly controlled (particularly when washing honey off by centrifuging, and also when serially diluting and inoculating bacteria on agar plates hourly). The requirement in time control also had made it impossible to conduct any replication in each single test because this would greatly increase the number of apparatus and media, and therefore the handling time. The lack of replication could have led to the difference in the bacterial cell number at the starting point between the tube with honey treated and the tube for control in some species (Figures 6.15, 6.20, 6.21 and 6.23). Repetitive fluctuation in broth temperature may effect the growth of “recovering” bacteria. Not knowing

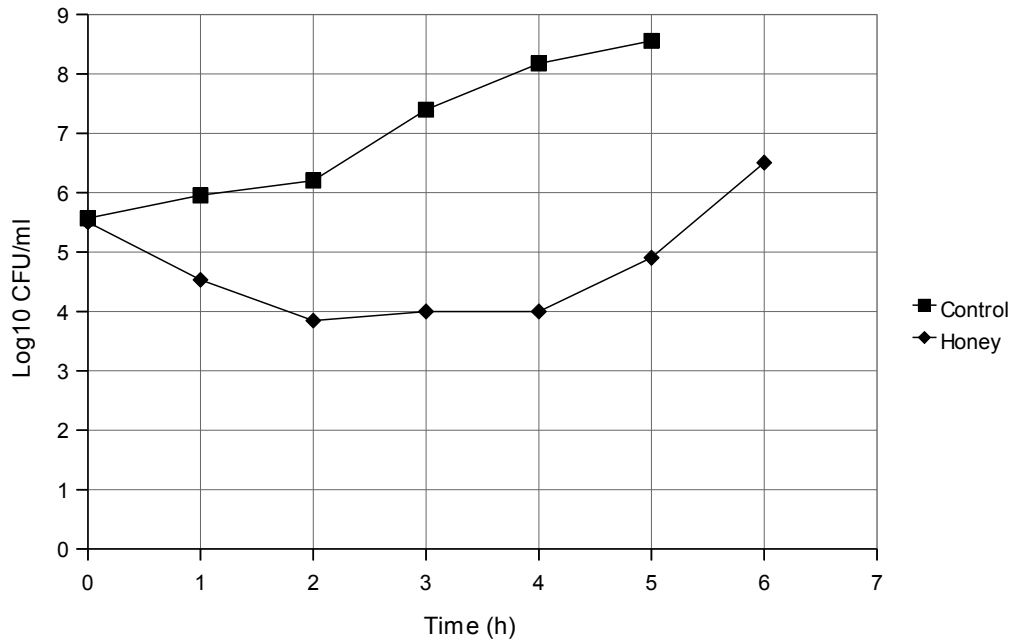

Figure 6.14: The postantibiotic effect of manuka honey on *S. typhimurium* DT104.

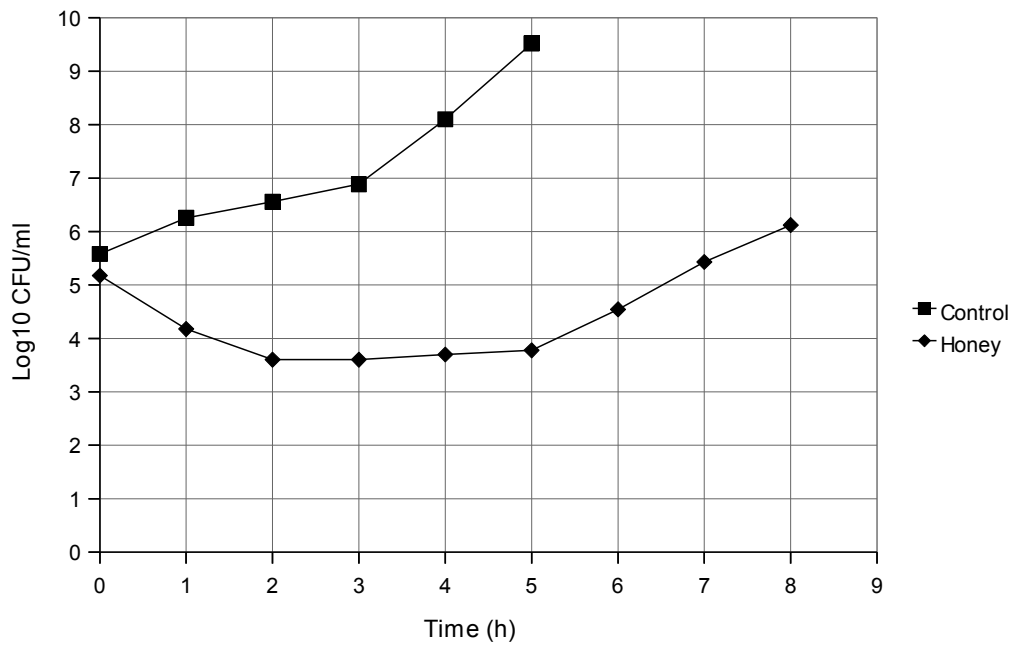

Figure 6.15: The postantibiotic effect of manuka honey on *S. enteritidis*.



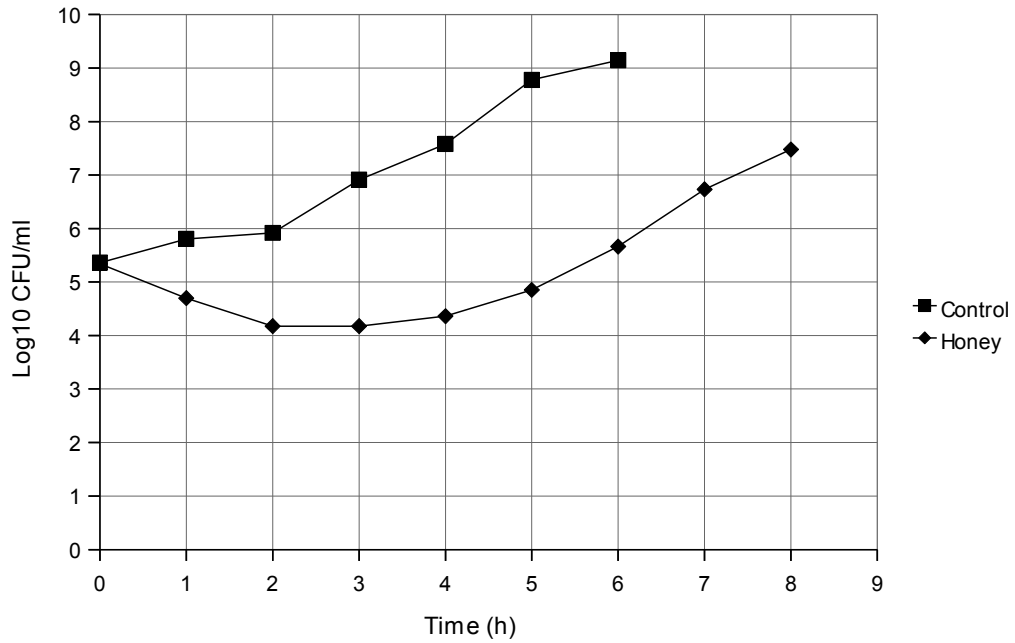

Figure 6.16: The postantibiotic effect of manuka honey on *P. aeruginosa*.

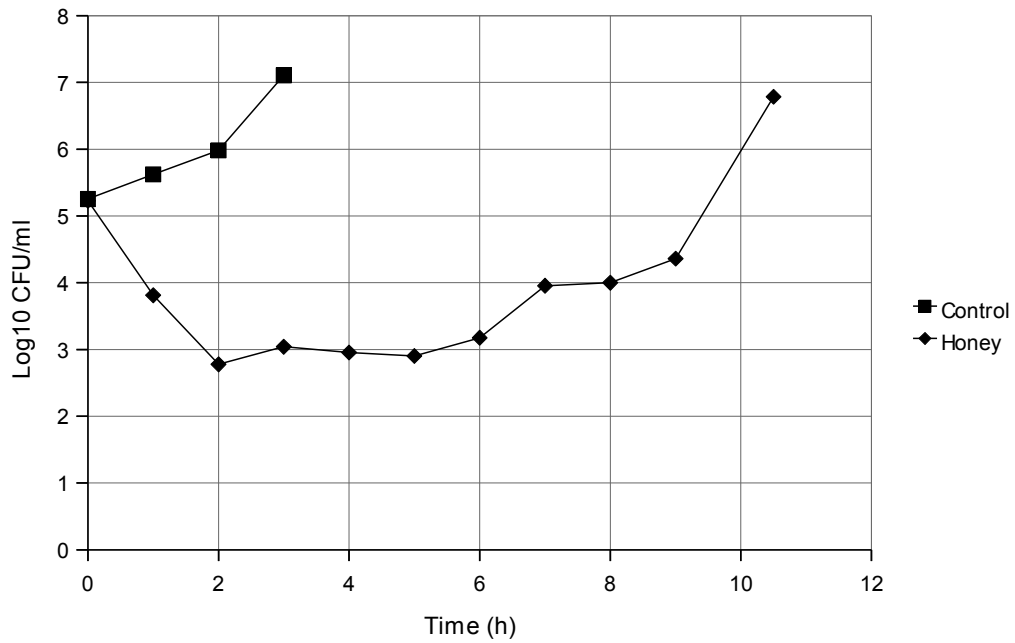

Figure 6.17: The postantibiotic effect of manuka honey on *Y. enterocolitica*.

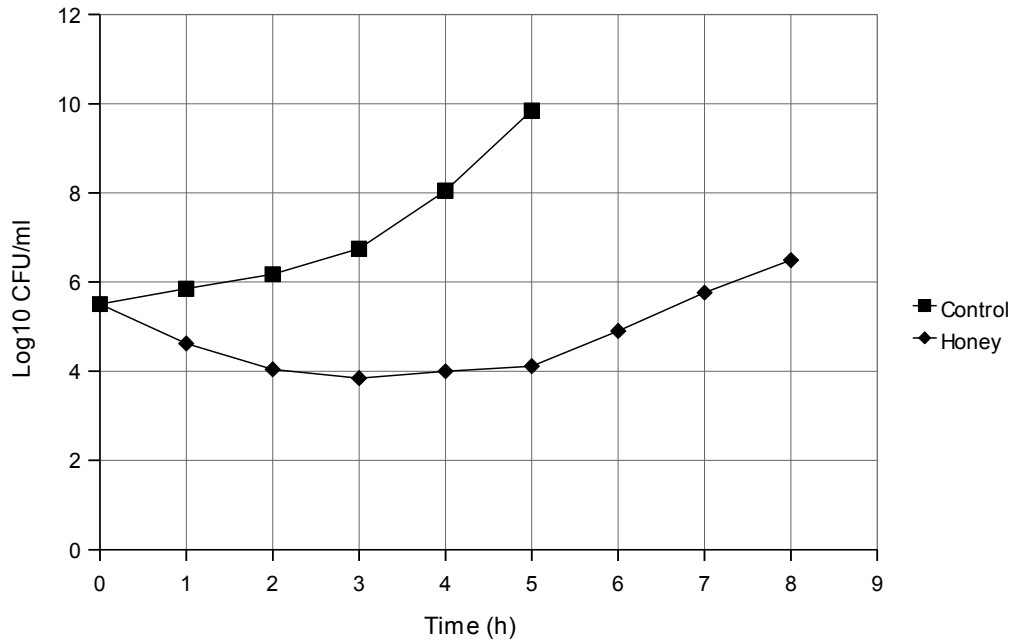

Figure 6.18: The postantibiotic effect of manuka honey on *E. aerogenes*.

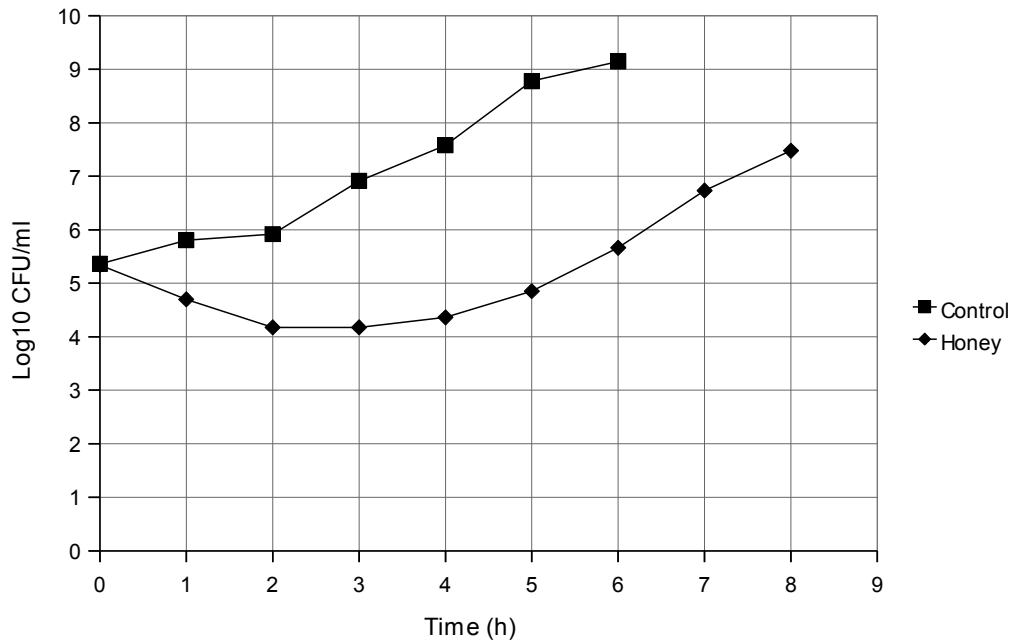

Figure 6.19: The postantibiotic effect of manuka honey on *E. cloacae*.

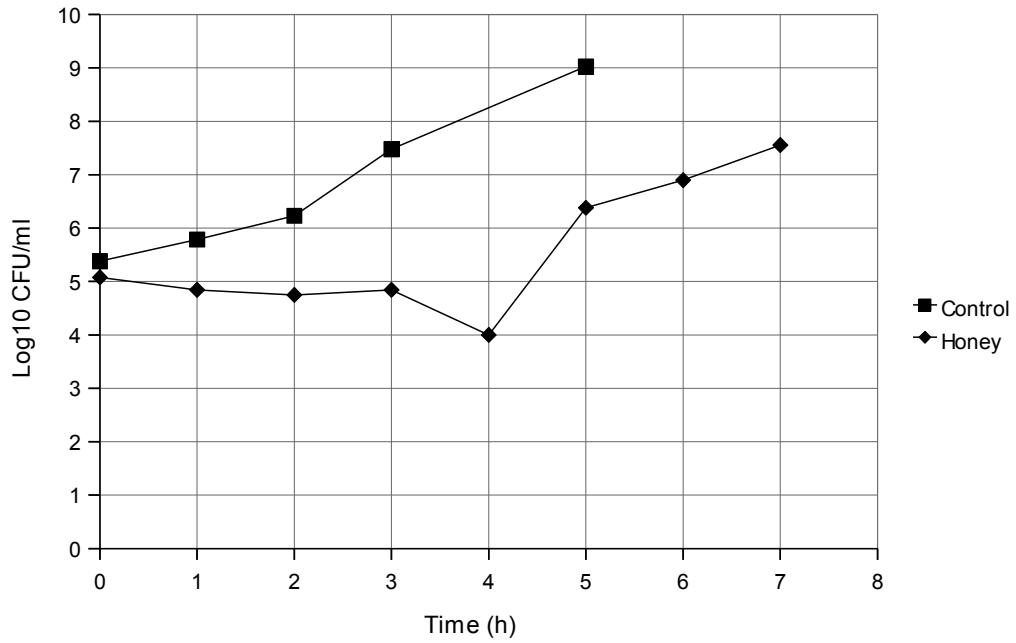

Figure 6.20: The postantibiotic effect of manuka honey on *S. flexneri*.

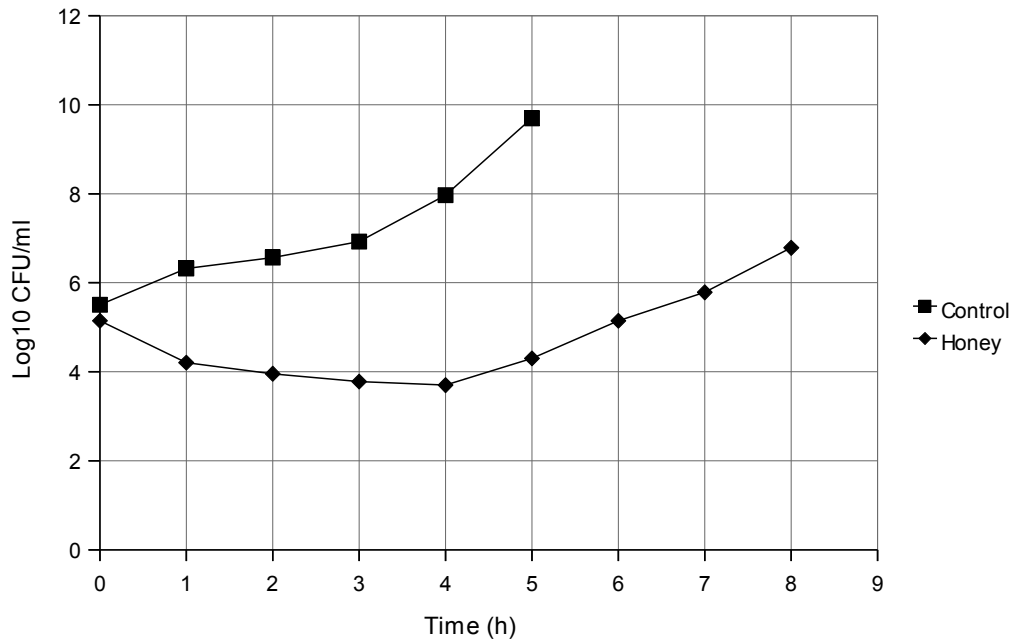

Figure 6.21: The postantibiotic effect of manuka honey on *S. sonnei*.

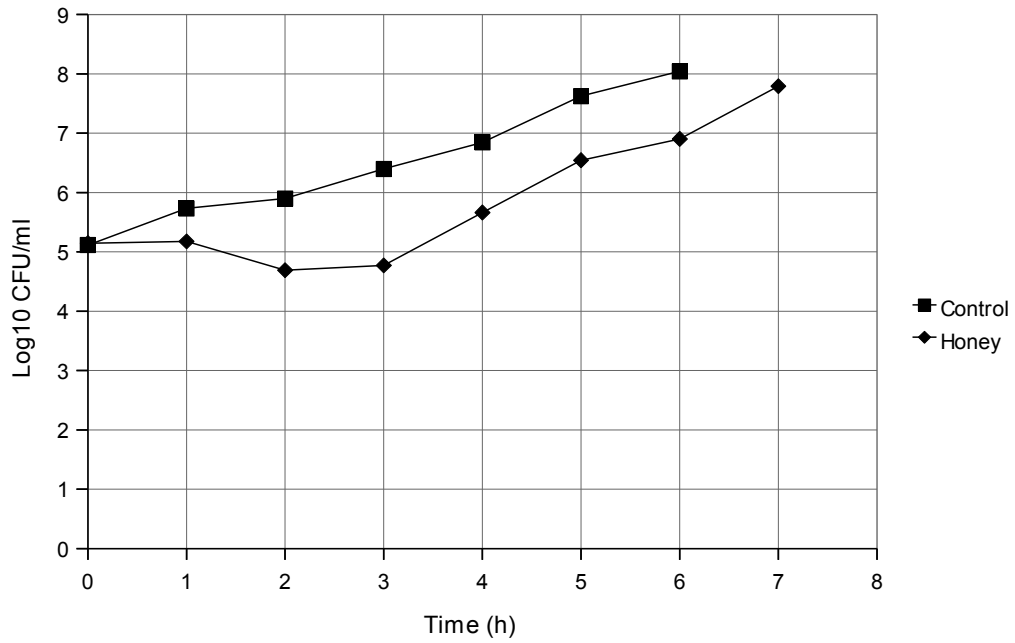

Figure 6.22: The postantibiotic effect of manuka honey on *E. faecalis*.

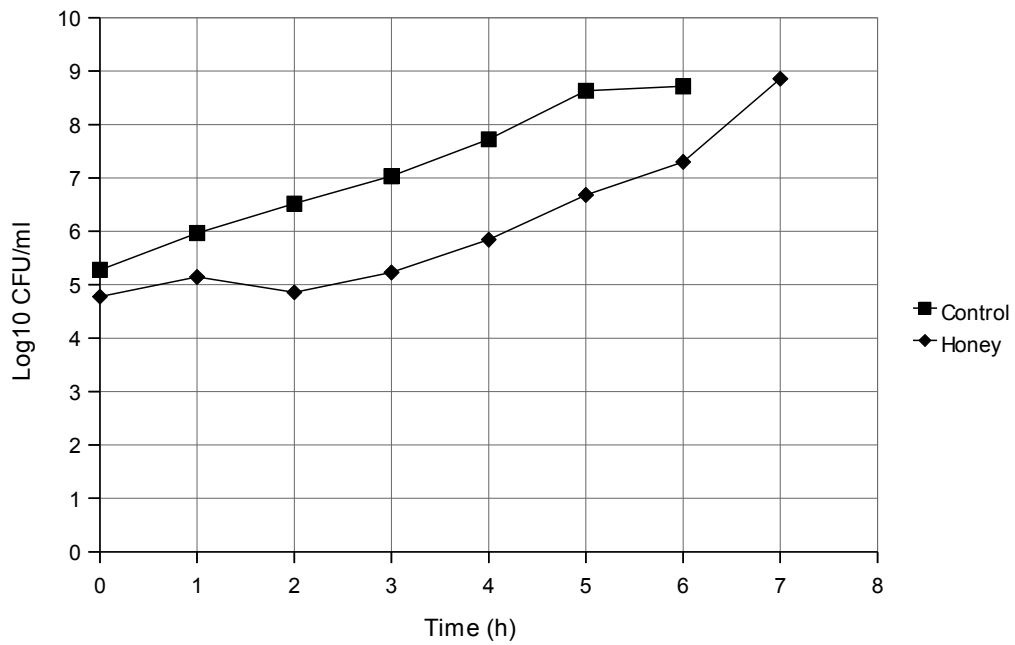

Figure 6.23: The postantibiotic effect of manuka honey on *E. faecium*.

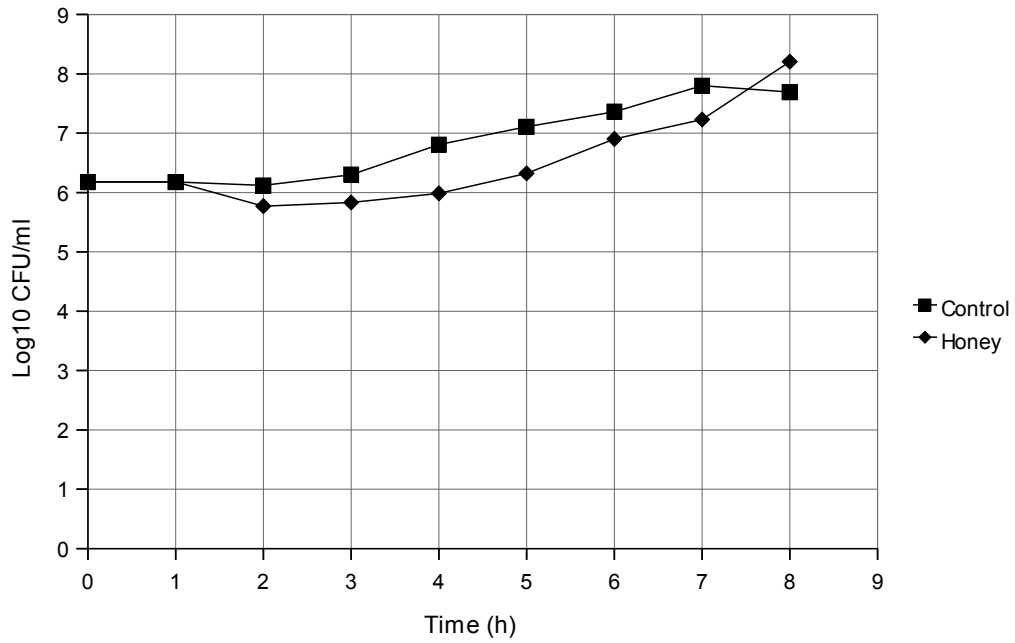

Figure 6.24: The postantibiotic effect of manuka honey on *B. animalis* subsp. *lactis*.

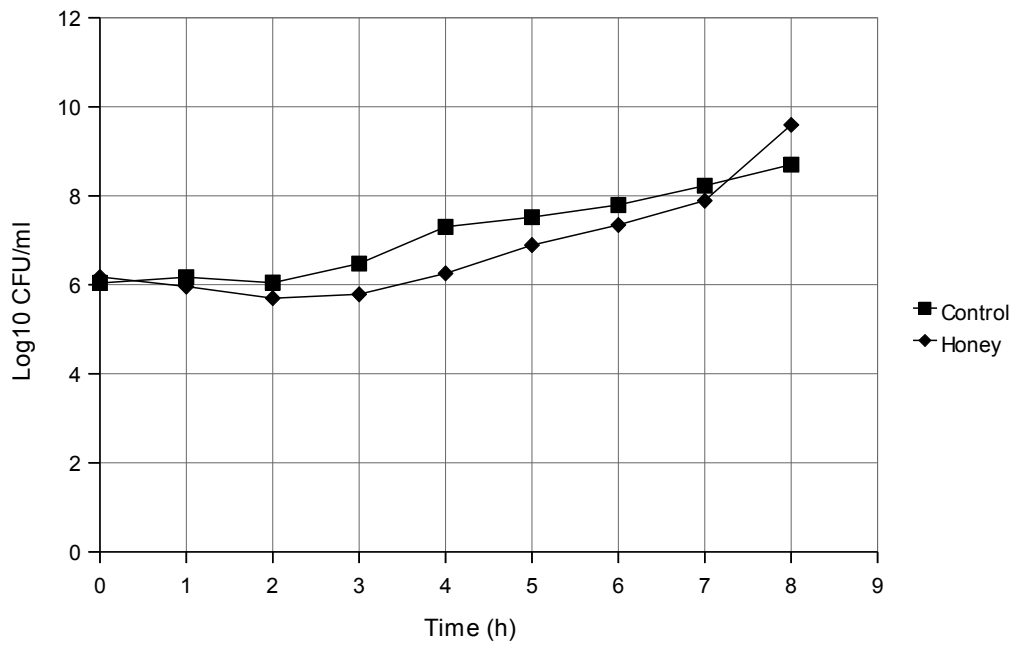

Figure 6.25: The postantibiotic effect of manuka honey on *L. plantarum*.

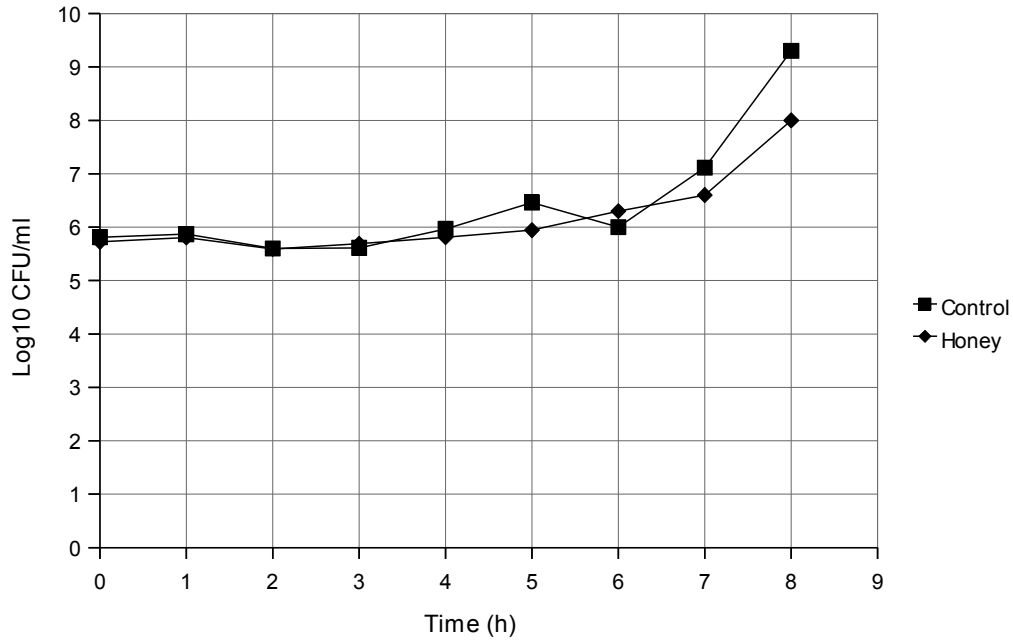

Figure 6.26: The postantibiotic effect of manuka honey on *L. rhamnosus*.

the range of CFU during the incubation in fresh broth after washing means a wide range of serial dilution was needed (hence large amount of agar plates, diluent and handling time is required). Also, not knowing how long it would take bacteria to re-grow after honey is removed means a single test could take as long as or more than 12 hours. With all the issues described above, the estimation of the postantibiotic effect values therefore cannot be precise. Nevertheless, these data do allow the author to see that there are big differences between species in the postantibiotic effect of manuka honey.

Similar to the findings with the time-to-kill test, the results from the postantibiotic tests showed that the MIC/MBC may not fully describe the susceptibility of bacteria to manuka honey. The susceptibility test result showed that for most species the MIC was 5–10% honey and the MBC was 8.5–16% honey, whereas postantibiotic effects of manuka honey on these species seems to be not always proportional to the MIC or the MBC. Generally most organisms such as *Salmonella* spp. and *E. coli* have the MIC of 7–8% and the postantibiotic effect of around 2–2.5 h. For *Enterobacter* spp., for which the MIC and MBC values are relatively higher, a moderate

postantibiotic effect of around 2–2.5 h was also obtained. For *Y. enterocolitica* the MIC and MBC were very low. With this species there was a longer postantibiotic effect than with most other organisms (nearly 4.5 h). With *P. aeruginosa* it was expected that there would be a minor postantibiotic effect because of the high MIC for this species, whereas the results revealed that the postantibiotic effect was surprisingly long (more than 3.5 h). On the other hand, hardly any postantibiotic effect was observed with *E. faecalis* and *E. faecium* (less than 0.5 h). A similar result was seen with the probiotics *B. animalis* subsp. *lactis*, *L. plantarum* and *L. rhamnosus*.

The length of the prevention of bacterial regrowth by manuka honey may be due more to its bactericidal effect on bacterial cells than to the MIC. For comparison, the results of the MIC test as well as those of pharmacodynamics are placed side by side (Figure 6.27). From Figure 6.27 it is also clear that the species with higher time-to-kill results require a very short time for recovery. It is possible that the honey concentration used in the time-to-kill and the PAE tests (20%) being just above the MIC for *B. animalis* subsp. *lactis*, *Lactobacillus* and *Enterococcus* may have been responsible for the long time-to-kill result and short PAE. A shorter time-to-kill and longer PAE would be expected if higher concentration of honey were used to treat the species. However, this hypothesis is not supported by the observations with *P. aeruginosa* because the results with *P. aeruginosa* should have had a similar trend as there was with these species. Also, for those species with short time-to-kill results, the honey concentration at just above MIC did not elongate the result in the time-to-kill studies as much as more than 10 hours. An alternative possibility is that perhaps manuka honey has different modes of bactericidal action on different species. Several antibiotics, for instance daptomycin, are known to have rapid bactericidal effects at or just above the MIC (Fuchs et al., 2002; Rybak et al., 2000), and the situation observed in *P. aeruginosa* is somewhat similar to this, although a surprising phenomenon

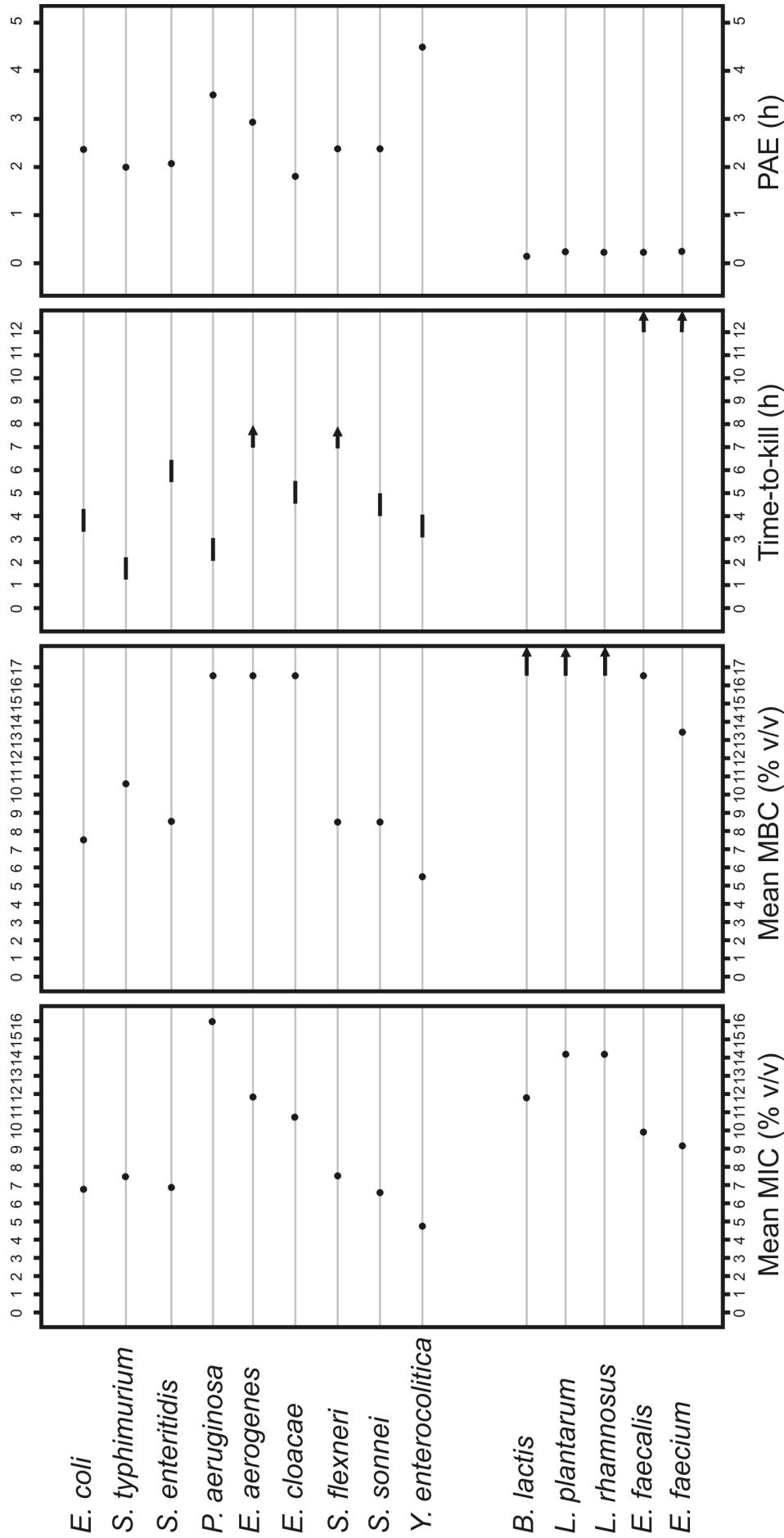

Figure 6.27: A dot plot of data from the MIC, MBC, time-to-kill and postantibiotic effect (PAE) tests with manuka honey M115. MIC and MBC data are from Chapter 4. Time-to-kill and PAE data are those obtained using 20% manuka honey M115 in this chapter. Time-to-kill data are shown with bars instead of plots to demonstrate the approximate range of term the manuka honey M115 (20%) takes to kill 90% of bacteria. Testing results out of the detectable range are shown with arrows.



seen in daptomycin, the delay in the growth of microbes at concentration just below the MIC or even as low as 0.2 times the MIC for more than 12 hours (Pankuch et al., 2003) is not observed in our study. It is possible that the bactericidal mechanisms in manuka honey may be especially effective with some species (*P. aeruginosa* and *Y. enterocolitica* in this study), and be moderately effective to most other species (*E. coli*, *Salmonella*, *Enterobacter* and *Shigella*) and be of relatively low effectiveness to the probiotics used in this study.

The postantibiotic effect and time-to-kill are increasingly important pharmacodynamic parameters in clinical areas because these provide information on optimising the therapeutic regime in response to the increasing prevalence of bacterial species resistant to antibiotics. Especially the former may help reduce the dose or increase the interval between doses by investigating how an antimicrobial agent affects bacterial cells after being removed.

#### **6.4.3 *A spectrophotometric method for the post-antibiotic assay - a trial***

Given that several issues had severely restricted the efficiency of the pharmacodynamics assay that is based on the standard viable counting technique, a spectrophotometrical method using a microtiter plate reader was considered to improve the efficiency. This spectrophotometrical method shares in the postantibiotic effect induction and honey removal with the conventional cell-counting based method, but differs from the traditional counterpart in two aspects. Firstly, the monitoring of the bacterial recovery after the cells being washed was done by a microplate reader with a built-in incubator (BMG FLUOstar OPTIMA) so that the number of simultaneously handleable sample is increased whilst the overall working load is largely decreased.

Secondly, the postantibiotic effect is determined by examining the difference in the time the honey-exposed and control bacteria required to reach parallel log phase in the monitoring growth curve (Figure 6.28).

This spectrophotometric method was tried to compare the postantibiotic effect of 20% of manuka honey M115 with that obtained using the standard method. It was also intended to try to compare the postantibiotic effect induced by different concentrations of honey with different types of antibacterial activity. A series of binary diluted (20%, 10% and 5%) manuka honey M115, honeydew (a honey with peroxide activity as its only antibacterial activity) and artificial honey were included in this trial. Each of the honey samples was further subdivided into that with and without 0.1% catalase added. Because the spectrophotometric method was not well standardised at this stage, only *E. coli* was included in the test (Figures 6.29, 6.30 and 6.31).

Comparing Figure 6.31 with the postantibiotic effect of 20% manuka honey on *E. coli* with the traditional method (Figure 6.13), however, it is seen that the spectrophotometric method gave a significantly longer postantibiotic effect (3–4 h) than the ones obtained from the viable counting method (1–2 h). The cause of the difference is yet to be found. In theory, the two methods should have given similar results because the treatment on the

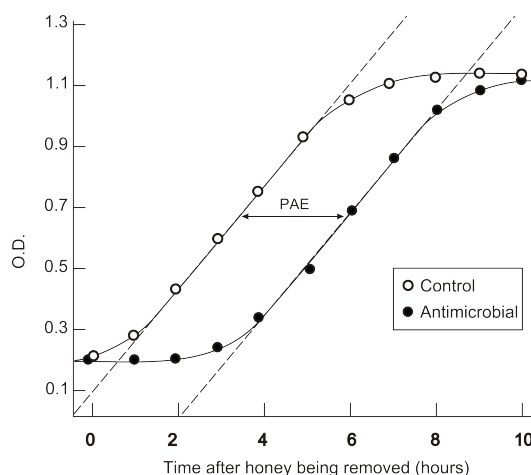

Figure 6.28: Theoretical graph of postantibiotic effect (PAE) determination using spectrophotometry.

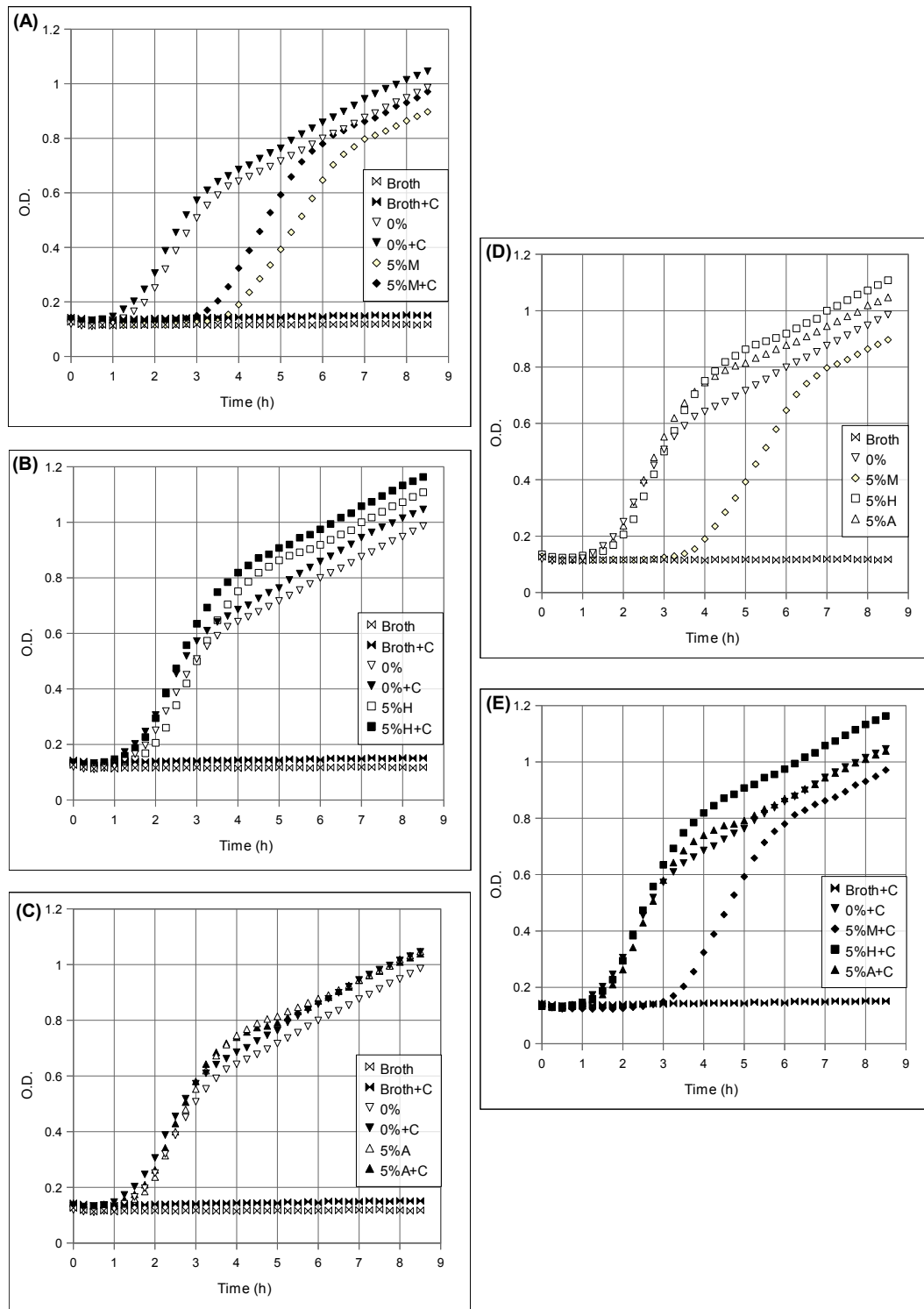

Figure 6.29: Growth curves monitored by a microtiterplate reader of *E. coli* culture after 1 hour exposure of 5% honey. Comparisons of the growth curves are made within subfigures (A): manuka honey M115, (B): honeydew honey, (C): artificial honey, (D): honeys without 0.1% catalase added, and (E): honeys with 0.1% catalase added. Abbreviations used in the keys: M, manuka honey M115; H, honeydew honey; A, artificial honey; C, catalase solution (0.1%).

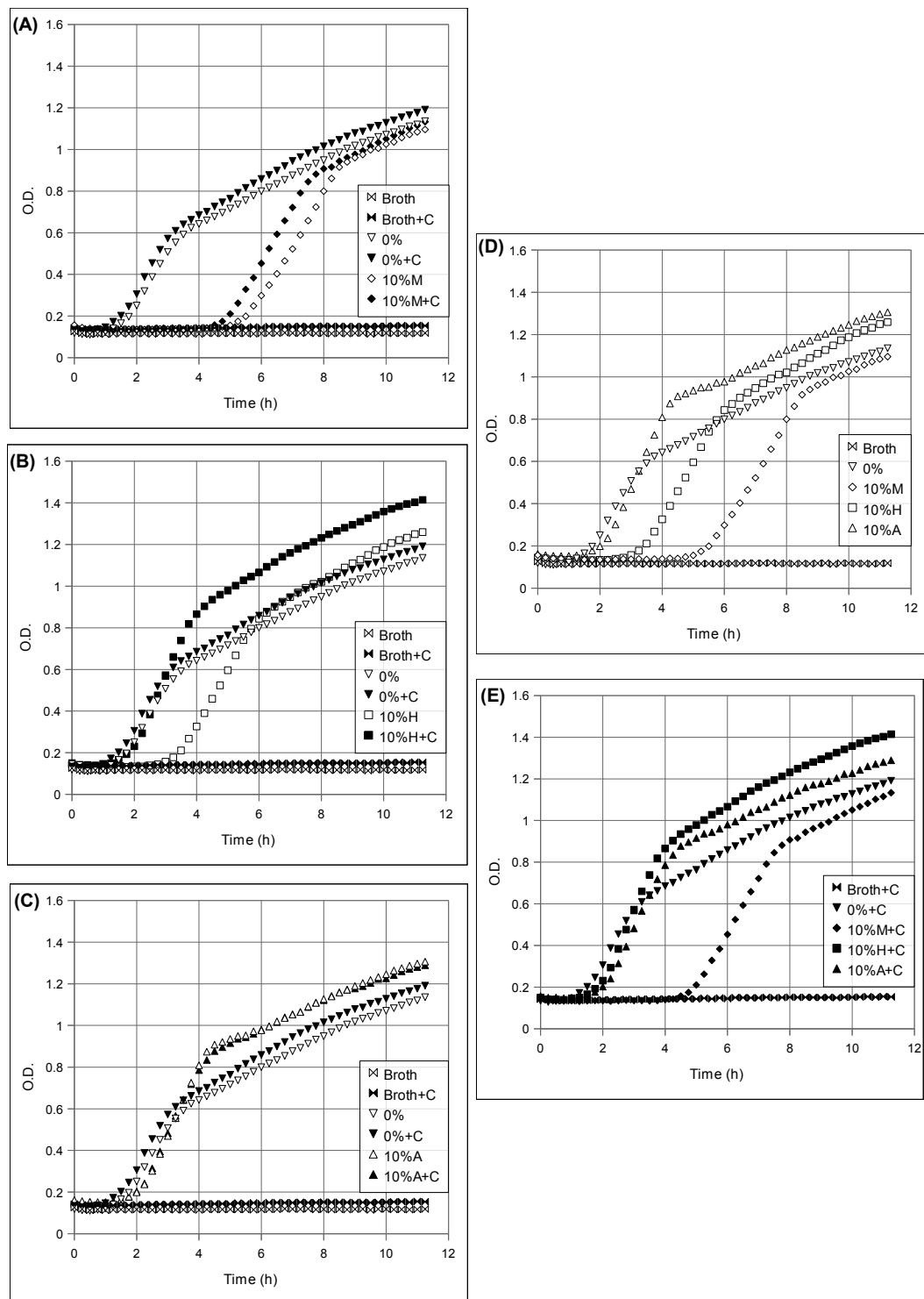

Figure 6.30: Growth curves monitored by a microtiterplate reader of *E. coli* culture after 1 hour exposure of 10% honey. Comparisons of the growth curves are made within subfigures (A): manuka honey M115, (B): honeydew honey, (C): artificial honey, (D): honeys without 0.1% catalase added, and (E): honeys with 0.1% catalase added. Abbreviations used in the keys: M, manuka honey M115; H, honeydew honey; A, artificial honey; C, catalase solution (0.1%).

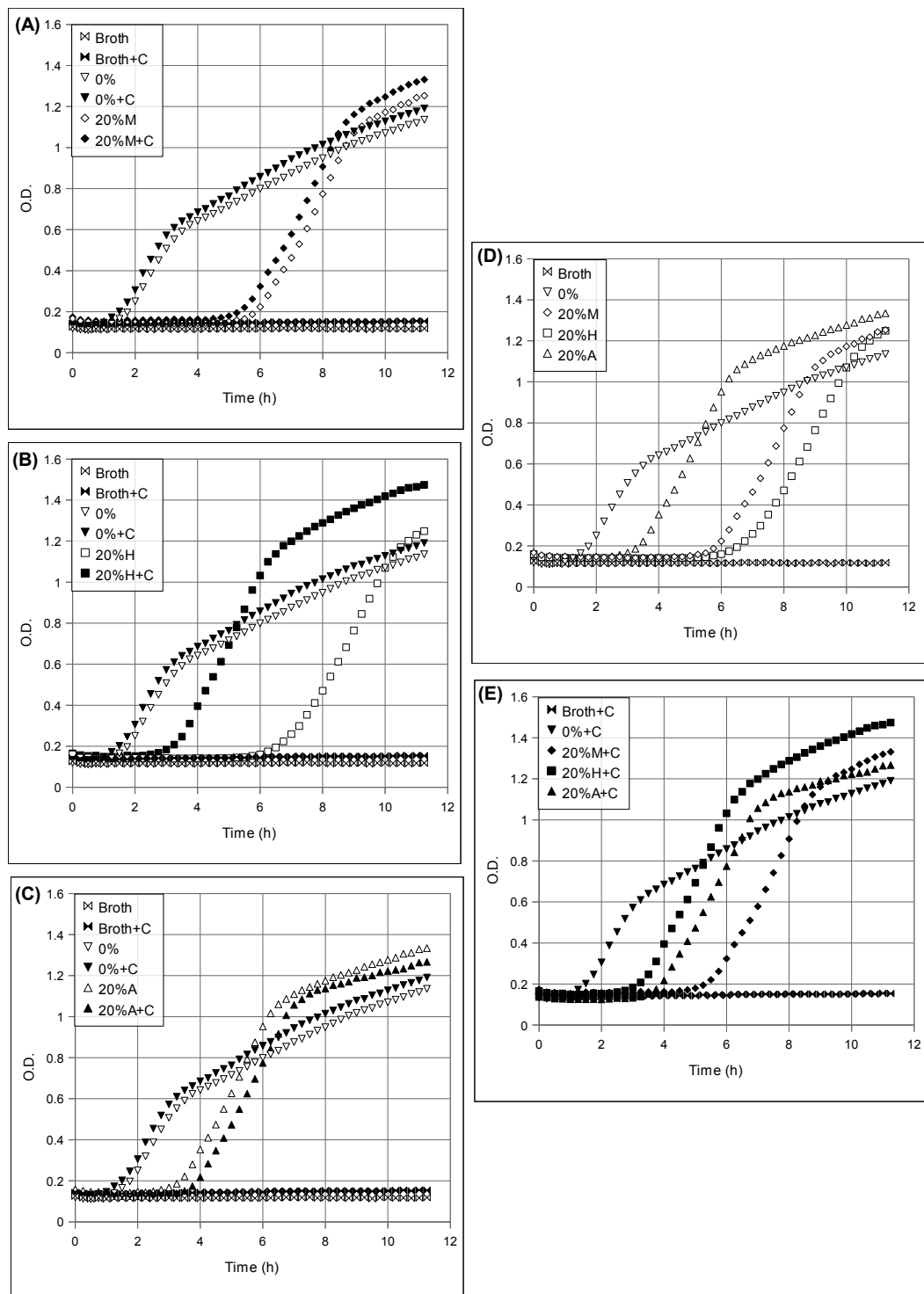

Figure 6.31: Growth curves monitored by a microtiterplate reader of *E. coli* culture after 1 hour exposure of 20% honey. Comparisons of the growth curves are made within subfigures (A): manuka honey M115, (B): honeydew honey, (C): artificial honey, (D): honeys without 0.1% catalase added, and (E): honeys with 0.1% catalase added. Abbreviations used in the keys: M, manuka honey M115; H, honeydew honey; A, artificial honey; C, catalase solution (0.1%).

bacterial cells (the exposure of cells to the honey, washing off etc.) were all the same, unless the way how the re-growth of bacteria was monitored would make any difference to the postantibiotic effect result. In fact, several alternatives based on bioluminescence, bacterial morphology, infrared spectroscopy, radiometry, fluorometry and others including spectrophotometry have been suggested (Nicolau, 2001). However, Rescott et al. (1988) also noticed a significant variation between the spectrophotometric method and the standard viable counting method when testing the effect of tobramycin on *E. coli* while the variations between the two methods when using ampicillin and ciprofloxacin were not statistically significant. Stubbings et al. (2004) compared the two methods using 22 antibiotics with 3 strains of *E. coli* and a strain of *S. aureus*, and concluded that bacteriolytic antibiotics gave poor correlation in the results obtained with the classical and spectrophotometric methods. It is also pointed out that other biological factors (cell phase, inoculum density, changes in bacterial morphology), and the machinery factor (growth detection threshold and incubating temperature) could cause deviation in the postantibiotic effect results (Domínguez et al., 2001). Indeed, a decline in the viable counting right after washing honey off was noticed in the traditional method whereas this is not reflected in the growth curves obtained spectrophotometrically in which all curves shared a common base line. Also it must not be forgotten that the optical density is related to the cell mass but not to the cell number, and whether or not honey made any alternation to the cell mass is not clear. Therefore, it might be unwise at this stage to compare the postantibiotic effect obtained from the two methods until the monitoring techniques are to be standardised.

Comparing the re-growth latency among the honeys with different concentration, on the other hand, revealed that the postantibiotic effect induced by honey in *E. coli* seems to be dependent on the concentration as well as the type of honey. At 5%, only manuka honey but not other types of

honey induced a postantibiotic effect. That postantibiotic effect can still be observed even if the pre-existing hydrogen peroxide was removed, despite it appearing from Figures 6.29, 6.30 and 6.31 that hydrogen peroxide also contributes to the postantibiotic effect in the total antibacterial activity in manuka honey. As the honey concentration rises to that above the MIC, it appears that all honey types including the sugar syrup are capable of inducing a postantibiotic effect in the species, although this is more significant in manuka honey and honeydew honey. However, although the postantibiotic effect induced by honeydew honey increases as its concentration rises, that latent phenomenon for it at concentrations of both 10% and 20% is reduced to the level of that equivalent to artificial honey once catalase is added in. This is understandable because hydrogen peroxide is the major antibacterial factor in honeydew honey, and osmolarity would be the only factor to cause a postantibiotic effect once the hydrogen peroxide activity is removed. Manuka honey, on the other hand, still can induce a postantibiotic effect after its hydrogen peroxide activity has been removed. Interestingly, neither the effect of hydrogen peroxide nor that of non-peroxide antibacterial components on the postantibiotic effect in manuka honey seems to be directly correlated with the honey concentration because the exact increase in postantibiotic effect from 5% to 10% and then to 20% is in fact decreasing if we subtract the postantibiotic effect by 20% artificial honey from other honey. This might suggest that each antibacterial factor in the honey (*i. e.* osmolarity, hydrogen peroxide and non-peroxide) may work differently depending on the honey concentration. Unfortunately the sample size is too limited in this trial to analyse the role which each antibacterial factor plays in the pharmacodynamic effect of manuka honey.

The mechanisms by which honey or antibacterial agents induce a postantibiotic effect in bacteria are poorly known, largely because alterations in morphology or metabolism are not uniform in microorganisms. Observation

using electron microscopy showed that some classes of antibiotics increased the number of crosswalls or the thickness of the cell wall in staphylococci, or induce intracellular electrodense aggregation in *P. aeruginosa* (Gottfredsson et al., 1993) and the release of intracellular components (Sakagami et al., 1999). Barmada et al. (1993) observed with *E. coli* that during the postantibiotic state the functional protein synthesis but not DNA and RNA synthesis was halted for 4 hours after tobramycin had been removed. Stubbings et al. (2006), on the other hand, reported that the gentamicin-induced postantibiotic effect on *E. coli* coincided with the recovery of protein synthesis whereas the one induced by rifampicin coincided also with DNA synthesis. The effects of a single antimicrobial agent on cell morphology can also vary dramatically with bacterial species. It was reported that *para*-aminobenzoic acid (PABA) could induce *E. cloacae* to produce filaments, and could elongate and thicken the peripheral cells of *P. aeruginosa*, while with *S. aureus* PABA increased overall cell wall thickness and thickened transverse cell walls (Richards et al., 1993). A single alteration in morphology such as DNA synthesis could also vary in opposite ways, so that in *E. coli* and *S. aureus* the synthesis was suppressed whereas this was relatively enhanced in Gram-negative bacilli (Gottfredsson et al., 1995). The differences in morphological alteration after exposure to various antimicrobial agents may suggest that there exist multiple mechanisms behind the postantibiotic effect. This might also apply to honey because of its complexity which is largely the result of various external factors, and that complexity could have had multiple effects on bacterial cells. However, more detailed research on the mechanism by which honey inhibits/kills bacteria is required to find if this is so.



THE EFFECT OF GASTROINTESTINAL ACIDITY AND  
ENZYMES ON THE ANTIBACTERIAL ACTIVITY OF  
MANUKA HONEY

---

In this chapter the effect of acidity and digestive enzymes on the antibacterial activity of manuka honey are described.

## 7.1 Introduction

Any ingested food would get into the colon through the stomach. At the same time, a large number of microorganisms can also be ingested: in addition to topical wounds, oral ingestion is thought to be the major “entrance” through which microorganisms can invade in a host. It is estimated that over  $10^{10}$  bacteria each day may enter the host through the mouth (Wilson, 2008), and therefore a defence system against these microbes is essential to maintain the host’s health.

In healthy individuals, before the food reaches the colon it is digested by the digestive system while passing through the tract. As it passes, the gastrointestinal tract secretes fluid with a range of functionality that helps degrade food ingredients into small molecules. The enzymes digest proteins, carbohydrates and lipids in the food. The gastric protease, pepsin, hydrolyses the amino-terminal side of the aromatic amino acids phenylalanine, tryptophan and tyrosine (Keil, 1992). The acidity, on the other hand, provides an optimum environment for the enzymes to react and also assists food degradation. Gastric digestion is then followed by intestinal digestion carried out by various enzymes such as trypsin, chymotrypsin, amylase and lipase, which work in association with bile salts. The pH in the chyme is spontaneously neutralised to approximately 7–8 by pancreatic fluid, so acidity no longer plays a role in digesting food in the intestine (Wilson, 2008).

The gastrointestinal environment also plays an essential role as a defence line in the body, of which the gastric acidity may contribute the major part of the antiseptic action. The acidity in the stomach (pH 2) prevents bacterial colonisation on gastro-epithelial cells and also eliminates the majority, if not all, of the invasive organisms (Wilson, 2008). It is estimated that the number of viable cells can decline from incoming  $10^{10}$  bacteria to less than

$10^3$  CFU/ml (Wilson, 2008), although this number can also rise up to  $10^5$ – $10^6$  depending on individuals and the time in a day, especially the time after a meal (Wilson, 2008). The significant rise in pH in the small intestine, however, decreases the potential to inhibit the growth of bacteria so that the viable cells could increase up to approximately  $10^{13}$ – $10^{14}$  in the large intestine (Wilson, 2008). In a simulated digestion study it was reported that *E. coli* O157:H7 and *S. flexneri* are inactivated significantly in simulated gastric fluid, with the inactivation rate decreased as the dose of antacid increased (Tamplin, 2005).

Gastric enzymes may also affect the bacterial cells. However, the short transit time in the stomach may make the antiseptic effect of pepsin less significant than that of acidity. Although the small intestine is believed to be the main part of the digestion in a host because of the long stay in the tract, the antimicrobial effect of intestinal enzymes is also not obvious as can be seen from a study done by Gorbach et al. (1967). They reported that the estimated colonisation in the gastrointestinal tract in 18 healthy individuals increased from less than 50 CFU/ml in the stomach to 50–100 CFU/ml in the duodenum, to 100–1 000 CFU/ml between the upper jejunum and the upper ileum, and this then abruptly increased to more than 500 000 CFU/ml in the distal ileum. This can be because the digestive enzymes together with bile acids are absorbed by the tract (Martini, 2001), but it can also be because the indigenous microbiota have adapted to the intestinal environment (Wilson, 2008).

The enzymic activity and the acidity of digestive fluid not only affects bacterial cells but may also affect the property of antimicrobial agents. In fact, several antibiotics have been reported to lose their stability or efficacy in the gastrointestinal environment, which is largely due to the acidity. An example is that amoxicillin and metronidazole appear to be stable at a normal gastric pH (1.0–2.0) whereas clarithromycin can be degraded at this

pH in about 4 hours (Erah et al., 1997), and some proton pump inhibitors are therefore administered to ensure the acid-susceptible drugs are not inactivated by the acid during *H. pylori* eradication therapy (Axon, 1991).

In honey, hydrogen peroxide is one of the major antibacterial factors and its production (Equation 1.1) can be affected by many factors including heat, light and acidity (Crane, 1979). It is reported that the enzyme glucose oxidase that catalyses the reaction in which hydrogen peroxide is formed works well at pH 7 whereas the activity, hence the accumulation of hydrogen peroxide, is negligible at pH 3 (Crane, 1979). Thus the gastric environment is obviously too acidic for the enzyme to produce hydrogen peroxide. Also, pepsin as well as other digestive enzymes and salts in the tract may destroy the enzyme and affect the non-peroxide antibacterial activity of manuka honey. Therefore it was necessary to investigate how well the activity of the honey would work when subjected to acidity and the enzymic factors. In this chapter, the influence of acidity and then that of gastrointestinal enzymes on the antibacterial activity of manuka honey is investigated.

## 7.2 The effect of acidity on the antibacterial activity of manuka honey

### 7.2.1 *Materials and method*

#### 7.2.1.1 Bacterial cultures and media

The bacterial cultures used in this study were: *E. coli*, *Shigella* spp., *P. aeruginosa*, *Salmonella* spp., *Enterobacter* spp., *Enterococcus* spp. and *Y. enterocolitica*. Mueller-Hinton broth (MHB) was used to cultivate the cultures. The cultural inocula were prepared as described in Chapter 4.

Before the study was carried out, it was considered to use buffered media to minimise the possible pH fluctuation due to the bacterial metabolism during the incubation. However, different buffer solutions have different optimum buffering capacity, and to cover the wide range of pH that would be used in this study (pH 2–8) it would be required to use media made up with different buffer solution for different pH range, and the different buffering acids and salts could also further influence the bacterial metabolisms and the activity of manuka honey. This would add more undesirable complexity in addition to the effect of acidity being studied. It is also reported that the pH of both inoculated and non-inoculated media do not fluctuate significantly during incubation unless it is anaerobically incubated for more than 24 hours (Jansen and Bremmelgaard, 1986). Therefore it was decided to make broth and honey solutions with various pH values by adjusting the pH with 1 M HCl or 1 M NaOH to minimise the possible variables involved.

It was also realised in a preliminary test that the range of the final concentration of honey in microplate wells, which is achievable by serially diluting a single initial concentration of honey with the dilution method used in Chapter 4, was too narrow to cover the possible MIC in this study (Table 4.1). For example, the detectable range of MIC is 2.23–16.6% if 50% honey solution is used, and it was found that all bacteria could grow in 16.6% alkaline honey whereas they could not survive in 2.23% acidified honey. Because a range of pH values (pH 2–8) was to be examined simultaneously, it was required to expand the range of the final concentration in microplate wells. Therefore a binary dilution method starting with honey of a high concentration (40%) was used in this study. The range of concentrations of honey prepared in this study was 0.156%, 0.312%, 0.625%, 1.25%, 2.5%, 5%, 10%, 20%, and 40%.

The manuka honey used was the medium activity M115. Artificial honey was also used to distinguish the antibacterial efficacy of honey at each pH from antibacterial activity caused by osmolarity.

For each pH tested, MHB and honey solutions of the same pH were prepared. Aliquots of single strength MHB with different pH values were prepared by adjusting the pH with HCl or NaOH. Aliquots of honey with different pH values were prepared by firstly making a double strength honey solution and adding an equivalent volume of double strength MHB, and then adjusting the pH with HCl or NaOH. All solutions were sterilised by filtering through a 0.22  $\mu\text{m}$  membrane.

To measure the MIC at each pH, the microdilution method was conducted, in triplicate, as described previously (Chapter 4). After the MIC test, the MBC for each condition was also examined as described previously (Chapter 4).

## **7.2.2 Results and discussion**

Figures 7.1–7.11 show the results of the susceptibility measurements with the various species at various pH values. Despite the wide interval between each concentration level, it is still obvious that generally there was a declining MIC and MBC as the environmental acidity increased. Most microorganisms failed to survive at a pH below 3 or 4 in the controls (no honey present). The presence of honey made no difference to survival at these pH values. The decline in MIC and MBC can be seen both in manuka honey and artificial honey, although the MIC and MBC values of artificial honey are significantly higher than those of manuka honey. Like what has been shown in previous chapters, this result shows that the osmolarity again is not practical.

It is possible that the antimicrobial activity provided by the unknown non-peroxide antimicrobial component itself is to some degree destroyed

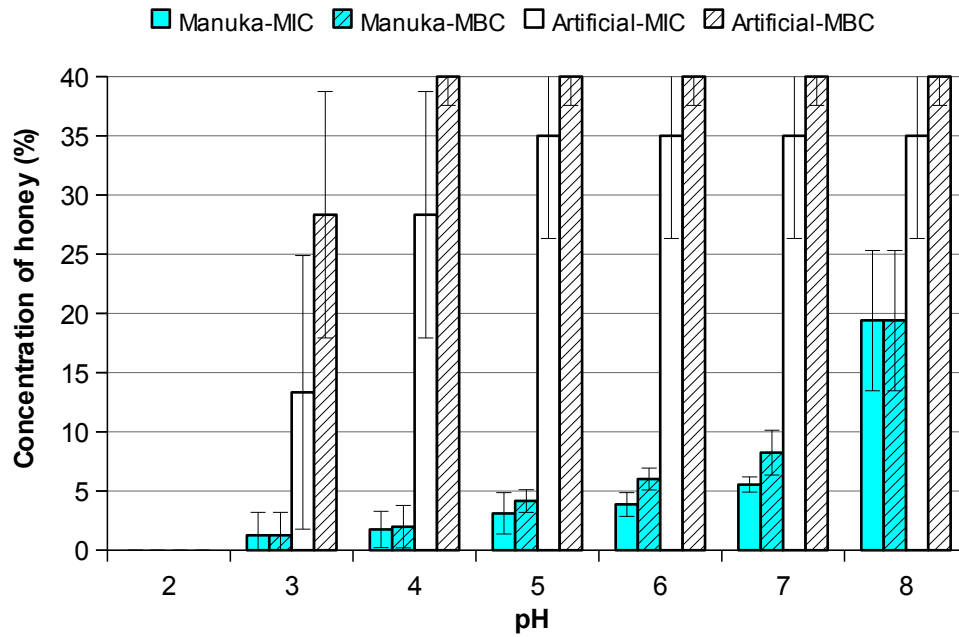

Figure 7.1: The effect of pH on the MIC and MBC of manuka honey M115 and artificial honey against *E. coli*. The results shown are mean values (n=3)  $\pm$  SD.

or inactivated by the acidity. The inhibitive effect of the acidity on the bacterial cells could have at the same time compensated for the loss of activity. However, if this was the case then the MIC and MBC of manuka

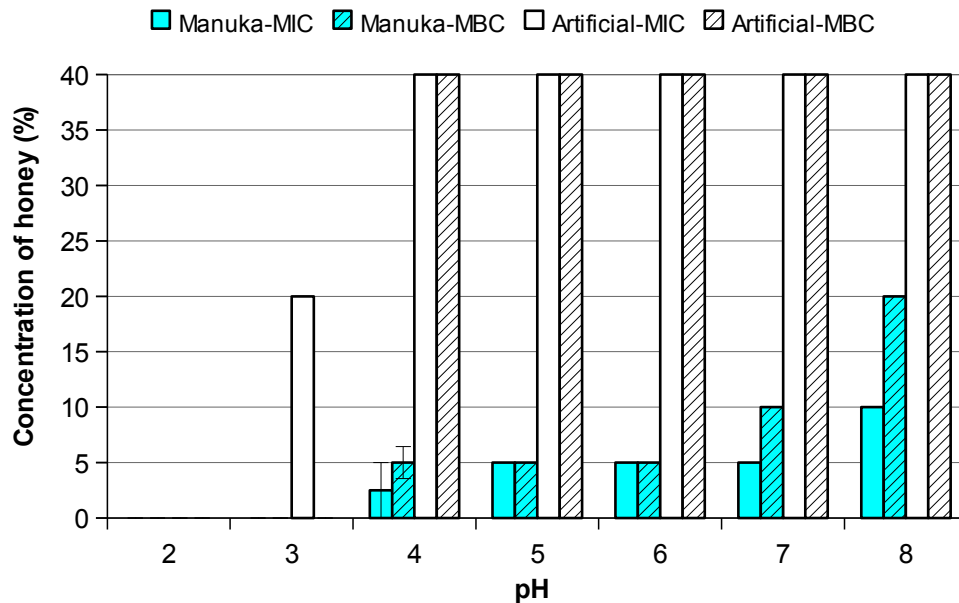

Figure 7.2: The effect of pH on the MIC and MBC of manuka honey M115 and artificial honey against *S. typhimurium* DT104. The results shown are mean values (n=3)  $\pm$  SD.

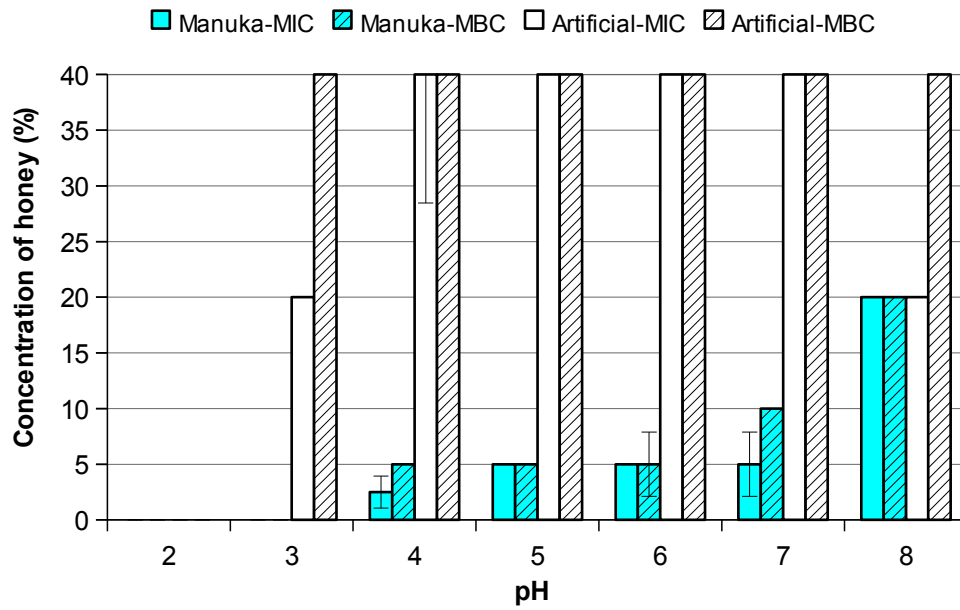

Figure 7.3: The effect of pH on the MIC and MBC of manuka honey M115 and artificial honey against *S. enteritidis*. The results shown are mean values ( $n=3$ )  $\pm$  SD.

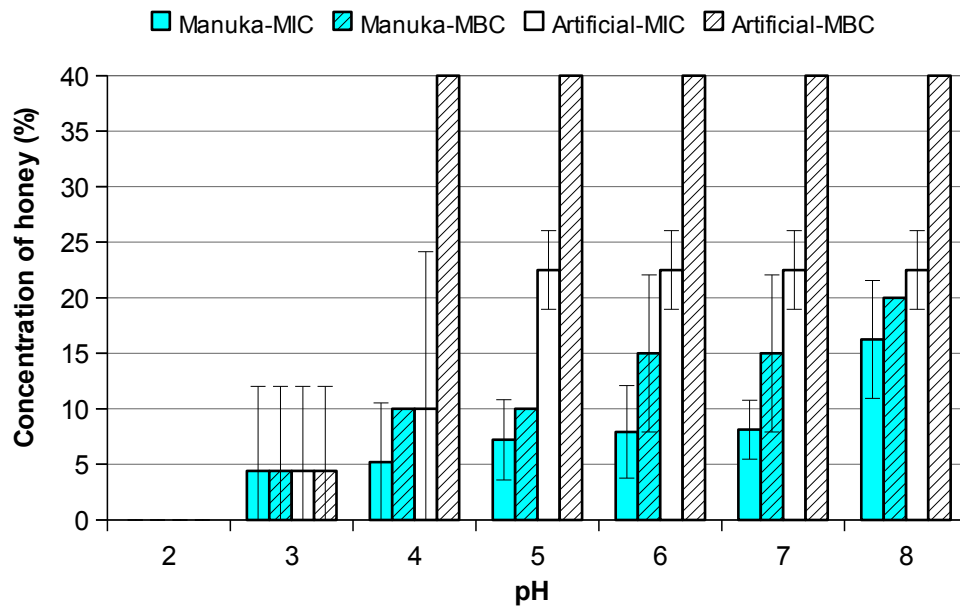

Figure 7.4: The effect of pH on the MIC and MBC of manuka honey M115 and artificial honey against *P. aeruginosa*. The results shown are mean values ( $n=3$ )  $\pm$  SD.



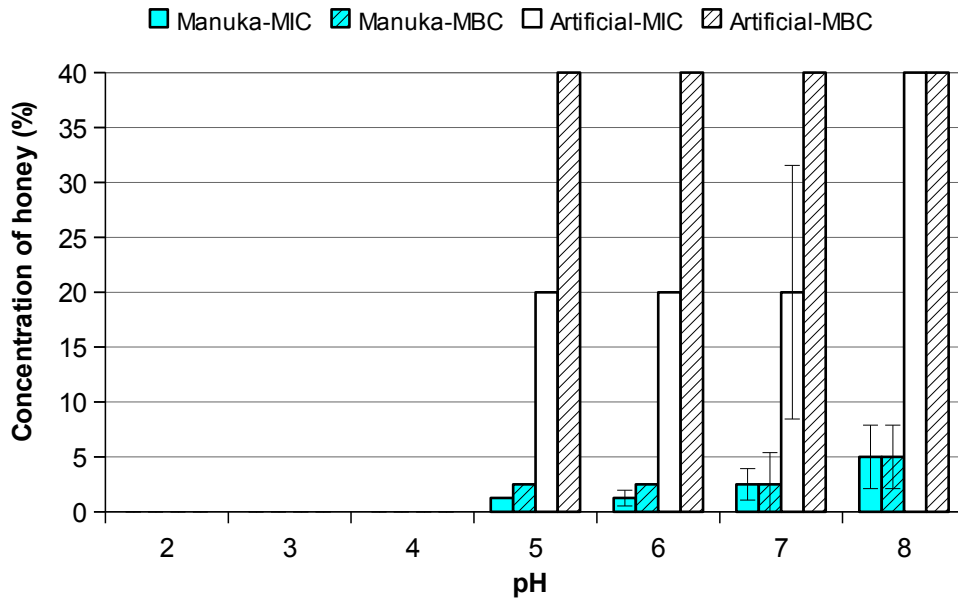

Figure 7.5: The effect of pH on the MIC and MBC of manuka honey M<sub>115</sub> and artificial honey against *Y. enterocolitica*. The results shown are mean values (n=3) ± SD.

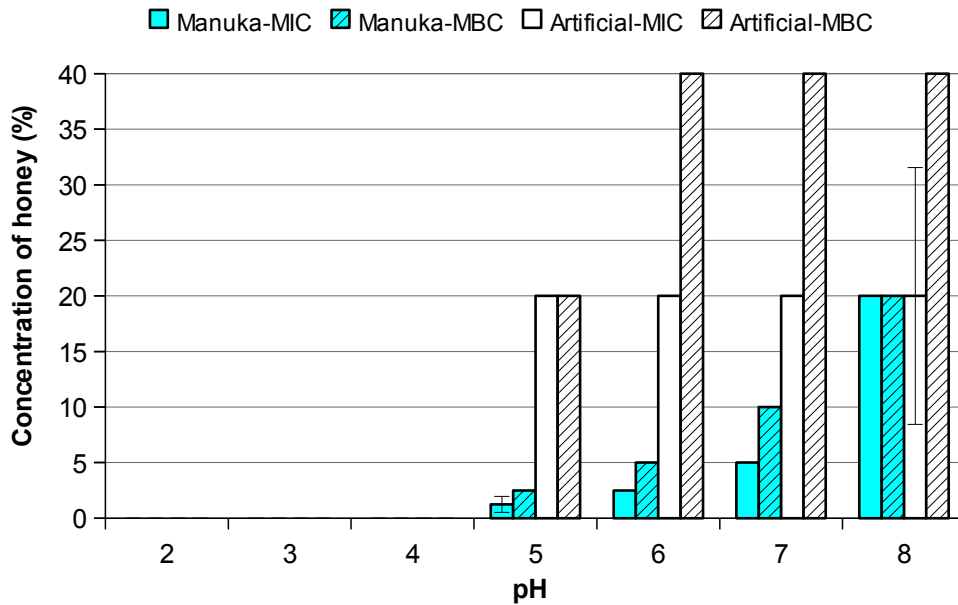

Figure 7.6: The effect of pH on the MIC and MBC of manuka honey M<sub>115</sub> and artificial honey against *S. flexneri*. The results shown are mean values (n=3) ± SD.

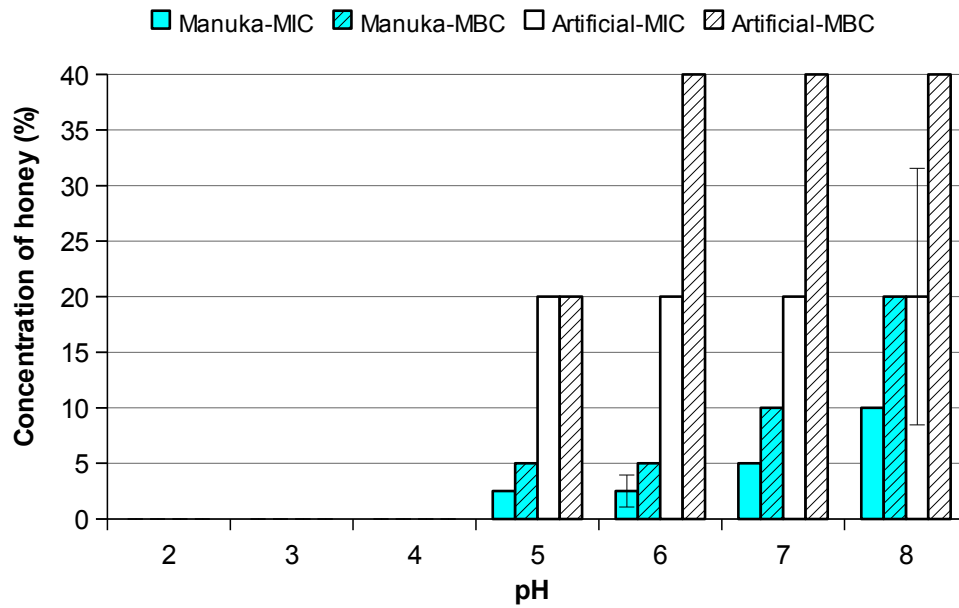

Figure 7.7: The effect of pH on the MIC and MBC of manuka honey M<sub>115</sub> and artificial honey against *S. sonnei*. The results shown are mean values (n=3)  $\pm$  SD.

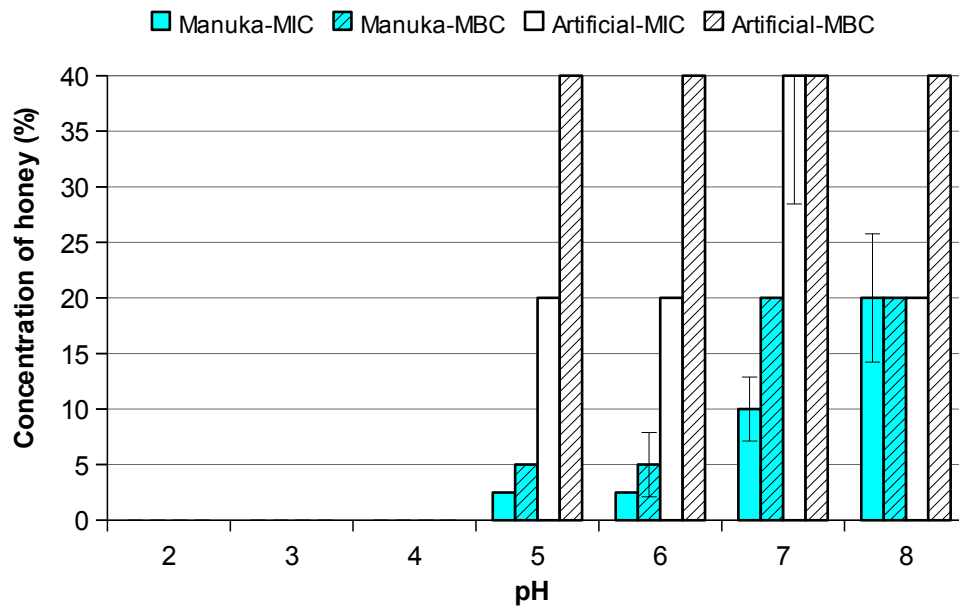

Figure 7.8: The effect of pH on the MIC and MBC of manuka honey M<sub>115</sub> and artificial honey against *E. aerogenes*. The results shown are mean values (n=3)  $\pm$  SD.

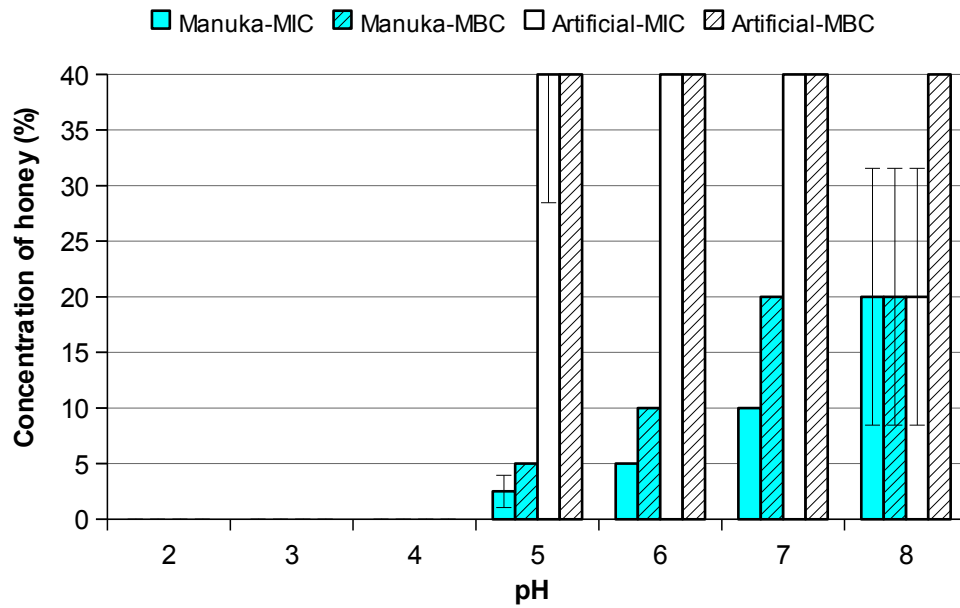

Figure 7.9: The effect of pH on the MIC and MBC of manuka honey M<sub>115</sub> and artificial honey against *E. cloacae*. The results shown are mean values (n=3)  $\pm$  SD.

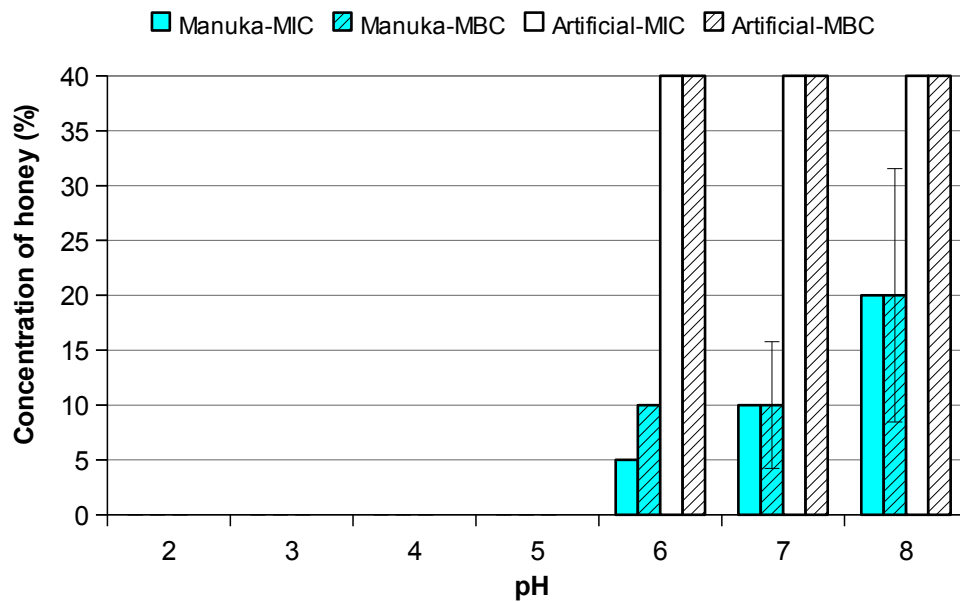

Figure 7.10: The effect of pH on the MIC and MBC of manuka honey M<sub>115</sub> and artificial honey against *E. faecalis*. The results shown are mean values (n=3)  $\pm$  SD.

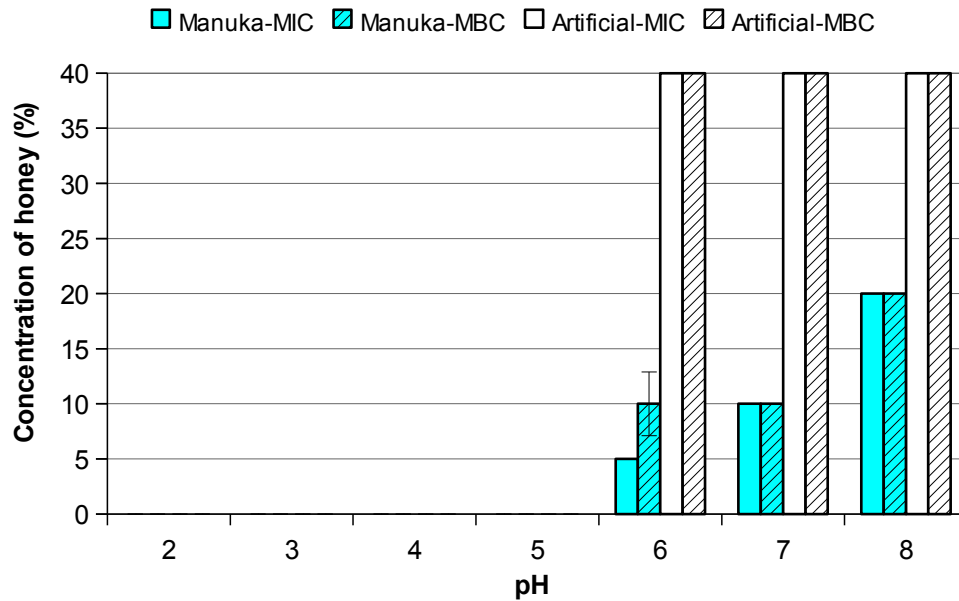

Figure 7.11: The effect of pH on the MIC and MBC of manuka honey M115 and artificial honey against *E. faecium*. The results shown are mean values ( $n=3$ )  $\pm$  SD.

honey at low pH should have been as high as that with artificial honey, but it was not. This indicates that, before the pH decreases to the level at which bacteria can not survive at all, the antimicrobial activity of manuka honey remains stable in acidic condition.

In contrast to the acidic conditions, the alkalic environment (pH above 7) seems to be slightly destructive to the antimicrobial activity in manuka honey, as seen in the remarkedly higher MIC and MBC values at pH 8 with manuka honey for all species of bacteria. The alteration in the antimicrobial activity in acidic and alkalic condition may possibly be partly caused by the decrease in activity of glucose oxidase that is responsible for the generation of hydrogen peroxide, as the activity of the glucose oxidase of honey is maximised at around pH 6.1 and declines as the pH moves toward the acidic and alkaline sides (Schepartz and Subers, 1964). In the study of Schepartz and Subers, the activity of glucose oxidase declined from 100% at pH 6 to approximately 40–50% at pH 8–9 or 20–30% at pH 2–3. Whilst acid may compensate the loss in the activity of the enzyme, pH 7–8 is in fact

preferable to many microorganisms and therefore the loss in the activity of glucose oxidase in such moderate alkaline environment could have also reflected on the MIC and MBC results. This suggests that the acidity itself can influence the antibacterial efficacy of honey. On the other hand, it is possible that the alkaline environment also has a negative effect on the non-peroxide components in manuka honey. [Snow and Manley-Harris \(2004\)](#) found using an agar diffusion assays that exposure to a range of alkaline pH caused the non-peroxide activity of manuka honey to be lost in less than 30 min (within 10 min, the honey lost 50%, 100% and 100% activity at pH 9, 10, and 11 respectively). The finding in the work in this chapter is in agreement with the work by [Adams et al. \(2008\)](#) in which treatment of manuka honey with NaOH and then titration back to the original pH resulted in irreversible loss of the non-peroxide antibacterial component in their HPLC assay. The lability of dicarbonyls, hence of methylglyoxal, in an alkaline environment has also been reported by [Bowden and Fabian \(2001\)](#). The increase in the MIC and MBC at pH 8, however, shows only a partial loss of activity because the efficacy is still greater than that of the artificial honey in the identical condition, suggesting that at pH 8 manuka honey still can inhibit microorganisms by means of peroxide or non-peroxide action in addition to osmolarity.

Acidity, especially that in the stomach, in comparison with other defence mechanisms in the gastrointestinal tract (*e. g.* enzymes, mucus, immunoglobulin), is the primary barrier in a host to defend against incoming bacteria ([Giannella et al., 1972, 1973](#)), and the failure in the growth of bacteria in the extreme pH as shown in this study may make humans feel that the importance of the antibacterial property of manuka honey is less obvious. One should not forget, however, that bacteria may break through the acid barrier because they may have adapted to the extreme pH before being ingested in the body. Many species of bacteria including gastrointestinally

important pathogens such as *E. coli*, *Shigella*, *V. cholerae*, *S. typhimurium* and *H. pylori* (Merrell and Camilli, 2002) have been reported to be able to tolerate extreme pH using many mechanisms, including altering membrane lipid composition (Yuk and Marshall, 2004) or proteins (Leyer and Johnson, 1993), or through numerous pH-influenced gene regulations (Hall et al., 1995). Such acid or alkaline adaptation can be induced by exposing the cells in mildly acidic or alkaline conditions for one to two cell-doubling generations. As such mild environmental stress can easily be found in food or food processing, bacteria causing food-borne gastroenteritis in fact may have been able to tolerate acid/alkaline stress, and consequently the acidity in the stomach or intestinal tract may be less effective against these adapted bacteria. In this respect, the antibacterial activity of manuka honey may be of additional help to the gastrointestinal defence system.

Whereas bacteria adapted to acidic conditions would be tolerant to a yet more extreme environment, at the same time they can also be more sensitive to other types of environmental stress. *E. faecalis* that is pre-incubated at pH 10.8 can subsequently tolerate pH 11.9 but not pH 3.2 (Flahaut et al., 1997). In the same study, the same species exposed to pH 4.8 was found to survive at pH 3.2 but not at pH 11.9 (Flahaut et al., 1997). A similar phenomenon can also be observed with *E. coli* (Rowbury et al., 1993; Rowbury and Hussain, 1996). As acidic/alkaline (and, in fact, many other environments) stress responses involves various mechanisms, one adaptation could lead the cells to be adversely more sensitive to other stress. Similarly, cells of the same species with and without adaptation to acidic/alkaline environment may differ in the sensitivity to manuka honey. As in this study the bacterial cultures were prepared in neutral Mueller-Hinton broth (pH 7.4) before the sensitivity test was carried out, it would not be surprising if the efficacy of manuka honey in acidic/alkaline environment *in vivo* happen to vary from this *in vitro* study, and of course it would also be of interest to investigate

the sensitivity of the acid/alkaline adapted strains to manuka honey in the future.

### 7.3 The effect of gastrointestinal enzymes on the activity of manuka honey

Following study of the effect of pH on the total antimicrobial activity of manuka honey, the effect of gastrointestinal enzymes on the honey was investigated. It has been reported that glucose oxidase from *Aspergillus niger* and *Penicillium notatum* is stable against pepsin (Stecher et al., 1968) and an acidic environment, however the activity was lost completely at pH 1 (Keilin and Hartree, 1948). However, it is not known whether or not the glucose oxidase of honey has the same stability as that of fungal glucose oxidase. If there were any difference in the result of the sensitivity test to be carried out in this section, that could be either because the bacterial cells are digested or damaged by the proteinases, or because the enzymes responsible for total and non-peroxide antibacterial activities in manuka honey are affected by the proteinases through an unknown mechanism.

To simulate the gastric and intestinal environments, simulated gastric fluid (SGF) (Rockville, 1990a) and simulated intestinal fluid (SIF) (Rockville, 1990b) were used in this section.

Whereas bile salt is not an enzyme, nor is it included in the simulated intestinal fluid formula in the United States Pharmacopeia (Rockville, 1990b), bile was also used in the study to evaluate whether or not bile would affect the overall antibacterial activity of the honey. This decision was based on two reasons. One was that bile is secreted into the intestine. The other was it has been reported that bile appears to have antibacterial activity against some microorganisms (Begley et al., 2005; Hanninen, 1991) and therefore

bile, together with the other proteinases, could assist the antibacterial action of the honey.

### 7.3.1 *Materials and method*

The bacterial species used and the preparation of inoculum were the same as in Section 7.2.

Only manuka honey (M115) was tested because it had been clear in the previous section that a very high concentration of artificial honey would be required to treat gastrointestinal bacteria even if an acidic environment was to be conducted in this test. The sensitivity test was conducted and analysed with the microdilution method, with repeats to give a total of 5 times, as described in Chapter 4, with an exception that 0.1 volume of gastrointestinal enzyme solution was added in serially diluted honey solution before standardised inoculum was added.

To make simulated gastric fluid (SGF), 3.2 g pepsin (pepsin A from porcine gastric mucosa; SIGMA Cat. No. P7000-25G), 2.0 g NaCl and 7.0 ml concentrated HCl were dissolved in purified water, then more water was added to make up 1 litre (Rockville, 1990b). This had a pH of 1.2 and was stored at 4°C until used (within 7 days).

Because it was found that pancreatin only partially dissolved in water, the amount of pancreatin in the simulated intestinal fluid (SIF) used in the work in this chapter was reduced to one tenth of that suggested in the US Pharmacopoea (Rockville, 1990b). To make simulated intestinal fluid SIF, 6.8 g  $\text{KH}_2\text{PO}_4$  was dissolved in 250 ml purified water and then to this 190 ml 0.2N NaOH, 400 ml water and 1.0 g pancreatin (from porcine pancreas; AppliChem Cat. No. A0585,0100) were added. After this it was adjusted to pH  $7.5 \pm 0.1$  with 0.2N NaOH and then purified water was added to make it



up to 1 litre (Rockville, 1990b). This was stored at 4°C until used (within 7 days).

Bile solution (3%) was made by dissolving 0.3 g bile powder (Sigma Cat. No. B-8381; bile from bovine, minimum 50% bile acid) in 10 ml purified water. Simulated intestinal fluid with bile was made by mixing 0.3 g of bile powder in 10 ml of SIF. A denatured intestinal fluid (heated in boiling water for 10 min then chilled in ice) with bile was also included in the test to investigate whether it was an enzymatic or chemical effect should pancreatin be found to have any influence on the MIC.

Seven different environments as listed in Table 7.1 were studied simultaneously. The honey solution was serially diluted first with MHB in sterile bijoux bottles and inoculated with bacterial culture as described previously in Chapter 4 (Section 4.2.5 on Page 90) except that the volumes were ten times greater than those described in Chapter 4. From each bijou 90 µl of serially diluted honey solution was transferred into microplate wells, then 10 µl of the other components were added, immediately before the microplate was monitored at 37°C overnight using a microplate reader to determine the MIC. To make the decrease in the final concentration of honey the same in all testing environments, 0.1 volume of sterilised water was also added in environments 1 and 2 as controls. The MBC was determined as described in Chapter 4.

The effect of the seven environments on the efficacy of manuka honey was analysed by the Kruskal-Wallis rank sum test and the pairwise t-test (with *P*-value adjusted with the Holm method) in the statistical package R (<http://www.r-project.org>) (R Development Core Team, 2008).

Table 7.1: The environments for evaluating the effect of intestinal enzyme on honey. Note that 0.1% and 0.3% respectively refer to the final concentration of pancreatin and bile after these components had been added in serially diluted honey.

Environment	Honey solution (90 $\mu$ l)	Pancreatin/bile addition (10 $\mu$ l)	Actual concentration
1	Culture, normal MHB, normal honey	H <sub>2</sub> O	
2	Culture, pH 7.5 MHB, pH 7.5 honey	pH 7.5 H <sub>2</sub> O	
3	Culture, pH 7.5 MHB, pH 7.5 honey	1% pancreatin	0.1% pancreatin
4	Culture, pH 7.5 MHB, pH 7.5 honey	3% bile	0.3% bile
5	Culture, pH 7.5 MHB, pH 7.5 honey	2% pancreatin and 6% bile mixture (1:1)	0.1% pancreatin, 0.3% bile
6	Culture, pH 7.5 MHB, pH 7.5 honey	1% boiled-pancreatin	0.1% boiled pancreatin
7	Culture, pH 7.5 MHB, pH 7.5 honey	2% boiled-pancreatin and 6% bile mixture (1:1)	0.1% boiled pancreatin, 0.3% bile

### 7.3.2 *Results and discussions*

In the test associated with simulated gastric fluid (SGF) which includes pepsin and extremely high acidity, all organisms failed to survive even in the positive control without honey and pepsin. This is in fact predictable as SGF had a pH of 1.2 whereas most microorganisms are known to lose their viability at pH below 4 or 5 as shown in Section 7.2. To understand the effect of the gastric enzyme on the efficacy of the honey, it would be of benefit to use microorganisms such as *H. pylori* that are capable of tolerating an acidic condition. Unfortunately it was not possible to test *H. pylori* in this study due to the difficulty of culturing that species. Also to be noted is that *H. pylori* survives the acidic conditions in the stomach by secreting the enzyme urease to hydrolyse urea in the gastric mucosa and create a less acidic micro-environment which may be at a pH at which manuka honey is known to work. Because of the urease activity of this species, it would be somewhat misleading to denote this testing model as to determine the effect of acidic conditions on the antibacterial activity in manuka honey. Alternatively, possible solutions to investigate the effect of pepsin would be to reduce the time for which bacteria are exposed to the simulated gastric fluid. However, it would be difficult to predict how long the antibacterial component, especially non-peroxide component, would be staying in the stomach, because any fluid like honey solution would promptly pass through the gut whereas it is not known whether or not the non-peroxide components would persist in the gastric mucosa or epithelial tissue. Another challenge that can be foreseen is that, if an organism is to be treated with gastric fluid followed by being transferred to a solid medium, the sudden fluctuation in the environmental pH would corrupt the cells (Reddy et al., 2007) which would consequently influence the results.

Perhaps the best way to assess the effect of pepsin would be to investigate from the viewpoint of the mechanism of antimicrobial action of manuka honey. Hydrogen peroxide is unlikely to be relevant to pepsin because although glucose oxidase would not be destroyed by pepsin (Stecher *et al.*, 1968), the pH required for pepsin to react is too low for glucose oxidase to generate peroxide action. On the other hand, the mechanism of the non-peroxide activity in the honey is not thoroughly understood at this stage.

Figures 7.12–7.22 show the MIC and MBC values of manuka honey in the various digestive environments with each species of bacteria. The MBC values are generally slightly higher than the MIC for all groups (*i. e.* 1–2 dilution steps different from the MIC). Kruskal-Wallis analysis showed that the enzymatic environments statistically affect both MIC and MBC values ( $P < 0.05$ ). The adjusted pair-wise analyses showed that the results of environments 3 and 5 are statistically higher than that of environment 1 ( $P < 0.05$ ). Overall, however, 10–15% manuka honey under intestinal digestive conditions was still capable of inhibiting the growth of most gastrointestinal bacteria. Comparing the MIC of manuka honey with and without pancreatin or bile being added (environments 1 and 2 *cf.* environments 3–5), it is seen that the addition of the intestinal components can negatively affect the efficacy of manuka honey.

Interestingly, although there was variation in the degree of fluctuation, most tested species revealed a similar trend in that the addition of either pancreatin or bile raised the MIC readings (environments 3 and 4). The increase in MIC is more significant when pancreatin and bile were added simultaneously (environment 5) ( $P < 0.05$ ). More interestingly, for most tested species, the degree of increase in the MIC when both pancreatin and bile were present (*i. e.* the difference between the MIC of environments 5 and 2) is almost identical to the sum of the degree of the increase due

to the individual components (*i.e.* the sum of “the difference between environments 3 and 2” and “that between 4 and 2”), suggesting that the influences of pancreatin and bile are probably additive.

Heated pancreatin (environments 6 and 7) did not decrease the activity of manuka honey as great an effect as unheated pancreatin ( $P > 0.05$ ), suggesting that denatured pancreatin can less likely affect the efficacy of the honey negatively. This also indicates that pancreatin can influence the antimicrobial activity of manuka honey enzymatically. Perhaps this is approached by destroying proteins that are responsible for the antibacterial activity of the honey. This hypothesis, however, will need to be proved in future by investigating the stability of proteins in honey against enzymes.

Whilst the antimicrobial activity of manuka honey still works in the simulated intestinal environment, it is still somewhat surprising to note that intestinal enzymes slightly reduced the activity of the honey, and especially that bile seem to have an additive effect on the reduction. The reduction in the activity may partially be due to the environmental pH which is slightly

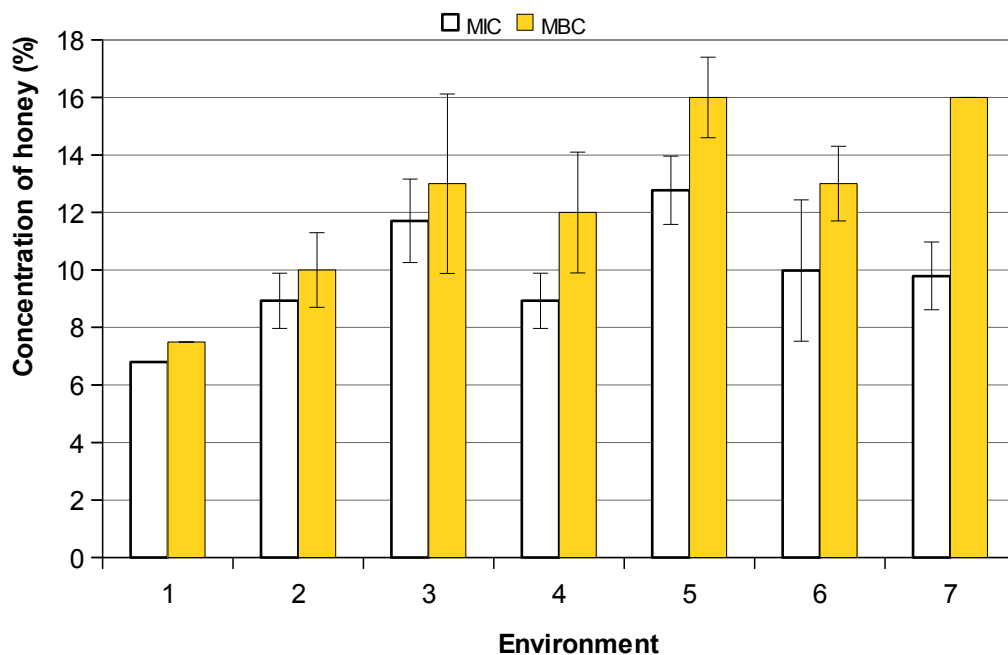

Figure 7.12: Comparison of the MIC and MBC of manuka honey M115 against *E. coli* in various digestive environments. The results shown are mean values ( $n=3$ )  $\pm$  SD. The seven environments are described in Table 7.1.

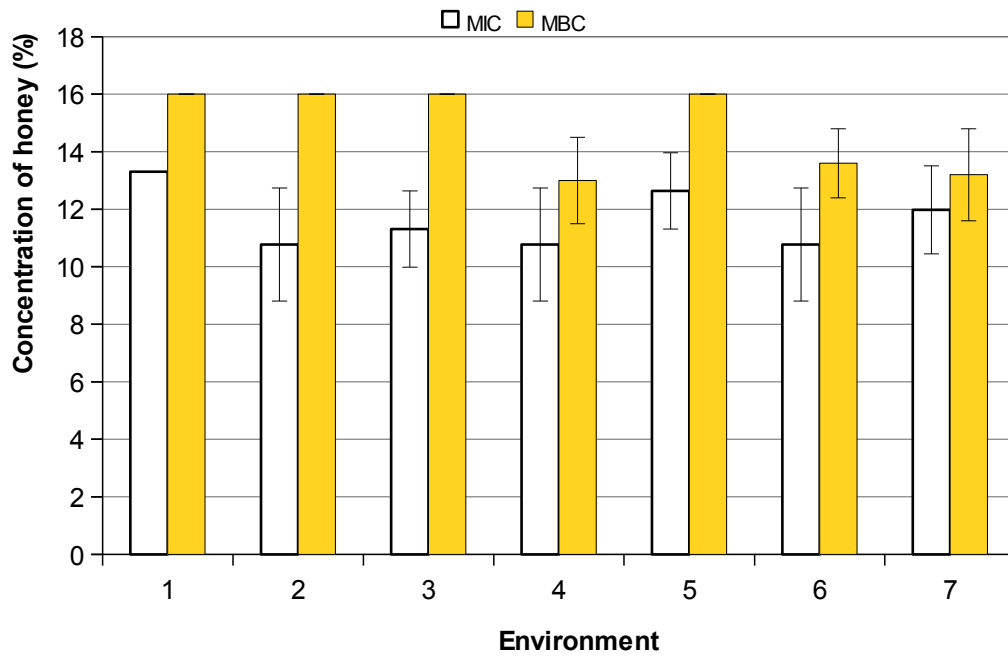

Figure 7.13: Comparison of the MIC and MBC of manuka honey M115 against *P. aeruginosa* in various digestive environments. The results shown are mean values (n=3)  $\pm$  SD. The seven environments are described in Table 7.1.

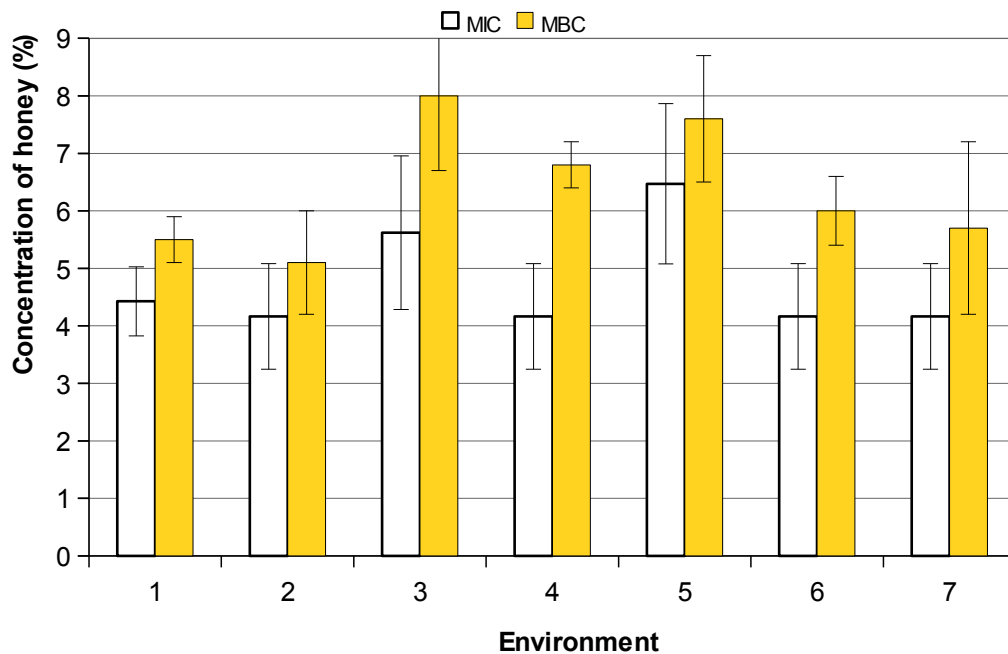

Figure 7.14: Comparison of the MIC and MBC of manuka honey M115 against *Y. enterocolitica* in various digestive environments. The results shown are mean values (n=3)  $\pm$  SD. The seven environments are described in Table 7.1.

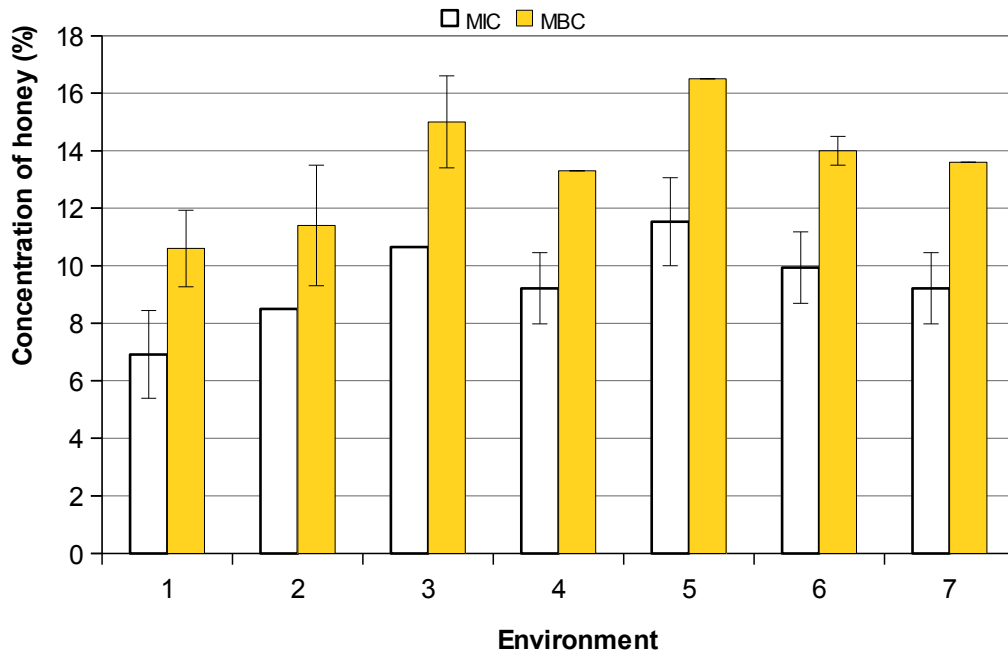

Figure 7.15: Comparison of the MIC and MBC of manuka honey M115 against *S. typhimurium* DT104 in various digestive environments. The results shown are mean values ( $n=3$ )  $\pm$  SD. The seven environments are described in Table 7.1.

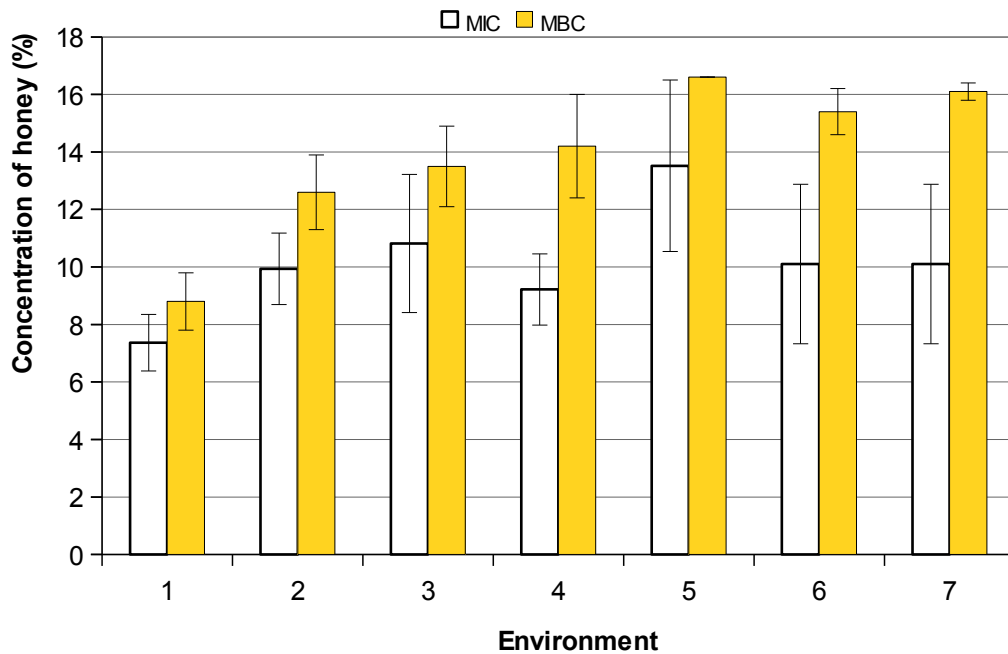

Figure 7.16: Comparison of the MIC and MBC of manuka honey M115 against *S. enteritidis* in various digestive environments. The results shown are mean values ( $n=3$ )  $\pm$  SD. The seven environments are described in Table 7.1.

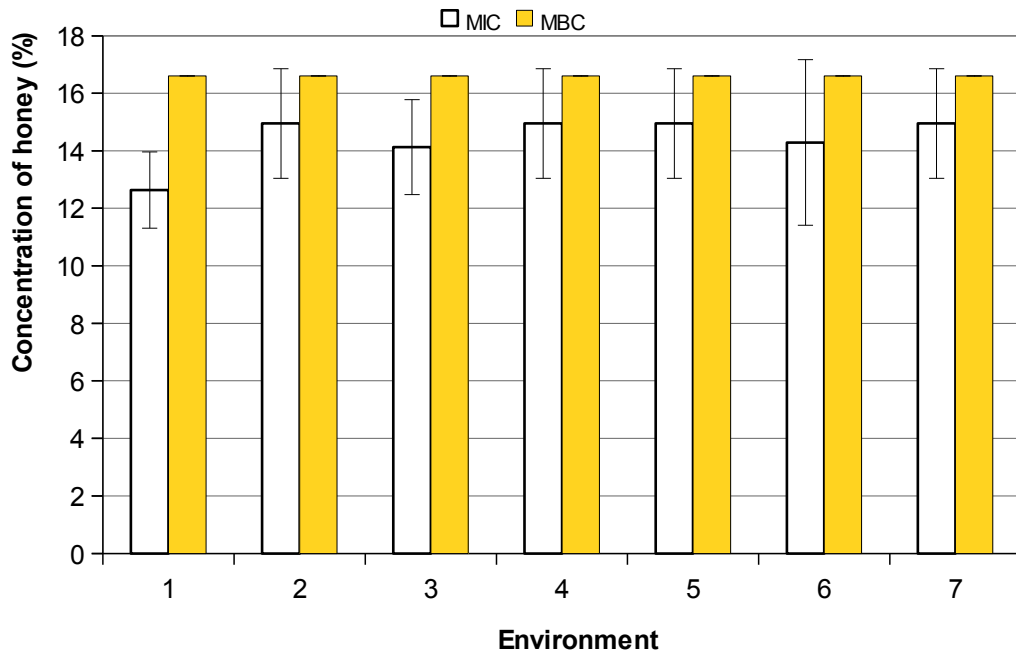

Figure 7.17: Comparison of the MIC and MBC of manuka honey M115 against *E. faecalis* in various digestive environments. The results shown are mean values ( $n=3$ )  $\pm$  SD. The seven environments are described in Table 7.1.

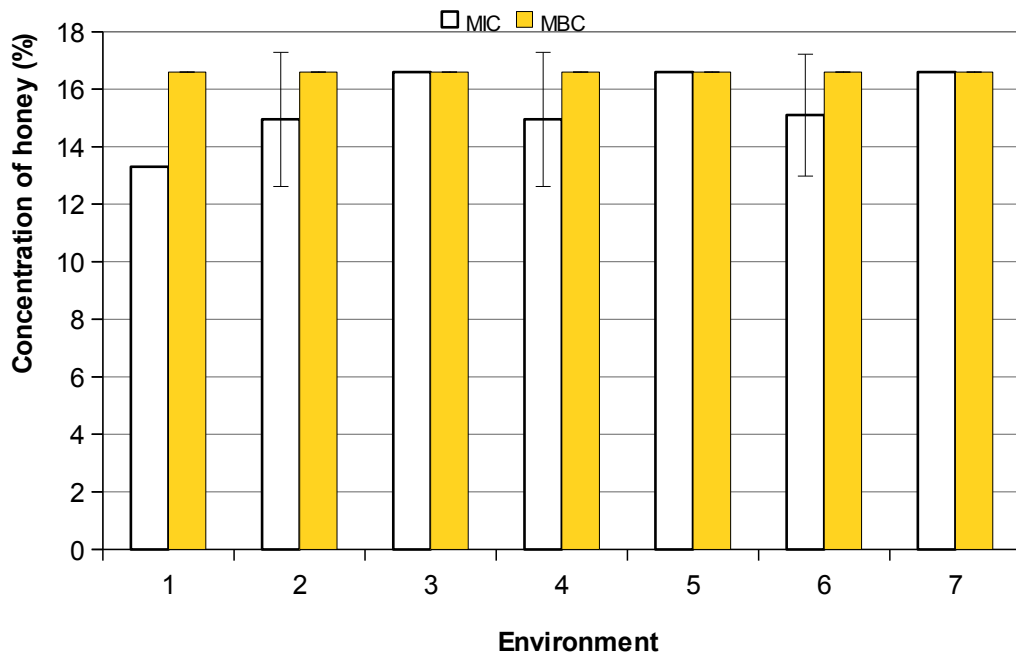

Figure 7.18: Comparison of the MIC and MBC of manuka honey M115 against *E. faecium* in various digestive environments. The results shown are mean values ( $n=3$ )  $\pm$  SD. The seven environments are described in Table 7.1.



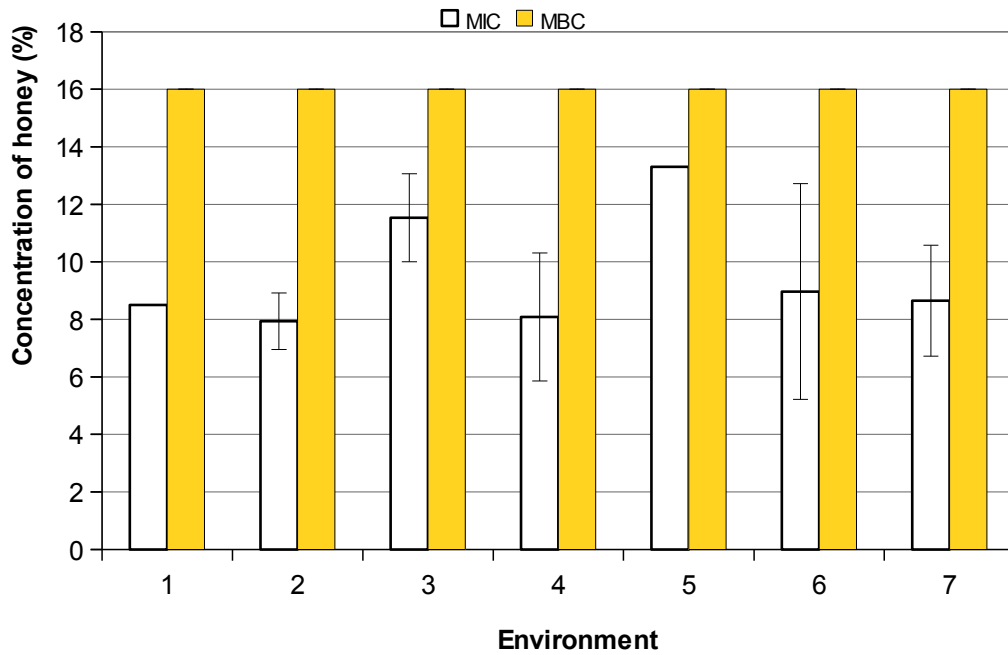

Figure 7.19: Comparison of the MIC and MBC of manuka honey M115 against *E. aerogenes* in various digestive environments. The results shown are mean values ( $n=3$ )  $\pm$  SD. The seven environments are described in Table 7.1.

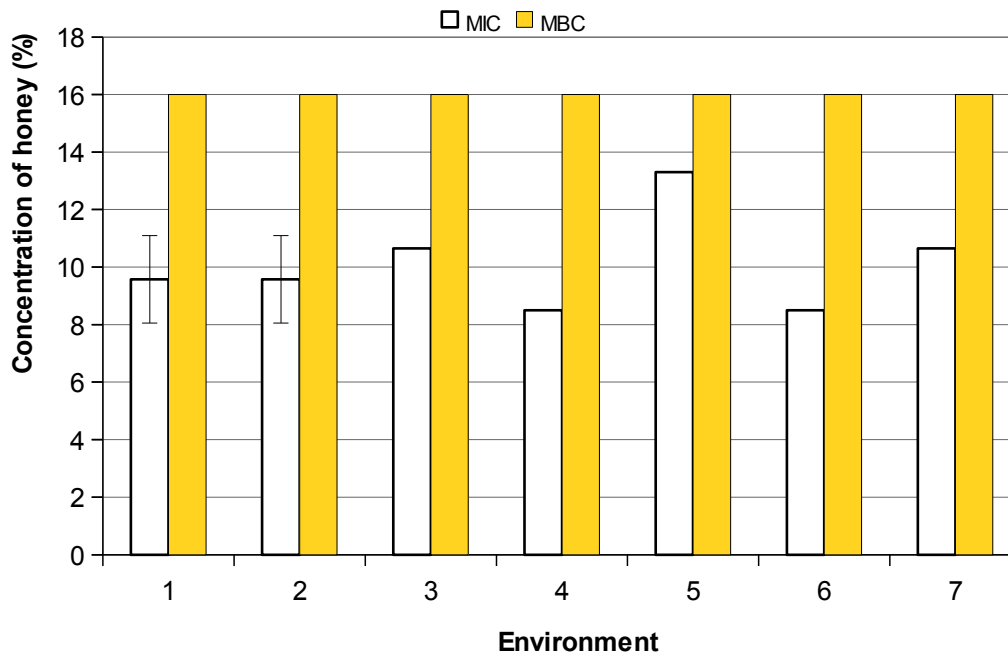

Figure 7.20: Comparison of the MIC and MBC of manuka honey M115 against *E. cloacae* in various digestive environments. The results shown are mean values ( $n=3$ )  $\pm$  SD. The seven environments are described in Table 7.1.

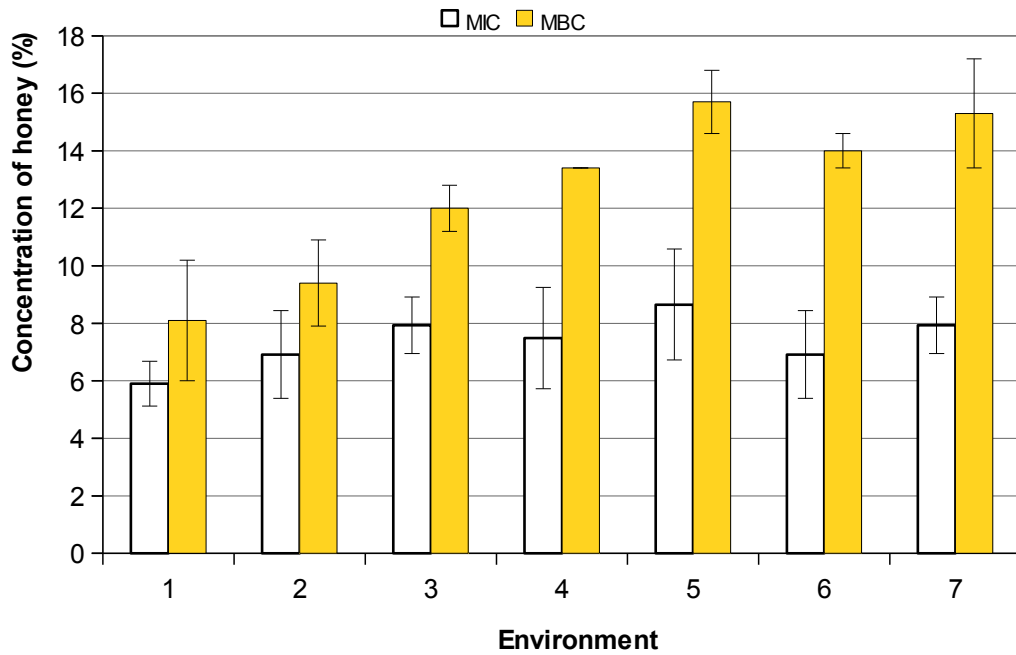

Figure 7.21: Comparison of the MIC and MBC of manuka honey M115 against *S. flexneri* in various digestive environments. The results shown are mean values ( $n=3$ )  $\pm$  SD. The seven environments are described in Table 7.1.

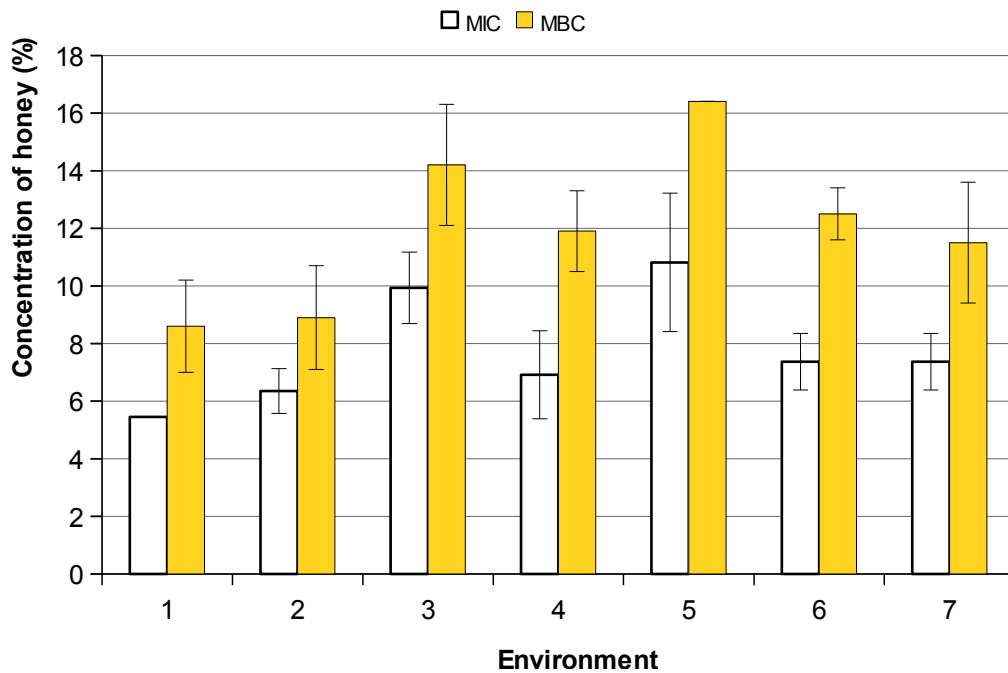

Figure 7.22: Comparison of the MIC and MBC of manuka honey M115 against *S. sonnei* in various digestive environments. The results shown are mean values ( $n=3$ )  $\pm$  SD. The seven environments are described in Table 7.1.

more alkaline than the regular testing environment, but since pancreatin is a mixture of catalytic enzymes including protease (trypsin) produced by the exocrine cells of the pancreas, the proteolytic enzyme could also have some membrane damaging effects on the bacterial cells, which in theory should have resulted in a decrease in the MIC values. The role of pancreatin in pathogenesis is not well known and the research is limited. [Paramithiotis et al. \(2006\)](#) assessed the survival of *Staphylococcus* spp. in the gastrointestinal tract and found the isolates to be resistant to pancreatin. On the other hand [Chaignon et al. \(2007\)](#) tested the susceptibility of staphylococcal biofilms to gastrointestinal enzymatic treatment and found that the eradication depends on the constituents and the clinical isolates. As the biofilm form of growth protects organisms from the hosts' immune systems and also from antimicrobial therapy, the disintegration of the biofilm matrix from the hosts' epithelial cell surface into the environment may help antibiotics to eliminate the bacteria. It is thought that it is this detaching function, rather than causing damage to the bacterial cells, is the way pancreatin and probably pepsin too, helps the host to defeat the bacterial infection.

Unlike the limited reports on pancreatin, a number of studies regarding the interaction between bile and bacteria have been done and antimicrobial activity of bile has been reported.

The major function of bile *in vivo* is to act as a biological detergent which emulsifies fats in the intestine. This suggests that bile has the potential for antimicrobial activity by disrupting cell membranes which may be more effective to Gram-negative than to Gram-positive bacteria due to the difference in the structure of their cell membranes. Other antimicrobial actions of bile that have been suggested are: disturbing macromolecule stability, inducing secondary structure formation in RNA, inducing DNA damage, altering the conformation of proteins resulting in misfolding or denaturation, causing oxidative stress by generating oxygen free radicals

and chelating calcium and iron (Bernstein et al., 1999; Kandell and Bernstein, 1991; Payne et al., 1998; Rajagopalan and Lindenbaum, 1982, 1984; Sanyal et al., 1991; Schmidt and Zink, 2000).

The type of the bile used may affect the inhibitory effect of bile to bacterial cells. Grill et al. (2000) reported that bovine bile that contains trihydroxyconjugated bile salts, was less inhibitory to bacterial cells than porcine bile, which contains dihydroxyconjugated bile salts. However, Begley et al. (2005) suggested that although bovine bile is commonly chosen to assess the tolerance of bacteria to bile, porcine bile would be more appropriate to use as it has more similar salt/cholesterol, phospholipid/cholesterol and glycine/taurine ratios to human bile. It is unknown if the constituents of bile would interact with the major antimicrobial ingredient of manuka honey. It is expected that the overall antimicrobial activity of manuka honey with porcine or human bile would be higher than that obtained in this study as human bile is more likely to provide inhibition of the bacterial strains. However, this hypothesis needs to be explored with human bile in future.

Despite of the number of report showing the deleterious effect of bile on cells, many microorganisms have been found to be resistant to bile. It is believed that Gram-positive bacteria are generally more sensitive to bile than Gram-negative bacteria, and therefore bile salt is usually used as a selective agent in media such as MacConkey medium, *Salmonella-Shigella* medium and esculin bile agar. The MIC and MBC values of bile reported for Gram-negative bacteria are generally substantially higher than those for Gram-positive bacteria (Drion et al., 1988; van Velkinburgh and Gunn, 1999), but some Gram-positive bacteria seem to be resistant to bile too. Brook (1989), Carpenter (1998), Flores et al. (2003) and Saito et al. (2003) reported that *Enterococcus* spp. may be isolated from bile or biliary drain devices. Since bacteria may survive on biliary drain devices where the concentration

of bile is very high, the fact that the species of bacteria in the study in this thesis are not killed by the addition of 0.3% bile would not be unexpected.

A possible explanation for the observation that the organisms were more resistant to the honey when bile (and perhaps pancreatin too) were present was the induction of adaptation. This is a phenomenon commonly seen among bacteria that a short-term pre-exposure of bacterial cells to sublethal levels of stress may induce the cells to adapt to the subsequent normal level of the stress, and as many stresses may have similar effects on the cells, an adaptation may also mean they adapt to other stresses at the same time. This is also termed “cross-adaptation” (Flahaut et al., 1997; Jenkins et al., 1988; Jones et al., 1993; Leyer and Johnson, 1993; O’Driscoll et al., 1996; Tompkins et al., 1994; Yuk and Marshall, 2004). Begley et al. (2005) noted that low levels of bile may rapidly intercalate with membrane lipids after solubilising them, which results in an increase in the resistance to further stresses. It is possible that this cross-protection caused manuka honey to be less effective in the simulated intestinal environment.

It must be emphasised that the bacterial growth, the effect of gastrointestinal enzymes and the antimicrobial action of manuka honey cannot be fully modelled from *in vitro* studies, because of the complex nature of the gastrointestinal environment that cannot be fully simulated in a laboratory. Microorganisms can alter their morphologies and genetic expressions in response to environmental stress, and the regulation can differ greatly even from strain to strain. It has also been shown in an *E. coli* macroarrays assay that manuka honey can upregulate genes that involve in stress responses, and downregulate those involved in protein synthesis (Blair et al., 2009). What has made the puzzle even more complex is that, unlike most antibiotics for which the chemical composition and the mechanisms of action are understood, there are still numerous of aspects in manuka honey that

remain to be cleared. These difficulties also apply to other gastrointestinal environment factors described in previous chapters.

## 7.4 Conclusion

Despite acidity and intestinal enzymes being able to negatively affect the antibacterial activity of manuka honey, the total antimicrobial action of the honey under these conditions is still significantly higher than that of sugar syrup. Environmental stress such as gastrointestinal acidity and enzymes, perhaps as well as the atmospheres as discussed in Chapter 5, may actually not only affect manuka honey but also cause alteration in bacterial morphology. To thoroughly understand the characteristics and the mechanism of non-peroxide activity in manuka honey it is therefore necessary to further investigate the relationship between the honey, the microorganisms and their stress responses.

## GENERAL DISCUSSION

---

This chapter summarises and discusses the results, findings and weaknesses of the work in this thesis, and also provides several suggestions for further studies that could be approached in future.

This research project arose out of a simple question: would the substantial antibacterial activity of manuka honey be effective against enteropathogens, and would it be as effective (or useful) in gastrointestinal environment as suggested in *in vitro* sensitivity testing? This project then came to an issue that, rather than it being the effect of gastrointestinal environment on the antibacterial activity of the honey, perhaps it was also (and perhaps more) about the effect of the gastrointestinal environmental stress (anaerobiosis, Chapter 5; exposure time, Chapter 6; acidity and gastrointestinal enzymes, Chapter 7) on bacterial sensitivity of microbes to the honey.

## 8.1 The antibacterial efficacy of standardised manuka honey

In this thesis manuka honey with standardised antibacterial activity has been used to evaluate its potential to treat gastrointestinal bacterial infections. Honey has been utilised historically to treat infections worldwide, but unfortunately many of the reports estimating the antibacterial activity in honey are not comparable because those reports did not standardise the honey of interest using a reference antiseptic. Furthermore, in those reports some details that in fact may influence the result of the sensitivity test are absent.

Manuka honey is now widely known by the public to have exceptional antibacterial activity, but it is widely believed that all manuka honey has the same activity. An extensive survey done by [Allen et al. \(1991a\)](#) has shown clearly that not all manuka honey is the same, and also that some manuka honey samples in fact do not have any detectable antibacterial activity if the enzyme catalase is added to remove hydrogen peroxide. [Allen et al. \(1991b\)](#)



found that the antibacterial activity of 50 manuka honey samples tested for both total activity and non-peroxide activity varied greatly in potency, from not detectable to equivalent to that of over 30% phenol solution. Indeed, at the beginning of this PhD project, a manuka honey with a very high level of activity (M113) was used because it was not realised that the activity was much higher than that stated on the label. After it was realised, a honey with a near-median level of activity was used (M115).

Some species of bacteria are inhibited by quite low levels of osmolarity, so inhibition by honey that is observed may be due to the sugar content rather than to hydrogen peroxide or non-peroxide factors. This is why it is important to include an artificial honey as a reference, so that the antibacterial efficacy of factors other than the osmolarity can be distinguished.

Another variable that is commonly missed out in studies that are in the literature is the cell density of the bacteria being tested in the susceptibility assay. It is generally observed that the higher the cell number, the more resistant the cells are to antimicrobial agents. Depending on the species of bacteria or the antibacterial agents being tested, the MIC could rise 4 to 16-fold with as little as 0.5 log<sub>10</sub> increase in inoculum density (Aldridge and Schiro, 1994). Wiegand and Burak (2004) reported that the MIC of eight tested antibiotics against *P. shigelloides* dramatically increased from  $\leq 0.03$  mg/l with 10<sup>5</sup> CFU/ml up to 16 mg/l with 10<sup>6</sup> CFU/ml. It has also been observed that the influence of inoculum size substantially increased if the inoculum exceeded 9×10<sup>7</sup> CFU/ml (Edwards et al., 1991), if the antibacterial agents were tested under anaerobic conditions (Aldridge and Schiro, 1994; Edwards et al., 1991), or if the antibacterial agents were not rapidly bactericidal (Eng et al., 1985). The influence of inoculum density on sensitivity studies is understandable because an increase in the inoculum would reduce the effective concentration or the per-cell concentration of antibacterial agents (Udekwu et al., 2009). Therefore, without the informa-

tion on the cell density being given, it would be difficult to determine if the reported sensitivity of the microbes to the antibacterial agents being tested is actually over-estimated or under-estimated. In this thesis both the antibacterial potency and the cell density are standardised, and this makes the findings from this thesis of greater value than those from other similar work where this was not done.

Although the materials used in the work in this thesis have been controlled, it must not be forgotten that one should not expect the results obtained in this *in vitro* project to be reflecting the actual efficacy of manuka honey when it is used to treat bacterial gastroenteritis *in vivo*, because the gastrointestinal tract is an extremely complex micro-ecosystem, and it is impossible in a laboratory to mimic all factors that are involved in the tract.

In this PhD project, the sensitivity of a number of gastrointestinal microbes to manuka honey was first determined in the “simplest” condition (*i. e.* an *in vitro* environment that is commonly used in an antimicrobial agent sensitivity test; Chapter 4), followed by considering the anaerobic conditions that could result in there being no hydrogen peroxide produced in manuka honey (Chapter 5). The possible recovery in the growth of bacterial cells simulating if honey is removed from the bacteria by absorption from the intestine or by flow past immobilised bacteria in the gut was studied (Chapter 6), then lastly the possible influence of the gastrointestinal pH as well as enzymes on the potency of manuka honey was studied (Chapter 7). Note that in these chapters, each factor was considered separately. For instance, in Chapter 7 where the effects of acidity and enzymes on the MIC and MBC values was studied, the possible influence caused by the anaerobic conditions is not taken into count. Similarly, in the pharmacodynamic assays (Chapter 6) neither the presence / absence of oxygen nor the gastrointestinal acidity/enzymes were considered. *In vivo*, these factors certainly would be

involved simultaneously, but that would make the investigation much more complex.

Despite the fact that the work in this thesis is over-simplified from the viewpoint of the real gastrointestinal environment, the results of this thesis do demonstrate that the antibacterial properties of manuka honey may aid in the treatment of bacterial infection in the gut. Additionally, the unexpected tolerance of probiotics to the antibacterial activity of manuka honey may also help improve the gastroenteritis symptoms (as reviewed in Chapter 1), as honey could be used therapeutically without disturbing their growth. This may be helped by the prebiotic action of honey on probiotics as described in Chapters 1, 4 and 6. However, the major concern to evaluate whether or not honey is likely to help clear infection in the gastrointestinal environment would be whether a sufficient concentration of honey could be achieved in the tract, because the concentration of manuka honey would be diluted in the gut by secretions and by water in food or drink. ORS (oral rehydration solution) has been widely used to treat gastroenteritis, and perhaps one may replace the carbohydrate component in ORS with manuka honey so that the rehydration solution may provide an antibacterial function in addition to merely rehydrating the patient. To achieve this, the amount of the honey in the rehydration solution would need to be re-evaluated because the concentration of the carbohydrate in ORS is 75 mmol/l ([World Health Organisation, 2006](#)), or 0.87% v/v glucose. Considering that honey contains approximately 40% glucose, the concentration of glucose in ORS would be equivalent to that of 2.175% honey solution. This concentration of honey is clearly too low to have a practical antibacterial effect on bacteria in the gut, and therefore the recipe of the honey rehydration solution needs to be modified rather than just replacing the glucose in ORS with the equivalent strength of manuka honey. In the clinical trial done by [Haffejee and Moosa \(1985\)](#), an oral rehydration solution that contained 5% (v/v) of pure honey

(floral source not given) was used and achieved successful results and faster clearance of bacterial infection. Another possible solution that may be of some help to ensure the achievable antibacterial concentration of manuka honey in the gut, and also the time the concentration of honey remains above the MIC/MBC, would be to ingest the honey when the tract is empty so that the active component in the honey would not be largely diluted *in vivo*. It is also possible that there would be an increase in concentration of antibacterial activity when water is absorbed in the gut. However it is not known whether or not the antibacterial factors in manuka honey would also be absorbed in the gut, and further research is required to elucidate this.

The effect of acidic conditions and that of pepsin on the antibacterial activity of manuka honey was unfortunately not determined successfully because the acidity inhibited the bacteria. In theory, the antibacterial activity of the honey due to hydrogen peroxide would be destroyed in harsh acid conditions, as described in Chapter 7. On the other hand, it is not known if the non-peroxide antibacterial component in manuka honey (now identified as a high concentration of methylglyoxal; see later) is likely to be destroyed in the gastric environment. Methylglyoxal has been reported to react with arginine and lysine residues (Nemet et al., 2006) and is more reactive (*i. e.* less stable) in alkaline than in acidic conditions (Nemet et al., 2006). However, methylglyoxal accounts for only half of the non-peroxide activity because an unidentified synergist is now known to be involved in the action of non-peroxide antibacterial activity of the honey (Molan, 2008a). Therefore the stability of this activity in the presence of pepsin and acid still needs to be experimentally proved. If the gastric factor is of much concern, perhaps this issue can again be minimised by ingesting manuka honey when the stomach is empty because in the absence of chyme containing large quantities of undigested proteins there would be less stimulation of secretion of gastrin, and therefore acids and enzymes (Martini, 2001).

Although measurements of MIC and MBC are commonly used to evaluate the efficacy of antibacterial agents, these parameters would not be meaningful in the case of evaluating the treatment of enteropathogens using honey. It is presumable that the fluidity of honey and the possibility of the absorption of the antibacterial components in the honey would result in a very short contact time of honey with bacteria in the gastrointestinal tract. The time-to-kill and the postantibiotic assays have shown that the MIC/MBC parameters are not sufficient to evaluate the efficacy of honey *in vivo* because the conditions for the MIC/MBC test do not resemble that in the tract in terms of the contact time. Also, although the results from the postantibiotic effect assay conducted in this thesis have shown that the antibacterial effect of manuka honey persists for a few hours after one hour of partial inhibition, it is not known whether or not this effect would still exist at lower honey concentration than that has been used in this thesis (20%) and/or with shorter contact time of the honey with bacteria.

Note also that honey has also been reported to detach bacterial cells from the host cells (Alnaqdy et al., 2005; Breton and Pineau, 1999). Attachment to the gastrointestinal mucosa usually is the first step of infection by enteropathogens, and therefore even if the antibacterial activity of honey is not strong enough to inhibit bacteria, it may still be useful to treat the pathogens if the honey is effective in detaching bacteria. Like the postantibiotic effect assays, it would be of interest to test the effect of different concentrations of the honey as well as that of different contact times on the detaching effect in the future. Future work should also examine a range of honeys to find the best type for detaching bacteria. Breton and Pineau (1999) investigated *Robinia pseudoacacia* honey, lime-tree (*Tilia* spp.) honey, lavender honey, chestnut honey, honeydew from conifers, citrus honey, alpine flowers honey and "Gatinais" honey. Of these, *R. pseudoacacia* honey was found the best. This suggests that the ability to detach varies between honeys.

Furthermore, honey has been shown to have anti-inflammatory and antioxidant activities (reviewed in Chapter 1). Since inflammation and reactive oxygen species (ROS) play a role in gastroenteritis, the possible usefulness of the anti-inflammatory and anti-oxidative activities of manuka honey at different conditions may also warrant further studies.

## **8.2 Environmental stress and the efficacy of antibacterial agents**

Although in this thesis it was initially aimed to evaluate the usefulness of manuka honey for treating bacterial gastroenteritis, by comparing the MIC/MBC values obtained with conventional susceptibility testing with those obtained when including some gastrointestinal factors (anaerobiosis, exposure time, gastrointestinal acidity and enzymes), most of the environmental factors studied may actually have also affected the bacterial cells rather than have affected just the antibacterial activity of manuka honey itself. For example, in Chapter 5 the effect of oxygen limitation on the activity of the honey was investigated, because oxygen is required for the production of hydrogen peroxide, but the results could also have been due to oxygen limitation also affecting the sensitivity of bacteria to the non-peroxide activity in manuka honey. In Chapter 7 the studies evaluating the effect of acidity and enzymes (and bile salts) on the activity of manuka honey could also have been showing the direct effect of these conditions on the bacterial cells rather than on the honey.

Bacterial cells have developed numerous mechanisms to be able to survive a wide range of environments, and therefore it is important to take the alteration in the environment to be used or the bacterial metabolism pathway in to account when evaluating the efficacy of an antibacterial agent.

*E. coli*, for example, regulates the production of the enzymes catalase and superoxide dismutase by Fnr, ArcAB, OxyR and SoxRS regulatory systems in response to dioxygen concentration so as to protect itself from reactive oxygen species when it is in the air. Also, this species increases anaerobic fermentative reactions to provide itself with energy in anaerobic conditions such as in the intestinal tract (Sawers, 1999; Iuchi and Weiner, 1996). As any environmental stress could trigger gene regulation responses that may consequently alter the cell metabolism or the cell morphology, the alteration in the culture environment may also directly or indirectly alter the effectiveness of antimicrobial agents on the bacterial cells. Indeed, whilst some wide-spectrum antibiotics such as chloramphenicol can be effective against a large number of Gram positive, Gram negative aerobic, and anaerobic, bacteria (Corey et al., 2007), some antibiotics such as metronidazole are useful only in anaerobic conditions (Corey et al., 2007) due to the drug being specific to the bacterial metabolism which occurs in anaerobiosis. In fact, many studies have shown that even wide-spectrum antibiotics can have different efficacy against a single species in different conditions. Suller and Lloyd (2002) reported that whilst vancomycin gave similar MIC value and duration of the postantibiotic effect in *S. aureus* under aerobic and anaerobic conditions, the death rate was found to be greater in the presence of oxygen than in anaerobic conditions. Nanavaty et al. (1998) reported that the MIC of the aminoglycosides for *E. coli* remained unchanged under various of atmospheres (aerobic and anaerobic) and ion concentrations as long as the pH was above 7, whereas the MIC increased up to 5-fold as the pH decreased from 8.5 to 5.5. *P. aeruginosa* seems to be more resistant to environmental stresses in anaerobic conditions than in aerobic conditions (Field et al., 2005; Hill et al., 2005). One environment stress may also induce cross-protection in bacterial cells against other unrelated stresses. It has been reported that after adaptation to acidic conditions, *L. monocytogenes* demonstrated increased

virulence and tolerance to thermal, osmotic or chemical (*e. g.* crystal violet and ethanol) stresses (O'Driscoll *et al.*, 1996). Alkaline stress on *E. faecalis* has been reported to induce alteration in protein synthesis and cross-protection to bile salts (Flahaut *et al.*, 1997). Bile acids have been found to induce biofilm formation in *V. cholerae* due to *vps* (*Vibrio polysaccharide synthesis*) genes (Hung *et al.*, 2006), which contributes to the possibility of increase in tolerance to undesirable environments. These reports indicate the complexity that needs to be taken into account when evaluating the efficacy of an antibacterial agent *in vivo* solely from the conventional sensitivity tests *in vitro* in which the MIC/MBC values are mostly obtained in simplest conditions.

The findings from this thesis, unfortunately, do not demonstrate whether or not the gastrointestinal environmental stress responses are likely to be of any relevance to the efficacy of manuka honey *in vivo*. It was impossible to evaluate the efficacy of manuka honey with regards to the alteration in bacterial metabolism because the mechanism of the antibacterial activity in manuka honey is not known. For instance, it is not clear in this stage whether the increase in the MIC values of manuka honey in the presence of pancreatin or bile is due to the antibacterial activity being decreased by these substances, or due to cross-protection being induced in the bacterial cells. Nonetheless, given that most MIC values and MBC values of manuka honey in all conditions tested in this thesis are lower than those of artificial honey, it is obvious that the antibacterial efficacy of manuka honey still remains to some degree under most of the gastrointestinal environmental conditions. Also, since the antibacterial action in honey is multi-factorial, it would be more difficult for bacteria to respond and form protection against honey than against antibiotics.



### 8.3 Methylglyoxal in manuka honey

The component(s) responsible for the non-peroxide antibacterial activity in manuka honey have remained unidentified for decades since the discovery of this unusual activity. This has been because honey is complex in its composition. It was not until much of the work in this thesis had been completed that methylglyoxal (MGO; shown in Fig. 8.1) was identified as the substance responsible for the non-peroxide antibacterial activity in manuka honey (Adams et al., 2008; Mavric et al., 2008). However, an as-yet unidentified synergist is also present which doubles the antibacterial potency of MGO (Molan, 2008b,a).

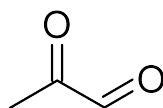

Figure 8.1: The chemical structure of methylglyoxal (MGO).

Methylglyoxal, also called 2-oxo-propanal, is formed in organisms as a side-product of several metabolic pathways, in which glycolysis is the most important source (Inoue and Kimura, 1995). Methylglyoxal is highly cytotoxic (Kalapos, 1999), although generally cells may detoxify it through several mechanisms such as the glyoxalase systems, as shown in Fig. 8.2 (Thornalley, 2003; Vander Jagt, 1993).

The effects of methylglyoxal on living organisms is controversial and remains to be clarified. While there have been a number of reports regarding the toxicity of methylglyoxal to living organisms, some other research has shown that methylglyoxal may not be toxic when used with ascorbic acid and creatine, and that it may be safely used as an anticancer drug (Ghosh et al., 2006). The high concentration of methylglyoxal in manuka honey should not be of concern from a practical point of view. According to Adams et al. (2008) and Mavric et al. (2008), the amount of methylglyoxal in manuka



honey varies from 38 to 828 mg/kg. Most reports concerning the cytotoxicity demonstrated the results by treating plants, mammals, yeasts (*Saccharomyces cerevisiae*) and prokaryotes, either *in vivo* or *in vitro*, with approximately 10 mmol/l (720 mg/l) or higher concentration of methylglyoxal long-term (Kalapos, 1999). If we apply this to human ingestion of manuka honey and also consider that the human body contains about 50 litres of water, this would mean one needs to take a dose of approximately 50 kg of manuka honey with a high level of methylglyoxal to reach that cytotoxic amount of methylglyoxal from the honey. Even then, there is a possibility that not all of the methylglyoxal will be absorbed from the gut, and that some of what does get absorbed will be broken down by metabolism. A number of trials have been conducted in mammals, but the exceptionally high doses the animals were subjected to in those trials may render questionable the interpretations. For instance, Kalapos et al. (1991) reported that 800 mg/kg body weight of methylglyoxal was lethal in mice within 4 hours after intraperitoneal injection. It is questionable if this is of meaning when applied to humans consuming honey, as it equates to consuming about 50 kg of honey in a single dose, even if all of the methylglyoxal is absorbed from the gut. Similarly, Furihata et al. (1985) administered methylglyoxal ranging 300–600 mg/kg body weight by gastric tube to demonstrate an unscheduled DNA synthesis in male F344 rats. Interestingly, despite the high level of methylglyoxal being reported by Adams et al. (2008) and Mavric et al. (2008), toxicity or related disease caused by ingesting manuka honey has never been reported. Also to be noted is that in published reports on animal trials, the animals were observed over days and but it is not clear how rapidly nor how much the methylglyoxal in food would be absorbed in the gut. The interacting effect of other ingredient (*e. g.* antioxidants) in food/honey on the absorption of methylglyoxal and the action of the synergist in manuka honey also remains to be elucidated.

## 8.4 Conclusion

Manuka honey has been shown in published literature and in the work in this thesis to be effective against a wide range of gastrointestinal pathogens, although it is too early to conclude from the demonstrated data in this thesis that the antibacterial activity of manuka honey would still be effective in the intestine. In the work in this thesis it has been found that manuka honey with a near median level of antibacterial activity tested against most of the common enteropathogens inhibits at < 10%, kills at < 16.6%, and stunts the growth for 2–3 hours at 20% if used *in vitro*. It was also found that the honey loses no more than 50% of its antibacterial efficacy when tested *in vitro* under most conditions simulating those in the intestine (anaerobiosis and in the presence of intestinal components). Because acidity itself inhibits bacteria, it is not known whether or not the honey would work in the stomach. However, published findings have shown that the activity of honey is not harmed by exposure to low pH then neutralisation, therefore it should still be effective once it passes through the stomach to the intestines.

Gastroenteritis has generally been treated with oral rehydration therapy (ORT) that consists of carbohydrates and electrolytes. In addition to its antibacterial action, manuka honey could also be used to provide carbohydrates in an electrolyte solution to rehydrate patients with gastroenteritis. Furthermore, because honey also provides additional bioactivities that the conventional ORS does not have (such as antioxidant, anti-inflammatory and prebiotic activity), it is likely that a rehydration solution containing manuka honey and electrolytes would be superior to ORS. With an appropriate recipe of honey rehydration solution and further investigation to find the most appropriate dosage and frequency of doses, a clinical trial may be warranted.

## 8.5 Future work

There is always no end for a research study, and during this project a number of new questions and interesting topics arose. This section gives some suggestions on future work that could be done if further research studies are to be carried out.

### 8.5.1 *Enteropathogens other than common gastrointestinal pathogens*

The gastrointestinal environment is a rather complex reservoir of microorganisms, and it is believed that there are still many species of bacteria that have not been identified or cannot even be cultured but have shown potential to cause diseases. Despite the fact that *Campylobacter* is one of the most predominant causes of gastroenteritis, and also that the majority of *Campylobacter* spp. appear to be *C. jejuni* and *C. coli* (as identified in Section 2.4), many other “*Campylobacter* spp., *Helicobacter* and related organisms” (CHRO) have been strongly indicated to be involved in human diarrhoea (Stephen On, ESR, Christchurch; personal communication). Also, an increasing number of bacteria, including *Campylobacter* spp. and *E. coli*, are now known to enter a viable but nonculturable (VBNC) state (Oliver, 2005).

The determination of the sensitivity of the CHRO or VBNC can be quite challenging because, as described above, these organisms cannot be cultured with microbiological techniques available today. In other words, susceptibility assays based on bacterial culture would not be feasible unless new culturing techniques for these unusual microbes are established. Since many of these organisms are thought to be clinically important, it would be

worth considering an investigation into the efficacy of manuka honey against these microorganisms once ways of testing them have been developed.

### **8.5.2 *The efficacy of honey on viral gastrointestinal disease***

Although the focus of this project has been bacterial gastrointestinal disorder, it should be noted that a large proportion of gastroenteritis is caused by viruses. Norovirus and rotavirus are the most common causes of viral gastroenteritis and have caused several notable outbreaks over the world. There has not been an effective treatment against these viruses other than to apply oral rehydration therapy.

Although honey has been reported to be effective against bacteria, relatively little is known about its antiviral activity. Haffejee and Moosa's clinical report showed that honey halved the duration of the symptom of bacterial but not viral diarrhoea (Haffejee and Moosa, 1985). Al-Waili (2004) reported that honey revealed a better healing result on labial herpes, genital herpes and lesions than acyclovir did. It would be of much interest to see whether or not honey would be of some help to treat viral gastroenteritis.

### **8.5.3 *The efficacy of honey on protected enteropathogens***

Most food-borne pathogens get into the gastrointestinal system through the diet. *Campylobacter* and *Salmonella* spp., for example, usually exist in chicken and pork. If the contaminated meat is not well cooked, the organisms are ingested along with the meat. *Bacillus* spp. may also exist in rice. When these organisms get into the body through food, the cells are protected by the food substrate such as protein or lipid, which may provide the organisms a protection from the digestive fluid or enzymes in the body. There has

been a report showing that bacteria inoculated on a food matrix revealed higher resistance to acid than the 'naked' control (Waterman and Small, 1998). In another research study using a simulated gastric fluid to examine the survival of *E. coli* O157:H7 and some *Shigella*, it was reported that the inactivation rate significantly declined if cooked ground beef was included (Tamplin, 2005), suggesting that food ingredients can provide bacteria with a protective matrix against environmental stress.

Forming a biofilm is another way a bacterial species protects itself from a hostile environment. Many bacteria including *Campylobacter* spp. and *H. pylori* have been reported to form biofilms in the gastrointestinal tract, and this is thought to be one of the reasons why *H. pylori* eradication therapy sometimes fails (Buswell et al., 1998; Carron et al., 2006; Cole et al., 2004). Although honey has recently been reported to be able to inhibit *P. aeruginosa* in biofilms (Cooper and Jenkins, 2008), more research studies are required because the work done by Cooper and Jenkins (2008) used topical treatment of the *P. aeruginosa* biofilm with honey whereas this inhibition may not occur in the gastrointestinal tract where an enteric biofilm is unlikely to be persistently exposed to honey. The effect of the state of bacteria *e. g.* biofilm versus planktonic on the efficacy of honey will also have to be investigated in future.

#### 8.5.4 Pharmacodynamics

In Chapter 6 where the postantibiotic effect assay was described, bacteria were exposed to 20% of manuka honey for 1 h. In the gut, the time bacterial cells are exposed to honey may be shorter. Therefore in future work it would be worth studying various conditions of pharmacodynamics, such as finding if the postantibiotic effect is induced with a very short exposure time (0.5 h or even shorter) to manuka honey.

In the preliminary work, 5%, 10%, 15% and 20% solutions of manuka honey were tested with *S. aureus* ATCC 15923, and the postantibiotic effect was found to be 1.15 h, 2.42 h, 2.46 h and 2.53 h, respectively. It is of interest that whereas the postantibiotic effect of 5% honey was shorter than that of 20%, that of 10% and 15% were almost equivalent to that of 20%, suggesting that the postantibiotic effect of manuka honey on *S. aureus* may not be concentration-dependant once the concentration of the honey is above the MIC. It would be of interest to see if this is applicable to other organisms.

The determination of the pharmacodynamic parameters can go one step further, so that the sub-MIC effect (SME) and the postantibiotic-sub MIC effect (PA-SME) can also be determined. The sub-MIC effect is defined by the formula  $SME = T_s - C$ , where  $T_s$  is the time it takes for the culture exposed only to sub-MICs to increase  $1 \log_{10}$  unit above the counts observed immediately after washing and  $C$  is the corresponding time for the unexposed culture (Odenholt-Tornqvist et al., 1991; Odenholt, 2001). The PA-SME, on the other hand, is defined by the formula  $PA - SME = T_{pa} - C$ , where  $T_{pa}$  is the time for the previously antibiotic-exposed cultures, which thereafter had been exposed to different sub-MICs, to increase by  $1 \log_{10}$  unit above the counts observed immediately after washing and  $C$  is the corresponding time for the unexposed culture (Odenholt-Tornqvist et al., 1991; Odenholt, 2001).

In Chapter 6 it was noted that an improved yet standardised method for pharmacodynamics assays needs to be developed, because otherwise it is not feasible to examine the pharmacodynamics property for a large number of samples.

#### 8.5.4.1 The mechanisms of PAE induced by honey in microorganisms

Stubbings et al. (2006) carried out an interesting research using *E. coli* to observe the recovery in macromolecular synthesis during the postantibiotic



effect stage induced by rifampicin and gentamicin, and found that the length of the postantibiotic effect coincided with the recovery of synthesis of either RNA, protein or both, depending on which antibiotics were used. Examining the recovery of the synthesis of macromolecules (DNA, RNA and protein) in different microorganisms during the honey-induced postantibiotic effect stage may be of some help in understanding the mechanism of the action of the non-peroxide antibacterial activity in manuka honey.

### 8.5.5 *The effect of honey on probiotics*

Probiotics, or beneficial bacteria, are considered to be competing against other organisms, which may be pathogenic, by means of colonization and secreting antibacterial component such as lactate, lantibiotics, etc. From the susceptibility tests done in this thesis project, it was realized that the MIC/MBC of manuka honey for probiotics are higher than those for pathogens.

Several probiotics are known to produce antimicrobial substances to help compete with other organism. Nisin is one of the well known examples and its synthesis and mechanisms of action have been investigated in many research studies (Chatterjee et al., 2005; Cheigh and Pyun, 2005; Bernbom et al., 2006; Joerger, 2003). However the relationship between the production of nisin and the effect of honey on stimulating the growth of probiotics is unknown. As nisin or *Lactobacillus*-produced antibiotics (lantibiotics) are produced primarily for competing with other organisms, the amount of production may not be relevant to the number of the cells or the growth rate. Honey has been reported to reveal a potential prebiotic activity (Chick et al., 2001; Ezz El-Arab et al., 2006; Rosendale et al., 2008; Sanz et al., 2005; Shamala et al., 2000; Shin and Ustunol, 2005) and this is thought to be due to oligosaccharides in the honey. Understanding the relationship between honey, probiotics and lantibiotics would be useful

for either treating or preventing gastrointestinal disorders without using antibiotics. One significant example is protection of the gut from antibiotic-associated diarrhoea (AAD) such as *C. difficile*-associated diarrhoea (CDAD) that has been described previously in Sections 1.3.5 and 1.4.2. If the beneficial bacteria are stimulated or strengthened, it would increase the protection of the body from infection. Even if one is infected by an enteropathogen, the dosage of antibiotics could be reduced or even omitted if proper use of the microflora is made.

In Chapter 6 it was found that probiotics are not only relatively resistant to the antibacterial activity of the manuka honey than are enteropathogens, but also their growth is stimulated by the honey compared with the control group in a plain medium. This suggests the possibility that honey may stimulate the ability of probiotics to compete with pathogens. If this hypothesis is true then humans may strengthen their resistance to bacterial gastrointestinal diseases by taking honeys, even though the reachable concentration may be lower than the MIC for the causative enteropathogens. To investigate this, several experiments will need to be done. The first is to co-culture probiotics with enteropathogens in broth medium and observe their growth so that, based on the growth profile, we may compare the effect of honey on both probiotics and enteropathogens. The second is to investigate the effect of honey on the attachment of organisms on intestinal cells. As attachment on intestinal epithelial cells is the first step of bacterial infection, the prevention of attachment of pathogenic organisms would reduce the possibility of the disease. Some research has revealed the usefulness of honey regarding this (Alnaqdy et al., 2005; George et al., 1978a). Alnaqdy et al. (2005) co-incubated *Salmonella* spp. with intestinal epithelial cells, and the authors observed that the *Salmonella* spp. treated with 12.5% honey had lower adherence than those not treated with honey. George et al. (1978a) did not state the floral source of the honey nor the

species of the rat's oral flora they had used, but they observed that honey reduced the thickness of epithelial attachment. It is not known whether these results are because the honey treatment caused the loss of the viability and thus the activity of the bacterial cells or because the honey affected components of the bacterial cell walls or the epithelial cell membranes so that the organisms are less likely to adhere to the receptors on the epithelial cells. It would be of interest to see if this phenomenon can be observed with other gastrointestinal microorganisms, as the same effect of honey may also reduce the adherence of probiotics to epithelial cells. The last trial would be to treat both epithelial cells and bacteria with honey, wash it off, and then investigate if honey has any effect on the interaction between epithelial and bacterial cells.

### ***8.5.6 The mechanism of the non-peroxide antibacterial activity in manuka honey***

The lack of a detailed understanding of the nature of the non-peroxide antibacterial component in manuka honey has made it difficult to explore the mechanism of action of the antibacterial property of manuka honey over the decades since its discovery. The recent discovery that methylglyoxal (MGO) is responsible for the non-peroxide antibacterial activity of manuka honey (Adams et al., 2008; Mavric et al., 2008) and the identification of its source being dihydroxyacetone abundantly contained in the nectar from manuka trees (Adams et al., 2009) gives some clues on the long-lasting mysteries on the antibacterial properties of the honey. However, several puzzles that have existed for years now turn into the following paradoxes - how and why does the methylglyoxal in manuka honey inhibit or even kill bacteria, without causing any emergence of resistant species (Blair et al., 2009; Cooper et al., 2009) like most other antibacterial agents do? Since methylglyoxal is largely

responsible for the non-peroxide antibacterial activity of manuka honey, would any bacteria that are resistant to methylglyoxal also be resistant to, or at least tolerate, the antibacterial activity of manuka honey? Why does the synergy in the potency of antibacterial activity occur only when methylglyoxal is added to manuka honey but not to other types of honey?

Now that the non-peroxide antibacterial substance has been unveiled, investigating how methylglyoxal works in manuka honey should be the next research topic to be focused on, so that this therapeutic property of honey can be yet further understood and utilised. More research needs to be done on the mechanism by which pure methylglyoxal kills bacteria, since little has been published on this. Then the mechanism of action of methylglyoxal in manuka honey needs to be studied in comparison to gain an understanding of how the synergist in manuka honey works.

## BIBLIOGRAPHY

---

- Adams, C. J., Boulton, C. H., Deadman, B. J., Farr, J. M., Grainger, M. N. C., Manley-Harris, M., and Snow, M. J. (2008).** "Isolation by HPLC and characterisation of the bioactive fraction of New Zealand manuka (*Leptospermum scoparium*) honey." *Carbohydrate Research*, 343(4): 651–659.
- Adams, C. J., Manley-Harris, M., and Molan, P. C. (2009).** "The origin of methylglyoxal in New Zealand manuka (*Leptospermum scoparium*) honey." *Carbohydrate Research*, 344(8): 1050–1053.
- Adcock, D. (1962).** "The effect of catalase on the inhibine and peroxide values of various honeys." *Journal of Apicultural Research*, 1: 38–40.
- Adebolu, T. T. (2005).** "Effect of natural honey on local isolates of diarrhea-causing bacteria in southwestern Nigeria." *African Journal of Biotechnology*, 4(10): 1172–4.
- Åkerlund, T., Persson, I., Unemo, M., Norén, T., Svenungsson, B., Wullt, M., and Burman, L. G. (2008).** "Increased sporulation rate of epidemic *Clostridium difficile* type O27/NAP1." *Journal of Clinical Microbiology*, 46(4): 1530–1533.
- Al-Bukhari, M. (1976).** *Sahih Al-Bukhari*, volume VII. Kazi Publications, Chicago, 3rd, revised edition.
- Al-Nassir, W. N., Sethi, A. K., Li, Y., Pultz, M. J., Riggs, M. M., and Donskey, C. J. (2008).** "Both oral metronidazole and oral vancomycin promote persistent overgrowth of vancomycin-resistant enterococci during treatment of *Clostridium difficile*-associated disease." *Antimicrobial Agents and Chemotherapy*, 52(7): 2403–2406.

- Al Somal, N., Coley, K., Molan, P., and Hancock, B. (1994).** "Susceptibility of *Helicobacter pylori* to the antibacterial activity of manuka honey." *Journal of the Royal Society of Medicine*, 87: 9–12.
- Al-Waili, N. (2004).** "Topical honey application vs. acyclovir for the treatment of recurrent herpes simplex lesions." *Medical Science Monitor*, 10(8): MT94–8.
- Al-Waili, N. S. (2003).** "Topical application of natural honey, beeswax and olive oil mixture for atopic dermatitis or psoriasis: partially controlled, single-blinded study." *Complementary Therapies in Medicine*, 11(4): 226–34.
- Al-Waili, N. S., Akmal, M., Al-Waili, F. S., Saloom, K. Y., and Ali, A. (2005).** "The antimicrobial potential of honey from United Arab Emirates on some microbial isolates." *Medical Science Monitor*, 11(12): BR433–8.
- Aldridge, K. E. and Schiro, D. D. (1994).** "Anaerobic susceptibility testing. Slight differences in inoculum size can make a difference in minimum inhibitory concentrations." *Diagnostic Microbiology and Infectious Disease*, 18(3): 191–195.
- Ali, A., Chowdhury, M., and Al Humayyd, M. (1991).** "Inhibitory effect of natural honey on *Helicobacter pylori*." *Tropical Gastroenterology*, 12(3): 139–43.
- Ali, A. T. M. (1995).** "Natural honey accelerates healing of indomethacin-induced antral ulcers in rats." *Saudi Medical Journal*, 16(2): 161–166.
- Ali, A. T. M., Al-Humayyd, M. S., and Madan, B. R. (1990).** "Natural honey prevents indomethacin- and ethanol-induced gastric lesions in rats." *Saudi Medical Journal*, 11(4): 275–279.
- Allen, K. L., Molan, P. C., and Reid, G. M. (1991a).** "A survey of the antibacterial activity of some New Zealand honeys." *The Journal of Pharmacy and Pharmacology*, 43(12): 817–822.

- Allen, K. L., Molan, P. C., and Reid, G. M. (1991b).** "The variability of the antibacterial activity of honey." *Apiacta*, XXVI: 114–21.
- Allos, B. M. (2001).** "Campylobacter jejuni Infections: update on emerging issues and trends." *Clinical Infectious Diseases*, 32(8): 1201–1206.
- Alnaqdy, A., Al-Jabri, A., Al Mohrooqi, Z., Nzeako, B., and Nsanze, H. (2005).** "Inhibition effect of honey on the adherence of Salmonella to intestinal epithelial cells *in vitro*." *International Journal of Food Microbiology*, 103(3): 347–51.
- Ang, C., Jacobs, B. C., and Laman, J. D. (2004).** "The Guillain-Barré syndrome: a true case of molecular mimicry." *Trends in Immunology*, 25(2): 61–6.
- Anonymous (2005).** "Outbreak of *Clostridium difficile* in a hospital in south east England." *CDR Weekly*, 15(24).
- Archimandritis, A., Souyioultzis, S., Katsorida, M., and Tzivras, M. (1998).** "*Clostridium difficile* colitis associated with a 'triple' regimen, containing clarithromycin and metronidazole, to eradicate *Helicobacter pylori*." *Journal of Internal Medicine*, 243(3): 251–253.
- Asakura, H., Suzuki, K., and Honma, T. (2007).** "Recent advances in basic and clinical aspects of inflammatory bowel disease: Which steps in the mucosal inflammation should we block for the treatment of inflammatory bowel disease?" *World Journal of Gastroenterology*, 13(15): 2145–2149.
- Astwood, K., Lee, B., and Manley-Harris, M. (1998).** "Oligosaccharides in New Zealand honeydew honey." *Journal of Agricultural and Food Chemistry*, 46: 4958–4962.
- Atrott, J. and Henle, T. (2009).** "Methylglyoxal in manuka honey - correlation with antibacterial properties." *Czech Journal of Food Science*, 27: S163–S165.

- Awad, R. W., Ward, K. L., and Hawker, P. C. (1994).** "Fulminant pseudomembranous colitis (PMC) following triple therapy for *Helicobacter pylori*." *Journal of the Royal College of Surgeons of Edinburgh*, 39(5): 319.
- Axon, A. T. R. (1991).** "*Helicobacter pylori* therapy: effect on peptic ulcer disease." *Journal of Gastroenterology and Hepatology*, 6: 131–137.
- Aysan, E., Ayar, E., Aren, A., and Cifter, C. (2002).** "The role of intra-peritoneal honey administration in preventing post-operative peritoneal adhesions." *European Journal of Obstetrics & Gynecology and Reproductive Biology*, 104(2): 152–155.
- Badawy, O. F. H., Shafii, S. S. A., Tharwat, E. E., and Kamal, A. M. (2004).** "Antibacterial activity of bee honey and its therapeutic usefulness against *Escherichia coli* O157:H7 and *Salmonella typhimurium* infection." *Revue Scientifique et Technique (International Office of Epizootics)*, 23(3): 1011–1022.
- Baldry, M. G. (1983).** "The bactericidal, fungicidal and sporidical properties of hydrogen peroxide and peracetic acid." *Journal of Applied Bacteriology*, 54(3): 417–423.
- Balows, A., Hausler, W. J. J., Herrmann, K. L., Isenberg, H. D., and Shadomy, H. J. (1991).** *Manual of Clinical Microbiology*. American Society for Microbiology.
- Bang, L. M., Bunting, C., and Molan, P. (2003).** "The effect of dilution on the rate of hydrogen peroxide production in honey and its implications for wound healing." *Journal of Alternative and Complementary Medicine*, 9(2): 267–73.
- Barmada, S., Kohlhepp, S., Leggett, J., Dworkin, R., and Gilbert, D. (1993).** "Correlation of tobramycin-induced inhibition of protein synthesis with postantibiotic effect in *Escherichia coli*." *Antimicrobial Agents and Chemotherapy*, 37(12): 2678–83.



- Bartlett, J. G. (2006).** "Narrative review: the new epidemic of *Clostridium difficile*-associated enteric disease." *Annals of Internal Medicine*, 145(10): 758–64.
- Bartlett, J. G., Chang, T., Gurwith, M., Gorbach, S., and Onderdonk, A. (1978).** "Antibiotic-associated pseudomembranous colitis due to toxin-producing clostridia." *The New England Journal of Medicine*, 298(10): 531–534.
- Barton, L. L. (2005).** *Structural and Functional Relationships in Prokaryotes*. Springer.
- Begley, M., Gahan, C. G., and Hill, C. (2005).** "The interaction between bacteria and bile." *FEMS Microbiology Reviews*, 29(4): 625–651.
- Ben Aissa, R. and Al-Gallas, N. (2008).** "Molecular typing of *Salmonella enterica* serovars Enteritidis, Corvallis, Anatum and Typhimurium from food and human stool samples in Tunisia, 2001-2004." *Epidemiology and Infection*, 136(4): 468–475.
- Bennett, T. I. and Parkes, T. (1944).** "Penicillin in sulphonamide-resistant pneumonias." *Lancet*, 246: 305–308.
- Bernbom, N., Licht, T. R., Saadbye, P., Vogensen, F. K., and Nørrung, B. (2006).** "*Lactobacillus plantarum* inhibits growth of *Listeria monocytogenes* in an *in vitro* continuous flow gut model, but promotes invasion of *L. monocytogenes* in the gut of gnotobiotic rats." *International Journal of Food Microbiology*, 108(1): 10–14.
- Bernstein, H., Payne, C. M., Bernstein, C., Schneider, J., Beard, S. E., and Crowley, C. L. (1999).** "Activation of the promoters of genes associated with DNA damage, oxidative stress, ER stress and protein malfolding by the bile salt, deoxycholate." *Toxicology Letters*, 108(1): 37–46.

- Besselink, M. G. H., van Santvoort, H. C., Buskens, E., Boermeester, M. A., van Goor, H., Timmerman, H. M., Nieuwenhuijs, V. B., Bollen, T. L., van Ramshorst, B., Witteman, B. J. M., Rosman, C., Ploeg, R. J., Brink, M. A., Schaapherder, A. F. M., Dejong, C. H. C., Wahab, P. J., van Laarhoven, C. J. H. M., van der Harst, E., van Eijck, C. H. J., Cuesta, M. A., Akkermans, L. M. A., and Gooszen, H. G. (2008).** "Probiotic prophylaxis in predicted severe acute pancreatitis: a randomised, double-blind, placebo-controlled trial." *The Lancet*, 371: 651–659.
- Bilsel, Y., Bugra, D., Yamaner, S., Bulut, T., Cevikbas, U., and Turkoglu, U. (2002).** "Could honey have a place in colitis therapy? Effects of honey, prednisolone, and disulfiram on inflammation, nitric oxide, and free radical formation." *Digestive Surgery*, 19: 306–312.
- Blair, S. (2009).** *Honey in Modern Wound Management*, chapter Chapter 3. Antibacterial Activity of Honey, pages 21–46. Wounds UK.
- Blair, S. E., Cokcetin, N. N., Harry, E. J., and Carter, D. A. (2009).** "The unusual antibacterial activity of medical-grade *Leptospermum* honey: antibacterial spectrum, resistance and transcriptome analysis." *European Journal of Clinical Microbiology & Infectious Diseases*, 28(10): 1199–1208.
- Blakelock, R. T. and Beasley, S. W. (2003).** "Infection and the gut." *Seminars in Pediatric Surgery*, 12(4): 265–74.
- Bogdanov, S., Rieder, K., and Rüegg, M. (1987).** "Neue Qualitätskriterien bei Honiguntersuchungen." *Apidologie*, 18(3): 267–278.
- Bolton, F. and Coates, D. (1983).** "A comparison of microaerobic systems for the culture of *Campylobacter jejuni* and *Campylobacter coli*." *European Journal of Clinical Microbiology*, 2(2): 105–110.
- Bolton, F., Coates, D., and Hutchinson, D. (1984).** "The ability of *Campylobacter* media supplements to neutralize photochemically induced tox-

- icity and hydrogen peroxide." *The Journal of Applied Bacteriology*, 56(1): 151–7.
- Bondi, A. and Dietz, C. C. (1945).** "Penicillin-resistant Staphylococci." *Proceedings of the Society for Experimental Biology and Medicine*, 60: 55–58.
- Bowden, K. and Fabian, W. M. F. (2001).** "Reactions of carbonyl compounds in basic solutions. Part 36: The base-catalysed reactions of 1,2-dicarbonyl compounds." *Journal of Physical Organic Chemistry*, 14(11): 794–796.
- Boyle, R. J., Robins-Browne, R. M., and Tang, M. L. K. (2006).** "Probiotic use in clinical practice: what are the risks?" *The American Journal of Clinical Nutrition*, 83: 1256–1264.
- Bradford, P. A. (2001).** "Extended-spectrum  $\beta$ -lactamases in the 21st century: characterization, epidemiology, and detection of this important resistance threat." *Clinical Microbiology Reviews*, 14(4): 933–51.
- Breton, L. and Pineau, N. (1999).** "Use of honey as an agent for decreasing adhesion of micro-organisms." *FR Patent EP0909557A1*.
- Brody, J. R. and Kern, S. E. (2004).** "Sodium boric acid: a Tris-free, cooler conductive medium for DNA electrophoresis." *Biotechniques*, 36(2): 214–6.
- Brook, I. (1989).** "Aerobic and anaerobic microbiology of biliary tract disease." *Journal of Clinical Microbiology*, 27(10): 2373–2375.
- Brumfitt, W., Salton, M. R. J., and Hamilton-Miller, J. M. T. (2002).** "Nisin, alone and combined with peptidoglycan-modulating antibiotics: activity against methicillin-resistant *Staphylococcus aureus* and vancomycin-resistant enterococci." *Journal of Antimicrobial Chemotherapy*, 50(5): 731–734.
- Bühling, A., Radun, D., Müller, W. A., and Malfertheiner, P. (2001).** "Influence of anti-*Helicobacter* triple-therapy with metronidazole, omeprazole

- and clarithromycin on intestinal microflora." *Alimentary Pharmacology & Therapeutics*, 15(9): 1445–1452.
- Buman, M. d. (1953).** "M2 Woelm en gynécologie et en obstétrique." *Praxis*, 42(14): 282.
- Buswell, C. M., Herlihy, Y. M., Lawrence, L. M., McGuiggan, J. T., Marsh, P. D., Keevil, C. W., and Leach, S. A. (1998).** "Extended survival and persistence of *Campylobacter* spp. in water and aquatic biofilms and their detection by immunofluorescent-antibody and -rRNA staining." *Applied and Environmental Microbiology*, 64: 733–741.
- Canani, R. B., Cirillo, P., Romano, C., Malamisura, B., Terrin, G., Pasariello, A., Monguso, F., Morelli, L., Guarino, A., and Working Group on Intestinal Infections of the Italian Society of Pediatric Gastroenterology, Hepatology and Nutrition (SIGENP) (2006).** "Therapy with gastric acidity inhibit increases the risk of acute gastroenteritis and community-acquired pneumonia in children." *Pediatrics*, 117(5): e817–e820.
- Carpenter, H. A. (1998).** "Bacterial and parasitic cholangitis." *Mayo Clinic Proceedings*, 73(5): 473–478.
- Carron, M. A., Tran, V. R., Sugawa, C., and Coticchia, J. M. (2006).** "Identification of *Helicobacter pylori* biofilms in human gastric mucosa." *Journal of Gastrointestinal Surgery*, 10(5): 712–717.
- Celsus ((c.25 A.D.) 1935).** *De Medicina*, volume 2. Heinemann, London.
- Chaignon, P., Sadovskaya, I., Ragunah, C., Ramasubbu, N., Kaplan, J. B., and Jabbouri, S. (2007).** "Susceptibility of staphylococcal biofilms to enzymatic treatments depends on their chemical composition." *Applied Microbiology and Biotechnology*, 75(1): 125–132.

- Chatterjee, C., Paul, M., Xie, L., and van der Donk, W. A. (2005).** "Biosynthesis and mode of action of lantibiotics." *Chemical Reviews*, 105(2): 633–684.
- Chaveerach, P., Lipman, L., and van Knapen, F. (2004).** "Antagonistic activities of several bacteria on in vitro growth of 10 strains of *Campylobacter jejuni/coli*." *International Journal of Food Microbiology*, 90(1): 43–50.
- Cheigh, C.-I. and Pyun, Y.-R. (2005).** "Nisin biosynthesis and its properties." *Biotechnology Letters*, 27(21): 1641–8.
- Chick, H., Shin, H., and Ustunol, Z. (2001).** "Growth and acid production by lactic acid bacteria and bifidobacteria grown in skim milk containing honey." *Journal of Food Science*, 66(3): 478–481.
- Clarke, S. C. (2001).** "Diarrhoeagenic *Escherichia coli* - an emerging problem?" *Diagnostic Microbiology and Infectious Disease*, 41(3): 93–98.
- Cole, S. P., Harwood, L. R., Julia, She, R., and Guiney, D. G. (2004).** "Characterization of monospecies biofilm formation by *Helicobacter pylori*." *Journal of Bacteriology*, 186(10): 3124–3132.
- Colón-González, M., Méndez-Ortiz, M. M., and Membrillo-Hernández, J. (2004).** "Anaerobic growth does not support biofilm formation in *Escherichia coli* K-12." *Research in Microbiology*, 155: 512–521.
- Cookson, B. (2007).** "Hypervirulent strains of *Clostridium difficile*." *Postgraduate Medical Journal*, 83(979): 291–5.
- Cooper, R. (1984).** "Metabolism of methylglyoxal in microorganisms." *Annual Review of Microbiology*, 38: 49–68.
- Cooper, R., Halas, E., and Molan, P. (2002a).** "The efficacy of honey in inhibiting strains of *Pseudomonas aeruginosa* from infected burns." *The Journal of Burn Care & Rehabilitation*, 23(6): 366–370.

- Cooper, R. and Molan, P. (1999).** "The use of honey as an antiseptic in managing *Pseudomonas* infection." *Journal of Wound Care*, 8(4): 161-4.
- Cooper, R., Molan, P., and Harding, K. (1999).** "Antibacterial activity of honey against strains of *Staphylococcus aureus* from infected wounds." *Journal of the Royal Society of Medicine*, 92(6): 283-285.
- Cooper, R., Molan, P., and White, R., editors (2009).** *Honey in Modern Wound Management*. Wounds UK.
- Cooper, R., Molan, P. C., and Harding, K. (2002b).** "The sensitivity to honey of Gram-positive cocci of clinical significance isolated from wounds." *Journal of Applied Microbiology*, 93: 857-863.
- Cooper, R. A. and Jenkins, L. (2008).** "The inhibition of biofilms of *Pseudomonas aeruginosa* with manuka honey." *Wounds*, 54(4): 70.
- Corey, E. J., Czakó, B., and Kürti, L., editors (2007).** *Molecules and Medicine*. Hoboken, N. J.: John Wiley & Sons.
- Corry, J. E., Post, D., and Laisney, M. (1995).** "Culture media for the isolation of Campylobacters." *International Journal of Food Microbiology*, 26: 43-76.
- Costerton, J. W., Lewandowski, Z., Caldwell, D. E., Korber, D. R., and Lappin-Scott, H. M. (1995).** "Microbial biofilms." *Annual Review of Microbiology*, 49: 711-745.
- Craig, W. A. and Gudmundsson, S. (1996).** "Postantibiotic effect." In V. Lorian, editor, "Antibiotics in Laboratory Medicine," pages 296-330. Williams & Wilkins, Baltimore, 4th edition.
- Crane, E. (1979).** *Honey: a Comprehensive Survey*. William Heinemann Ltd., London.

- Cuccurullo, S. J. (2004).** *Physical Medicine and Rehabilitation Board Review*. Demos Medical Publishing, 1st edition.
- Dalhoff, A., editor (1997).** *Pharmacokinetics of Selected Antibacterial Agents*. Basel; Switzerland: Karger Publishers.
- Davis, M. A., Hancock, D. D., and Besser, T. E. (2002).** "Multiresistant clones of *Salmonella enterica*: The importance of dissemination." *The Journal of Laboratory and Clinical Medicine*, 140(3): 135–41.
- De Groote, M. A., Frank, D. N., Dowell, E., Glode, M. P., and Pace, N. R. (2005).** "*Lactobacillus rhamnosus* GG bacteremia associated with probiotic use in a child with short gut syndrome." *The Pediatric Infectious Disease Journal*, 24: 278–280.
- de Man, J. C., Rogosa, M., and Sharpe, M. E. (1960).** "A medium for the cultivation of lactobacilli." *Journal of Applied Bacteriology*, 23: 130–135.
- Delsol, A. A., Sunderland, J., Woodward, M. J., Pumbwe, L., Piddock, L. J. V., and Roe, J. M. (2004).** "Emergence of fluoroquinolone resistance in the native *Campylobacter coli* population of pigs exposed to enrofloxacin." *The Journal of Antimicrobial Chemotherapy*, 53: 872–4.
- Dethlefsen, L., Huse, S., Sogin, M. L., and Relman, D. A. (2008).** "The pervasive effects of an antibiotic on the human gut microbiota, as revealed by deep 16S rRNA sequencing." *PLoS Biology*, 6(11): e280.
- DeVito, J. A., Mills, J. A., and Liu, V. G. (2002).** "An array of target-specific screening strains for antibacterial discovery." *Nature Biotechnology*, 20: 478–483.
- Dial, S., Alrasadi, K., Manoukian, C., Huang, A., and Menzies, D. (2004).** "Risk of *Clostridium difficile* diarrhea among hospital inpatients prescribed proton pump inhibitor: cohort and case-control studies." *Canadian Medical Association Journal*, 171(1): 33–38.

- Dial, S., Delaney, C., Schneider, V., and Suissa, S. (2006).** "Proton pump inhibitor use and risk of community-acquired *Clostridium difficile*-associated disease defined by prescription for oral vancomycin therapy." *Canadian Medical Association Journal*, 175(7): 745–8.
- Domínguez, M., de la Rosa, M., and Borobio, M. (2001).** "Application of a spectrophotometric method for the determination of post-antibiotic effect and comparison with viable counts in agar." *The Journal of Antimicrobial Chemotherapy*, 47(4): 391–398.
- Dowell, S. F. (2004).** "Antimicrobial resistance: is it really that bad?" *Seminars in Pediatric Infectious Diseases*, 15(2): 99–104.
- Doyle, M. and Roman, D. (1982).** "Response of *Campylobacter jejuni* to sodium chloride." *Applied and Environmental Microbiology*, 43(3): 561–5.
- Drenkard, E. (2003).** "Antimicrobial resistance of *Pseudomonas aeruginosa* biofilms." *Microbes and Infection*, 5(13): 1213–1219.
- Drion, S., Wahlen, C., and Taziaux, P. (1988).** "Isolation of *Campylobacter jejuni* from the bile of a cholecystic patient." *Journal of Clinical Microbiology*, 26(10): 2193–2194.
- Droz, S., Chi, B., Horn, E., Steigerwalt, A. G., Whitney, A. M., and Brenner, D. J. (1999).** "*Bartonella koehlerae* sp. nov., isolated from cats." *Journal of Clinical Microbiology*, 37(4): 1117–1122.
- Duddukuri, G. R., Kumar, P. S., Kumar, V. B., and Athota, R. R. (1997).** "Immunosuppressive effect of honey on the induction of allergen-specific humoral antibody response in mice." *International Archives of Allergy and Immunology*, 114: 385–388.
- Dunn, B. E., Cohen, H., and Blaser, M. J. (1997).** "*Helicobacter pylori*." *Clinical Microbiology Reviews*, 10(4): 720–741.



- Dustmann, J. H. (1971).** "Über die Katalaseaktivität in Bienenhonig aus der Tracht der Heidekrautgewächse (Ericaceae)." *Zeitschrift für Lebensmittel-Untersuchung und -Forschung*, 145: 294–295.
- Eagle, H. (1949).** "The recovery of bacteria from the toxic effects of penicillin." *The Journal of Clinical Investigation*, 28(5 Pt 1): 832–6.
- Eagle, H. and Musselman, A. D. (1949).** "The slow recovery of bacteria from the toxic effects of penicillin." *Journal of Bacteriology*, 58(4): 475–90.
- Edwards, R., Brown, J., and Greenwood, D. (1991).** "Turbidimetric study of the effect of inoculum density on the response of *Escherichia coli* to gentamicin under aerobic and anaerobic conditions." *Chemotherapy*, 37(3): 196–201.
- Eggertson, L. (2004).** "*C. difficile* hits Sherbrooke, Que., hospital: 100 deaths." *Canadian Medical Association Journal*, 171(5): 436.
- Eng, R. H., Cherubin, C., Smith, S. M., and Buccini, F. (1985).** "Inoculum effect of beta-lactam antibiotics on Enterobacteriaceae." *Antimicrobial Agents and Chemotherapy*, 28(5): 601–606.
- Erah, P., Goddard, A., Barrett, D., Shaw, P., and Spiller, R. (1997).** "The stability of amoxicillin, clarithromycin and metronidazole in gastric juice: relevance to the treatment of *Helicobacter pylori* infection." *The Journal of Antimicrobial Chemotherapy*, 39(1): 5–12.
- Ethelberg, S., Sørensen, G., Kristensen, B., Christensen, K., Krusell, L., Hempel-Jørgensen, A., Perge, A., and Nielsen, E. M. (2007).** "Outbreak with multi-resistant *Salmonella* Typhimurium DT104 linked to carpaccio, Denmark, 2005." *Epidemiology and Infection*, 135(6): 900–907.
- Ezz El-Arab, A. M., Girgis, S. M., Hegazy, E. M., and Abd El-Khalek, A. B. (2006).** "Effect of dietary honey on intestinal microflora and toxicity of mycotoxins in mice." *BMC Complementary and Alternative Medicine*, 6: 6.

- Falcão, D. P., Mendona, C. P., Scarrassolo, A., De Almeida, B. B., Hart, L., Farmer, L. H., and Farmer, J. J. r. (1972). "Nursery outbreak of severe diarrhoea due to multiple strains of *Pseudomonas aeruginosa*." *Lancet*, 2(7766): 38–40.
- Farina, C., Arosio, M., Mangia, M., and Moioli, F. (2001). "*Lactobacillus casei* subsp. *ramnosus* sepsis in a patient with ulcerative colitis." *Journal of Clinical Gastroenterology*, 33: 251–252.
- Fekete, P. Z. and Nagy, B. (2008). "Salmonella Genomic Island 1 (SGI1) and genetic characteristics of animal and food isolates of *Salmonella typhimurium* DT104 in Hungary." *Acta Veterinaria Hungarica*, 56(1): 5–11.
- Fekety, R. and Shah, A. B. (1993). "Diagnosis and treatment of *Clostridium difficile* colitis." *JAMA : the Journal of the American Medical Association*, 269: 71–75.
- Ferguson, G., Töttemeyer, S., MacLean, M., and Booth, I. (1998). "Methylglyoxal production in bacteria: suicide or survival?" *Archives of Microbiology*, 170: 209–219.
- Field, T. R., White, A., Elborn, J. S., and Tunney, M. M. (2005). "Effect of oxygen limitation on the *in vitro* antimicrobial susceptibility of clinical isolates of *Pseudomonas aeruginosa* grown planktonically and as biofilms." *European Journal of Clinical Microbiology & Infectious Diseases*, 24: 677–687.
- Flahaut, S., Hartke, A., Giard, J.-C., and Auffray, Y. (1997). "Alkaline stress response in *Enterococcus faecalis*: adaptation, cross-protection, and changes in protein synthesis." *Applied and Environmental Microbiology*, 63(2): 812–814.
- Flores, C., Maguilnik, I., Hadlich, E., and Goldani, L. Z. (2003). "Microbiology of choledochal bile in patients with choledocholithiasis admitted

to a tertiary hospital." *Journal of Gastroenterology and Hepatology*, 18(3): 333–336.

**Food and Agriculture Organization and World Health Organization (2002).** "Guidelines for the evaluation of probiotics in food." Technical report, Food and Agriculture Organization and World Health Organization. URL <ftp://ftp.fao.org/es/esn/food/wgreport2.pdf> [accessed: 6/May/2009].

**Food and Drug Administration (2001).** "Agency Response Letter GRAS Notice No. GRN 000065." Technical report. URL <http://www.cfsan.fda.gov/~rdb/opa-g065.html> [accessed: 6/May/2009].

**Fordtran, J. S. (1975).** "Stimulation of active and passive sodium absorption by sugars in the human jejunum." *Journal of Clinical Investigation*, 55: 728–737.

**Franklin, T. J. and Snow, G. A., editors (2005).** *Biochemistry and Molecular Biology of Antimicrobial Drug Action*. New York: Springer.

**Fraser, A., Chandan, V., Yamazaki, H., Brooks, B., and Garcia, M. (1992).** "Simple and economical culture of *Campylobacter jejuni* and *Campylobacter coli* in CO<sub>2</sub> in moist air." *International Journal of Food Microbiology*, 15(3-4): 377–82.

**French, V., Cooper, R., and Molan, P. C. (2005).** "The antibacterial activity of honey against coagulase-negative staphylococci." *The Journal of Antimicrobial Chemotherapy*, 56(1): 228–31.

**Friedmann, M. (2007).** "*Enterobacter sakazakii* in food and beverages (other than infant formula and milk powder)." *International Journal of Food Microbiology*, 116: 1–10.

- Fuchs, P. C., Barry, A. L., and Brown, S. D. (2002).** "In vitro bactericidal activity of daptomycin against staphylococci." *Journal of Antimicrobial Chemotherapy*, 49: 467–470.
- Furihata, C., Sato, Y., Matsushima, T., and Takematsu, M. (1985).** "Induction of ornithine decarboxylase and DNA synthesis in rat stomach mucosa by methylglyoxal." *Carcinogenesis*, 6(1): 91–94.
- Gallardo, E. (1945).** "Sensitivity of bacteria from infected wounds to penicillin: II. Results in one hundred and twelve cases." *War Medicine*, 7: 100–103.
- García Rodríguez, L. A., Ruigómez, A., and Panés, J. (2007).** "Use of acid-suppressing drugs and the risk of bacterial gastroenteritis." *Clinical Gastroenterology and Hepatology*, 5(12): 1418–1423.
- George, H. A., Hoffman, P. S., Smibert, R. M., and Krieg, N. R. (1978a).** "Improved media for growth and aerotolerance of *Campylobacter fetus*." *Journal of Clinical Microbiology*, 8(1): 36–41.
- George, Y., Sadek, L., and Rozeik, F. (1978b).** "The effect of honey on the epithelial attachment." *Journal of Missouri Dental Association*, 24(4): 15–19, 44.
- Gerding, D. N. (1989).** "Disease associated with *Clostridium difficile* infection." *Annals of Internal Medicine*, 110: 255–257.
- Ghosh, M., Talukdar, D., Ghosh, S., Bhattacharyya, N., Ray, M., and Ray, S. (2006).** "In vivo assessment of toxicity and pharmacokinetics of methylglyoxal. Augmentation of the curative effect of methylglyoxal on cancer-bearing mice by ascorbic acid and creatine." *Toxicology and Applied Pharmacology*, 212(1): 45–58.

- Giannella, R. A., Broitman, S. A., and Zamcheck, N. (1972).** "The gastric barrier to microorganisms in man: in vivo and in vitro studies." *Gut*, 13: 251–256.
- Giannella, R. A., Broitman, S. A., and Zamcheck, N. (1973).** "Influence of gastric acidity on bacterial and parasitic enteric infections. A perspective." *Annals of Internal Medicine*, 78(2): 271–6.
- Giovannini, M., Verduci, E., Ghisleni, D., Salvatici, E., Riva, E., and Agostoni, C. (2008).** "*Enterobacter sakazakii*: an emerging problem in paediatric nutrition." *The Journal of International Medical Research*, 36: 394–399.
- Goldschneider, I., Gotschlich, E. C., and Artenstein, M. S. (1969).** "Human immunity to the meningococcus I. The role of humoral antibodies." *Journal of Experimental Medicine*, 129: 1307–1326.
- Goldstein, E. J. C. and Sutter, V. L. (1983).** "Effect of carbon dioxide on erythromycin." *Antimicrobial Agents and Chemotherapy*, 23(2): 325–327.
- Gonnet, M. and Lavie, P. (1960).** "Influence du chauffage sur le facteur antibiotique présent dans les miels." *Annales de l'Abeille (Paris)*, 3(4): 349–364.
- Goodwin, C., Blincow, E., Warren, J., Waters, T., Sanderson, C., and Easton, L. (1985).** "Evaluation of cultural techniques for isolating *Campylobacter pyloridis* from endoscopic biopsies of gastric mucosa." *Journal of Clinical Pathology*, 38(10): 1127–31.
- Goosney, D. L., Gruenheid, S., and Finlay, B. B. (2000).** "Gut feelings: enteropathogenic *E. coli* (EPEC) interactions with the host." *Annual Review of Cell and Developmental Biology*, 16: 173–189.
- Gorbach, S. L., Plaut, A. G., Nahas, L., Weinstein, L., Spanknebel, G., and Levitan, R. (1967).** "Studies of intestinal microflora. II. Microorganisms

of the small intestine and their relations to oral and fecal flora." *Gastroenterology*, 53: 856–867.

**Gorman, R. and Adley, C. (2004).** "An evaluation of five preservation techniques and conventional freezing temperatures of  $-20^{\circ}\text{C}$  and  $-85^{\circ}\text{C}$  for long-term preservation of *Campylobacter jejuni*." *Letters in Applied Microbiology*, 38: 306–310.

**Gottfredsson, M., Erlendsdóttir, H., Gudmundsson, A., and Gudmundsson, S. (1995).** "Different patterns of bacteria DNA synthesis during postantibiotic effect." *Antimicrobial Agents and Chemotherapy*, 39(6): 1314–1319.

**Gottfredsson, M., Erlendsdóttir, H., Kolka, R., Gudmundsson, A., and Gudmundsson, S. (1993).** "Ultrastructural alterations of bacteria during the postantibiotic effect." *Chemotherapy*, 39(3): 153–162.

**Gray, J. A. and Trueman, A. M. (1971).** "Severe salmonella gastroenteritis associated with hypochlorhydria." *Scottish Medical Journal*, 16: 255–258.

**Gresham, A. C. J. (1996).** "An old disease of increasing significance - Salmonella infection in pigs in Great Britain." *Pig Journal*, 37: 59–64.

**Grill, J. P., Cayuela, C., Antoine, J. M., and Schneider, F. (2000).** "Isolation and characterization of a *Lactobacillus amylovorus* mutant depleted in conjugated bile salt hydrolase activity: relation between activity and bile salt resistance." *Journal of Applied Microbiology*, 89(4): 553–563.

**Gunther, N. W. I. and Chen, C.-Y. (2009).** "The biofilm forming potential of bacterial species in the genus *Campylobacter*." *Food Microbiology*, 26: 44–51.

**György, P. (1953).** "A hitherto unrecognized biochemical difference between human milk and cow's milk." *Pediatrics*, 11: 98–108.

- Haffejee, I. and Moosa, A. (1985).** "Honey in the treatment of infantile gastroenteritis." *British Medical Journal*, 290(6485): 1866–7.
- Hall, H. K., Karem, K. L., and Foster, J. W. (1995).** "Molecular responses of microbes to environmental pH stress." *Advances in Microbial Physiology*, 37: 229–272.
- Hall, I. and O'Toole, E. (1935).** "Intestinal flora in new-born infants: with a description of a new pathogenic anaerobe, *Bacillus difficilis*." *American Journal of Diseases of Children*, 49: 390–402.
- Hanninen, M. (1991).** "Sensitivity of *Helicobacter pylori* to different bile salts." *European Journal of Clinical Microbiology & Infectious Diseases*, 10(6): 515–8.
- Harsch, I. A., Hahn, E. G., and Konturek, P. C. (2001).** "Pseudomembranous colitis after eradication of *Helicobacter pylori* infection with a triple therapy." *Medical Science Monitor*, 7(4): 751–754.
- Hasegawa, M., Amano, A., Muraoka, H., Kobayashi, I., Kimoto, M., Kato, M., Fujioka, T., and Nasu, M. (2002).** "A multicenter study of a new *Helicobacter pylori* selective medium, Columbia horse blood agar HP." *Kansenshogaku Zasshi*, 76(5): 341–346.
- Hasler, W. L. and Owyang, C. (2005).** *Harrison's Principles of Internal Medicine*, chapter 271, pages 1725–1730. McGraw-Hill, 16th edition.
- Hill, D., Rose, B., Pajkos, A., Robinson, M., Bye, P., Bell, S., Mark, E., Thompson, B., MacLeod, C., Aaron, S. D., and Harbour, C. (2005).** "Antibiotic susceptibilities of *Pseudomonas aeruginosa* isolates derived from patients with cystic fibrosis under aerobic, anaerobic, and biofilm conditions." *Journal of Clinical Microbiology*, 43(10): 5085–5090.
- Hillier, S. and Moncla, B. J. (1991).** *Manual of Clinical Microbiology*, chapter 51, page 525. American Society for Microbiology, 15th edition.

- Hodgson, M. J. (1989).** *Investigation of the antibacterial action spectrum of some honeys.* Master's thesis, University of Waikato, Hamilton, New Zealand.
- Hornick, R. M., Music, S. I., and Wenzel, R. (1971).** "The broad street pump revisited; response of volunteers to ingested cholera vibrios." *The Bulletin of the New York Academy of Medicine*, 47: 1181–1191.
- Hung, D. T., Zhu, J., Sturtevant, D., and Mekalanos, J. J. (2006).** "Bile acids stimulate biofilm formation in *Vibrio cholerae*." *Molecular Microbiology*, 59(1): 193–201.
- Hunt, J. M., Abeyta, C., and Tran, T. (2001).** "Bacteriological analytical manual." Technical report, Food and Drug Association and Centre for Food Safety and Applied Nutrition. URL <http://www.cfsan.fda.gov/ebam/bam-7.html> [accessed: 6/May/2009].
- Inoue, Y. and Kimura, A. (1995).** "Methylglyoxal and regulation of its metabolism in microorganisms." *Advances in Microbial Physiology*, 37: 177–227.
- Institute of Environmental Science and Research (2008).** "Notifiable and other diseases in New Zealand - annual report 2007." Annual report FW 08034, Population and Environmental Health Group, Institute of Environmental Science and Research.
- Irie, Y., Tateda, K., Matsumoto, T., Miyazaki, S., and Yamaguchi, K. (1997).** "Antibiotic MICs and short time-killing against *Helicobacter pylori*: therapeutic potential of kanamycin." *Journal of Antimicrobial Chemotherapy*, 40: 235–240.
- Iuchi, S. and Weiner, L. (1996).** "Cellular and molecular physiology of *Escherichia coli* in the adaptation to aerobic environments." *Journal of Biochemistry*, 120(6): 1055–1063.



- Iversen, C., Mullane, N., McCardell, B., Tall, B. D., Lehner, A., Fanning, S., Stephan, R., and Joosten, H. (2008). "Cronobacter gen. nov., a new genus to accommodate the biogroups of *Enterobacter sakazakii*, and proposal of *Cronobacter sakazakii* gen. nov., comb. nov., *Cronobacter malonaticus* sp. nov., *Cronobacter turicensis* sp. nov., *Cronobacter muytjensii* sp. nov., *Cronobacter dublinensis* sp. nov., *Cronobacter* genomospecies 1, and of three subspecies, *Cronobacter dublinensis* subsp. *dublinensis* subsp. nov., *Cronobacter dublinensis* subsp. *lausannensis* subsp. nov. and *Cronobacter dublinensis* subsp. *lactaridi* subsp. nov." *International Journal of Systematic and Evolutionary Microbiology*, 58(Pt 6): 1442–1448.
- Jacobs, M. R. (2003). "How can we predict bacterial eradication?" *International Journal of Infectious Diseases*, 7 Suppl 1: S13–20.
- James, O. B. O., Segree, W., and Ventura, A. K. (1972). "Some anti-bacterial properties of Jamaican honey." *West Indian Medical Journal*, 21(7): 7–17.
- Jansen, J. E. and Bremmelgaard, A. (1986). "Effect of culture medium and carbon dioxide concentration on growth of anaerobic bacteria and medium pH." *Acta Pathologica et Microbiologica Scandinavica - Section B*, 94(5): 319–323.
- Jenkins, D., Schultz, J., and Matin, A. (1988). "Starvation-induced cross protection against heat or H<sub>2</sub>O<sub>2</sub> challenge in *Escherichia coli*." *Journal of Bacteriology*, 170(9): 3910–4.
- Jernberg, C., Löfmark, S., Edlund, C., and Jansson, J. K. (2007). "Long-term ecological impacts of antibiotic administration on the human intestinal microbiota." *The ISME Journal*, 1: 56–66.
- Jett, B. D., Hatter, K. L., Huycke, M. M., and Gilmore, M. S. (1997). "Simplified agar plate method for quantifying viable bacteria." *Biotechniques*, 23(4): 648–50.

- Jiang, X. and Doyle, M. P. (2000).** "Growth supplements for *Helicobacter pylori*." *Journal of Clinical Microbiology*, 38(5): 1984–7.
- Joerger, R. (2003).** "Alternatives to antibiotics: bacteriocins, antimicrobial peptides and bacteriophages." *Poultry Science*, 82(4): 640–647.
- Jones, D., Sutcliffe, E., Rios, R., Fox, A., and Curry, A. (1993).** "*Campylobacter jejuni* adapts to aerobic metabolism in the environment." *Journal of Medical Microbiology*, 38(2): 145–150.
- Jones, R. N. (2001).** "Resistance patterns among nosocomial pathogens: trends over the past few years." *Chest*, 119(2): 397S–404S.
- Joseph, R., Demeyer, D., Vanrenterghem, D., van den Berg, R., Kuijper, E. J., and Delmée, M. (2005).** "First isolation of *Clostridium difficile* PCR ribotype O27, toxin III in Belgium." *Eurosurveillance Weekly*, 10: E051020.4. URL <http://www.eurosurveillance.org/ew/2005/051020.asp#4> [accessed: 6/May/2009].
- Joshua, G., Guthrie, C., Karlyshev, A., and Wren, B. (2006).** "Biofilm formation in *Campylobacter jejuni*." *Microbiology*, 152: 387–396.
- Kajiwara, S., Gandhi, H., and Ustunol, Z. (2002).** "Effect of honey on the growth of and acid production by human intestinal *Bifidobacterium* spp.: an *in vitro* comparison with commercial oligosaccharides and inulin." *Journal of Food Protection*, 65(1): 214–8.
- Kalapos, M. P. (1999).** "Methylglyoxal in living organisms: chemistry, biochemistry, toxicology and biological implications." *Toxicology Letters*, 110(3): 145–75.
- Kalapos, M. P., Schaff, Z., Garzó, T., Antoni, F., and Mandl, J. (1991).** "Accumulation of phenols in isolated hepatocytes after pretreatment with methylglyoxal." *Toxicology Letters*, 58(2): 181–191.

- Kandell, R. and Bernstein, C. (1991).** "Bile salt/acid induction of DNA damage in bacterial and mammalian cells: implications for colon cancer." *Nutrition and Cancer*, 16(3-4): 227–238.
- Kandil, A., El-Banby, M., Abdel-Wahed, K., Abdel-Gawwad, M., and Fayeze, M. (1987).** "Curative properties of true floral and false nonfloral honeys on induced gastric ulcer." *Journal of Drug Research (Cairo)*, 1-2: 103–106.
- Karmali, M. A. (2004).** "Infection by Shiga toxin-producing *Escherichia coli*: and overview." *Molecular Biotechnology*, 26(2): 117–122.
- Karmali, M. A. and Fleming, P. C. (1979).** "Application of the Fortner principle to isolation of *Campylobacter* from stools." *Journal of Clinical Microbiology*, 10(2): 245–247.
- Kasper, D. L., Braunwald, E., Fauci, A. S., Hauser, S. L., Longo, D. L., and Jameson, J. L. (2005).** *Harrison's Principles of Internal Medicine*. McGraw-Hill, 16th edition.
- Katikireddi, V. (2005).** "UK launches inquiry into *Clostridium difficile* outbreak." *Canadian Medical Association Journal*, 173(2): 138.
- Keil, B., editor (1992).** *Specificity of Proteolysis*. Berlin ; New York : Springer-Verlag.
- Keilin, D. and Hartree, E. F. (1948).** "Properties of glucose oxidase (notatin)." *The Biochemical Journal*, 42(2): 221–229.
- Kelly, C. P., Pothoulakis, C., and LaMont, J. T. (1994).** "*Clostridium difficile* colitis." *The New England Journal of Medicine*, 330: 257–262.
- Kienitz, M. (1979).** "Outbreaks and sporadic cases of enteritis due to *Pseudomonas aeruginosa* in premature babies and infants (author's transl)." *Infection*, 7(Suppl 2): S231–S235.

- King, C. K., Glass, R., Bresee, J. S., and Duggan, C. (2003). "Managing acute gastroenteritis among children oral rehydration, maintenance, and nutritional therapy." *MMWR. Morbidity and Mortality Weekly Report*, 52(RR-16): 1–16. URL <http://www.cdc.gov/mmwr/PDF/rr/rr5216.pdf> [accessed: 6/May/2009].
- Kishima, M., Uchida, I., Namimatsu, T., Osumi, T., Takahashi, S., Tanaka, K., Aoki, H., Matsuura, K., and Yamamoto, K. (2008). "Nationwide surveillance of salmonella in the faeces of pigs in Japan." *Zoonoses and Public Health*, 55(3): 139–144.
- Knoop, F., Owens, M., and Crocker, I. (1993). "*Clostridium difficile*: clinical disease and diagnosis." *Clinical Microbiology Reviews*, 6(3): 251–265.
- Komatsu, M., Kato, H., Aihara, M., Shimakawa, K., Iwasaki, M., Nagasaka, Y., Fukuda, S., Matsuo, S., Arakawa, Y., Watanabe, M., and Iwatani, Y. (2003). "High frequency of antibiotic-associated diarrhea due to toxin A-negative, toxin B-positive *Clostridium difficile* in a hospital in Japan and risk factors for infection." *European Journal of Clinical Microbiology & Infectious Diseases*, 22(9): 525–9.
- Kubo, N., Kochi, S., Ariyama, I., Murata, M., Furusyo, N., and Hayashi, J. (2006). "Pseudomembranous colitis after *Helicobacter pylori* eradication therapy." *Kansenshogaku Zasshi*, 80: 51–55.
- Kuijper, E., Coignard, B., Tüll, P., for *Clostridium difficile*, E. S. G., States, E. M., for Disease Prevention, E. C., and Control (2006). "Emergence of *Clostridium difficile*-associated disease in North America and Europe." *Clinical Microbiology and Infection*, 12(Suppl. 6): 2–18.
- Kuijper, E., Debast, S. B., van Kregten, E., Vaessen, N., Notermans, D., and van den Broek, P. J. (2005). "*Clostridium difficile* ribotype O27, toxin

- III in the Netherlands." *Nederlands Tijdschrift voor Geneeskunde*, 49: 2087–2089.
- Kunz, A. N., Noel, J. M., and Fairchok, M. P. (2004).** "Two cases of *Lactobacillus* bacteremia during probiotic treatment of short gut syndrome." *Journal of Pediatric Gastroenterology and Nutrition*, 38: 457–458.
- Lake, R., Hudson, A., and Cressey, P. (2004).** "Risk profile: *Yersinia enterocolitica* in pork." Risk profile FW0328, Institute of Environmental Science & Research.
- Lamont, R. J., Burne, R. A., Lantz, M. S., and Leblanc, D. J., editors (2006).** *Oral Microbiology and Immunology*. ASM Press, Washington, D. C.
- Lau, C. F., Hui, P. K., Fung, T. T., Tung, S. Y., Wong, A. M., Loo, C. K., and Lam, K. M. (2001).** "Pseudomembranous colitis without diarrhoea following *Helicobacter pylori* eradication therapy." *Hospital Medicine*, 62(7): 431–433.
- Lee, K. E. and Lee, Y. (2007).** "Isolation of multidrug-resistant *Salmonella typhimurium* DT104 from swine in Korea." *Journal of Microbiology*, 45(6): 590–592.
- Leonard, J., Marshall, J. K., and Moayyedi, P. (2007).** "Systematic review of the risk of enteric infection in patients taking acid suppression." *The American Journal of Gastroenterology*, 102(9): 2047–2056.
- Lerrer, B., Zinger-Yosovich, D., Avrahami, B., and Gilboa-Garber, N. (2007).** "Honey and royal jelly, like human milk, abrogate lectin-dependent infection-preceding *Pseudomonas aeruginosa* adhesion." *The ISME Journal*, 1: 149–155.
- Ley, R., Peterson, D., and Gordon, J. (2006).** "Ecological and evolutionary forces shaping microbial diversity in the human intestine." *Cell*, 124(4): 837–848.

- Leyer, G. J. and Johnson, E. A. (1993).** "Acid adaptation induces cross-protection against environmental stresses in *Salmonella typhimurium*." *Applied and Environmental Microbiology*, 59(6): 1842–1847.
- Lineaweaver, W., McMorris, S., Soucy, D., and Howard, R. (1985).** "Cellular and bacterial toxicities of topical antimicrobials." *Plastic and Reconstructive Surgery*, 75(3): 394–6.
- Linnet, P. (1996).** "Honey for equine diarrhoea." *Control and Therapy*, page 906.
- Little, C. L., Richardson, J. F., Owen, R. J., de Pinna, E., and Threlfall, E. J. (2008).** "*Campylobacter* and *Salmonella* in raw red meats in the United Kingdom: prevalence, characterization and antimicrobial resistance pattern, 2003-2005." *Food Microbiology*, 25(3): 538–543.
- Loo, V. G., Poirier, L., Miller, M. A., Oughton, M., Libman, M. D., Michaud, S., Bourgault, A.-M., Nguyen, T., Frenette, C., Kelly, M., René, P., Monczak, Y., and Dascal, A. (2005).** "A predominantly clonal multi-institutional outbreak of *Clostridium difficile*-associated diarrhea with high morbidity and mortality." *The New England Journal of Medicine*, 353(23): 2442–2449.
- Louis, P., Scott, K., Duncan, S., and Flint, H. (2007).** "Understanding the effects of diet on bacterial metabolism in the large intestine." *Journal of Applied Microbiology*, 102: 1197–1208.
- Luechtefeld, N. W., Reller, L. B., Blaser, M. J., and Wang, W.-L. L. (1982).** "Comparison of atmospheres of incubation for primary isolation of *Campylobacter fetus* subsp. *jejuni* from animal specimens: 5% oxygen versus candle jar." *Journal of Clinical Microbiology*, 15(1): 53–7.

- Lusby, P. E., Coombes, A. L., and Wilkinson, J. M. (2005).** "Bactericidal activity of different honeys against pathogenic bacteria." *Archives of Medical Research*, 36(5): 464–7.
- Mah, T. F., Pitts, B., Pellock, B., Walker, G. C., Stewart, P. S., and O'Toole, G. A. (2003).** "A genetic basis for *Pseudomonas aeruginosa* biofilm antibiotic resistance." *Nature*, 426(6964): 306–310.
- Mahgoub, A. A., El-Medany, A. H., Hagar, H. H., and Sabah, D. M. (2002).** "Protective effect of natural honey against acetic acid-induced colitis in rats." *Tropical Gastroenterology*, 23(2): 82–7. URL [http://www.ncbi.nlm.nih.gov/entrez/query.fcgi?cmd=Retrieve&db=PubMed&dopt=Citation&list\\_uids=12632976](http://www.ncbi.nlm.nih.gov/entrez/query.fcgi?cmd=Retrieve&db=PubMed&dopt=Citation&list_uids=12632976) [accessed: 6/May/2009].
- Majtán, J., Majtánová, L., Xu, M., and Majtán, V. (2008).** "In vitro effect of subinhibitory concentration of antibiotics on biofilm formation by clinical strains of *Salmonella enterica* serovar Typhimurium isolated in Slovakia." *Journal of Applied Microbiology*, 104(5): 1294–1301.
- Manning, S. D., Motiwala, A. S., Springman, A. C., Qi, W., Lacher, D. W., Ouellette, L. M., Mladonicky, J. M., Somsel, P., Rudrik, J. T., Dietrich, S. E., Zhang, W., Swaminathan, B., Alland, D., and Whittam, T. S. (2008).** "Variation in virulence among clades of *Escherichia coli* O157:H7 associated with disease outbreaks." *Proceedings of the National Academy of Sciences of the United States of America*, 105(12): 4868–4873.
- Martini, F. H., editor (2001).** *Fundamentals of Anatomy & Physiology*. Prentice Hall, 5th edition.
- Mavric, E., Wittmann, S., Barth, G., and Henle, T. (2008).** "Identification and quantification of methylglyoxal as the dominant antibacterial constituent of Manuka (*Leptospermum scoparium*) honeys from New Zealand." *Molecular Nutrition & Food Research*, 52(4): 483–489.

- McAuliffe, R. P., Olivia nd Ross and Hill, C. (2001).** "Lantibiotics: structure, biosynthesis and mode of action." *FEMS Microbiology Reviews*, 25: 285–308.
- McCulloch, E. C. (1945).** *Disinfection and Sterilization*. Henry Kimpton, London, 2nd edition.
- McGovern, D. P., Abbas, S. Z., Vivian, G., and Dalton, H. R. (1999).** "Manuka honey against *Helicobacter pylori*." *Journal of the Royal Society of Medicine*, 92(8): 439.
- McMullin, B. B., Chittock, D. R., Roscoe, D. L., Garcha, H., Wang, L., and Miller, C. C. (2005).** "The antimicrobial effect of nitric oxide on the bacteria that cause nosocomial pneumonia in mechanically ventilated patients in the intensive care unit." *Respiratory Care*, 50(11): 1451–6.
- McNulty, C., Dent, J., Uff, J., Gear, M., and Wilkinson, S. (1989).** "Detection of *Campylobacter pylori* by the biopsy urease test: an assessment in 1445 patients." *Gut*, 30(8): 1058–62.
- Meldrum, R., Smith, R., and Wilson, I. (2006).** "Three-year surveillance program examining the prevalence of *Campylobacter* and *Salmonella* in whole retail raw chicken." *Journal of Food Protection*, 69(4): 928–31.
- Merrell, D. S. and Camilli, A. (2002).** "Acid tolerance of gastrointestinal pathogens." *Current Opinion in Microbiology*, 5: 51–55.
- Meyer, A., Stallmach, T., Goldenberger, D., and Altwegg, M. (1997).** "Lethal maternal sepsis caused by *Campylobacter jejuni*: pathogen preserved in placenta and identified by molecular methods." *Modern Pathology*, 10(12): 1253–6.
- Miller, T. E. (1969).** "Killing and lysis of Gram-negative bacteria through the synergistic effect of hydrogen peroxide, ascorbic acid, and lysozyme." *Journal of Bacteriology*, 98(3): 949–955.



- Molan, P. (2006).** "The evidence supporting the use of honey as a wound dressing." *The International Journal of Lower Extremity Wounds*, 5(1): 40–54.
- Molan, P. (2008a).** "An explanation of why the MGO level in manuka honey does not show the antibacterial activity." *New Zealand BeeKeeper*, pages 11–13.
- Molan, P. (2008b).** "Why using the level of the active component in manuka honey to replace the UMF rating is misleading." *New Zealand BeeKeeper*, pages 6–7.
- Molan, P. C. (1992a).** "The antibacterial activity of honey. 1. The nature of the antibacterial activity." *Bee World*, 73(1): 5–28.
- Molan, P. C. (1992b).** "The antibacterial activity of honey. 2. Variation in the potency of the antibacterial activity." *Bee World*, 73(2): 59–76.
- Molan, P. C. (1995).** "The antibacterial properties of honey." *Chemistry in New Zealand*, 59(4): 10–14.
- Molan, P. C. (1996).** "Authenticity of honey." In P. R. Ashurst and M. J. Dennis, editors, "Food Authentication," pages 259–303. Blackie Academic and Professional, London.
- Molan, P. C. (1999).** "Why honey is effective as a medicine. 1. Its use in modern medicine." *Bee World*, 80(2): 80–92.
- Molan, P. C. (2001).** "Why honey is effective as a medicine. 2. The scientific explanation of its effects." *Bee World*, 82(1): 22–40.
- Molan, P. C. (2009).** *New Strategies Combating Bacterial Infection*, chapter 9. Honey: antimicrobial actions and role in disease management, pages 229–253. Wiley VCH, Weinheim.
- Molan, P. C. and Russell, K. M. (1988).** "Non-peroxide antibacterial activity in some New Zealand honeys." *Journal of Apicultural Research*, 27: 62–67.

- Molla, B., Miko, A., Pries, K., Hildebrandt, G., Kleer, J., Schroeter, A., and Helmuth, R. (2007).** "Class 1 integrons and resistance gene cassettes among multidrug resistant *Salmonella* serovars isolated from slaughter animals and foods of animal origin in Ethiopia." *Acta Tropica*, 103(2): 142–149.
- Moore, J. and Madden, R. (2000).** "The effect of thermal stress on *Campylobacter coli*." *Journal of Applied Microbiology*, 89(5): 892–9.
- Morshed, M., Islam, M., Zinnah, F., Rumi, M., Ahmad, M., and Huq, F. (1995).** "Growth of *Helicobacter pylori* in candle jar." *Lancet*, 346(88973): 511.
- Mundo, M. A., Padilla-Zakour, O. I., and Worobo, R. W. (2004).** "Growth inhibition of foodborne pathogens and food spoilage organisms by select raw honeys." *International Journal of Food Microbiology*, 97(1): 1–8.
- Murphy, B. P., Buckley, J. F., O'Connor, E. M., Gilroy, D., and Fanning, S. (2008).** "Comparison of *Salmonella* species recovered from Irish liquid milk product holdings with temporal clinical veterinary isolates." *International Journal of Hygiene and Environmental Health*, 211(3-4): 283–291.
- Murray, P. R. and Baron, E. J. (2003).** *Manual of Clinical Microbiology*. ASM Press, Washington, D.C., 8th edition.
- Musher, D. M., Aslam, S., Logan, N., Nallacheru, S., Bhaila, I., Borchert, F., and Hamill, R. J. (2005).** "Relatively poor outcome after treatment of *Clostridium difficile* colitis with metronidazole." *Clinical Infectious Diseases*, 40(11): 1586–1590.
- Nachamkin, I. and Blaser, M. J., editors (2000).** *Campylobacter*. ASM Press, 2nd edition.

- Nanavaty, J., Mortensen, J. E., and Shryock, T. R. (1998).** "The effects of environmental conditions on the *in vitro* activity of selected antimicrobial agents against *Escherichia coli*." *Current Microbiology*, 36: 212–215.
- Nasuti, C., Gabbianelli, R., Falcioni, G., and Cantalamessa, F. (2006).** "Antioxidative and gastroprotective activities of anti-inflammatory formulations derived from chestnut honey in rats." *Nutrition Research*, 26(3): 130–137.
- Natarajan, S., Williamson, D., Grey, J., Harding, K., and Cooper, R. (2001).** "Healing of an MRSA-colonized, hydroxyurea-induced leg ulcer with honey." *Journal of Dermatological Treatment*, 12: 33–36.
- National Committee for Clinical Laboratory Standards (2000).** *Methods for dilution antimicrobial susceptibility tests for bacteria that grow aerobically: Approved standard-Fifth edition (M7-A5)*, volume 20. NCCLS, Wayne, Pennsylvania, USA, 5th edition.
- National Committee for Clinical Laboratory Standards (2002).** *Performance standards for antimicrobial disk and dilution susceptibility tests for bacteria isolated from animals: approved standard (M31-A2)*. NCCLS, Wayne, Pennsylvania, USA, 2nd edition.
- Nauschuetz, W. (1998).** "Emerging foodborne pathogens: enterohemorrhagic *Escherichia coli*." *Clinical Laboratory Science: Journal of the American Society for Medical Technology*, 11(5): 298–304.
- Nawaz, A., Mohammed, I., Ahsan, K., Karakurum, A., Hadjiyane, C., and Pellecchia, C. (1998).** "*Clostridium difficile* colitis associated with treatment of *Helicobacter pylori* infection." *The American Journal of Gastroenterology*, 93(7): 1175–1176.

- Nemet, I., Varga-Defterdarović, L., and Turk, Z. (2006).** "Methylglyoxal in food and living organisms." *Molecular Nutrition & Food Research*, 50(12): 1105–17.
- Nicolau, D. (2001).** "Predicting antibacterial response from pharmacodynamic and pharmacokinetic profiles." *Infection*, 29 Suppl 2: 11–5.
- Nicolau, D. P. (2003).** "Optimizing outcomes with antimicrobial therapy through pharmacodynamic profiling." *Journal of Infection and Chemotherapy*, 9(4): 292–6.
- Notermans, D. W., van Pelt, W., Kivi, M., van de Giessen, A. W., Wannet, W. J., and Bosman, A. (2005).** "Sharp increase of infections with *Salmonella* serotype Typhimurium DT104 in the Netherlands." *Nederlands Tijdschrift voor Geneeskunde*, 149(53): 2992–2994.
- Obi, C., Ugoji, E., Edun, S., Lawal, S., and Anyiwo, C. (1994).** "The antibacterial effect of honey on diarrhoea causing bacterial agents isolated in Lagos, Nigeria." *African Journal of Medicine and Medical Science*, 23(3): 257–60.
- Odenholt, I. (2001).** "Pharmacodynamic effects of subinhibitory antibiotic concentrations." *International Journal of Antimicrobial Agents*, 17(1): 1–8.
- Odenholt-Tornqvist, I., Löwdin, E., and Cars, O. (1991).** "Pharmacodynamic effects of subinhibitory concentrations of  $\beta$ -lactam antibiotics in vitro." *Antimicrobial Agents and Chemotherapy*, 35(9): 1834–9.
- O'Driscoll, B., Gahan, C. G., and Hill, C. (1996).** "Adaptive acid tolerance response in *Listeria monocytogenes*: isolation of an acid-tolerant mutant which demonstrates increased virulence." *Applied and Environmental Microbiology*, 62(5): 1693–1698.
- Oliver, J. D. (2005).** "The viable but nonculturable state in bacteria." *Journal of Microbiology*, 43(special issue): 93–100.

- Osato, M. S., Reddy, S. G., and Graham, D. Y. (1999).** "Osmotic effect of honey on growth and viability of *Helicobacter pylori*." *Digestive Diseases and Sciences*, 44(3): 462–4.
- Ossanna, P. J., Test, S. T., Matheson, N. R., Regiani, S., and Weiss, S. J. (1986).** "Oxidative regulation of neutrophil elastase-alpha-1-proteinase inhibitor interactions." *Journal of Clinical Investigation*, 77: 1939–1951.
- Padungton, P. and Kaneene, J. B. (2003).** "*Campylobacter* spp. in human, chickens, pigs and their antimicrobial resistance." *The Journal of Veterinary Medical Science*, 65(2): 161–170.
- Pankuch, G., Jacobs, M., and Appelbaum, P. (2003).** "Postantibiotic effects of daptomycin against 14 staphylococcal and pneumococcal clinical isolates." *Antimicrobial Agents and Chemotherapy*, 47(9): 3012–4.
- Paramithiotis, S., Melissari, I., and Drosinos, E. H. (2006).** "In vitro assessment of properties associated with the survival through the gastrointestinal tract of staphylococci isolated from traditional sausage fermentation." *Food Microbiology*, 23(7): 663–71.
- Parashar, U. D. and Glass, R. I. (2005).** *Harrison's Principles of Internal Medicine*, chapter 174, page 1140. McGraw-Hill.
- Parker, R. and Marsh, H. C. (1946).** "The action of penicillin on *Staphylococcus*." *Journal of Bacteriology*, 51(2): 181–6.
- Paterson, D. L. and Bonomo, R. A. (2005).** "Extended-spectrum  $\beta$ -lactamases: a clinical update." *Clinical Microbiology Reviews*, 18(4): 657–86.
- Payne, C. M., Crowley, C., Washo-Stultz, D., Briehl, M., Bernstein, H., Bernstein, C., Beard, S., Holubec, H., and Warneke, J. (1998).** "The stress-response proteins poly(ADP-ribose) polymerase and NF-kappaB protect against bile salt-induced apoptosis." *Cell Death and Differentiation*, 5(7): 623–636.

- Peetermans, W., De Man, F., Moerman, P., and van de Werf, F. (2000).** "Fatal prosthetic valve endocarditis due to *Campylobacter fetus*." *The Journal of Infection*, 41(2): 180–2.
- Pennie, R. A., Zunino, J., Rose, C. J., and Guerrant, R. L. (1984).** "Economical, simple method for production of the gaseous environment required for cultivation of *Campylobacter jejuni*." *Journal of Clinical Microbiology*, 20(3): 320–2.
- Pépin, J., Alary, M. E., Valiquette, L., Raiche, E., Ruel, J., Fulop, K., Godin, D., and Bourassa, C. (2005).** "Increasing risk of relapse after treatment of *Clostridium difficile* colitis in Quebec, Canada." *Clinical Infectious Diseases*, 40(11): 1591–1597.
- Peppin, G. J. and Weiss, S. J. (1986).** "Activation of the endogenous metalloproteinase, gelatinase, by triggered human neutrophils." *Proceedings of the National Academy of Sciences of the United States of America*, 83: 4322–4326.
- Pindera, L. (2007).** "*C. difficile* inquest too narrow as "Quebec strain" goes international." *Canadian Medical Association Journal*, 176(7): 915–916.
- Pocock, G. and Richards, C. D. (2006).** *Human Physiology*. Oxford University Press, 3rd edition.
- Pong, A. and Bradley, J. S. (2004).** "Clinical challenges of nosocomial infections caused by antibiotic-resistant pathogens in pediatrics." *Seminars in Pediatric Infectious Diseases*, 15(1): 21–9.
- Popovic-Uroic, T. and Sterk-Kuzmanovic, N. (1992).** "Comparison of two simple microaerobic atmospheres for cultivation of thermophilic campylobacters." *Journal of Clinical Pathology*, 45(1): 87–8.
- Poppe, C., Smart, N., Khakhria, R., Johnson, W., Spika, J., and Prescott, J. (1998).** "*Salmonella typhimurium* DT104: a virulent and drug-resistant pathogen." *The Canadian Veterinary Journal*, 39(9): 559–565.

- Porco, F. V. and Visconte, E. B. (1999).** “*Pseudomonas aeruginosa* as a cause of infectious diarrhea successfully treated with oral ciprofloxacin.” *The Annals of Pharmacotherapy*, 29(11): 1122–1123.
- Poxton, I., McCoubrey, J., and Blair, G. (2001).** “The pathogenicity of *Clostridium difficile*.” *Clinical Microbiology and Infection*, 7(8): 421–7.
- Pruitt, K. M. and Reiter, B. (1985).** *The Lactoperoxidase System: Chemistry and Biological Significance*, chapter Biochemistry of peroxidase system: antimicrobial effects, pages 144–178. Marcel Dekker, New York.
- Punsalang, A. P. J. and Sawyer, W. D. (1973).** “Role of pili in the virulence of *Neisseria gonorrhoeae*.” *Infection and Immunity*, 8(2): 255–263.
- Qadri, F., Svennerholm, A.-M., Faruque, A., and Sack, R. (2005).** “Enterotoxigenic *Escherichia coli* in developing countries: epidemiology, microbiology, clinical features, treatment, and prevention.” *Clinical Microbiology Reviews*, 18(3): 465–83.
- Qarah, S., Cunha, B. A., Dua, P., Lessnau, K.-D., and Madappa, T. (2008).** “*Pseudomonas aeruginosa* infections.” *eMedicine*. URL <http://emedicine.medscape.com/article/226748-overview>[accessed:6/May/2009].
- R Development Core Team (2008).** *R: A language and environment for statistical computing*. R Foundation for Statistical Computing, Vienna, Austria, 2.5.0 edition. URL <http://www.R-project.org>. ISBN 3-900051-07-0.
- Rai, R. and Rai, S. (2002).** “Pseudomembranous colitis requiring surgical intervention following triple therapy for *Helicobacter pylori* eradication.” *ANZ Journal of Surgery*, 72(12): 917–919.
- Rajagopalan, N. and Lindenbaum, S. (1982).** “The binding of Ca<sup>2+</sup> to taurine and glycine-conjugated bile salt micelles.” *Biochimica et Biophysica Acta*, 711(1): 66–74.

- Rajagopalan, N. and Lindenbaum, S. (1984).** "Counter-ion binding by bile acid solutions." *Hepatology*, 4(5 Suppl): 110S–114S.
- Rautio, M., Jousimies-Somer, H., and Kauma, H. (1999).** "Liver abscess due to a *Lactobacillus rhamnosus* strain indistinguishable from *L. rhamonosus* strain GG." *Clinical Infectious Diseases*, 28: 1159–1160.
- Reddy, C. A., Beveridge, T. J., Breznak, J. A., Marzluf, G. A., Schmidt, T. M., and Snyder, L. R., editors (2007).** *Methods for General and Molecular Microbiology*. ASM Press, 3rd edition.
- Reezal, A., McNeil, B., and Anderson, J. (1998).** "Effect of low-osmolality nutrient media on growth and culturability of *Campylobacter* species." *Applied and Environmental Microbiology*, 64(12): 4643–9.
- Rescott, D. L., Nix, D. E., Holden, P., and Schentag, J. J. (1988).** "Comparison of two methods for determining *in vitro* postantibiotic effects of three antibiotics on *Escherichia coli*." *Antimicrobial Agents and Chemotherapy*, 32(4): 450–453.
- Ribeiro, C., Marks, J., and Grimshaw, A. (1985).** "Economic cultivation of "thermophilic" *Campylobacter* spp." *Journal of Clinical Pathology*, 38(11): 1311–2.
- Richards, R. M., Xing, D. K., and King, T. P. (1993).** "Effects on cell morphology of growing *Pseudomonas aeruginosa*, *Enterobacter cloacae* and *Staphylococcus aureus* in subinhibitory concentrations of p-aminobenzoic acid." *Microbios*, 73(295): 105–111.
- Rizvi, S. S. H. (2005).** *Engineering properties of foods*, chapter 7, page 251. CRC Press Inc., Taylor & Francis Group, 3rd edition.
- Robinson, D. (1981).** "Infective dose of *Campylobacter jejuni* in milk." *British Medical Journal*, 282: 1584.



- Robinson, M. and Horn, J. (2003).** "Clinical pharmacology of proton pump inhibitor: what the practising physician needs to know." *Drugs*, 63(24): 2739–2754.
- Rockville, M. D. (1990a).** *United States Pharmacopeia: The National Formulary XXII*, chapter : United States pharmacopoeial convention: simulated gastric fluid, page 1788.
- Rockville, M. D. (1990b).** *United States Pharmacopeia: The National Formulary XXII*, chapter : United States pharmacopoeial convention: simulated intestinal fluid, page 1789.
- Roos, D. and Balm, A. J. M. (1980).** "The oxidative metabolism of monocytes." In A. J. Sbarra and R. R. Strauss, editors, "The Reticuloendothelial System. A Comprehensive Treatise. Volume 2. Biochemistry and Metabolism," pages 189–229. Plenum Press, New York.
- Rosenblatt, J. E. and Schoenknecht, F. (1972).** "Effect of several components of anaerobic incubation on antibiotic susceptibility test results." *Antimicrobial Agents and Chemotherapy*, 1(5): 433–440.
- Rosendale, D. I., Maddox, I. S., Miles, M. C., Rodier, M., Skinner, M., and Sutherland, J. (2008).** "High-throughput microbial bioassays to screen potential New Zealand functional food ingredients intended to manage the growth of probiotic and pathogenic gut bacteria." *International Journal of Food Science and Technology*, 43(12): 2257–2267.
- Roseveare, C. D., Van Heel, D. A., Arthur, M. J. P., and Lawrance, R. J. (1998).** "*Helicobacter pylori*: beware "blind" eradication!" *Gut*, 42(5): 757.
- Roth, L. A., Kwan, S., and Sporns, P. (1986).** "Use of a disc-assay system to detect oxytetracycline residues in honey." *Journal of Food Protection*, 49(6): 436–441.

- Roussos, A., Stambori, M., Aggelis, P., Kanavaki, S., Garzonis, P., Makarona, M., Kapralos, C., Karambela, S., Dalamaga, A., and Ferti, A. (2001).** "Transfusion-mediated *Yersinia enterocolitica* septicemia in an adult patient with beta-thalassemia." *Scandinavian Journal of Infectious Diseases*, 33(11): 859–860.
- Rowbury, R. J., Goodson, M., and Humphrey, T. J. (1993).** "Novel acid sensitivity induced in *Escherichia coli* at alkaline pH." *Letters in Applied Microbiology*, 16: 223–227.
- Rowbury, R. J. and Hussain, N. H. (1996).** "Exposure of *Escherichia coli* to acid habituation conditions sensitizes it to alkaline stress." *Letters in Applied Microbiology*, 22: 57–61.
- Rüegg, M. and Blanc, B. (1981).** "The water activity of honey and related sugar solutions." *Lebensmittel-Wissenschaft und -Technologie*, 14: 1–6.
- Russell, K. M., Molan, P. C., Wilkins, A. L., and Holland, P. T. (1990).** "Identification of some antibacterial constituents of New Zealand manuka honey." *Journal of Agricultural Food Chemistry*, 38: 10–13.
- Rybak, M. J., Hershberger, E., Moldovan, T., and Grucz, R. G. (2000).** "In vitro activities of daptomycin, vancomycin, linezolid, and quinupristin-dalfopristin against staphylococci and enterococci, including vancomycin-intermediate and -resistant strains." *Antimicrobial Agents and Chemotherapy*, 44: 1062–1066.
- Ryder, C., Byrd, M., and Wozniak, D. J. (2007).** "Role of polysaccharides in *Pseudomonas aeruginosa* biofilm development." *Current Opinion in Microbiology*, 10(6): 644–648.
- Saito, T., Senda, K., Takakura, S., Fujihara, N., Kudo, T., Iinuma, Y., Kiyuchi, T., Tanimoto, M., and Ichiyama, S. (2003).** "Biliary bacteria in living

- related liver transplant recipients: microbiology and rapid detection system using flow cytometry." *Clinical Chemistry and Laboratory Medicine*, 41(2): 159–163.
- Sakagami, Y., Mimura, M., Kajimura, K., Yokoyama, H., and Nishimura, H. (1999).** "Electron-microscopic study of the bactericidal effect of OPB-2045, a new mono-biguanide disinfectant produced from biguanide group compounds, against *Pseudomonas aeruginosa*." *The Journal of Pharmacy and Pharmacology*, 51(2): 201–206.
- Salem, S. N. (1981).** "Honey regimen in gastrointestinal disorders." *Bulletin of Islamic Medicine*, 1: 358–362.
- Sanyal, A. J., Shiffmann, M. L., Hirsch, J. I., and Moore, E. W. (1991).** "Premicellar taurocholate enhances ferrous iron uptake from all regions of rat small intestine." *Gastroenterology*, 101(2): 382–389.
- Sanz, M. L., Polemis, N., Morales, V., Corzo, N., Drakoularakou, A., Gibson, G. R., and Rastall, R. A. (2005).** "In vitro investigation into the potential prebiotic activity of honey oligosaccharides." *Journal of Agricultural and Food Chemistry*, 53: 2914–2921.
- Sasahara, K. and Zottola, E. (1993).** "Biofilm formation by *Listeria monocytogenes* utilizes a primary colonizing microorganism in flowing systems." *Journal of Food Protection*, 56: 1022–1028.
- Sawers, G. (1999).** "The aerobic/anaerobic interface." *Current Opinion in Microbiology*, 2: 181–187.
- Saxelin, M., Tynkkynen, S., Mattila-Sandholm, T., and de Vos, W. M. (2005).** "Probiotic and other functional microbes: from markets to mechanisms." *Current Opinion in Biotechnology*, 16: 204–211.

- Schepartz, A. I. and Subers, M. H. (1964).** "The glucose-oxidase of honey. I. Purification and some general properties of the enzyme." *Biochimica et Biophysica Acta*, 85: 228–237.
- Schmidt, G. and Zink, R. (2000).** "Basic features of the stress response in three species of bifidobacteria: *B. longum*, *B. adolescentis*, and *B. breve*." *International Journal of Food Microbiology*, 55(1-3): 41–45.
- Scott, W. J. (1957).** "Water relations of food spoilage microorganisms." *Advances in Food Research*, 7: 83–127. Antiseptics and Antimicrobial Agents p120.
- Servin, A. L. (2004).** "Antagonistic activities of lactobacilli and bifidobacteria against microbial pathogens." *FEMS Microbiology Reviews*, 28(4): 405–440.
- Shamala, T., Shri Jyothi, Y., and Saibaba, P. (2000).** "Stimulatory effect of honey on multiplication of lactic acid bacteria under *in vitro* and *in vivo* conditions." *Letters in Applied Microbiology*, 30(6): 453–5.
- Shannon, I., Edmonds, E., and Madsen, K. (1979).** "Honey: sugar content and cariogenicity." *ASDC Journal of Dentistry for Children*, 46(1): 29–33.
- Sharma, R., Sharma, C. L., and Kapoor, B. (2005).** "Antibacterial resistance: current problems and possible solutions." *Indian Journal of Medical Sciences*, 59(3): 120–129.
- Shin, H.-S. and Ustunol, Z. (2005).** "Carbohydrate composition of honey from different floral sources and their influence on growth of selected intestinal bacteria: An *in vitro* comparison." *Food Research International*, 38(6): 721–8.
- Silley, P. (2003).** "Campylobacter and fluoroquinolones: a bias data set?" *Environmental Microbiology*, 5(4): 219–30.

- Sjölund, M., Wreiber, K., Andersson, D. I., Blaser, M. J., and Engstrand, L. (2003).** "Long-term persistence of resistant *Enterococcus* species after antibiotics to eradicate *Helicobacter pylori*." *Annals of Internal Medicine*, 139: 483–487.
- Slots, J. (1982).** "Selective medium for isolation of *Actinobacillus actinomycescomitans*." *Journal of Clinical Microbiology*, 15(4): 606–609.
- Smith, A. (2005).** "Outbreak of *Clostridium difficile* infection in an English hospital linked to hyper toxin-producing strains in Canada and the US." *Eurosurveillance*, 10: 050630. URL <http://www.eurosurveillance.org/ew/2005/050630asp#2> [accessed: 6/May/2009].
- Smith, J. (2002).** "*Campylobacter jejuni* infection during pregnancy: long-term consequences of associated bacteremia, Guillain-Barré syndrome, and reactive arthritis." *Journal of Food Protection*, 65(4): 696–708.
- Sneath, P. H. A. and Holt, J. G. (1986).** *Bergey's Manual of Systematic Bacteriology. Volume 2*, volume 2. Williams & Wilkins, Baltimore, U.S.A.
- Snow, M. and Manley-Harris, M. (2004).** "On the nature of non-peroxide antibacterial activity in New Zealand manuka honey." *Food Chemistry*, 84(1): 145–7.
- Snowdon, J. A. and Cliver, D. O. (1996).** "Microorganisms in honey." *International Journal of Food Microbiology*, 31(1-3): 1–26.
- Söderlin, M. K., Alasaarela, E., and Hakala, M. (1999).** "Reactive arthritis induced by *Clostridium difficile* enteritis as a complication of *Helicobacter pylori* eradication." *Clinical Rheumatology*, 18(4): 337–338.
- Stanley, T. and Moore, J. E. (2000).** "Long-term preservation of thermophilic *Campylobacter* species: a simple method." *British Journal of Biomedical Science*, 57(3): 214–5.

- Stecher, P. G., Windholz, M., Leahy, D. S., Bolton, D. M., and Eaton, L. G.,** editors (1968). *The Merck Index*. MERCK & Co., Inc.; Rahway, New Jersey, U.S.A., 8th edition.
- Stephens, J. M. C. (2006).** *The factors responsible for the varying levels of UMF in manuka (Leptospermum scoparium) honey*. Ph.D. thesis, The University of Waikato. Available from the Australasian Digital Theses Program, <http://adt.waikato.ac.nz/public/adt-uow20060718.123239/>.
- Stubbings, W. J., Bostock, J. M., Ingham, E., and Chopra, I. (2004).** "Assessment of a microplate method for determining the post-antibiotic effect in *Staphylococcus aureus* and *Escherichia coli*." *The Journal of Antimicrobial Chemotherapy*, 54(1): 139–143.
- Stubbings, W. J., Bostock, J. M., Ingham, E., and Chopra, I. (2006).** "Mechanisms of the post-antibiotic effects induced by rifampicin and gentamicin in *Escherichia coli*." *The Journal of Antimicrobial Chemotherapy*, 58(2): 444–8.
- Suller, M. T. E. and Lloyd, D. (2002).** "The antibacterial activity of vancomycin towards *Staphylococcus aureus* under aerobic and anaerobic conditions." *Journal of Applied Microbiology*, 92: 866–872.
- Sullivan, Å., Edlund, C., and Nord, C. E. (2001).** "Effect of antimicrobial agents on the ecological balance of human microflora." *The Lancet Infectious Diseases*, 1: 101–114.
- Sullivan, A. and Nord, C. (2005).** "Probiotics and gastrointestinal diseases." *Journal of Internal Medicine*, 257(1): 78–92.
- Sullivan, Å. and Nord, C. E. (2002).** "Probiotics in human infections." *Journal of Antimicrobial Chemotherapy*, 50: 625–627.
- Surawicz, C. (2003).** "Probiotics, antibiotic-associated diarrhoea and *Clostridium difficile* diarrhoea in humans." *Best Practice & Research. Clinical Gastroenterology*, 17: 775–83.

- Tachon, M., Cattoen, C., Blanckaert, K., Poujol, I., Carbonne, A., Barbut, F., Petit, J. C., and Coignard, B. (2006).** "First cluster of *C. difficile* toxin III, PCR-ribotype O27 associated disease in France: preliminary report." *Eurosurveillance*, 11: E060 504.1. URL <http://www.eurosurveillance.org/ew/2006/060504.asp#1> [accessed: 6/May/2009].
- Takayama, S., Satake, S., and Ishihara, K. (2005).** "Antimicrobial susceptibility of *Campylobacter jejuni* and *Campylobacter coli* isolated from human diarrheic samples." *Kansenshogaku Zasshi*, 79(3): 169–175.
- Tamplin, M. L. (2005).** "Inactivation of *Escherichia coli* O157:H7 in simulated human gastric fluid." *Applied and Environmental Microbiology*, 71(1): 320–5.
- Taormina, P. J., Niemira, B. A., and Beuchat, L. R. (2001).** "Inhibitory activity of honey against foodborne pathogens as influenced by the presence of hydrogen peroxide and level of antioxidant power." *International Journal of Food Microbiology*, 69(3): 217–25.
- Teare, J. P., Booth, J. C., Brown, J. L., Martin, J., and Thomas, H. C. (1995).** "Pseudomembranous colitis following clarithromycin therapy." *European Journal of Gastroenterology & Hepatology*, 7(3): 275–277.
- Thakur, S. and Gebreyes, W. A. (2005).** "*Campylobacter coli* in swine production: antimicrobial resistance mechanisms and molecular epidemiology." *Journal of Clinical Microbiology*, 43(11): 5705–5714.
- Thimann, K. V. (1963).** *The Life of Bacteria*. Macmillan, New York, 2nd edition.
- Thornalley, P. J. (2003).** "Glyoxalase I – structure, function and a critical role in the enzymatic defence against glycation." *Biochemical Society Transactions*, 31(Pt 6): 1343–1348.

- Thornsberry, C. and Kirven, L. A. (1974).** "Antimicrobial susceptibility of *Haemophilus influenzae*." *Antimicrobial Agents and Chemotherapy*, 6(5): 620–624.
- Tipple, M. A., Bland, L. A., Murphy, J. J., Arduino, M. J., Panlilio, A. L., III, F. J. J., Tourault, M. A., Macpherson, C. R., Menitove, J. E., and Grindon, A. J. (1990).** "Sepsis associated with transfusion of red cells contaminated with *Yersinia enterocolitica*." *Transfusion*, 30(3): 207–13.
- Tompkins, D., Dave, J., and Mapstone, N. (1994).** "Adaptation of *Helicobacter pylori* to aerobic growth." *European Journal of Clinical Microbiology & Infectious Diseases*, 13(5): 409–12.
- Turner, F. J. (1983).** *Hydrogen Peroxide and Other Oxidant Disinfectants*. Disinfection, Sterilization and Preservation. Lea and Febiger, Philadelphia, 3rd edition.
- Tysset, C., Rousseau, M., and Durand, C. (1980).** "Microbism and wholesomeness of commercial honey." *Apiacta*, 15(2): 51–60.
- Udekwu, K. I., Parrish, N., Ankomah, P., Baquero, F., and Levin, B. R. (2009).** "Functional relationship between bacterial cell density and the efficacy of antibiotics." *Journal of Antimicrobial Chemotherapy*, 63: 745–757.
- Ustunol, Z. and Gandhi, H. (2001).** "Growth and viability of commercial *Bifidobacterium* spp. in honey-sweetened skim milk." *Journal of Food Protection*, 64(11): 1775–9.
- Valdezate, S., Arroyo, M., González-Sanz, R., Ramiro, R., Herrera-León, S., Usera, M. A., De la Fuente, M., and Echeita, A. (2007).** "Antimicrobial resistance and phage and molecular typing of *Salmonella* strains isolated from food for human consumption in Spain." *Journal of Food Protection*, 70(12): 2741–2748.



- van Boven, M., Veldman, K. T., de Jong, M. C., and Mevius, D. J. (2003). "Rapid selection of quinolone resistance in *Campylobacter jejuni* but not in *Escherichia coli* in individually housed broilers." *The Journal of Antimicrobial Chemotherapy*, 52(4): 719–23.
- van Steenberghe, J., Debast, S., van Kregten, E., van den Berg, R., Notermans, D., and Kuijper, E. J. (2005). "Isolation of *Clostridium difficile* ribotype O27, toxin III in the Netherlands after increase in *C. difficile*-associated diarrhoea." *Eurosurveillance Weekly*, 10: E050714.1. URL <http://www.eurosurveillance.org/ew/2005/050714.asp#1>[accessed:6/May/2009].
- van Velkinburgh, J. C. and Gunn, J. S. (1999). "PhoP-PhoQ-regulated loci are required for enhanced bile resistance in *Salmonella* spp." *Infection and Immunity*, 67(4): 1614–1622.
- Vander Jagt, D. L. (1993). "Glyoxalase II: molecular characteristics, kinetics and mechanism." *Biochemical Society Transactions*, 21(2): 522–527.
- Varga, L. (2006). "Effect of acacia (*Robinia pseudo-acacia* L.) honey on the characteristic microflora of yogurt during refrigerated storage." *International Journal of Food Microbiology*, 108(2): 272–5.
- Versalovic, J. and Fox, J. G. (2003). "Helicobacter." In P. R. Murray, E. J. Baron, J. H. Jorgensen, M. A. Pfaller, and R. H. Tenover, editors, "Manual of Clinical Microbiology," volume 1, pages 915–28. ASM Press, Washington, D.C., 8th edition.
- Voravuthikunchai, S. P., Bilasoi, S., and Supamala, O. (2006). "Antagonistic activity against pathogenic bacteria by human vaginal lactobacilli." *Anaerobe*, 12(5-6): 221–226.
- Voth, D. E. and Ballard, J. D. (2005). "*Clostridium difficile* toxins: mechanism of action and role in disease." *Clinical Microbiology Reviews*, 18(2): 247–263.

- Waites, W. M., Bayliss, C. E., King, N. R., and Davies, A. M. C. (1979). "The effect of transitional metal ions on the resistance of bacterial spores to hydrogen peroxide and to heat." *Journal of General Microbiology*, 112: 225–233.
- Wallis, M. (1994). "The pathogenesis of *Campylobacter jejuni*." *British Journal of Biomedical Science*, 51(1): 57–64.
- Wang, G., Clark, C. G., Taylor, T. M., Pucknell, C., Barton, C., Price, L., Woodward, D. L., and Rodgers, F. G. (2002). "Colony multiplex PCR assay for identification and differentiation of *Campylobacter jejuni*, *C. coli*, *C. lari*, *C. upsaliensis*, and *C. fetus* subsp. *fetus*." *Journal of Clinical Microbiology*, 40(12): 4744–7.
- Wang, W.-L. L. and Luechtefeld, N. W. (1983). "Effect of incubation atmosphere and temperature on isolation of *Campylobacter jejuni* from human stools." *Canadian Journal of Microbiology*, 29(4): 468–70.
- Wang, W.-L. L., Luechtefeld, N. W., Blaser, M. J., and Reller, L. B. (1982). "Comparison of CampyPak II with standard 5% oxygen and candle jars for growth of *Campylobacter jejuni* from human feces." *Journal of Clinical Microbiology*, 16(2): 291–4.
- Warren, J. R. and Marshall, B. (1983). "Unidentified curved bacilli on gastric epithelium in active chronic gastritis." *The Lancet*, 321(8336): 1273–1275.
- Wasył, D., Sandvang, D., Skov, M. N., and Baggesen, D. L. (2006). "Epidemiological characteristics of *Salmonella* Typhimurium isolated from animals and feed in Poland." *Epidemiology and Infection*, 134(1): 179–185.
- Waterman, S. R. and Small, P. (1998). "Acid-sensitive enteric pathogens are protected from killing under extremely acidic conditions of pH 2.5 when they are inoculated onto certain solid food sources." *Applied and Environmental Microbiology*, 64(10): 3882–3886.

- Weill, F. X., Guesnier, F., Guibert, V., Timinouni, M., Demartin, M., Polomack, L., and Grimont, P. A. (2006). "Multidrug resistance in *Salmonella enterica* serotype Typhimurium from humans in France (1993 to 2003)." *Journal of Clinical Microbiology*, 44(3): 700–708.
- Weiss, S. J., Peppin, G., Ortiz, X., Ragsdale, C., and Test, S. T. (1985). "Oxidative autoactivation of latent collagenase by human neutrophils." *Science*, 227: 747–749.
- Weyant, R. S., Hollis, D. G., Weaver, R. E., Amin, M. F., Steigerwalt, A. G., O'Connor, S. P., Whitney, A. M., Daneshvar, M. I., Moss, C. W., and Brenner, D. J. (1995). "*Bordetella holmesii* sp. nov., a new gram-negative species associated with septicemia." *Journal of Clinical Microbiology*, 33(1): 1–7.
- White, J. W. (1975). "Composition of Honey." In E. Crane, editor, "Honey: a Comprehensive Survey," chapter 5, pages 157–206. Heinemann, London.
- White, J. W., Kushnir, I., and Subers, M. H. (1964). "Effect of storage and processing temperatures on honey quality." *Food Technology*, 18(4): 153–6.
- White, R., Cooper, R., and Molan, P. (2006). *Honey: a Modern Wound Management Product*. Wounds UK, Aberdeen.
- Wiegand, I. and Burak, S. (2004). "Effect of inoculum density on susceptibility of *Plesiomonas shigelloides* to cephalosporins." *Journal of Antimicrobial Chemotherapy*, 54: 418–423.
- Wilson, M. (2008). *Bacteriology of Humans: An Ecological Perspective*. Blackwell Publishing.
- Witte, W. (2000). "Ecological impact of antibiotic use in animals on different complex microflora: environment." *International Journal of Antimicrobial Agents*, 14(4): 321–325.

- World Health Organisation (1976).** "Treatment and Prevention of Dehydration in Diarrhoeal Diseases." Technical Report ISBN 92 4 154052 4, World Health Organisation.
- World Health Organisation (2006).** *Oral rehydration salts: production of the new ORS.*
- World Health Organization and International Agency for Research on Cancer (1994).** "Schistosomes, liver flukes and *Helicobacter pylori*." URL <http://www.iarc.fr>[accessed:6/May/2009].
- Yamamoto, N. and Droffner, M. L. (1985).** "Mechanisms determining aerobic or anaerobic growth in the facultative anaerobe *Salmonella typhimurium*." *Proceedings of the National Academy of Sciences of the United States of America*, 82: 2077–2081.
- Youssef, S. S., Iskandar, S. B., Scruggs, J., and Roy, T. M. (2005).** "Acute pancreatitis associated with omeprazole." *International Journal of Clinical Pharmacology and Therapeutics*, 43(12): 558–561.
- Yuk, H.-G. and Marshall, D. L. (2004).** "Adaptation of *Escherichia coli* O157:H7 to pH alters membrane lipid composition, verotoxin secretion, and resistance to simulated gastric fluid acid." *Applied and Environmental Microbiology*, 70(6): 3500–5.
- Zein, E. F., Karaa, S., Chemaly, A., Saidi, I., Daou-Chahine, W., and Rohban, R. (2008).** "*Lactobacillus rhamnosus* septicemia in a diabetic patient associated with probiotic use: a case report." *Annales de Biologie Clinique*, 66(2): 195–198.

## APPENDIX

---

Lin, S.M. Molan, P.C. and Cursons, R.T. (2009). The *in vitro* susceptibility of *Campylobacter* spp. to the antibacterial effect of manuka honey. 28(4):339–344.

## The in vitro susceptibility of *Campylobacter* spp. to the antibacterial effect of manuka honey

S. M. Lin · P. C. Molan · R. T. Cursons

Received: 5 May 2008 / Accepted: 10 September 2008 / Published online: 26 September 2008  
© Springer-Verlag 2008

**Abstract** We report the antimicrobial effect of manuka honey against *Campylobacter* spp. isolated by a diagnostic laboratory from specimens from a community in New Zealand. The isolates were differentiated according to species level using multiplex PCR. *C. jejuni* (20 strains) and *C. coli* (7 strains) were identified. The clinical isolates identified and type culture collection strains of these species were subjected to testing to determine the minimum inhibitory concentration (MIC) of manuka honey using a microdilution technique. The MIC of the manuka honey against all of the *Campylobacter* tested was found to be around 1% (v/v) honey. The low MIC values suggest that honey might still inhibit the growth of campylobacteria after dilution by fluid in the gut, but the actual concentration of honey that can be achieved in the intestine is unknown. Therefore, clinical investigation is required to establish the efficacy of honey against *Campylobacter* spp. in the gut environment.

### Introduction

*Campylobacter* spp. is a widespread zoonotic pathogen and has been recognised as a leading cause of gastroenteritis worldwide. The prevalence of campylobacteriosis has been reported to outnumber that of enteritis caused by other

common food-borne pathogens such as *Salmonella* spp. or *Escherichia coli* in several developed and developing countries [1, 2]. New Zealand has the highest prevalence of campylobacteriosis in the developed world [3].

*Campylobacter* spp. is fastidious in respect of nutrition and atmosphere; therefore, strict growth conditions are required for survival, although *Campylobacter* spp. have an extremely low infectious dose of 500 cells [4, 5]. Mostly, campylobacteriosis is self-limited, and it can be treated with antibiotics such as fluoroquinolones. However, deaths have been reported occasionally [6, 7] and its linkage to Guillain-Barré syndrome [8] and abortion [9] is also of great concern. Furthermore, although not reported yet in New Zealand, antibiotic-resistant strains have been reported in developed and developing countries [10–12]. The increasing rate of resistance to antibiotics is thought to be due to the over-use of antibiotics in veterinary treatment [13].

A clinical trial has been conducted in which it was found that administration of honey halved the duration of bacterial diarrhoea [14] and although in that clinical report the function of re-hydration was emphasised, the easing of the symptoms may also have been due to the antibacterial activity of honey, since honey shortened the duration of bacterial diarrhoea, but not that of viral diarrhoea. Honey has been used as a treatment for wound infections since ancient times [15], and has been found to inhibit the growth of a wide range of bacterial species in vitro [16]. However, there have been very few studies testing the efficacy of honey against the widespread *Campylobacter* spp. Although Adebolu reported the effect of two types of African honey on diarrhoea-causing bacteria, including one strain of *C. jejuni* [17], there were several shortcomings in that report that may cast doubt upon the reliability of the results published. From that report it is not known whether or not other strains or species of *Campylobacter* had the same

S. M. Lin (✉) · P. C. Molan  
Honey Research Unit, Department of Biological Sciences,  
University of Waikato,  
Hamilton, New Zealand  
e-mail: semin2006@gmail.com

R. T. Cursons  
Molecular Genetics Laboratory,  
Department of Biological Sciences, University of Waikato,  
Hamilton, New Zealand

sensitivity to honey. Also in that report, Adebolu used the agar diffusion method with nutrient media [17], which may not be suitable for testing the sensitivity of slow-growing bacteria like *Campylobacter* spp. against honey, as the honey may have diffused out into the agar to a level below the MIC by the time the organism had grown. But most importantly, in that paper tests were carried out with types of honey whose antimicrobial potency had not yet been determined; yet, the potency of antibacterial activity in honey may in fact vary up to 100-fold [18], and the reported sensitivity of the strain of *C. jejuni* to Adebolu's honey could have been one hundred times higher or lower than the sensitivity to any other randomly chosen honey on the market.

A few types of honey, such as manuka honey from *Leptospermum scoparium* in New Zealand, are reported to have particularly high antimicrobial activity against various bacterial species [19]. Manuka honey is coming into widespread usage for the treatment of infected wounds [20]. Therefore, the objectives of this study were to investigate the antibacterial activity of manuka honey against a number of clinical isolates of *Campylobacter* spp. from clinical patients with diarrhoea using the broth dilution method. The manuka honey we used had its antimicrobial activity standardised against a reference antiseptic, phenol. To distinguish the effect of the antibacterial component of honey from any osmotic effects, artificial honey, which was syrup simulating the sugar composition of honey, was also used for comparison.

## Materials and methods

### Honey samples

The manuka honey used in this work had the strength of its antibacterial activity assayed by the method described by Allen et al. with catalase added [19]. This is an agar well diffusion assay that compares the activity of honey with that of a standard antiseptic phenol. The manuka honey used had activity equivalent to that of 29.4% phenol when tested against *Staphylococcus aureus* ATCC 25923. Artificial honey was made up, containing 30.5% glucose, 37.5% fructose and 1.5% sucrose, and was dissolved in distilled water [21]. The two types of honey were stored in the dark at 4°C until used.

### Microbiological materials

*Campylobacter* spp. is widely known as a fastidious pathogen and requires strict control of growth conditions. The National Committee for Clinical Laboratory Standards (NCCLS) has suggested an outline for investigating the

susceptibility of *Campylobacter* to antibiotics [22]; nonetheless, a “gold standard” protocol for studying this genus does still not exist [23]. For instance, the agar dilution method using Mueller–Hinton agar supplemented with 5% defibrinated sheep blood is recommended in the outline where the blood is added to the medium to protect *Campylobacter* spp. from damage by oxygen-derived components such as free radicals and hydrogen peroxide [24, 25]. However, it is not applicable in this study because the antibacterial activity of manuka honey may be partially due to hydrogen peroxide [16, 26], which would be inactivated by catalase present in blood. Instead, freshly made Mueller–Hinton broth was used in the susceptibility test. Blood-free *Campylobacter* selective agar (Oxoid) containing amphotericin and cefoperazone (LAB M) as selective agents was used to culture the isolates. Brain heart infusion yeast extract broth (BHIYE, with 0.6% yeast extract) supplemented with FBP (0.025% ferrous sulfate, 0.025% sodium metabisulfite and 0.025% sodium pyruvate) [27, 28] was used for enrichment, and that containing 15% sterile glycerol was used as a cryopreservative agent.

### *Campylobacter* samples

*Campylobacter* clinical isolates were kindly provided by Chris Picket (Medlab, Hamilton, New Zealand) and were stored in fastidious anaerobe transport swabs (Copan Italia, Brescia, Italy) when transporting them from Medlab to the Honey Research Unit. The isolates were then streaked on selective agar plates and cultured at 37°C in a micro-aerobic atmosphere generated with the spirits burn method [29] for 2 days. The cultures recovered were enriched in BHIYE-FBP and incubated overnight micro-aerobically as above, then dispensed into small vials containing cryopreservative agent and stored at –70°C. Type culture collection strains *C. jejuni* (ATCC 33560) and *C. coli* (ATCC 33559) were also processed in this way as growth controls.

As Medlab only differentiates the isolates to genus level, extra differentiation work to species level was needed for investigating the effect of manuka honey on different species of *Campylobacter*. In this research the multiplex polymerase chain reaction was used to do this [30].

### *Campylobacter* DNA extraction

*Campylobacter* DNA was extracted by boiling. A loopful of colony for each isolate was taken from its culture plates, resuspended in 100 µl of distilled water, heated in a boiling water bath for 10 min and chilled on ice for another 10 min, followed by the addition of 100 µl of chloroform and brief centrifuging. The supernatant was stored at –20°C until the PCR test was carried out.

### Multiplex PCR

Each PCR mix (20  $\mu$ l) consisted of 6  $\mu$ l of DNA templates, 2.4  $\mu$ l of 20  $\mu$ mol/l primers mix (Sigma), 8  $\mu$ l of HotMasterMix ( $\times 2.5$ ; Eppendorf) and 3.6  $\mu$ l of MilliQ water. The primers used in this work are shown in Table 1.

The DNA amplification procedure was carried out in a PTC-100 thermocycler (MJ Research, Waltham, MA, USA). The cycling conditions used were 94°C for 2 min as initial denaturation, followed by 30 cycles of amplification (denaturation at 95°C for 30 s, annealing at 59°C for 20 s, extension at 68°C for 40 s) and 68°C for 6 min for the final extension. The amplified products were electrophoresed in 1.5% agarose gel and analysed using the ScionImage system.

### Susceptibility test

#### Inoculum preparation

Each isolate was recovered by rubbing the surface of the frozen culture with a sterilised cotton swab, then streaking onto blood-free *Campylobacter* selective agar and incubating micro-aerobically for 48 h at 37°C. The colonies recovered were collected with a cotton swab and suspended in Mueller–Hinton broth. The optical density at 625 nm was adjusted to 0.08 with fresh broth and was then further diluted 500-fold. This gave a final culture density of approximately  $10^5$  cfu/ml after inoculating the honey solution in the microplate wells. The inoculum density was confirmed using the track dilution method [31].

#### Susceptibility test

A 10% (v/v) solution of manuka honey and 20% (v/v) artificial honey were prepared with Mueller–Hinton broth and filter-sterilised with a 0.2- $\mu$ m filter (Sartorius) before serial dilution. As the MIC of artificial honey would presumably be higher than that of manuka honey, 20% (v/v) solution of artificial honey was used in this test.

Of the 12 columns in a microplate, the first column was added with 40  $\mu$ l of manuka honey, the second to the tenth with 40  $\mu$ l of Mueller–Hinton broth and the last two with a growth control (*Campylobacter* spp. and Mueller–Hinton broth added) and sterility check (plain Mueller–Hinton

broth). For serial dilution 160  $\mu$ l of honey was added into the second column, which was then sequentially transferred to the following wells up to the tenth well. After that, 80  $\mu$ l of inoculum was added into each well except the last well, in which 80  $\mu$ l of plain Mueller–Hinton broth was added instead so that the final concentrations of the honey were 3.33%, 2.66%, 2.13%, 1.70%, 1.36%, 1.09%, 0.87%, 0.7%, 0.56% and 0.45% after inoculation. The final concentrations of artificial honey would be twice of those of manuka honey.

The plate was incubated micro-aerobically at 37°C for 48 h. The lowest concentration of honey needed to completely inhibit the growth of the isolate was considered to be its MIC. After this, from each well, 1  $\mu$ l was subcultured onto blood-free *Campylobacter*-selective agar to see if the honey was bacteriostatic or bacteriocidal to *Campylobacter* spp. The cultures in the growth control wells were also subcultured as positive controls. The susceptibility test for each species was replicated up to five times. The difference between the two types of honey in the results was analysed using the Wilcoxon test in the statistical package R (<http://www.r-project.org>) [32].

## Results

### Multiplex PCR identification

According to the multiplex PCR, of the 27 clinical isolates collected from Medlab, 20 were identified as *C. jejuni* and the rest as *C. coli*.

### Susceptibility test

The susceptibility test revealed that the growth of all 29 species was largely inhibited by both manuka honey and artificial honey (Table 2). For both *C. jejuni* and *C. coli*, the MIC of manuka honey was significantly lower than that of artificial honey ( $P < 0.01$ ). The MIC of manuka honey ranged from 0.8% to 1.1%, whereas that of artificial honey was 3–4 times higher than that of manuka honey (3.1–4.3%).

The subculturing after determining the MIC showed that growth occurred when subculturing from concentrations of honey below the MIC, whereas there was no growth from

**Table 1** Oligonucleotide primers and their amplicon sizes used in this study [30]

Species	Target gene	Sequence (5'-3')	GeneBank accession no.	Amplicon size (bp)
<i>C. jejuni</i>	<i>C. jejuni</i> hipO	Forward: ACTTCTTTATGCTTGCTGC Reverse: GCCACAACAAGTAAAGAAGC	Z36940	323
<i>C. coli</i>	<i>C. coli</i> glyA	Forward: GTAAAACCAAAGCTTATCGTG Reverse: TCCAGCAATGTGTGCAATG	AF136494	126



**Table 2** Minimum inhibitory concentration (percentage v/v) of manuka honey and artificial honey for each strain

Strains	Manuka honey	Artificial honey
<i>C. jejuni</i> 1	0.84±0.08	3.13±0.39
<i>C. jejuni</i> 2	1±0.12	3.58±0.38
<i>C. jejuni</i> 3	1±0.12	3.44±0.55
<i>C. jejuni</i> 4	0.8±0.09	3.13±0.39
<i>C. jejuni</i> 5	0.88±0.14	3.58±0.38
<i>C. jejuni</i> 6	1.05±0.1	3.27±0.32
<i>C. jejuni</i> 7	0.92±0.17	3.75±0.47
<i>C. jejuni</i> 8	0.96±0.12	3.75±0.47
<i>C. jejuni</i> 9	1±0.12	3.92±0.47
<i>C. jejuni</i> 10	0.8±0.09	3.58±0.38
<i>C. jejuni</i> 11	0.91±0.1	3.58±0.38
<i>C. jejuni</i> 12	1.05±0.1	3.92±0.47
<i>C. jejuni</i> 13	0.96±0.12	3.92±0.47
<i>C. jejuni</i> 14	0.88±0.14	3.61±0.66
<i>C. jejuni</i> 15	0.96±0.12	3.75±0.47
<i>C. jejuni</i> 16	1.05±0.1	3.75±0.47
<i>C. jejuni</i> 17	0.8±0.09	3.92±0.47
<i>C. jejuni</i> 18	1±0.12	3.92±0.47
<i>C. jejuni</i> 19	0.96±0.12	3.58±0.38
<i>C. jejuni</i> 20	0.92±0.17	3.61±0.66
<i>C. jejuni</i> ATCC 33560	1±0.12	3.58±0.38
<i>C. coli</i> 1	1.05±0.1	4.09±0.38
<i>C. coli</i> 2	1±0.12	4.3±0.68
<i>C. coli</i> 3	1.14±0.12	4.09±0.38
<i>C. coli</i> 4	1.1±0.17	3.92±0.47
<i>C. coli</i> 5	1.2±0.15	3.92±0.47
<i>C. coli</i> 6	1.14±0.12	4.09±0.38
<i>C. coli</i> 7	1.1±0.17	3.92±0.47
<i>C. coli</i> ATCC 33559	1.05±0.1	4.09±0.38
Mean of <i>C. jejuni</i> (n=21)	0.94±0.08	3.63±0.24
Mean of <i>C. coli</i> (n=8)	1.1±0.06	4.05±0.13

The values are represented as means of the replicates ± standard deviation. The numbers of the replicates are given in parentheses. The determination of the MIC values for each isolate was replicated five times

concentrations at and above the MIC. This revealed that the MIC of either manuka honey or artificial honey was also the minimum bacteriocidal concentration for all of the *Campylobacter* isolates in this study.

## Discussion

Although the manuka honey used in the present study had a level of activity twice as high as that of the manuka honey used in other studies published, overall, the average concentration of manuka honey required to inhibit the growth of all the *Campylobacter* spp. tested was still far lower than that required to inhibit most other microorganisms with manuka honey [33–38]. Although the data

obtained from this study cannot fully represent the profile of the genus *Campylobacter*, our results establish that the species tested are susceptible to both the antibacterial components and the osmolarity of manuka honey. Manuka honey has been reported to be highly effective against various pathogens, including methicillin-resistant *Staphylococcus aureus* (MRSA) and vancomycin-resistant enterococci (VRE) [34], and its low pH, low water activity, slowly released hydrogen peroxide and phytochemical antimicrobial components are collectively thought to be responsible for its high efficacy against bacteria [26]. The result in this work revealed that the efficacy is also observable on *Campylobacter*, regardless of strain.

In this study we also observed that even a low concentration sugar solution was effective against the isolates, which may suggest that *Campylobacter* spp. would be highly susceptible to osmolarity. Doyle [39] reported that *C. jejuni* could grow in brucella broth containing 1.5% of NaCl, but failed in 2.0% NaCl or greater, and although a large amount of *C. jejuni* ( $10^5$ – $10^6$  cfu/ml) may increase the tolerance in 6.5% salt at 4°C, the viable cells significantly decreased in 4.5% salt at room temperature. In that report Doyle showed that nalidixic acid-resistant thermophilic *Campylobacter* (NARTC) was generally tolerant to salt concentration; yet, it was still unable to grow in the presence of 2.5% NaCl. Doyle also noted that a few strains would adapt to up to 6.5% NaCl after frequent subculturing and claimed that osmolarity might not be ideal for inhibiting the growth of *Campylobacter* spp., but this increasing tolerance against osmotic solution was not observed in our studies. Interestingly, Reezal et al. [40] noted that the osmotic effect on *Campylobacter* was seen regardless of whether the osmolyte in the medium was glucose or salts. Accordingly, the high susceptibility of *Campylobacter* spp. to honey solutions observed in this study may be due in part to the osmotic effect of the sugar content as well as to other antimicrobial factors.

The high susceptibility of *Campylobacter* spp. to osmolarity, however, may not be of practical consequence from an antimicrobial viewpoint. The concentration of sugar in the gut would decline rapidly down below the effective dosage through absorption and may not inhibit the growth of *Campylobacter* spp. in the gut. Sugar is usually used for oral rehydration therapy or as immediate treatment for hypoglycaemia due to its rapid absorption through intestinal villi [41]. Therefore, dietary sugar is unlikely to contribute to the inhibition of campylobacteriosis. At this stage it is not known whether the phytochemical antibacterial component of manuka honey [42, 43] would be absorbed in a short time or would remain in the gut to inhibit bacterial growth after honey has been ingested. It

would be of interest to investigate in the future whether or not this component is absorbed in the gut.

In short, of the *Campylobacter* spp. isolates most were identified as *C. jejuni* and *C. coli*, and these were found to be sensitive to the types of honey used in this work. An unspecified type of honey with unknown antibacterial potency [14] has been reported to ease the symptoms of bacterial diarrhoea, and the findings in the present study on the susceptibility of *Campylobacter* spp. to manuka honey also suggest that honey might be useful for treating bacterial diarrhoea.

**Acknowledgements** We thank Chris Pickett and the staff of Medlab, Hamilton, New Zealand, for advice and for the provision of the campylobacteria cultures.

## References

- Allos BM (2001) *Campylobacter jejuni* infections: update on emerging issues and trends. Clin Infect Dis 32(8):1201–1206 doi:10.1086/319760
- Meldrum RJ, Smith RM, Wilson IG (2006) Three-year surveillance program examining the prevalence of *Campylobacter* and *Salmonella* in whole retail raw chicken. J Food Prot 69(4):928–931
- Institute of Environmental Science and Research (2006) Notifiable and other diseases in New Zealand—annual report 2005. Population and Environmental Health Group, Institute of Environmental Science and Research, pp 1–56
- Robinson DA (1981) Infective dose of *Campylobacter jejuni* in milk. Br Med J (Clin Res Ed) 282:1584
- Wallis MR (1994) The pathogenesis of *Campylobacter jejuni*. Br J Biomed Sci 51(1):57–64
- Meyer A, Stallmach T, Goldenberger D, Altwegg M (1997) Lethal maternal sepsis caused by *Campylobacter jejuni*: pathogen preserved in placenta and identified by molecular methods. Mod Pathol 10(12):1253–1256
- Peetermans WE, De Man F, Moerman P, van de Werf F (2000) Fatal prosthetic valve endocarditis due to *Campylobacter fetus*. J Infect 41(2):180–182 doi:10.1053/jinf.2000.0699
- Ang CW, Jacobs BC, Laman JD (2004) The Guillain-Barré syndrome: a true case of molecular mimicry. Trends Immunol 25(2):61–66 doi:10.1016/j.it.2003.12.004
- Smith JL (2002) *Campylobacter jejuni* infection during pregnancy: long-term consequences of associated bacteremia, Guillain-Barré syndrome, and reactive arthritis. J Food Prot 65(4):696–708
- Delsol AA, Sunderland J, Woodward MJ, Pumbwe L, Piddock LJV, Roe JM (2004) Emergence of fluoroquinolone resistance in the native *Campylobacter coli* population of pigs exposed to enrofloxacin. J Antimicrob Chemother 53:872–874 doi:10.1093/jac/dkh150
- Padungton P, Kaneene JB (2003) *Campylobacter* spp in human, chickens, pigs and their antimicrobial resistance. J Vet Med Sci 65(2):161–170 doi:10.1292/jvms.65.161
- Takayama S, Satake S, Ishihara K (2005) Antimicrobial susceptibility of *Campylobacter jejuni* and *Campylobacter coli* isolated from human diarrheic samples. Kansenshogaku Zasshi 79(3):169–175
- van Boven M, Veldman KT, de Jong MCM, Mevius DJ (2003) Rapid selection of quinolone resistance in *Campylobacter jejuni* but not in *Escherichia coli* in individually housed broilers. J Antimicrob Chemother 52(4):719–723 doi:10.1093/jac/dkg402
- Haffjee IE, Moosa A (1985) Honey in the treatment of infantile gastroenteritis. Br Med J (Clin Res Ed) 290(6485):1866–1867
- Rolfé RD (2000) The role of probiotic cultures in the control of gastrointestinal health. J Nutr 130:396S–402S
- Molan PC (1992) The antibacterial activity of honey. I. The nature of the antibacterial activity. Bee World 73(1):5–28
- Adebolu TT (2005) Effect of natural honey on local isolates of diarrhea-causing bacteria in southwestern Nigeria. Afr J Biotechnol 4(10):1172–1174
- Molan PC (1992) The antibacterial activity of honey. II. Variation in the potency of the antibacterial activity. Bee World 73(2):59–76
- Allen KL, Molan PC, Reid GM (1991) A survey of the antibacterial activity of some New Zealand honeys. J Pharm Pharmacol 43(12):817–822
- Molan PC, Betts JA (2004) Clinical usage of honey as a wound dressing: an update. J Wound Care 13(9):353–356
- Shannon IL, Edmonds EJ, Madsen KO (1979) Honey: sugar content and cariogenicity. ASDC J Dent Child 46(1):29–33
- National Committee for Clinical Laboratory Standards (2002) Performance standards for antimicrobial disk and dilution susceptibility tests for bacteria isolated from animals: approved standard (M31-A2). NCCLS, Wayne, PA
- Silley P (2003) *Campylobacter* and fluoroquinolones: a bias data set? Environ Microbiol 5(4):219–230 doi:10.1046/j.1462-2920.2003.00425.x
- Bolton FJ, Coates D, Hutchinson DN (1984) The ability of *Campylobacter* media supplements to neutralize photochemically induced toxicity and hydrogen peroxide. J Appl Bacteriol 56(1):151–157
- Corry JEL, Post DE, Laisney MJ (1995) Culture media for the isolation of *Campylobacter*s. Int J Food Microbiol 26:43–76 doi:10.1016/0168-1605(95)00044-K
- Allen KL, Molan PC, Reid GM (1991) The variability of the antibacterial activity of honey. Apiacta XXVI:114–121
- George HA, Hoffman PS, Smibert RM, Krieg NR (1978) Improved media for growth and aerotolerance of *Campylobacter fetus*. J Clin Microbiol 8(1):36–41
- Gorman R, Adley CC (2004) An evaluation of five preservation techniques and conventional freezing temperatures of –20 degrees C and –85 degrees C for long-term preservation of *Campylobacter jejuni*. Lett Appl Microbiol 38:306–310 doi:10.1111/j.1472-765X.2004.01490.x
- Ribeiro CD, Marks J, Grimshaw AD (1985) Economic cultivation of “thermophilic” *Campylobacter* spp. J Clin Pathol 38(11):1311–1312 doi:10.1136/jcp.38.11.1311
- Wang G, Clark CG, Taylor TM, Pucknell C, Barton C, Price L et al (2002) Colony multiplex PCR assay for identification and differentiation of *Campylobacter jejuni*, *C. coli*, *C. lari*, *C. upsaliensis*, and *C. fetus* subsp. *fetus*. J Clin Microbiol 40(12):4744–4747 doi:10.1128/JCM.40.12.4744-4747.2002
- Jett BD, Hatter KL, Huycke MM, Gilmore MS (1997) Simplified agar plate method for quantifying viable bacteria. Biotechniques 23(4):648–650
- R Development Core Team (2007) R: a language and environment for statistical computing. R Foundation for Statistical Computing, Vienna
- Cooper RA, Halas E, Molan PC (2002) The efficacy of honey in inhibiting strains of *Pseudomonas aeruginosa* from infected burns. J Burn Care Rehabil 23(6):366–370 doi:10.1097/00004630-200211000-00002

34. Cooper RA, Molan PC, Harding KG (2002) The sensitivity to honey of Gram-positive cocci of clinical significance isolated from wounds. *J Appl Microbiol* 93:857–863 doi:10.1046/j.1365-2672.2002.01761.x
35. French VM, Cooper RA, Molan PC (2005) The antibacterial activity of honey against coagulase-negative staphylococci. *J Antimicrob Chemother* 56(1):228–231 doi:10.1093/jac/dki193
36. Natarajan S, Williamson D, Grey J, Harding KG, Cooper RA (2001) Healing of an MRSA-colonized, hydroxyurea-induced leg ulcer with honey. *J Dermatolog Treat* 12:33–36 doi:10.1080/095466301750163563
37. Al Somal N, Coley KE, Molan PC, Hancock BM (1994) Susceptibility of *Helicobacter pylori* to the antibacterial activity of manuka honey. *J R Soc Med* 87:9–12
38. Cooper RA, Molan PC, Harding KG (1999) Antibacterial activity of honey against strains of *Staphylococcus aureus* from infected wounds. *J R Soc Med* 92(6):283–285
39. Doyle MP, Roman DJ (1982) Response of *Campylobacter jejuni* to sodium chloride. *Appl Environ Microbiol* 43(3):561–565
40. Reezal A, McNeil B, Anderson JG (1998) Effect of low-osmolality nutrient media on growth and culturability of *Campylobacter* species. *Appl Environ Microbiol* 64(12):4643–4649
41. Cuccurullo SJ (2004) Physical medicine and rehabilitation board review. Demos Medical Publishing, New York
42. Adams CJ, Boulton CH, Deadman BJ, Farr JM, Grainger MN, Manley-Harris M et al (2008) Isolation by HPLC and characterisation of the bioactive fraction of New Zealand manuka (*Leptospermum scoparium*) honey. *Carbohydr Res* 343(4):651–659 doi:10.1016/j.carres.2007.12.011
43. Mavric E, Wittmann S, Barth G, Henle T (2008) Identification and quantification of methylglyoxal as the dominant antibacterial constituent of Manuka (*Leptospermum scoparium*) honeys from New Zealand. *Mol Nutr Food Res* 52(4):483–489 doi:10.1002/mnfr.200700282